

**BY ORDER OF THE COMMANDER
WRIGHT-PATTERSON AIR FORCE
BASE**

**WRIGHT-PATTERSON AIR FORCE
BASE INSTRUCTION 13-204**

14 SEPTEMBER 2022

***Nuclear, Space, Missile, Command, and
Control***

AIRFIELD OPERATIONS



COMPLIANCE WITH THIS PUBLICATION IS MANDATORY

ACCESSIBILITY: Publications and forms are available on the e-publishing website at www.e-publishing.af.mil for downloading or ordering.

RELEASABILITY: There are no releasability restrictions on this publication.

OPR: 88 OSS/OSA

Certified by: 88OSS/CC
(Lt Col Donald E. Roley)

Supersedes: WRIGHTPATTERSONAFBI 13-201,
25 June 2013

Pages: 94

This instruction implements AFPD13-2, *Air Traffic, Airfield, Airspace and Range Management*, AFMAN 13-204v1, *Management of Airfield Operations* and AFMAN 13-204V2, *Airfield Management*. AFMAN 13-204V3, *Air Traffic Control*. It describes procedures to be used for airfield operations at Wright-Patterson AFB, Ohio (WPAFB OH). It is a directive for all assigned, attached, or transient units and flight crews, but not intended to replace sound judgment in the interest of safety. Refer recommended changes and questions about this publication to the Office of Primary Responsibility (OPR) using the AF Form 847, *Recommendation for Change of Publication*; route AF Form 847s from the field through the appropriate functional's chain of command. Ensure that all records created as a result of processes prescribed in this publication are maintained in accordance with (IAW) Air Force Manual (AFMAN) 33-363, *Management of Records*, and disposed of IAW Air Force Records Information Management System (AFRIMS) Records Disposition Schedule (RDS).

SUMMARY OF CHANGES

This document has been substantially revised and must be completely reviewed. This revision corrected numerous content inconsistencies and reference errors throughout the document. Changes include, but are not limited to: Changes to HAZPADS and wartime contingency information,

updated airfield diagram, updated taxiway dimensions, revised bird watch conditions, aircraft reduced firefighting capabilities, hot refueling operations.

Chapter 1—GENERAL INFORMATION REGARDING AIRFIELD FACILITIES	7
1.1. Runways and Taxiways.	7
1.2. Parking Plan.	7
1.3. Permanently Closed Airfield Surfaces.	8
1.4. Unusable Airfield Surfaces.	10
1.5. Runway Selection Procedures.	10
1.6. Aircraft Arresting Systems (AAS) (see	10
1.7. Airfield Lighting Systems.	12
1.8. Control of Ground Traffic in the Controlled Movement Area (CMA):	13
1.9. Air Traffic Control (ATC)/Airfield Management Operations (AMOPS) Facilities and Airfield Services.	14
1.10. Local Frequencies/Channelization.	14
Table 1.1. Local Frequencies.	14
1.11. Automated Terminal Information Service (ATIS) Procedures.	14
1.12. Navigational Aids (NAVAIDs).	14
1.13. Auxiliary power for ATCALS Facilities.	15
1.14. Civil Use of Military ATCALS.	15
1.15. Procedures for Protecting Precision Approach Critical Areas.	15
1.16. Precision Obstacle Free Zone (POFZ) (See	16
1.17. Airfield Restrictions.	16
1.18. Restricted Areas on the Airfield (See Attachment 7).	17
1.19. Procedures for Suspending and Resuming Runway Operations.	17
1.20. Procedures for Opening and Closing the Runway.	17
1.21. Aircraft Special Operations Areas/Ramps.	17
1.22. Aircraft Towing Procedures.	18
1.23. Aircraft Taxiing Requirements/Routes.	18
1.24. Engine Test/Run-Up Procedures.	19
1.25. Noise Abatement Procedures.	20
1.26. Ramp Isolation (ISO) and Quiet Hour Procedures.	20
1.27. Human Remains Movement.	21
1.28. Aircraft Rescue and Fire Fighting Capabilities (ARFF).	21

Table 1.2.	USAF ARFF affected Vehicle Sets.	22
Table 1.3.	ARFF Definitions.	23
1.29.	Control Tower (Tower) Blind Spots.	24
1.30.	Conducting Runway Inspections/Checks.	24
1.31.	Runway Surface Condition (RSC)/Runway Condition Reading (RCR) Procedures.	25
1.32.	Airfield Snow Removal Operations.	26
1.33.	Airfield Maintenance/Construction.	28
1.34.	Digital Audio Legal Recorder (DALR). WPAFB utilizes the DALR system for recording communications IAW AFMAN 13-204V1.	29
1.35.	Unmanned Aircraft Systems (UAS).	29
1.36.	RAMS Club Operations at Wright Field.	29
Chapter 2—FLYING AREAS		31
2.1.	Local Flying Area/Designation of Airspace (See	31
2.2.	Visual Flight Rule (VFR) Local Training Area.	31
Chapter 3—VISUAL FLIGHT RULES (VFR) PROCEDURES		32
3.1.	VFR Weather Minimums.	32
3.2.	VFR Traffic Patterns (see	32
3.3.	Special Procedures.	32
3.4.	Tactical Arrival/Departure (TAD) Procedures.	33
3.5.	AFMC Standardized Reduced Same Runway Separation (RSRS).	33
3.6.	Intersection Departures.	33
Table 3.1.	Note: Runway Remaining for Intersection Takeoff.	33
Chapter 4—INSTRUMENT FLIGHT RULES (IFR) PROCEDURES		34
4.1.	Radar Traffic Patterns.	34
4.2.	Surveillance (ASR) and Precision Approach Radar (PAR) Approaches.	34
4.3.	Local Departure Procedures.	34
4.4.	Radar Vector to Initial Procedures.	34
Chapter 5—EMERGENCY PROCEDURES		35
5.1.	Operation of the Primary Crash Alarm System (PCAS) and Secondary Crash Net (SCN).	35
5.2.	Emergency Response Procedures.	36
5.3.	External Stores Jettison Area Procedures.	37

5.4.	Fuel Dumping.	38
5.5.	Emergency Aircraft Arresting System Procedures.	38
5.6.	Hot Brake Areas and Procedures (see.....)	39
5.7.	Abandonment of Aircraft (Controlled Bail-Out).	39
5.8.	Personnel Locator Beacon (PLB)/ Crash Position Indicator (CPI)/ Emergency Locator Transmitter (ELT) Response Procedures.	39
5.9.	Hung Ordnance/Jammed Gun/Hot Gun Procedures (See	39
5.10.	Hydrazine Response Procedures.....	40
5.11.	Wind Limitations on Patterson Tower.....	41
5.12.	Evacuation of Airfield Operations Facilities.	41
5.13.	Alternate Facility Procedures.....	42
5.14.	Earthquake Procedures.	43
5.15.	Preventing and Resisting Aircraft Piracy (Hijacking) Procedures.....	43
Chapter 6—OTHER EMERGENCY PROCEDURES AS LOCALLY DETERMINED (SIMULATED FLAME-OUT, PRECAUTIONARY APPROACHES)		44
6.1.	Simulated Flame-out (SFO) Approaches (Overhead and Straight-in).....	44
Chapter 7—FLIGHT PLANNING PROCEDURES		46
7.1.	Flight Planning Procedures.	46
Chapter 8—MISCELLANEOUS PROCEDURES		49
8.1.	Airfield Operations Board AOB Membership:.....	49
8.2.	AOB Mandatory Review Board Briefing Requirements.	49
Table 8.1.	AOB Annual Review Items.	50
8.3.	Notice to Air Missions (NOTAM) Procedures.	50
8.4.	FLIP Accounts, Procedures for Requesting Changes.	50
8.5.	Prior Permission Required (PPR) Procedures.....	50
8.6.	Air Evacuation Notification and Response Procedures.	50
8.7.	Unscheduled/Unauthorized Aircraft Arrivals.	51
8.8.	Distinguished Visitor (DV) Notification Procedures.....	51
8.9.	Dangerous/Hazardous Cargo. Refer to paragraph 1.18., Table 1.18., 1.18.1., 18.2., Airfield Restrictions.....	51
Table 8.2.	Authorized Parking Areas for Aircraft Carrying Explosives.....	52
Figure 8.1.	Hotel and India Row Explosives Safety Clear Zone.....	54
Figure 8.2.	West Ramp Explosives Safety Clear Zone.	54

8.10.	Night Vision Device (NVD) Operations.....	55
8.11.	Local Aircraft Priorities: Aircraft priorities set by 14 CFR, Aeronautics and Space, Part 91, FAA JO 7110.65, Air Traffic Control, and this instruction are:	55
8.12.	Aircraft Lost Communications Instructions.....	55
8.13.	Standard “Climb-Out” Instructions.....	55
8.14.	Opposite Direction Take-Offs and Landings.....	56
8.15.	Breakout/Go Around/Missed Approach Procedures.....	56
8.16.	Civilian Aircraft Operations.	56
8.17.	Gate 26A (Base Vehicle Inspection Gate) Operations.....	57
8.18.	Weather Dissemination and Coordination Procedures.	57
8.19.	Variable Winds.	58
8.20.	445 AW Aircraft Ground Operations Concept Operations (CONOPS).	58
8.21.	Explosive Ordnance Disposal (EOD) Range Procedures.	58
8.22.	Bird/Wildlife Control: Local Bird/Aircraft Strike Hazard (BASH) Program.....	61
8.23.	Bird Watch Conditions (BWC).....	61
8.24.	Supervisor of Flying (SOF) Operating in the Tower.	62
8.25.	Airfield Photography.	62
8.26.	Wear of Hats/PPE.	63
8.27.	Airfield Smoking Policy.	63
8.28.	Military Assumes Responsibility for Separation of Aircraft (MARSA) Procedures.....	63
8.29.	Customs, Agriculture, and Immigration.	63
8.30.	Aircraft Hurricane Evacuation (HUREVAC).	64
Chapter 9—INFORMATION DISPLAY SYSTEMS (IDS5) PROCEDURES		65
9.1.	IDS5 Network.	65
9.2.	IDS5 Security.....	65
9.3.	IDS5 User Responsibilities.....	65
Chapter 10—CONTROLLED AREA		66
10.1.	Airfield Controlled Area.....	66
Attachment 1—GLOSSARY OF REFERENCES AND SUPPORTING INFORMATION		68
Attachment 2—WRIGHT FIELD AIRFIELD DIAGRAM		79
Attachment 3—PATTERSON FIELD AIRFIELD DIAGRAM		80
Attachment 4—PATTERSON FIELD EAST RAMP PARKING PLAN		81

Attachment 5—PATTERSON FIELD WEST RAMP PARKING PLAN	82
Attachment 6—PATTERSON FIELD RUNWAY 05L/23R PRECISION OBSTACLE FREE ZONE (POFZ) AND LOCALIZER CRITICAL AREA	83
Attachment 7—PATTERSON FIELD CONTROLLED MOVEMENT AREA/ RESTRICTED AREA	85
Attachment 8—PATTERSON FIELD AIRFIELD SPECIAL OPERATIONS AREAS/RAMPS	86
Attachment 9—FLYING AREAS	87
Attachment 10—VFR TRAFFIC PATTERNS	88
Attachment 11—STRAIGHT IN SIMULATED FLAME-OUT (SI-SFO)	89
Attachment 12—OVERHEAD SIMULATED FLAME OUT (SFO)	90
Attachment 13—445 AW GROUND OPERATIONS	91
Attachment 14—PATTERSON DROP ZONE	92
Attachment 15—AIRFIELD SWEEPING PLAN	93
Attachment 16—RAMS CLUB FLYING FIELD – WRIGHT FIELD (AREA B)	94

Chapter 1

GENERAL INFORMATION REGARDING AIRFIELD FACILITIES

1.1. Runways and Taxiways.

1.1.1. The Wright-Patterson AFB airfield, hereafter referred to as “Patterson Field,” has two active parallel runways oriented northeast/southwest. Distance between runway centerlines is 1,325 ft. Field elevation is 823 ft MSL as measured at the approach end of RWY 23R (See [Attachment 3](#)).

1.1.1.1. RWY 05L/23R is a 12,600 ft long, 300 ft wide Class B precision runway with no shoulders and is grooved to USAF standards. It has a 900 ft overrun on the northeast end and 1,000 ft overrun on the southwest end. The first 2,600 ft of RWY 05L is concrete and is the only portion of the airfield where Vertical Takeoff and Landing (VTOL) aircraft operations are authorized. The remaining surface of RWY 05L/23R and all of RWY 05R/23L is asphalt.

1.1.1.2. RWY 05R/23L is a 7,000 ft long 150 ft wide Class A non-precision runway with no shoulders. It is a grooved runway with a 450 ft overrun on the southwest end. RWY 05R/23L may be closed during snow removal operations or heavy rainfall due to potential hydroplaning.

1.1.2. Patterson Field has seven taxiways designated Alpha, Alpha 1, Alpha 2, Bravo, Bravo 1, Charlie, and Delta (See [Attachment 3](#)).

1.1.2.1. TWY Alpha is 75 ft wide and runs parallel to RWY 05L/23R for the full length of the runway’s western edge. Pilots in Command (PIC) are cautioned not to mistake TWY Alpha for a runway.

1.1.2.2. TWY Alpha 1 is 75 ft wide and connects TWY Alpha with the northwest entrance to the West Ramp.

1.1.2.3. TWY Alpha 2 is 75 ft. wide and connects TWY Alpha with the southwest entrance to the West Ramp.

1.1.2.4. TWY Bravo is 75 ft wide, except for TWY Bravo between RWY 05L/23R and 05R/23L (non-standard 300 ft at widest point). TWY Bravo crosses the approach end of RWY 23L. PICs and vehicle operators are cautioned as this crossing point can be deceptive.

1.1.2.5. TWY Bravo 1 is 75 ft wide and connects TWY B to the East Ramp.

1.1.2.6. TWY Charlie is 75 ft wide and intersects TWY Alpha, RWY 05L/23R, RWY 05R/23L, and TWY Bravo.

1.1.2.7. TWY Delta is 75 ft wide and intersects TWY Alpha, RWY 05L/23R, RWY 05R/23L and TWY Bravo.

1.2. Parking Plan.

1.2.1. East Ramp Parking Plan (See [Attachment 4](#)).

1.2.1.1. Delta parking row standard configuration is sited for A-10 aircraft and smaller.

- 1.2.1.2. Echo parking row standard configuration is sited for A-10 aircraft and smaller.
- 1.2.1.3. Foxtrot parking row standard configuration is sited for C-172 aircraft and smaller.
- 1.2.1.4. Golf parking row standard configuration is sited for C-21 aircraft and smaller.
- 1.2.1.5. Hotel parking row standard configuration is sited for C-17 aircraft and smaller. Aircraft with a wingspan larger than 174 ft will require a non-standard parking plan configuration.
- 1.2.1.6. India parking row standard configuration is sited for C-5 aircraft and smaller.
- 1.2.1.7. November1 standard configuration is sited for B-747/200 aircraft and smaller and is an alert pad.
- 1.2.1.8. Hot Cargo Pads1-4 (See [Table 8.2](#)):
 - 1.2.1.8.1. Any aircraft with a tail height of 49 ft or greater will not park on Hot Cargo Pad 2, as that will violate the 50:1 ratio of the Approach/Departure Clearance Surface (ADCS) for RWY 05R/23L.

1.2.2. West Ramp Parking Plan (See [Attachment 5](#)):

- 1.2.2.1. Parking spots A1-A14 are sited for C-17 aircraft. (See [Table 8.2](#)).

1.2.3. All non-standard parking of aircraft must be prior coordinated and approved by the Airfield Manager (AFM) or designated representative.

1.3. Permanently Closed Airfield Surfaces.

1.3.1. Wright Field (KDWF). Wright Field is closed and arrangements must be coordinated to open it for one-time delivery of aircraft to the National Museum of the U.S. Air Force (NMUSAF) and operating procedures for aircraft balloons, blimps and special aerial events. The NMUSAF originates the request to open Wright Field to the approval authority, HQ AFMC A3/6 for aircraft delivery. (See [Attachment 2](#)).

1.3.2. NMUSAF Aerial Events and Aircraft Delivery Responsibilities

1.3.2.1. NMUSAF:

- 1.3.2.1.1. Assumes overall responsibility and liability for the safety and security of each operation, aircraft, and personnel involved, and is accountable for planning and executing this plan.
- 1.3.2.1.2. Submits and obtains all MAJCOM and FAA waivers/approvals as required meeting all time constraints.
- 1.3.2.1.3. Addresses other participants in each Operations Plan submitted to HQ AFMC A3/6.
- 1.3.2.1.4. Originates all requests for flying operations to the approving authority, HQ AFMC A3/6 through 88 OSS/OSA.
- 1.3.2.1.5. Identifies an “Event Coordinator” responsible for the planning, preparation and general management of each event. Coordination with 88 OSS, 88 ABW/SE, 88 CEG, 88 SFS, and 88 ABW/CEM will be accomplished as necessary.

1.3.2.1.6. Provides a concept of operations to 88 OSS/OSA at least 90 days prior to the scheduled event.

1.3.2.1.7. For aerial events, the NMUSAF will comply with requirements IAW AFI 10-1001 and forward required documentation to Airfield Management for processing.

1.3.2.2. Airfield Management:

1.3.2.2.1. Acts as an advisor to the Event Coordinator

1.3.2.2.2. The AFM, OSS Director of Special Operations, or designated representative shall determine if the runway or landing surface, approach/departure zones, or any obstructions/violations pose risks that must be repaired, mitigated, or waived. Identify any areas of concern prior to any takeoff/landing of aircraft. The PIC must accept final responsibility.

1.3.2.2.3. Processes required documentation from the PIC IAW AFI 10-1001 with the Event Coordinator as required.

1.3.2.2.4. Meets with the PIC and 88 ABW/SE at the earliest possible time to discuss procedures, limiting factors, and safe handling requirements.

1.3.3. NMUSAF Aircraft Delivery Procedures.

1.3.3.1. Landings are made on RWY 09 only (elevation 830' MSL).

1.3.3.2. The operation is conducted during VFR/daylight hours and with runway surface condition (RSC) DRY.

1.3.3.3. The length of RWY 09 (7147 x 150 ft) must be adequate to allow a safe landing for the type of aircraft concerned (runway is marked with yellow X's spaced about 1,000 ft apart along its length and may be used by the PIC as a rough guide for runway distance remaining). RWY 09 runway surface is asphalt. RWY 09 runway markings are IAW UFC 3-260-04 for a closed runway.

1.3.3.4. The Base Weather Station (WX) will supply a portable anemometer to provide wind information for relay to the aircraft. Winds must be within safe limits for the type of aircraft concerned (as determined by the PIC).

1.3.3.5. AFM, OSS Director of Special Operations, or designated representative will:

1.3.3.5.1. Notify the Fire Department (FD) at least one working day in advance for fire/crash emergency vehicle standby at Wright Field.

1.3.3.5.2. Notify Security Forces (SFS) as soon as requirements are known but at least one working day in advance for crowd and vehicle control at Wright-Field.

1.3.3.5.3. Coordinate with Patterson Tower at least one business day in advance.

1.3.3.5.4. Coordinate with the Wing Safety Office (SE) and Public Affairs (PA).

1.3.3.5.5. Determine if foreign object debris (FOD) sweeping is required on RWY 09 prior to a landing and, if so, will coordinate with Base Civil Engineering (CE) to accomplish sweeping operations.

1.3.3.5.6. Brief the PIC on the following:

1.3.3.5.6.1. Traffic pattern direction (left-hand at Wright Field).

1.3.3.5.6.2. Traffic pattern altitude (same as Patterson Field for type of aircraft concerned).

1.3.3.5.7. Coordinate with Air Force Research Lab (AFRL), Bldg 622, DSN 785-6361, before a landing is made at Wright Field to de-conflict any possible laser activity encompassing RWY 09.

1.3.3.5.8. Be on-scene to inspect the runway before the landing, provide landing advisories to the arrival aircraft and exercise overall supervision.

1.3.3.6. Radio frequency for communication between aircraft and AMOPS vehicle use 88 ABW discrete UHF 289.4/VHF 123.225, if possible.

1.3.3.7. The aircraft normally lands at Patterson Field (KFFO) prior to USAF Museum delivery so the PIC may be taken to Wright Field for a visual inspection of RWY 09, with any hazards and obstructions specifically pointed out. If this is impractical, a visit by the aircrew to WPAFB prior to the delivery flight for a pre-site survey and/or a detailed visual presentation (i.e. video, PowerPoint, etc.) by the AFM or other authorized designated official of Wright Field's runway is required.

1.3.3.8. Flights originating at Patterson Field for a landing at Wright Field requires the PIC to file a flight plan with Patterson Field Airfield Management (AM).

1.3.3.9. USAF Museum point of contact is the Special Events Division (255-8046), NMUSAF/MUS.

1.4. Unusable Airfield Surfaces.

1.4.1. South arm/de-arm located on TWY B is unusable due to insufficient pavement distance requirements for parking. The alternate location is Hot Cargo Pad 4.

1.5. Runway Selection Procedures.

1.5.1. RWYs 23L/R are designated the calm wind runways.

1.5.2. Tower Watch Supervisor (WS) shall coordinate with Columbus (CMH) Approach prior to changing the runway in use. Tower WS is the final authority for runway selection.

1.5.3. Tower shall update the Airfield Automation System (IDS5) and notify the following agencies when a RWY change is complete:

1.5.3.1. CMH.

1.5.3.2. Airfield Management Operations (AMOPS).

1.5.3.3. WX.

1.5.3.4. FD.

1.6. Aircraft Arresting Systems (AAS) (see [Attachment 3](#)).

1.6.1. Patterson Field has two installed AAS: BAK-12(B)/TYPE H located 1,676 ft from the approach end of RWY 05L and BAK-12(B)/14 located 1,740 ft from the approach end of RWY 23R. Both AAS cables are bi-directional and primarily operated by Tower.

1.6.2. There are two “Barrier Shacks” on either side of RWY 05L/23R in line with each AAS (4 total) and are not equipped with evacuation bailout alarms.

1.6.3. The AAS cables are maintained in the down position unless requested by PIC or as required.

1.6.4. Barrier Maintenance (88 CEOFP) is responsible for daily AAS operating inspections, maintenance, and repair during normal duty hours (weekdays, between the hours of 0730L and 1600L). Results of all AAS daily checks will be reported to AMOPS to ensure NOTAM action is taken in the event of outages or status change. Barrier Maintenance must re-certify the AAS after each engagement regardless of date/time.

1.6.4.1. FD assumes responsibility for AAS outside normal duty hours to include holidays, weekends, and during non-availability of Barrier Maintenance personnel.

1.6.5. AMOPS will post AAS status on the IDS5. AMOPS will also perform visual checks of the AAS when Tower reports a suspected malfunction.

1.6.6. AAS Engagement:

1.6.6.1. Engagement of any AAS by an aircraft shall be treated as an emergency except for those instances of planned engagements for system tests and/or certifications. (See [paragraph 5.5](#)).

1.6.7. AAS Certification Procedures (must be accomplished annually):

1.6.7.1. AMOPS will be on-site to coordinate operations between aircraft, Tower, Barrier Maintenance, FD and any other required responders. AMOPS will also ensure aircraft tug and tow bar are in place. AMOPS shall solicit aircraft’s landing weight and speed of engagement from the PIC and relay information to Incident Commander (IC). If possible, AMOPS will establish contact with aircraft on 88 ABW discreet frequency UHF 289.4/VHF 123.225. If unable, AMOPS will request Tower to relay data to aircraft.

1.6.7.2. When aircraft is capable of taxiing, tail hook can be raised and if the arresting gear cable is clear of the hook, with concurrence from the IC and PIC, AMOPS will request the aircraft to taxi clear of the runway.

1.6.7.3. If the arresting system cable won't release from the tail hook, a slingshot procedure may be attempted. Clear the area fore and aft of the aircraft and ask the PIC to accelerate ahead slightly for a short distance using engine thrust, allowing the cable to reach its maximum run out distance and then reducing engine thrust to idle (aircraft brakes are not applied). The aircraft is gently pulled backward by a natural "slingshot" action of the cable, and the tail hook should "coast" clear of the cable. Slingshot procedures during in-flight emergencies that require rapid removal of an aircraft from a cable do not require approval from the ABW/CC, but PIC approval is required. For planned engagements and/or certifications, ABW/CC and PIC approval is required.

1.6.7.4. If aircraft engines are shut down, the tail hook cannot be raised for any reason, or the cable cannot be freed from the hook, then the aircraft must be towed.

1.6.7.5. If aircraft engines are not shut down, Transient Alert (TA) will pin landing gear as required when cleared by the IC. If cable is free of the tail hook and the hook can be raised, with IC and PIC concurrence, use a "follow-me" truck and have PIC taxi aircraft to the parking ramp.

1.6.7.6. When the aircraft is clear of the runway, AMOPS will inspect for FOD, ensure Barrier Maintenance inspects and resets the arresting system, and reopen the runway as soon as possible.

1.6.7.7. The AFM will maintain a record of arresting gear engagements to include date, time, aircraft type, tail number, speed and weight at engagement, arresting system used, distance the AAS tape traveled, and determine if aircraft is left/right or on runway centerline (RCL).

1.6.7.8. TA responsibilities:

1.6.7.8.1. Respond with tug, tow bar, landing gear pins and other tools and equipment as required.

1.7. Airfield Lighting Systems.

1.7.1. RWY 05L/23R:

1.7.1.1. High Intensity Runway Lights (HIRL).

1.7.1.2. Runway Distance Markers (RDM).

1.7.1.3. Runway Guard Lights (RGL), also known as wig-wags, are located at TWY Alpha/RWY 23R VFR hold line, TWY Alpha INST hold line, TWY Charlie/RWY 23L VFR Hold Line on the East side, and TWY Bravo/RWY 23L VFR hold line and are tied in with the runway edge lights.

1.7.1.4. Arresting Gear Markers (AGM). AAS cable locations are indicated by 40-inch diameter yellow disks (arresting gear markers) on each side of the runway which are internally illuminated for night time use.

1.7.1.5. Approach Lighting System with Sequence Flashing Lights (ALSF-1).

1.7.1.6. Precision Approach Path Indicator (PAPI).

1.7.1.6.1. RWY 23R PAPIs are non-standard as they are positioned on the right side of RWY 23R.

1.7.1.6.2. PAPIs are at a 3 degree angle coincidental to Instrument Landing System (ILS).

1.7.2. RWY 05R/23L.

1.7.2.1. Medium Intensity Runway Lights (MIRL). These lights are preset to the highest step for MIRLs and are not adjustable.

1.7.2.2. RDMs.

1.7.2.3. PAPIs.

1.7.2.3.1. PAPIs are at a 3 degree angle coincidental to ILS. **NOTE: No ILS approach to RWY 05R/23L.**

1.7.3. Patterson Field is also equipped with a rotating beacon, and security lighting for the East Ramp, West Ramp, and parking spot N-1.

1.7.4. In the event Tower is unmanned, control of the airfield lighting is transferred to AMOPS or to the lighting vault, as appropriate. In the event of an emergency landing, AMOPS will ensure all of the necessary changes are made to the airfield lighting settings IAW FAA JO 7110.65, *Air Traffic Control*, Chapter 3 Section 4.

1.7.5. A daily check (Monday through Friday) of the airfield lighting system to include the APCH lights, north of Highway 235 (off base), shall be accomplished by Airfield Lighting (LEX). Results of the check including lighting system reliability and outages shall be reported to AMOPS upon completion.

1.7.6. AMOPS will accomplish an airfield lighting serviceability check IAW AFMAN 13-204V2, *Airfield Management*, Chapter 5, and OSAM OI 13-201, *Airfield Management*. AMOPS will process an emergency work task if an outage significantly affects flying operations.

1.8. Control of Ground Traffic in the Controlled Movement Area (CMA):

1.8.1. Patterson Airfield's CMA is defined as runways, overruns and any area within 100 ft of these areas (See [Attachment 7](#)). All aircraft, vehicles and pedestrians must contact, receive authorization from and maintain two-way radio contact with Tower prior to entry and while in the CMA. Vehicle operators and pedestrians must also notify Tower immediately upon exiting the CMA.

1.8.2. Lost Communications.

1.8.2.1. In the event of lost communications, Tower will control aircraft, vehicle and pedestrian traffic by light gun signals and/or flashing the runway edge lights on and off to alert vehicle operators/pedestrians to exit the runway immediately. If use of light gun signals and/or flashing lights is unsuccessful, Tower will contact AMOPS to have the vehicle/pedestrian traffic escorted a safe distance from the CMA.

1.8.2.2. Vehicle operators/pedestrians will exit the CMA immediately upon knowledge of lost communications, identification of light gun signals or flashing of runway edge lights and contact Tower or AMOPS immediately to advise off the CMA and include any pertinent information that might affect safe runway operations. If not able to communicate with Tower or AMOPS via radio, use other means of communication such as a cellular phone (when available) to call the tower watch supervisor at 937-257-7199 or AMOPS at 937-257-4492.

1.8.2.3. Vehicle operators/pedestrians will report all lost communication incidents to AMOPS.

1.8.3. Refer to WPAFBI13-213, *Airfield Driving* for all airfield vehicular/pedestrian traffic requirements and communication procedures to include examples of proper radio phraseology and a listing of standard vehicular call signs.

1.9. Air Traffic Control (ATC)/Airfield Management Operations (AMOPS) Facilities and Airfield Services.

1.9.1. Patterson Tower and AMOPS are operational 24 hours daily unless otherwise specified by NOTAM or in the IFR Supplement.

1.9.2. TA is a contracted agency, reference U.S. IFR Supplement for hours of operation and contact information. Services are available during non-operational hours with a one hour prior coordination to AMOPS with TA approval.

1.9.3. Fleet Service is available with a 3 hour prior notification to AMOPS. Payment is required by AIRCARD or cash.

1.10. Local Frequencies/Channelization.

Table 1.1. Local Frequencies.

Agency	VHF	UHF	
Local Control	126.9	281.45	UHF Backup-253.5
Ground Control	121.8	335.8	
ATIS	124.475	269.9	
Pilot to Dispatch	126.2	372.2	
Pilot to METRO	N/A	348.4	
Columbus APCH/DEPT	118.85	269.275	
445 AW Command Post		349.4	
88 ABW Special Events	123.225	289.4	
<i>NOTE: The 88 ABW Special Events frequencies are for special events/contingencies and are available from 88 OSS Special Operations Director on request.</i>			

1.11. Automated Terminal Information Service (ATIS) Procedures.

1.11.1. ATIS Frequencies:

1.11.1.1. VHF 124.475.

1.11.1.2. UHF 269.9.

1.11.2. ATIS normally broadcasts from 0700L – 2200L, daily, unless otherwise required for mission requirements.

1.11.3. PICs shall use ATIS to the maximum extent possible.

1.11.4. Tower will notify AMOPS of any ATIS outages.

1.12. Navigational Aids (NAVAIDs).

1.12.1. Tower is designated as the primary NAVAID monitor facility. Tower is responsible for notifying AMOPS of all outages to ensure the proper submission of required NOTAMs

1.12.2. TACAN.

1.12.2.1. Class: Terminal.

1.12.2.2. Identification: FFO.

1.12.2.3. Frequency: Channel 99.

1.12.2.4. DME: Available on 115.2.

1.12.2.5. Location: On Patterson Field.

1.12.2.6. Restrictions: TACAN unusable between the 250 and 360 degree radials beyond 6NM below 5,000 ft MSL.

1.12.2.7. Checkpoint:

1.12.2.7.1. TACAN Radial and DME: FFO 154/0.3 located on Hot Cargo Pad 1.

1.12.3. ILS RWY 23R:

1.12.3.1. Identification: I-FFO.

1.12.3.2. Frequency: 109.7 MHz.

1.12.4. ILS RWY 05L:

1.12.4.1. Identification: I-FAE.

1.12.4.2. Frequency: 109.7 MHz.

1.12.5. Preventative Maintenance Inspections (PMIs) are normally scheduled to occur annually by the CONUS Regional Maintenance Center (RMC), Oklahoma City.

1.12.6. ATCALs facilities are not equipped with evacuation bailout alarms.

1.13. Auxiliary power for ATCALs Facilities.

1.13.1. All NAVAIDs are equipped with reliable auto-start auxiliary generators.

1.14. Civil Use of Military ATCALs.

1.14.1. Transient civil aircraft may use Patterson Airfield NAVAIDs for practice approach/training purposes although limited to low approaches only. These aircraft are handled as routine traffic and approved on a noninterference basis.

1.15. Procedures for Protecting Precision Approach Critical Areas.

1.15.1. There are two Glide Slope (GS) critical areas. One is on TWY Alpha (north end) and the other is on TWY Bravo (south end) marked with instrument hold lines and internally lighted signs.

1.15.2. There are two Localizer critical areas: One includes the overrun on the approach end of RWY 23R and the other is off the departure end of RWY 23R. These are rectangular areas that extend from the localizer transmitting antenna 2,000 ft toward the approach end of the RWY and 150 ft on each side of the RWY centerline. They include a 50 ft wide extension behind each localizer antenna (See [Attachment 3](#)).

1.15.3. Unless specific approval is obtained from Tower, aircraft and vehicles will hold short of the instrument (INST) hold lines/signs whenever any of the following conditions exists:

1.15.3.1. Advised to "HOLD SHORT OF ILS CRITICAL AREA" by Tower.

1.15.3.2. The reported ceiling is below 800 ft and/or the reported visibility is less than 2 miles.

1.15.3.2.1. Tower will visually verify sterilization of any vehicles operating in the active ILS/GS critical area. All vehicles operating on the TWY must monitor the Tower NET (LMR) IAW WPAFBI 13-213. When Tower is unable to visually check or contact vehicles via two-way radio, AMOPS will be contacted to physically check the area.

1.15.3.2.2. When it has been determined that ILS critical areas shall be protected, Tower and AMOPS will make a broadcast announcement over both the BASE OPS and TOWER NETs (LMR) stating: "ILS CRITICAL AREAS ARE PROTECTED". AMOPS will also inform personnel reporting entry onto the airfield, as applicable.

1.15.4. If in doubt, the vehicle operator will contact Tower for permission to enter any critical area.

1.15.5. Two-way radio contact must be maintained with Tower while operating in the ILS/GS critical area when any of the conditions in [paragraph 1.16.3](#) exist.

1.16. Precision Obstacle Free Zone (POFZ) (See [Attachment 6](#)).

1.16.1. The POFZ is an 800 ft wide by 200 ft long rectangular area centered on the RWY centerline, beginning at and extending outward from the threshold, designed to protect aircraft flying precision approaches from ground vehicles and other aircraft when the ceiling is less than 300 ft, or visibility is less than three-quarter (3/4) statute mile (or Runway Visual Range (RVR) below 4,000 ft).

1.16.2. Exception: vehicles less than 10 ft in height operating outside of the movement area and necessary for the maintenance of the airport and/or navigation facilities are allowed to traverse the POFZ. These vehicles will maintain radio contact with Tower when allowed to park in these areas. There are no normal vehicle operations in the POFZ except for mowers.

1.16.3. Prior to access into the POFZ, all personnel will be briefed by AMOPS.

1.16.4. Vehicles over 10 ft in height must remain outside of the POFZ during inclement weather. Vehicle operators must contact Tower to determine if the ceiling and visibility will restrict operations.

1.17. Airfield Restrictions.

1.17.1. Tower will ensure no personnel are working within the CMA of RWY 05R/23L when 133 ft or larger wingspan aircraft are utilizing RWY 05R/23L.

1.17.2. Engine-Running Offload/On-load (ERO) or Engine-Running Crew Change (ERCC) in front of building 206 and hangar 206 north/south involving aircraft with wingspans greater than 131 ft require AFM approval.

1.17.3. For guidelines on parking an aircraft loaded with explosive materials and armament, see section 8.9.2.

1.18. Restricted Areas on the Airfield (See Attachment 7).

1.18.1. Restricted areas on Patterson Field are delineated by a red painted line on the surface of the pavement or with use of rope and stanchions. Access is through an established entry control point (ECP) marked with a sign or a break in the rope. Restricted areas are secured IAW AFI 31-101, *Integrated Defense (FOUO)*, operators entering restricted areas must be authorized and have the appropriate area designated on their AF Form 1199, *Air Force Entry Control Card (Accountable) (Used with Advanced Automated Entry Control System)*, or listed on an approved Entry Authorization List (EAL).

1.18.1.1. The West Ramp is a permanent Protection Level PL 3 restricted area.

1.18.1.2. E-4B parking area located on the East Ramp is a PL 1 restricted area 30 minutes prior to arrival and 30 minutes upon departure.

1.18.1.3. Delta row 1-6, all Hot Cargo Pads and Hotel row 3-4 are considered restricted areas only when aircraft are parked in these locations.

1.18.1.3.1. Transient aircraft that require establishment of a temporary restricted area outside of these designated areas will be defined by the use of rope and stanchions unless otherwise coordinated by the AFM for FOD and safety concerns.

1.19. Procedures for Suspending and Resuming Runway Operations.

1.19.1. AFM, Tower WS, or designated representative appointed by the 88 OSS/CC may suspend runway operations when any unsafe condition affects runway operations IAW AFMAN 13-204V2. AFM/Tower WS will inform the other when runway operations are suspended.

1.19.2. Runway operations are automatically suspended immediately following the arrival of an emergency aircraft.

1.19.3. AFM or designated representative will perform a runway check prior to resuming operations. AFM or designated rep is the sole authority for resuming runway operations.

1.20. Procedures for Opening and Closing the Runway.

1.20.1. AFM or designated representative shall temporarily close the runway when any unsafe condition affects runway operations IAW AFMAN 13-204V2, Chapter 6, and complete local checklists/QRCs, as required.

1.20.2. Runway or airfield closures must be approved by the AFM.

1.20.3. AFM or designated representative shall perform a runway inspection prior to opening the runway and resuming normal runway operations.

1.21. Aircraft Special Operations Areas/Ramps.

1.21.1. Arm/De-Arm Areas (See [Attachment 8](#)).

1.21.1.1. Aircraft shall arm and de-arm their weapons in one of the following designated areas:

1.21.1.1.1. North end of TWY Bravo between RWY 23R APCH end and RWY 23L APCH end. Armed aircraft shall be parked headed in a southwesterly direction.

1.21.1.1.1. All non-associated aircraft and vehicular operations shall be suspended on TWY Bravo between RWY 23R APCH end and RWY 23L APCH end while arm/de-arm area is in use.

1.21.1.1.2. Hot Cargo Pad 4. Armed aircraft shall be parked headed in a southwesterly direction.

1.21.1.1.2.1. When arm/de-arm area on Hot Cargo Pad 4 is in use, all non-associated aircraft and vehicular operations shall be suspended on TWY Bravo south of Hot Cargo Pad 4.

1.21.1.1.2.2. Hot Cargo Pad 3 shall not be used for concurrent munitions handling if there are aircraft being armed/de-armed on Hot Cargo Pad 4.

1.21.2. Aircraft Drag Chute Procedures:

1.21.2.1. Drag chutes are jettisoned into the grass area after exiting RWY 05L/23R at TWY Alpha or Bravo and before taxiing across RWY 05R/23L.

1.21.2.2. The PIC will notify Tower when aircraft chute is deployed.

1.21.2.3. TA will retrieve all transient aircraft chutes.

1.21.3. Hot Refueling Operations:

1.21.3.1. The designated parking spots authorized for hot refueling the NAOC E-4B aircraft (including pit refueling) are N-1, India Row and Hot Cargo Pad 3. FD is required to be on-site during hot refueling and hot liquid oxygen operations.

1.22. Aircraft Towing Procedures.

1.22.1. All aircraft tows will be coordinated and approved by AMOPS. AMOPS will coordinate all aircraft movement with Tower via IDS5 or landline.

1.22.2. All aircraft tows and related movements will receive permission to commence towing operation from Tower and maintain radio (LMR/Frequency) contact until tow is complete. Tower will be notified when the towing operation is complete.

1.22.3. Exception: 445th Maintenance Group tow operations involving 445th Airlift Wing aircraft that will remain on the West ramp only require AMOPS approval and Tower coordination is not needed.

1.23. Aircraft Taxiing Requirements/Routes.

1.23.1. Tower approval is required prior to aircraft engine start and/or taxi operations.

1.23.1.1. Contact will be made with Ground Control (GC) concerning the nature of the request and the aircraft location. The aircrew is required to follow progressive taxi instructions provided by GC and monitor the GC frequency until Tower provides direction to switch frequencies.

1.23.1.2. When arriving/departing the ramp, the PIC will follow the marshaller's direction.

1.23.1.3. Engine RPM above idle is only used when necessary.

1.23.2. Prior to aircraft movement all fire extinguisher bottles and aircraft ground equipment (AGE) must be greater than 10 ft from edge of wingtip.

1.24. Engine Test/Run-Up Procedures.

1.24.1. Engine Run-Up Areas:

1.24.1.1. TWYs adjacent to the RWYs are used to check aircraft engines and associated equipment before departure.

1.24.1.2. West Ramp.

1.24.1.3. Warm-up pad adjacent to TWY Alpha 1.

1.24.1.4. Trim Pad.

1.24.1.5. Hotel Row (idle engine runs only).

1.24.1.6. Parking spot N-1.

1.24.2. Engine Test/Run-Up Procedures:

1.24.2.1. All aircraft will coordinate and gain approval from AMOPS prior to requesting engine run clearance from Tower. The requestor shall coordinate with AMOPS the type (high forward thrust, high reverse thrust, or low powered engine run), parking spot and the estimated engine run time.

1.24.2.1.1. Base/Tenant flying units will utilize their Maintenance Operations Center (MOC) to coordinate engine runs.

1.24.2.1.2. Transient aircrews will coordinate engine runs through TA.

1.24.2.2. Engine runs:

1.24.2.2.1. Will be conducted between the hours of 0600L-2200L, Mon-Sat and 1200L-2200L, Sundays and federal holidays. The 88 ABW/CC is the final approval authority for all engine runs exceeding these criteria. **NOTE:** *445 AW aircraft located on West Ramp are authorized idle engine runs 24/7. Anything above idle outside of the hours stated above will require 88 ABW/CC approval.*

1.24.2.2.2. Only mission essential requests will be approved outside of the above published hours.

1.24.2.3. Air traffic to RWY 05L/23R shall have priority over engine runs. **NOTE:** *National Airborne Operations Center (NAOC) E-4B aircraft are exempt from these procedures.*

1.24.2.4. AMOPS will inform Tower of approved engine run requests and all pertinent information via IDS5 or landline.

1.24.2.5. Continuous radio contact (LMR/Frequencies) must be maintained between the aircraft and Tower during engine runs. Tower will suspend high power engine runs as needed for aircraft movement. Aircraft will notify Tower when the engine run is complete.

1.24.2.6. The East Ramp “trim pad” is certified for A-10 aircraft and smaller engine runs.

1.24.2.6.1. The trim pad is located adjacent to TWY Bravo, south of TWY Charlie.

1.24.2.6.2. Turbojet engine run operations involving the afterburners must use the trim pad and will be pre-approved by the AFM or designated representative. If the aircraft

is too large to use the trim pad, coordinate with AMOPS for an approved alternate engine run up area.

1.24.2.7. The West Ramp is certified for high power engine runs.

1.24.2.8. High power engine runs are defined as any run above idle.

1.24.2.9. High power engine runs warrant the following:

1.24.2.9.1. Tower shall approve or delay forward thrust high power engine runs based on traffic pattern activity.

1.24.2.9.2. Tower will suspend high power engine runs on the West Ramp when aircraft operations on RWY 05L/23R are in progress. Aircraft engaged in an engine run shall be at idle power prior to:

1.24.2.9.2.1. Departing aircraft starting takeoff roll.

1.24.2.9.2.2. Arriving aircraft reaching a point that is 6 flying miles from the runway threshold.

1.24.2.10. C-17 aircraft low power engine runs are defined as at idle.

1.24.2.11. Tower GC will broadcast a blanket advisory for all West Ramp engine runs on the Tower NET/Tower frequencies.

1.24.2.12. In non-designated engine run areas, power settings shall not exceed idle RPM plus 15 percent for turbojet aircraft or 1,500 propeller RPMs for turboprop or reciprocating engine aircraft.

1.25. Noise Abatement Procedures.

1.25.1. To decrease aircraft noise in the surrounding communities, the following restrictions apply to all training flights:

1.25.1.1. 0100L – 0600L – Only initial departures on outbound flight plans (no VFR/IFR pattern entry)/full-stop landings are permitted.

1.25.1.2. 2300L – 0100L – All training flights must be held to the absolute minimum necessary for mission requirements.

1.26. Ramp Isolation (ISO) and Quiet Hour Procedures.

1.26.1. Ramp ISO is defined as the act of isolating a portion of the airfield for non-essential aircraft, vehicles and personnel for all General Officers/Civilian equivalent, DV code 3 or above. The AFMC Commander is exempt unless traveling with a person of equal or higher rank.

1.26.1.1. Ramp ISO requests (i.e. airfield location, dates, times, etc.) will be coordinated and approved through AFM or designated representative.

1.26.2. Quiet hours are defined as the act of curtailment of noise producing activity in a designated area for special outdoor events. Operation of aircraft engines or AGE will be held to an absolute minimum and must be prior approved by the AFM or designated representative.

1.26.3. Ramp Isolation/Quiet Hours Procedures:

1.26.3.1. Ramp Isolation.

1.26.3.1.1. Ramp ISO will encompass the area between the north and south ECP of Bldg. 206 and TWY Bravo from TWY Bravo1 to TWY Charlie.

1.26.3.1.2. AMOPS will inform Tower, TA, transient aircrew, 445 CP, SFS, Fuels, Fire Department, NAOC (if on station), RAWs, and AFM. When informing Tower, AMOPS will pass aircraft call sign for whom ramp ISO will be established. Upon Termination of Ramp ISO, AMOPS will notify the same agencies.

1.26.3.1.3. AMOPS and TWR will make a blanket announcement on the Base Ops/Tower NETs respectively when Ramp ISO initiated and again upon termination.

1.26.3.1.4. Tower will direct all aircraft not in direct support of the event to remain clear of the ramp isolation area.

1.26.3.1.5. SFS will report to the airfield 15 minutes prior to the activation of ramp ISO to prevent all non-essential vehicles/pedestrians from accessing the affected ramp at applicable airfield gates, and/or surrounding areas. SFS will not impede aircraft operations or the detail in support of the event.

1.26.3.2. Quiet Hours.

1.26.3.2.1. Quiet Hours will encompass the entire airfield, anything different will be included in the published NOTAM. 88 OSS/CC is the approval authority for Quiet Hours and changes to the area in which the Quiet Hours will include.

1.26.3.2.2. AMOPS will publish a NOTAM and notify TWR, TA, Fuels, Fire Department, NAOC (if on station), Transient Aircrews, 445th CP, AMOM, DAFM, AFM and all contractors and or additional agencies working on or around the airfield that could be effected by the restriction.

1.26.3.2.3. AMOPS and TWR will make a blanket announcement on the LMR NET stating “Quiet Hours in effect until (time)” and “Quiet Hours Terminated”.

1.27. Human Remains Movement.

1.27.1. Human remains movements will be conducted IAW the AMOPS Human Remains checklist.

1.28. Aircraft Rescue and Fire Fighting Capabilities (ARFF).

1.28.1. In the event the FD’s ability to provide aircraft fire coverage increases or decreases, due to the availability of firefighting assets, FD will provide AMOPS with ARFF vehicle and aircraft category set status. These procedures are IAW Technical Implementation Guide 403-18, Mar 2018.

1.28.1.1. Category/Status Definitions:

1.28.1.1.1. Black (Wright-Patt specific color). The emergency response capability (ERC) for a critical level of service (CLS) is unavailable. The property involved in the fire is expected to be destroyed.

1.28.1.1.2. Red. Fire fighting forces cannot be expected to be successful in interior aircraft fire suppression/rescue operations. Fire fighting forces can perform only limited exterior fire suppression. Aircrew must exit under their own power; rescue of trapped personnel should not be expected.

1.28.1.1.3. Yellow. Interior/exterior aircraft/rescue or fire suppression capability is severely limited. Fire fighting forces can still be expected to fight and control exterior fires in such a manner as to maintain a rescue path for one minute. Aircrew must exit under their own power; attempted rescue of trapped personnel severely endangers rescuers.

1.28.1.1.4. Green. Reasonable expectation fire fighting forces will be successful at interior/exterior aircraft fire suppression and rescue of aircrew.

Table 1.2. USAF ARFF affected Vehicle Sets.

USAF ARFF Vehicle Set (IAW Technical Implementation Guide 403-18 and local guidance).	
USAF ARFF Vehicle Set	Examples of USAF Aircraft (IAW AFPAM 32-2004)
6	C-5A/B, 787-8i
5	VC-25, MD-11, B-747, KC-10
4	NAOC E-4B (waivered), B-1, B-2, B-52, C-17,, KC/EC-135, B-727, KC-46
3	C-9, C-22, C-32, C-37, C-40, C-130, E-3, E-8, MH-53, RC-135, T-43
2	C-20
1	A-10, BQM-34, C-12, C-21, CV-22, C-38, F-15, F-16, F-22, F-35, HH60, MQM-107, QF-4, RQ-1A/B, RQ-4 T-1, T-37, T-38, T-6, UH-1, UV18, and U-2
<p><i>NOTE: Vehicle and aircraft sets are matched to illustrate the FD's capability of supporting select aircraft operations dependent upon available firefighting assets. Wright-Patterson FD is adequately equipped/staffed for aircraft category/sets 1-4 and only reports these capabilities.</i></p>	

Table 1.3. ARFF Definitions.

Optimum Level of Service (OLS)	100 to 90% (Green). The level of service where all authorized resources are available for emergency response within response time standards. OLS provides sufficient capability for quick response and sustained operations after arrival on scene. During OLS, emergency response forces shall accomplish all objectives when responding to emergency incidents.
Reduced Level of Service (RLS)	89 to 70%, (Yellow). The level of service when ERC is less than OLS but greater than CLS. Sufficient capability is provided for initial response, scene assessment and implementation of mitigation tactics. This level of service represents increased risk/loss potential due to lack of ERC to perform rescue and sufficient mitigation tactics simultaneously. FES objectives may not be successful during situation where simultaneous rescue and firefighting activities are required
Critical Level of Service (CLS)	69 to 60% (Red). A CLS capability exists when 7 firefighters are available to respond to an emergency within the response time standards. Aircraft emergencies must meet established response time criteria for announced and unannounced emergencies. Upon arrival, the Incident Commander will determine the appropriate action to be taken depending upon their initial evaluation of the situation. Successful outcomes can only be expected when the incident can be quickly mitigated. Firefighters are expected to revert to defensive operations when the emergency cannot be quickly contained.
Inadequate Level of Service (ILS)	<60% (Black). ILS is when the ERC for a CLS is unavailable. The property involved in the fire is expected to be destroyed.

1.28.1.2. AMOPS will complete ARFF checklist as appropriate.

1.28.1.3. When ARFF capabilities have been downgraded to “red” due to real world events, operations on the airfield for the affected category/set will cease until operations are approved by the 88 ABW/CC with the exception of Set 6 aircraft, see [paragraph 1.28.1.5](#) The 445 AW assigned aircraft operations are approved by 445 OG/CC with 88 ABW/CC concurrence. Depending on the severity of the ARFF status, additional suspensions of all maintenance, fueling, and other activity may be required for affected aircraft. The 88 OSS/DO will coordinate with 445 OG/CC for 445 AW operations. The 788 CES/CC, in coordination with the 88 OSS/DO, will coordinate with the 88 ABW/CC for any aircraft operations curtailment. AMOPS is responsible for coordination with the 88 OSS/DO and issuing an appropriate NOTAMS as required ensuring the flying community is informed of the restriction(s). Any set in “the red” affects all of the sets above it, see [Table 1.3](#).

1.28.1.3.1. ARFF Red Status Actions:

1.28.1.3.1.1. AMOPS will contact Tower to suspend all local transition (training) flights for affected aircraft.

1.28.1.3.1.2. Tower will hold all takeoffs and landings for affected aircraft in the immediate vicinity pending approval from appropriate authority.

1.28.1.4. When ARFF capabilities have been downgraded to "black" for set 4 aircraft all operations in that set will cease. Aircraft operations associated with AMC or TACC missions will follow guidance found in AMCI 11-208. When set 5 and 6 aircraft are assessed as "black" the 788 CES in coordination with 88 OSS will request approval for aircraft operations. Operations will be limited to one takeoff and one landing as necessary for the mission.

1.28.1.5. When ARFF capability is "green" for Set 4 aircraft no actions are required to approve Set 5 and above aircraft operations at WPAFB. When ARFF level for Set 4 aircraft falls below OLS follow paragraph [1.28.1.3](#) or [1.28.1.4](#).

1.29. Control Tower (Tower) Blind Spots.

1.29.1. Visual Blind Spots (See [Attachment 3](#)):

1.29.1.1. Southern Corner of the East Ramp.

1.29.1.2. Between Hangar 206 North and Hangar 206 South on East Ramp.

1.29.1.3. East Ramp between all hangars/buildings.

1.29.1.4. Foxtrot 5-8.

1.29.1.5. Golf Row on East Ramp.

1.29.1.6. Hotel Row on East Ramp (only during camera outages).

1.29.2. Radio Blind Spots:

1.29.2.1. Hotel parking spot one, intermittent LMR use only.

1.29.2.2. Between Hangar 206 North and Hangar 206 South on East Ramp, intermittent LMR use only.

1.30. Conducting Runway Inspections/Checks.

1.30.1. AFM or designated representative will perform an airfield inspection IAW AFMAN 13-204V2.

1.30.2. When priority access is requested by AMOPS, airfield inspections/checks will have precedence over aircraft operations.

1.30.3. AMOPS will perform airfield checks IAW AFMAN 13-204V2, in support of the following:

1.30.3.1. In-Flight Emergencies (IFE).

1.30.3.2. Ground Emergencies (GE).

1.30.3.3. Runway Surface Condition (RSC)/Runway Condition Reading (RCR).

1.30.3.4. FOD.

- 1.30.3.5. Bird Air Strike Hazard (BASH)/Wildlife habitat control, ponding, etc.
 - 1.30.3.5.1. Any report of bird activity or wildlife on, near, or around the airfield.
 - 1.30.3.5.2. Upon change of active runway, a bird activity check will be conducted on the arrival/departure end for airborne, standing, roosting, or grazing birds.
- 1.30.3.6. Airfield lighting and marking retro-reflectivity check.
- 1.30.3.7. Uncommon airfield events, such as unauthorized landing, severe weather, snow/ice removal operations, cessation of construction activities for the day, etc.
- 1.30.3.8. Wide Body/Heavy Aircraft. Check must be accomplished after arrival/departures on RWY 05L/23R and RWY 05R/23L prior to fighter-type aircraft arrival/departure or other aircraft which may be more susceptible to FOD damage.
- 1.30.3.9. Coordinate with CE to ensure vegetation growth on or adjacent to the airfield (i.e., grass mowing, tree/brush trimming, etc.) is maintained IAW AFI 91-202, AFI 91-212 and WPAFB BASH/Wildlife Hazard Reduction Plan. These areas include but are not limited to overruns, drainage, culverts/ditches, perimeter fencing, approach surfaces and areas around airfield lighting.
- 1.30.3.10. In support of Night Vision Device (NVD) operations.

1.31. Runway Surface Condition (RSC)/Runway Condition Reading (RCR) Procedures.

- 1.31.1. RSC will be determined and reported IAW AFMAN 13-204V2, Chapter 7.
 - 1.31.1.1. AMOPS will:
 - 1.31.1.1.1. Conduct a physical check of the runway to determine RSC Dry.
 - 1.31.1.1.1.1. A periodic check is required to monitor current RSC and ponding conditions on the airfield. Exception: RSC check will be delayed when there is a Weather Warning for Lightning within 5 NM.
 - 1.31.1.1.2. Advise Tower of current RSC.
 - 1.31.1.1.3. Process NOTAM when surface is other than dry.
 - 1.31.1.1.4. Update IDS5.
 - 1.31.1.1.5. Annotate all actions on the AF Form 3616.
 - 1.31.2. RCR Procedures. WPAFB receives significant amounts of snow fall, freezing precipitation, and icing each year. AMOPS personnel utilize the RT3 Roadway Friction Tester or Bowmonk AFM2 to determine and report Air Force standard RCR IAW AFMAN 13-204V2, Chapter 7, Technical Order (T.O) 33-1-23, *Equipment and Procedures for Obtaining Runway Condition Readings*, Flight Information Handbook (FIH), Bowmonk AFM2 and RT3 Instructions and local checklists/QRCs.
 - 1.31.2.1. AMOPS will:
 - 1.31.2.1.1. Conduct RCR checks.
 - 1.31.2.1.1.1. During changing conditions (e.g. temperature changes, snow fall, icing, and treatment of airfield surfaces), RCR checks must be completed every 2 hours or as mission dictates (from time of last completed check).

1.31.2.1.1.2. When RSC is reported as Wet Runway (WR) or Slush on Runway (SLR) and the possibility for freezing conditions exist, conduct RCR checks no less than every 2 hours or as often as mission dictates.

1.31.2.1.1.3. When the RCR is 12 or less, accomplish RCR checks as frequently as normal flying operations allow. During periods of slow activity, conduct RCR checks before each aircraft arrival/departure.

1.31.2.1.2. Report/Record RCR value to the following:

1.31.2.1.2.1. Tower.

1.31.2.1.2.2. E-4B Watch Officer (if on station).

1.31.2.1.2.3. 445 CP.

1.31.2.1.2.4. Tenant and transient flying units.

1.31.2.1.2.5. Update IDS5.

1.31.2.1.2.6. Process a Local/Safety NOTAM as applicable to report RSC/RCR and other information essential to safe operations (e.g. depth and location of precipitation).

1.31.2.1.3. When chemicals are applied to airfield surfaces:

1.31.2.1.3.1. Notify Tower, TA, 445 MOCC, 445 CP, and transient aircrews.

1.31.2.1.3.2. Process a Safety NOTAM.

1.31.2.1.3.3. Annotate all actions on AF Form 3616.

1.31.2.1.3.4. Work with Snow Operations Crew Leader (“Snow 1”) to determine when chemicals dissipate or are “washed away” to cancel NOTAM.

1.32. Airfield Snow Removal Operations.

1.32.1. General. Snow and ice can delay operational capability and present hazardous ground operating conditions for aircraft. *WPAFB Snow and Ice Control (S&IC) Plan* governs airfield snow and ice removal as well as anti-icing operations. Snow removal is normally operational from November through April, and operates 24/7 as required.

1.32.2. The *WPAFB S&IC Plan* outlines three priority areas: Priority 1, Priority 2, and Priority 3. The AFM or designated representative may amend priority surfaces to ensure safe handling of mission essential airfield/aircraft operations.

1.32.3. Responsibilities below are in addition to those in *WPAFB S&IC Plan*:

1.32.3.1. The Chief, S&IC, or a representative, is the Snow Operations Crew Leader (“Snow 1”) and will conduct airfield snow and ice removal according to the *WPAFB S&IC Plan*, current airfield operational needs, existing weather conditions, and available equipment.

1.32.3.2. Snow 1 shall:

1.32.3.2.1. Maintain close coordination with AMOPS regarding S&IC removal priorities, activities and progress to include notification of airfield entry and exit.

- 1.32.3.2.2. Maintain two-way radio communication at all times with Tower and all snow removal vehicles.
- 1.32.3.2.3. Report to Tower when all snow removal vehicles are off the runway.
- 1.32.3.2.4. Brief vehicle operators on runway entering/exiting procedures.
- 1.32.3.2.5. Notify Tower and AMOPS when:
 - 1.32.3.2.5.1. Snow 1 changes (due to shift change, etc.)
 - 1.32.3.2.5.2. Snow 1 is off the airfield and has another vehicle assume crew lead responsibilities
 - 1.32.3.2.5.3. Snow 1 changes vehicles
- 1.32.3.2.6. Advise Tower and AMOPS when snow removal operations are suspended/terminated.
- 1.32.3.3. Snow Removal Vehicle Operators will:
 - 1.32.3.3.1. Monitor the Control Tower NET (LMR) for essential information relating to the runway.
 - 1.32.3.3.2. In case of radio failure, vehicle operators shall inform the Snow 1 immediately. Snow 1 will coordinate with Tower for removal of the vehicle from the CMA and taxiways until radio communication can be reestablished with Tower.
 - 1.32.3.3.3. Check in with AMOPS upon entering and exiting the airfield.
- 1.32.3.4. Tower will:
 - 1.32.3.4.1. Turn on all airfield lighting when snow removal operations are in progress.
 - 1.32.3.4.2. Request CMH Approach provide a 15 mile from landing advisory on all Patterson Field arriving aircraft, and in turn, relay this promptly to Snow 1.
 - 1.32.3.4.3. Advise the Snow 1 of all departing aircraft prior to taxi.
- 1.32.3.5. AFM or designated representative will:
 - 1.32.3.5.1. Monitor airfield surfaces for snow/ice buildup during winter weather conditions. During changing weather conditions conduct more frequent airfield checks to ensure airfield is mission capable at all times.
 - 1.32.3.5.1.1. As a general rule, begin snow or ice removal operations when airfield markings become obscured or at the onset of icing conditions; begin anti-icing operations when ground temperatures and precipitation conditions warrant. Contact CE Snow Desk or CE Service Call Desk.
 - 1.32.3.5.1.2. Conduct airfield inspections/checks as snow or ice conditions require. Ensure snow removal activities do not create wind rows that interfere with aircraft operations on runways, taxiways, and aircraft parking aprons that violate airfield/airspace criteria. AMOPS personnel shall monitor airfield surfaces to ensure buildup of snow or ice does not exceed a height of 24 inches or creates wingtip clearance hazards.

1.32.3.5.1.3. Taxiways/aprons will be closed when pavement markings are completely covered, when the RCR Value is 5 or below (NIL braking action condition), or at the discretion of the AFM or designated representative.

1.32.3.5.1.4. Coordinate with base/tenant flying units concerning any interruption of flying operations necessitated by airfield snow and ice removal activity. Request base/tenant flying units to terminate training flights, if required. AMOPS will evaluate requests by base/tenant flying units for airfield snow removal and will notify the Snow 1 of any priority changes.

1.32.3.5.2. Conduct RCR and RSC checks, as necessary.

1.32.3.5.3. Relay the current RSC and/or RCR data to Tower and AMOPS to include, restricted/suspended/closed taxiways, runways, and/or aircraft parking aprons, and location of windrows at or above 24 inches in height or that are creating wingtip clearance hazards.

1.32.4. Closing of RWY 05R/23L during snow removal operations:

1.32.4.1. When airfield snow removal is in progress and RWY 05R/23L is closed, snow removal vehicles may cross RWY 05R/23L without Tower authorization provided the following is accomplished:

1.32.4.1.1. Snow 1 coordinates with AMOPS to confirm the closure of RWY 05R/23L.

1.32.4.1.2. Snow 1 contacts the Tower to confirm that RWY 05R/23L is closed and advises Tower that vehicles will be crossing the closed RWY 05R/23L to conduct snow removal operations.

1.33. Airfield Maintenance/Construction.

1.33.1. All airfield maintenance/construction will be pre-coordinated with the AFM IAW AFMAN 13-204V2.

1.33.2. AMOPS will:

1.33.2.1. Brief Tower prior to the start of all maintenance/construction on the airfield that will restrict flight/ground movement and/or pose a safety hazard to aircraft operations.

1.33.2.2. Close/suspend/restrict affected airfield surfaces as appropriate and issue applicable NOTAM(s).

1.33.2.3. Conduct and document construction checks as required per AFMAN 13-204V2 and OSAM OI 13-201.

1.33.3. Maintenance/Construction personnel will:

1.33.3.1. Adhere to all airfield requirements outlined in WPAFBI13-213.

1.33.3.2. Notify AMOPS upon airfield entry/exit.

1.33.4. Airfield Sweeping Plan.

1.33.4.1. Airfield Sweeper will report on the airfield by 0830L on Mon - Fri. The schedule for the week is as follows (See [Attachment 15](#) for visual diagram):

1.33.4.1.1. Monday – 05L/23R, TWY B between the runways, approach end TWY A abeam 23R, TWY C from 23R to TWY A.

1.33.4.1.2. Tuesday – West Ramp, TWY A1, TWY A2, TWY A from TWY A1 to TWY C.

1.33.4.1.3. Wednesday – East Ramp, TWY C from TWY B to 23L, TWY B from Air Freight Terminal to 23L.

1.33.4.1.4. Thursday – TWY B from TWY C to approach end 05L, all Hot Cargo Pads, TWY D from TWY B to 23L, TWY B1, aircraft trim pad.

1.33.4.1.5. Friday – 05R/23L, TWY D from 23L to TWY A, TWY A from TWY C to approach end 05L. **EXCEPTION:** Sweeping operations falling on a federal holiday will be conducted the duty day before or after and will be coordinated with AMOPS.

1.33.4.1.6. Once a month or as needed – Airfield access roads.

1.33.5. AFM or designated representative will coordinate with sweeper regarding any additional requirements after the daily airfield inspection/checks have been completed. Daily sweeper schedule is subject to change based on mission requirements.

1.33.6. If a sweeper is needed after hours or weekends, AMOPS will notify CE Help Desk. Upon notification, Airfield CE personnel have up to one hour to respond.

1.33.7. Airfield Mowing Operations.

1.33.7.1. Mower operators will report on and off the airfield at the beginning and end of mowing activity and prior to leaving for lunch and upon returning. Airfield Mowers normally operate from April – November, Monday-Friday from 0700L – 1630L

1.33.7.2. Areas around the taxiways and runways will be mowed to a height of 7 to 14 inches.

1.33.7.3. Mowers will minimize driving on or crossing runways or taxiways due to FOD concerns. In the event the equipment produces FOD on a taxiway or runway, mowers will contact AMOPS immediately and advise them of the location.

1.34. Digital Audio Legal Recorder (DALR). WPAFB utilizes the DALR system for recording communications IAW AFMAN 13-204V1.

1.34.1. Tower will provide the following:

1.34.1.1. Daily recording quality checks.

1.34.2. Tower will notify AMOPS and RAWS if any AMOPS/Tower frequencies or landlines are not recording.

1.34.3. Tower will provide AM Staff access to recordings upon request.

1.35. Unmanned Aircraft Systems (UAS).

1.35.1. Small Unmanned Aerial Systems (sUAS) operations are conducted IAW *Wright-Patterson AFB sUAS Policy Letter*.

1.36. RAMS Club Operations at Wright Field.

1.36.1. Concept of Operations

1.36.2. RAMS club is a recreational organization that operates small remote controlled aircraft under recreational guidance published by the FAA in circular 91-57 and the Academy of Model Aeronautics (AMA). RAMS club operates in the confines of Wright Field illustrated in the attachment. RAMS club flying activities will only take place 1700L-sunset on Weekdays and during daylight hours on holidays/weekends.

1.36.3. Responsibilities

1.36.3.1. RAMS club members will contact Wright Patterson AMOPS at 937-257-4492, 30 minutes prior to conducting any flying activities. RAMS club members will advise AMOPS when terminating prior to sunset. Additionally, RAMS club members will notify AMOPS of any aircraft mishaps on the runway if there is damage to the pavement.

1.36.3.2. AMOPS will notify Tower when RAMS Club is active.

1.36.3.3. WPAFB Tower will advise manned aircraft in the vicinity that recreational flying activity is occurring below 400' AGL over Wright Field.

Chapter 2

FLYING AREAS

2.1. Local Flying Area/Designation of Airspace (See [Attachment 9](#)).

2.1.1. The Patterson Class D is defined as that airspace extending upward from the surface and including 3,400 feet MSL within a 4.6-mile radius of Wright-Patterson AFB, and within 1.3 miles each side of the Patterson TACAN 046° radial extending from the 4.6-mile radius to 5.6 miles northeast of the TACAN, excluding that airspace within the James M. Cox Dayton International Airport (KDAY), OH, Class C airspace area.

2.1.2. KFFO is bordered to the northwest by KDAY Class C airspace.

2.2. Visual Flight Rule (VFR) Local Training Area.

2.2.1. Buckeye and Brushcreek Military Operations Areas (MOAs)/Air Traffic Control Assigned Airspace (ATCAA). Procedures for scheduling and hours of operations are listed in the Flight Information Publication (FLIP) AP 1/A and AP1/B.

Chapter 3

VISUAL FLIGHT RULES (VFR) PROCEDURES

3.1. VFR Weather Minimums.

3.1.1. The reported ceiling shall be at least 500 ft above the requested pattern altitude and the visibility at least 3 miles in order to operate in the VFR patterns (Exception: SVFR).

3.1.2. Tower may close any, or all, of the VFR patterns at the discretion of the Tower WS/Senior Controller (SC) if controllers are not able to keep aircraft in sight, regardless of reported weather.

3.2. VFR Traffic Patterns (see [Attachment 10](#)).

3.2.1. VFR Patterns are normally flown right traffic to right runways and left traffic to left runways at the following altitudes:

3.2.1.1. Rectangular.

3.2.1.1.1. Fighter/tactical/trainer aircraft: 2,400 ft MSL.

3.2.1.1.2. Other turbojet/turboprop aircraft: 1,900 ft MSL.

3.2.2. Overhead: 2,400 ft MSL.

3.2.2.1. Overhead Protection.

3.2.2.1.1. Tower shall amend “Climb-out” for departing aircraft to “MAINTAIN AT OR BELOW 1,900 UNTIL DEPARTURE END” when the overhead pattern is in use.

3.3. Special Procedures.

3.3.1. Aircraft Arresting System (AAS) Operations.

3.3.1.1. Departures. The departure end cable will be raised by Tower prior to tailhook equipped aircraft departing RWY 05L/23R, unless otherwise requested by the PIC. Tower controller shall verbally relay the status of the cable to the aircraft upon issuing takeoff clearance.

3.3.1.2. Arrivals. The departure end cable will be raised by Tower prior to tailhook equipped aircraft making an approach to RWY 05L/23R, unless otherwise requested by the PIC. Tower controller will verbally relay the status of the cable to the aircraft upon establishing communication.

3.3.1.3. System Integrity. The BAK-14 and the Type H hook cable support systems were not designed to operate in the up position with repeated aircraft rollovers. Repeated high-speed rollovers will damage the system components, reduce system reliability, increase the chance of a missed engagement, and increase maintenance costs.

3.3.1.3.1. Low-speed taxi rollovers must also be kept to a minimum to prevent degradation of system performance. If the AAS is not required to stop the aircraft, Tower should lower the BAK-14 or Type H prior to rollover.

3.3.2. Helicopter Operations.

3.3.2.1. Arrival/departure operations to/from any surface designated as an operational runway or taxiway is authorized. Arrival/departure to/from any portion of the parking apron is not authorized, unless prior coordinated with AM Staff.

3.3.3. Paradrop/Parajump Operations.

3.3.3.1. Paradrops are not authorized unless coordinated with AMOPS, Tower, and appropriate FAA agencies.

3.3.3.2. See [Attachment 14](#) for depiction of Patterson Drop Zone.

3.3.4. Functional Check Flights (FCFs).

3.3.4.1. FCFs are not normally conducted. Prior coordination is required.

3.4. Tactical Arrival/Departure (TAD) Procedures.

3.4.1. TAD maneuvers are conducted IAW TAD *Letter of Agreement* with the 445 AW and Columbus ATCT. TAD procedures are only authorized by units designated in the TAD *Letter of Agreement*.

3.5. AFMC Standardized Reduced Same Runway Separation (RSRS).

3.5.1. Patterson Tower utilizes AFMC RSRS IAW AFMAN 13-204V3.

3.6. Intersection Departures.

3.6.1. Intersection Departures are authorized IAW procedures outlined in FAAO JO 7110.65, *Air Traffic Control*.

3.6.2. PICs are responsible for determining if sufficient runway length is available to permit a safe departure, and may use the entire runway or a different intersection if they advise the Tower of their intentions and receive an appropriate ATC clearance. See [Attachment 3](#) for runway remaining (in feet) distances.

3.6.3. RWY 23R at TWY Bravo is the standard departure point for all aircraft taxiing from the East ramp. Controllers are not required to issue the ft remaining to any aircraft departing from this departure point unless requested by the PIC.

Table 3.1. Note: Runway Remaining for Intersection Takeoff.

RWY 23L	RWY 23R	RWY 05L	RWY 05R
TWY C 3,400ft	TWY B (north end) 11,600 ft	TWY D 8,400 ft	TWY D 6,700ft
TWY D NOT AUTHORIZED	TWY C 7,100ft	TWY C 5,400 ft	TWY C 3,600ft
	TWY D 4,100ft	TWY B (north end) NOT AUTHORIZED	

Chapter 4

INSTRUMENT FLIGHT RULES (IFR) PROCEDURES

4.1. Radar Traffic Patterns.

- 4.1.1. CMH Approach controls the radar traffic pattern.
- 4.1.2. The pattern is normally flown southeast of Patterson Field at 3,000 ft MSL.

4.2. Surveillance (ASR) and Precision Approach Radar (PAR) Approaches.

- 4.2.1. ASR and PAR approaches are not available at Patterson Field.

4.3. Local Departure Procedures.

- 4.3.1. Patterson Field has non-standard IFR take-off minimums and departure procedures published in the Terminal FLIP's.
- 4.3.2. Standard "Climb-out" for IFR departures is "FLY RUNWAY HEADING, MAINTAIN 3,000."
- 4.3.3. Aircraft in the VFR pattern requesting to enter the radar pattern shall coordinate with Tower one pattern prior to entering the radar pattern. Tower shall coordinate a "Climb-out" clearance with CMH Approach and issue the following short range IFR clearance to the aircraft prior to radio transfer:
 - 4.3.3.1. "CLEARED TO WRIGHT-PATTERSON AIR FORCE BASE VIA RADAR VECTORS ON DEPARTURE FLY RUNWAY HEADING (OR ALTERNATE INSTRUCTIONS) CLIMB AND MAINTAIN 3,000, SQUAWK (IF NEEDED)."
- 4.3.4. Tower shall amend "Climb-out" for departing aircraft to "MAINTAIN AT OR BELOW 1,900 UNTIL DEPARTURE END" when the overhead pattern is in use.

4.4. Radar Vector to Initial Procedures.

- 4.4.1. CMH Approach provides vectors to initial upon pilot request.

Chapter 5

EMERGENCY PROCEDURES

5.1. Operation of the Primary Crash Alarm System (PCAS) and Secondary Crash Net (SCN).

5.1.1. The PCAS and SCN will be maintained and utilized in accordance with AFMAN 13-204V2, paragraph 4.2.2.3 and AFMAN 13-204V3, paragraph 5.5.

5.1.2. The PCAS/SCN may be activated as requested by the EOC Director to support WPAFB CEMP 10-2 outlined in AFI 10-2501. The WPAFB CEMP 10-2 provides comprehensive guidance for emergency response to physical threats resulting from major accidents, natural disasters, conventional attacks, terrorist attack, and CBRN attacks.

5.1.3. Both systems will be checked daily between 0830L-0845L.

5.1.4. PCAS:

5.1.4.1. The following agencies are on the PCAS:

5.1.4.1.1. Tower.

5.1.4.1.2. AMOPS.

5.1.4.1.3. WPAFB Medical Center Emergency Room.

5.1.4.1.4. Flight Surgeon. Will only answer during normal duty hours (0700L - 1600L, Monday-Friday, excluding holidays).

5.1.4.1.5. Fire Station 1.

5.1.4.1.6. Fire Station 2 (receive only).

5.1.5. Tower will:

5.1.5.1. Activate the PCAS when, but not limited to:

5.1.5.1.1. Notified by the PIC, the agency responsible for the aircraft, or another ATC agency that an aircraft is experiencing an emergency.

5.1.5.1.2. Abnormal activity is seen on the aerodrome.

5.1.5.1.3. AAS engagement is expected or has occurred.

5.1.5.1.4. No radio (NORDO) aircraft is arriving.

5.1.5.1.5. Inbound aircraft intends to jettison external stores.

5.1.5.1.6. Fuel leak or hydrazine incident.

5.1.5.1.7. Unauthorized aircraft landing/movement.

5.1.5.1.8. Tower evacuation.

5.1.5.1.9. As necessary to update previously passed information.

5.1.5.2. PCAS Outage Procedures:

- 5.1.5.2.1. Tower will contact AMOPS via AMOPS DL, BASE OPS NET (LMR), or landline and inform AMOPS that the SCN must be activated. Pass all pertinent information to AMOPS.
- 5.1.5.2.2. Tower will contact the Flight Surgeon via landline, DSN 787-4285, and provide pertinent information that would have been passed via the PCAS.
- 5.1.6. SCN:
 - 5.1.6.1. AMOPS will activate the SCN to relay information received from Tower or other reliable sources that is critical to the safety and security of airfield/flight operations. Information received will be relayed verbatim.
 - 5.1.6.2. AMOPS will activate the SCN when requested by Tower when the PCAS cannot be utilized. All information received will be relayed verbatim.
 - 5.1.6.3. FD will activate the “All Call” when the SCN cannot be utilized, or as needed.

5.2. Emergency Response Procedures.

- 5.2.1. Emergency response vehicles shall stage as directed by IC, and IAW WPAFBI 13-213.
- 5.2.2. Emergency vehicles, Fire/Crash Recovery, Medical, AM, SE, and SFS responding to an aircraft emergency have priority over normal vehicular traffic.
- 5.2.3. Emergency vehicles will not enter the CMA without approval from Tower.
- 5.2.4. Tower will transmit on Tower Net and Crash/Fire NET (CFR1) when emergency aircraft is next to land: “EMERGENCY AIRCRAFT NEXT TO LAND.”
- 5.2.5. Once the aircraft has landed, runway operations are immediately suspended.
- 5.2.6. To facilitate the fastest possible response time of emergency response vehicles, Tower shall anticipate emergency response vehicle movement on the airfield after activation of the PCAS and/or SCN. Upon arrival of the IFE aircraft, GC may announce over the radio, using the Tower NET (CFR1), unsolicited emergency response vehicle authorizations to enter the RWY. Example:
 - 5.2.6.1. “ALL EMERGENCY RESPONSE VEHICLES AT *(location)* PROCEED ON *(active runway)*.” **NOTE:** *These actions DO NOT relieve emergency response vehicle operators from obtaining Tower approval to enter the active RWY if the Tower fails to automatically provide unsolicited blanket approvals.*
- 5.2.7. If feasible, communications between the IC and incident aircraft will be established utilizing frequency 123.225 or 289.4. The Ground Control frequency will not be used by the IC at any point.
- 5.2.8. The IC (Incident Commander) is responsible for advising Tower when all emergency response vehicles have exited the RWY.
- 5.2.9. Designation and responsibilities of the IC are outlined in the WPAFB Integrated Defense Plan (IDP), WPAFB CEMP 10-2, *WPAFB Preventing and Resisting Aircraft Piracy (Hijacking) Plan*, and OSAM OI 13-201.

5.2.10. All personnel will ensure information and names of personnel allegedly involved in an aircraft incident/accident are not released to any agency outside of the official chain of command without 88 ABW Public Affairs approval.

5.2.11. On Base Emergency Procedures.

5.2.11.1. Tower will:

5.2.11.1.1. Activate PCAS.

5.2.11.1.2. Complete all actions IAW locally developed checklists.

5.2.11.2. AM will:

5.2.11.2.1. Activate SCN, pass information verbatim from PCAS.

5.2.11.2.2. Complete all actions IAW locally developed checklists.

5.2.11.2.3. Respond appropriately to all airfield emergencies unless specifically stated in this operating instruction.

5.2.12. Off Base Emergency Procedures.

5.2.12.1. Tower will:

5.2.12.1.1. Activate PCAS.

5.2.12.1.2. Complete all actions IAW locally developed checklists.

5.2.12.2. AM will:

5.2.12.2.1. Activate SCN, pass information verbatim from PCAS.

5.2.12.2.2. Complete all actions IAW locally developed checklists.

5.3. External Stores Jettison Area Procedures.

5.3.1. External Stores Jettison Area:

5.3.1.1. The infield between RWY 05L/23R and TWY Alpha, southwest of TWY Delta (see [Attachment 8](#)). This area is used when external stores can be jettisoned while the PIC keeps visual contact with the ground.

5.3.1.2. If the drop is at night, Tower defines TWY Delta for the PIC by turning out all taxiway lights west of RWY 23R except TWY Alpha and TWY Delta.

5.3.1.3. Tower and AMOPS will not be responsible for the jettison of external stores.

5.3.2. External Stores Jettison Procedures:

5.3.2.1. PIC:

5.3.2.1.1. Flies an IFR approach to RWY 23R, descending not lower than IFR approach minimums or safe stores separation altitude, whichever is higher, until the runway is visually acquired and then positions the aircraft between the RWY and TWY Alpha.

5.3.2.1.2. Keeps a safe separation altitude above the ground for the type stores involved while maintaining visual contact with the airfield.

5.3.2.1.3. Maintains aircraft release speed as specified in the current aircraft-operating manual.

5.3.2.1.4. Ensures all stores jettisoned/released are dropped “SAFE.”

5.3.2.1.5. Jettisons/releases the stores upon passing TWY Delta (the drop point).

5.3.2.1.6. If the drop cannot be made, starts a right turn upon reaching the departure end of RWY 23R to enter closed traffic, avoiding populated areas and positions aircraft for a straight-in approach.

5.3.3. When notified of an impending jettison/release.

5.3.3.1. Tower will:

5.3.3.1.1. Activate the PCAS.

5.3.3.1.2. Broadcast a blanketed advisory over Tower NET, “ALL VEHICLES WEST OF RWY 05L/23R, EXIT THE AIRFIELD.”

5.3.3.2. AMOPS will:

5.3.3.2.1. Activate the SCN.

5.3.3.2.2. Broadcast a blanketed advisory over BASE OPS NET “ALL VEHICLES WEST OF RWY 05L/23R, EXIT THE AIRFIELD.”

5.3.3.2.3. If adequate time is available, AMOPS will ensure the drop area is free of personnel and equipment.

5.3.3.2.4. Respond and conduct an airfield check.

5.4. Fuel Dumping.

5.4.1. Fuel dumping will be handled IAW FAAO JO 7110.65, *Air Traffic Control*. Facilities concerned shall broadcast an advisory on appropriate radio frequencies at 3-minute intervals until the dumping stops.

5.5. Emergency Aircraft Arresting System Procedures.

5.5.1. Tower will activate the PCAS for all unplanned engagements and automatically suspend runway operations upon engagement. AMOPS is the only authority to resume runway operations.

5.5.1.1. AMOPS personnel responding to the airfield will:

5.5.1.1.1. Key up frequency UHF 289.4/VHF 123.225 and monitor frequency.

5.5.1.1.2. Position the AMOPS vehicle to observe the engagement and ensure Fire/Crash personnel and aircraft tug and tow bar are standing by.

5.5.1.1.3. Request Transient Alert (TA) to send a tug and tow bar and give the location as needed.

5.5.1.1.4. Ensure Barrier Maintenance is called to inspect, re-rig and recertify the arresting gear.

- 5.5.1.1.5. Maintain a record of arresting gear engagements to include date, time, aircraft type, tail number, speed and weight at engagement, arresting system used, distance the AAS tape traveled, and determine if aircraft is left/right or on runway centerline (RCL).
- 5.5.2. After an AAS engagement, the average delay to re-rig and recertify an AAS is 20-25 minutes. The IC advises Tower if this time will be exceeded.
- 5.5.3. After Barrier Maintenance recertifies the AAS, AM will conduct an airfield check and resume RWY operations.

5.6. Hot Brake Areas and Procedures (see [Attachment 8](#)).

- 5.6.1. The primary hot brake areas are the north and south ends of TWY Alpha, TWY Bravo between RWY 05R/23L and RWY 05L/23R, or the south end of TWY Bravo.
- 5.6.2. Aircraft with hot brakes should be kept clear of other aircraft, equipment, and personnel.

5.7. Abandonment of Aircraft (Controlled Bail-Out).

- 5.7.1. Prior to bailout, PICs should notify an ATC facility of intentions.
- 5.7.2. Controlled Bail-Out Areas:
 - 5.7.2.1. Primary: FFO 145 Radial, 45 NM fix.
 - 5.7.2.2. Alternate: CVG 077 Radial, 63 NM fix.
- 5.7.3. Upon request of the IC or if bailout is in an area other than the designated bailout area, FFO Tower will plot coordinates based on information obtained from CMH Approach and/or other sources and pass this information to emergency response personnel via PCAS.

5.8. Personnel Locator Beacon (PLB)/ Crash Position Indicator (CPI)/ Emergency Locator Transmitter (ELT) Response Procedures.

- 5.8.1. Tower will notify the following agencies upon receipt of an unscheduled emergency locator transmitter, personal locator beacon or crash position indicator signal:
 - 5.8.1.1. AMOPS. When notified, will begin an airfield search and keep Tower informed of status until situation is resolved.
 - 5.8.1.2. CMH Approach Control.
 - 5.8.1.3. Indianapolis ARTCC.
- 5.8.2. Tower will keep above agencies informed of changes in status of PLB, CPI or ELT signal.

5.9. Hung Ordnance/Jammed Gun/Hot Gun Procedures (See [Attachment 8](#)).

- 5.9.1. Aircraft landing or identified during post flight recovery with hung ordnance/jammed gun/hot gun or unsafe ordnance shall inform Tower of their weapon's status.
- 5.9.2. Aircraft with hung ordnance/jammed gun/hot gun shall be parked on Hot Cargo Pad 4 with the aircraft headed in a southwesterly direction, and in such a manner so as to not endanger operations on adjoining pads, until qualified personnel can de-arm/safe the weapon.

5.9.3. Tower will activate the PCAS whenever there are aircraft with hung ordnance/jammed gun/hot gun or unsafe ordinance.

5.9.4. AMOPS will:

5.9.4.1. Activate the SCN

5.9.4.2. Notify the National Park Service (Huffman Prairie Flying Field), and SFS whenever there are such aircraft parked on Hot Cargo Pad 4.

5.9.4.3. Contact EOD to respond and pin aircraft only in emergency situations. *After hours:* contact AFMC Command Center to dispatch EOD.

5.9.5. Tower will avoid taxiing aircraft into an area or position that could threaten personnel or equipment.

5.9.6. 788 CES/CEXD (EOD) will remove hung flare on the north warm-up pad if hung chaff/flares are discovered during post flight recovery of 445 AW assets. Secondary location for 445 AW asset hung flare will be Hot Cargo Pad 4.

5.10. Hydrazine Response Procedures.

5.10.1. If an F-16 reports Emergency Power Unit (EPU) activation, the FD will act to isolate the aircraft from equipment and personnel, and will work to safe the aircraft and flight crew. **NOTE:** *Hydrazine is a toxic and highly flammable liquid having the physical properties similar to oily water with an ammonia odor.*

5.10.2. When a hydrazine incident is anticipated or suspected the following actions will be taken:

5.10.2.1. Tower will:

5.10.2.1.1. Activate PCAS, indicating a hydrazine incident is suspected.

5.10.2.1.2. If the aircraft is able to taxi and the PIC concurs, instruct aircraft to the appropriate holding area (See [Attachment 8](#)):

5.10.2.1.2.1. Landing RWY 23R: Exit RWY and hold on TWY Bravo South until further instructions from FD.

5.10.2.1.2.2. If the aircraft is not able to taxi, direct aircraft to hold position on the RWY.

5.10.2.1.2.3. Landing RWY 05L: Exit RWY and hold on TWY Bravo between RWY 05L departure end and RWY 05R departure end until further instructions from FD.

5.10.2.1.3. Coordinate with the IC to isolate the aircraft from equipment and personnel obtain affected cordon with ECP and obtain crash grid and Military Grid Reference System (MGRS) coordinates.

5.10.2.1.4. Restrict airspace as appropriate and request AMOPS to send applicable NOTAM.

5.10.2.2. AMOPS will notify airfield users of hydrazine incident and relay the affected cordon/ECP location, adhere to OSAM OI 13-201 and complete the following: **NOTE:** *Non-essential vehicles and personnel only increase danger of injury and hamper the operation of the rescue and recovery team and shall remain clear of the cordon and maintain radio silence.*

5.10.2.2.1. AMOPS will not respond to the airfield until the IC deems area “safe.”

5.10.2.2.2. AFM or designated representative will coordinate with the IC for continued airfield operations.

5.10.2.2.3. Close/restrict/suspend affected airfield/airspace surfaces as appropriate.

5.10.2.3. The IC will accomplish the following:

5.10.2.3.1. Direct emergency response vehicles/operations.

5.10.2.3.2. Establish affected cordon, ECP, crash grid and MGRS coordinates.

5.10.2.3.3. Coordinate with Tower.

5.10.2.3.4. Coordinate with AFM or designated representative for continued airfield operations, as appropriate. Request response from AM as necessary IAW Hydrazine Response Team (HRT) LOA.

5.10.2.3.5. Coordinate with the HRT.

5.10.2.3.6. Advise Tower and AFM of the estimated delay time until resumption of normal airfield operations is possible.

5.11. Wind Limitations on Patterson Tower.

5.11.1. Patterson Tower is able to withstand wind (gusts/sustained) up to 88 knots. Tower will evacuate at 70 knots (gusts/sustained). Tower WS may evacuate at a lower wind speed if it is deemed necessary for safety.

5.11.2. Tower personnel will relocate to AMOPS.

5.12. Evacuation of Airfield Operations Facilities.

5.12.1. Evacuation of Tower:

5.12.1.1. There is no fixed alternate Control Tower at WPAFB.

5.12.1.2. If Tower is evacuated, air traffic control services shall be suspended and the airfield will temporarily close. In the event of a tornado, personnel will relocate to the designated tornado shelter in building 206. In the event of any other evacuation, Tower personnel will evacuate to designated areas as appropriate.

5.12.1.3. Tower evacuation procedures:

5.12.1.3.1. Tower will accomplish the following (time permitting):

5.12.1.3.1.1. Activate PCAS and relay all pertinent information, (i.e., reason for evacuation, traffic conditions, field conditions, etc.).

5.12.1.3.1.2. Notify CMH Approach Control of evacuation and relay all pertinent information and status of NAVAIDs.

5.12.1.3.1.3. Time permitting, broadcast an evacuation notice three times on all frequencies including 243.0/121.5.

5.12.1.3.1.4. Broadcast evacuation notice on the ATIS.

5.12.1.3.1.5. Transfer control of airfield lighting to AMOPS.

5.12.1.3.1.6. Time permitting; notify WX if evacuation is based on a significant weather observation.

5.12.1.4. AMOPS will accomplish the following:

5.12.1.4.1. Process NOTAMs as appropriate.

5.12.1.4.2. Notify local flying units and other base agencies that are affected.

5.12.2. Evacuation of AMOPS:

5.12.2.1. The primary evacuation facility is located at Building 101, Room L-116.

5.12.2.1.1. The 445th will provide AMOPS alternate facility IAW the LOA between 445th AW and 88 OSS, *Alternate Airfield Management Operations (AMOPS) Facility*:

5.12.2.2. Service restrictions/delays may be encountered due to limited resources (i.e., telephones, computers, FLIP's, etc.).

5.12.2.3. AMOPS will notify the following agencies of evacuation/arrival at alternate facility:

5.12.2.3.1. Tower.

5.12.2.3.2. CMH Approach Control.

5.12.2.3.3. AFMC CP.

5.12.2.3.4. 445 CP.

5.12.2.3.5. FD.

5.12.2.4. AMOPS will complete the following:

5.12.2.4.1. Process NOTAMs as appropriate.

5.12.2.4.2. Complete applicable checklists/QRCs.

5.12.2.5. If Tower is not evacuating, Tower will maintain communication with AMOPS via LMR until AMOPS reports arrival at alternate facility.

5.12.2.6. Request Tower to monitor Pilot-To-Dispatch frequencies until AMOPS can monitor frequencies at evacuation site.

5.12.3. When it is safe to return to the primary facility, Tower and AMOPS will notify affected agencies when services are restored.

5.13. Alternate Facility Procedures.

5.13.1. Patterson Tower does not have a dedicated alternate facility.

5.13.2. AMOPS Procedures:

5.13.2.1. AMOPS alternate facility is located at Bldg 101, Room L-116. Complete all actions in **paragraph 5.12.2**, and locally derived checklists/QRCs IAW OSAM OI 13-201.

5.14. Earthquake Procedures.

5.14.1. Upon notification or observation of earthquake in progress, Tower will advise taxiing aircraft to stop and shut down engines until the airfield can be checked.

5.14.2. AMOPS will perform an airfield check prior to resuming airfield activities.

5.15. Preventing and Resisting Aircraft Piracy (Hijacking) Procedures. The 88 OSS/OSA, Airfield Operations Flight, will adhere to the WPAFB Preventing and Resisting Aircraft Piracy (Hijacking) Plan, AFI 13-207-O, *Preventing and Resisting Aircraft Piracy (Hijacking)*, and FAA 7610.4, *Special Operations*.

Chapter 6

OTHER EMERGENCY PROCEDURES AS LOCALLY DETERMINED (SIMULATED FLAME-OUT, PRECAUTIONARY APPROACHES)

6.1. Simulated Flame-out (SFO) Approaches (Overhead and Straight-in).

6.1.1. Description:

- 6.1.1.1. Procedures apply only to F-16 aircraft assigned to the 180 FW from Toledo, OH.
- 6.1.1.2. Patterson Tower and CMH Approach shall exchange information for relay to SFO aircraft.
- 6.1.1.3. Patterson Tower shall apply standard ATC procedures while handling these operations.
- 6.1.1.4. Patterson Tower and CMH Approach may disapprove SFOs because of traffic or other reasons, either before or after the start of the maneuver.
- 6.1.1.5. SFOs shall only be approved between official sunrise and sunset.
- 6.1.1.6. SFOs shall only be requested/approved when Patterson Tower is operational.
- 6.1.1.7. SFOs shall only be flown to RWY 23R and RWY 05L.
- 6.1.1.8. Opposite direction operations are prohibited when SFOs are in progress.
- 6.1.1.9. Maximum airspeed for Straight-In SFOs (SI-SFO) will be 250 knots.
- 6.1.1.10. PICs shall continue to squawk assigned transponder code unless otherwise directed by ATC.
- 6.1.1.11. All SFOs and SI-SFOs shall be verbally coordinated and approved by Patterson Tower based on local conditions and traffic.
- 6.1.1.12. Unless otherwise coordinated, CMH Approach shall obtain approval from and transfer communications to Patterson Tower prior to 10 NM from the airport, forwarding callsign, number in flight, position and SFO procedure to be flown.
- 6.1.1.13. When SFOs are in progress, CMH Approach and Patterson Tower shall control traffic so as to remain clear of the immediate vicinity of the SFO pattern.

6.1.2. SI-SFO (see [Attachment 11](#)).

- 6.1.2.1. Maneuvering altitude shall be requested by the PIC or assigned by ATC, 8,000-10,000 ft MSL, descent beginning 7-10 NM from the end of runway.
- 6.1.2.2. The aircraft must be aligned with +/- 5 degrees at 6 DME for RWY 23R and RWY 05L.
- 6.1.2.3. CMH Approach shall coordinate with Patterson Tower prior to approving SI-SFO.
- 6.1.2.4. CMH Approach shall not sequence any aircraft in front of a 10-mile SI-SFO except for another SI-SFO. Once an aircraft commences the SI-SFO, that aircraft is number one to the runway IAW SFO *Letter of Agreement* (LOA).

6.1.2.5. SI-SFOs will be flown as a single ship or flight of two. If the flight of two is non-standard, inform CMH approach and Patterson Tower prior to commencing SI-SFO.

6.1.2.6. The following position reports shall be made by the 180 FW PICs and Patterson Tower:

6.1.2.6.1. PIC: "PATTERSON TOWER, (Aircraft ID), (number in flight), 10-MILE STRAIGHT-IN SIMULATED FLAMEOUT FINAL, AIRPORT IN SIGHT."

6.1.2.6.2. Control Tower: "(Aircraft ID), PATTERSON TOWER, REPORT 6-MILE SIMULATED FLAMEOUT FINAL."

6.1.2.6.3. PIC: "PATTERSON TOWER, (Aircraft ID), 6-MILE SIMULATED FLAMEOUT FINAL, GEAR DOWN."

6.1.2.6.4. Control Tower: "(Aircraft ID), (wind), RUNWAY (number), CLEARED LOW-APPROACH (or alternate instructions)."

6.1.2.7. Should traffic or other considerations preclude continuation of the SI-SFO at 6 DME, Patterson Tower shall instruct the aircraft to abandon the approach and issue alternate instruction, coordination with CMH Approach as necessary.

6.1.2.8. Weather Requirements:

6.1.2.8.1. SI-SFOs are only authorized when the ceiling is above 10,000 ft AGL and the visibility is at least 5 statute miles.

6.1.3. **Overhead SFO** (see [Attachment 12](#)).

6.1.3.1. High Key altitude shall be no higher than 10,000 ft MSL and Low Key altitude shall be 4,000 ft MSL to 6,000 ft MSL or as requested by the PIC and assigned by ATC.

6.1.3.2. Aircraft shall make right turns for RWY 23R or left turns to RWY 05L or as designated by Patterson Tower.

6.1.3.3. Maneuvering airspace shall be limited to a 4 NM radius of the geographical center of the airport.

6.1.3.4. Once the SFO is approved by CMH Approach and Patterson Tower, CMH Approach shall consider the pattern in use (HOT) at or below the Low/High Key altitude approved until advised otherwise by Patterson Tower.

6.1.3.5. Patterson Tower will advise the PIC of the estimated delay if an SFO cannot be granted upon request. In the event a PIC is not cleared for an immediate SFO, the aircraft shall continue to orbit at High Key within 4 NM of the geographical center of the airport.

6.1.3.6. PICs shall make "High Key/Low Key, and/or Base Key" radio calls.

6.1.3.7. Weather Requirements:

6.1.3.7.1. Overhead SFOs are only authorized when the ceiling is at least 1,000 ft above the approved High Key altitude and the reported flight and ground visibility is at least 5 statute miles.

Chapter 7

FLIGHT PLANNING PROCEDURES

7.1. Flight Planning Procedures. Flight plan procedures will be IAW AFMAN 11-213, AFMAN 13-204V2, FLIP General Planning and applicable LOAs.

7.1.1. Aeronautical Information System – Replacement (AIS-R). AMOPS is equipped with the Federal Aviation Administration (FAA) AIS-R, worldwide telecommunications system and will utilize this system for the following:

7.1.1.1. AMOPS assumes all flight following and flight plan transmission duties and responsibilities through the AIS-R to include IFR/VFR flight plans, flight notification, en-route change of destination, and other relevant messages as applicable to appropriate ATC facilities, FAA Air-Route Traffic Control Center (ARTCC) facility, FAA Flight Service Stations (FSS), AMOPS facilities, and other interested agencies.

7.1.2. Original flight plans must be filed in person unless there is an exception noted below. Original flight plans will not be accepted via radio. All flight plan(s) must be filed with AMOPS IAW the following:

7.1.2.1. PIC Flight Planning Responsibilities:

7.1.2.1.1. 445th AW is authorized to utilize Foreflight for filing of flight plans in accordance with the below procedures.

7.1.2.1.1.1. When filing flight plans utilizing Foreflight, the PIC or designated representative will ensure AMOPS receive the flight plan via organizational email at 88OSS.BaseOPS@us.af.mil and by entering KFFOYXYX into the addressee(s) section. NOTE: This can be accomplished by entering the organizational email in the “send to” feature or utilizing it as the pilot’s email address.

7.1.2.1.1.1.1. The electronic flight plan (e-FP) sent to AMOPS must contain all the required information necessary to process the e-FP (i.e. type acft, call-sign, tail number, proposed departure date/z- time, valid route of flight, estimated time enroute, aircrew names, and any requested services at the destination). NOTE: The flight crew authorization must be maintained at the squadron when filing through Foreflight.

7.1.2.1.1.1.2. The PIC or designated representative will verify receipt of the e-FP with AMOPS at extension 257-4492/3616. They will also verify they received a roger message before stepping to the aircraft. Verification will be required prior to engine start; furthermore, the PIC understands filing less than 30 minutes from the intended departure time may result in delayed clearance.

7.1.2.1.1.2. The PIC understands that AMOPS is unable to edit e-FPs filed on Foreflight and will utilize the below primary and backup procedures for amending the e-FPs if necessary.

7.1.2.1.1.2.1. Primary: Amend the e-FP utilizing Foreflight through any available internet network access then contact AM via pilot to dispatch or extension 257-4492/3616 to verify receipt. NOTE: The pilot should allow three minutes for the e-FP to populate in AMOPS email org inbox.

7.1.2.1.1.2.2. Back-up: If an internet connection cannot be established, the pilot will amend the e-FP by calling the flight service station.

7.1.2.1.1.3. Once AMOPS receives an e-FP from Foreflight, the e-FP (DD Form 1801 or other format) will constitute as the “original flight plan”. AM will process the original e-FP following established procedures, notify tower, send departure message(s), implement flight following, etc. AM will print the e-FP and file in the same manner as an original DD 1801 flight plan.

7.1.2.1.2. 445 AW will annotate engine running offload/onload (ERO), engine running crew changes (ERCC), call-sign changes, NVD ops in the remarks section of the DD Form 1801. Example: “ERO”, “ERCC”, “NVD”, etc.

7.1.2.2. Transient PICs Flight Planning Responsibilities:

7.1.2.2.1. U.S. Air Force Transient PICs:

7.1.2.2.2. Must file flight plans in person unless flight plan was processed by a MAJCOM Flight Planning Cell IAW AFMAN 13-204V2. AMOPS will not modify/change flight plans for Flight Managed Missions without approval from the flight planning cell/flight managers (*IAW AFI 11-255V3, Flight Manager Responsibilities and Procedures*).

7.1.2.2.3. PICs from the 89th Airlift Wing, Joint Base Andrews and 55th Wing, Offutt AFB may file an electronic non-alert flight plan solely through Jeppesen but must still contact AMOPS in person, via Pilot-to-Dispatch or by land line to confirm receipt. If no flight plan is received via AIS-R message originating from “KDENXLDI”, the PIC must provide AMOPS with a signed copy at least one hour prior to departure. The 89th Airlift Wing and 55th Wing will ensure flight plans filed through Jeppesen are kept on file IAW Air Force RDS, Table 13-07, Rule 3.00.

7.1.2.3. Non-U.S. Air Force Military Transient PICs:

7.1.2.3.1. Must file flight plans (DD Form 1801) or provide a hard copy of an electronically filed flight plan in AMOPS. If a transient aircraft has full stopped at Patterson Field, and a flight plan is not stored in FAA system(s), and AMOPS cannot verify an original flight plan clearance was filed from the original departure location, the aircraft will not be approved for engine run, taxi, or departure from Patterson Field, until a flight plan has been processed and received with an original signature.

7.1.2.4. Foreign Military:

7.1.2.4.1. Must file an accurate flight plan (DD Form 1801) with an original signature, prior to engine start, taxi, and departure from Patterson Field.

7.1.2.5. Civilian Transient PICs:

- 7.1.2.5.1. Must file an accurate flight plan (DD Form 1801) and/or hard copy of an electronic computer generated flight plan) with AMOPS. If PIC filed an electronic computer generated flight plan, PIC must provide a copy of the flight plan prior to engine start, taxi, and departure from Patterson Field.
- 7.1.2.6. Temporary Bed Down Aircraft
- 7.1.2.6.1. When on station, temporary bed down aircraft are authorized to file a DD Form 1801, Tanker Airlift Control Center (TACC) electronic filed flight plan, via fax, email, and/or hand carried (in cases of telephone/computer communication outage.) The PIC is responsible for verifying receipt and accuracy of the flight plan with AMOPS via telephone call.
- 7.1.2.6.2. The bed down aircraft unit will maintain the original flight plan until end of flying day and deliver them to AMOPS to keep on file IAW Air Force RDS, Table 13-07, Rule 3.00 (NOTE: Flight Plans must be filed with Airfield Management Operations instead of third party sites such as 1800weather.com).
- 7.1.3. Any deviations from the original filed flight plan prior to ATC clearance issuance must be coordinated through AMOPS via telephone, fax, or radio. Tower will advise AMOPS of any deviations to the issued clearance (i.e. local pattern delays, route change, en-route time, etc.). **NOTE:** *If Tower cannot locate a clearance contact AMOPS for coordination.*

Chapter 8

MISCELLANEOUS PROCEDURES

8.1. Airfield Operations Board AOB Membership:

8.1.1. Mandatory Members:

- 8.1.1.1. 88th Air Base Wing (88 ABW/CV, Board Chairperson).
- 8.1.1.2. 88th Mission Support Group Commander (MSG/CC)
- 8.1.1.3. 88th Communication Group Commander (CG/CC)
- 8.1.1.4. 445th Airlift Wing (445 AW).
- 8.1.1.5. 55th Airlift Wing (55 AW).
- 8.1.1.6. Flight Safety (88 ABW/SEF, 445 AW/SE).
- 8.1.1.7. Commander, Operations Support Squadron (88 OSS/CC).
- 8.1.1.8. Commander, Airfield Operations Flight (AOF/CC).
- 8.1.1.9. Control Tower Chief Controller (88 OSS/OSAT).
- 8.1.1.10. Airfield Manager (88 OSS/OSAA).
- 8.1.1.11. Base Weather (88 OSS/OSW).
- 8.1.1.12. CMH Approach Control (FAA).
- 8.1.1.13. Civil Engineer Group (88 ABW/CEG).
- 8.1.1.14. Logistics Readiness (88 MSG/LGR).
- 8.1.1.15. Communications (88 CS/CC).
- 8.1.1.16. RAWs (88 OSS/OSM).

8.1.2. Members Not Required to be Present:

- 8.1.2.1. Terminal Instrument Procedures Specialist (TERPS).
- 8.1.2.2. WPAFB E-4B Liaison (88 ABW/XPX).

8.2. AOB Mandatory Review Board Briefing Requirements.

8.2.1. Quarterly. The AOB mandatory quarterly briefing items are outlined in AFMAN 13-204V1, *Management of Airfield Operations*, Attachment 3, and will be briefed at every AOB Quarterly meeting.

8.2.2. Annual. AOB must review annually IAW AFMAN 13-204V1, *Management of Airfield Operations*, see **Table 8.1** for annual review items.

Table 8.1. AOB Annual Review Items.

Results of annual self-inspection	June
Special Interest Items	June
TERPS	June
Aircraft Parking Plan	June
Results of Annual Airfield Certification and Safety Inspection	July
Letters of Procedure	July
Waiver Package	December
ICEMAP	December
Base OPLANS	As directed by 88 ABW/XP

8.3. Notice to Air Missions (NOTAM) Procedures.

8.3.1. Airfield Management is the designated primary airfield NOTAM facility monitor for Wright-Patterson AFB. The AFM will coordinate with AMOPS to ensure appropriate NOTAMs are sent to provide advanced notification to aircrews of local airfield/airspace restrictions or deviations from published information.

8.3.2. AMOPS will process NOTAMs IAW AFI 11-208_IP.

8.4. FLIP Accounts, Procedures for Requesting Changes.

8.4.1. Non-Procedural and DoD FLIP changes will be coordinated and approved through AOF/CC.

8.4.2. Procedural changes to Instrument Approach Procedures (IAP) will be coordinated through the AOF/CC and approved by HQ AFMC/A300 (TERPS).

8.5. Prior Permission Required (PPR) Procedures.

8.5.1. Patterson Field is PPR only and pertinent information is published in the IFR Supplement.

8.5.2. All transient aircrew/aircraft must obtain a PPR number generated by AMOPS.

8.5.2.1. AMOPS or designated representative will generate and monitor all PPR numbers issued to aircrew and will de-conflict any issues that may arise due to airfield restrictions/event(s) prior to issuance IAW OSAM OI 13-201.

8.6. Air Evacuation Notification and Response Procedures.

8.6.1. Tower will notify AMOPS and TA at or before 10NM from the runway, via the “DV Line.”

8.6.2. AMOPS will:

8.6.2.1. Upon receipt of PPR, notify WPAFB Medical Center Emergency Room (ER).

8.6.2.2. Notify the WPAFB Medical Center ER and FD dispatcher upon notification of an inbound AIREVAC aircraft.

8.6.2.3. Pass special medical requests and 10-mile final approach alert when provided by Tower to the Fire Department and Emergency Room. The AIREVAC Checklist will be completed and events recorded on the AF Form 3616. **NOTE:** *Per AFI 10-001 and AFMAN 13-204 V2 para 6.1.5., civil aircraft transporting critically ill or injured individuals to or from WPAFB are not required to obtain a Civil Aircraft Landing Permit (CALP), exempt from OBO/PPR restrictions, but are required to obtain a PPR number for tracking and notification.*

8.6.3. Care Flight/Life Guard operations off the airfield but on base will be the responsibility of the IC.

8.7. Unscheduled/Unauthorized Aircraft Arrivals.

8.7.1. In the event of an unscheduled military aircraft, AMOPS shall obtain and log required flight data from crews of military aircraft that arrive without prior notification.

8.7.2. All aircraft that land without prior authorization from AMOPS shall be handled IAW *WPAFB Preventing and Resisting Aircraft Piracy (Hijacking) Plan*.

8.8. Distinguished Visitor (DV) Notification Procedures.

8.8.1. AMOPS will:

8.8.1.1. Request a 10 NM notification on the arrival of a DV aircraft, utilizing the IDS5.

8.8.1.2. Complete all actions as required by local derived checklists/QRC's.

8.8.2. Tower will make a single landline notification via "DV" line to AMOPS and TA of DV aircraft at or before 10 NM from the runway. **NOTE:** *Ramp Isolation/Quiet Hours Procedures may be required for military/civilian DV code 3 or above. Refer to paragraph 1.27 for further details.*

8.8.3. TA and AMOPS will coordinate daily for DV parking.

8.9. Dangerous/Hazardous Cargo. Refer to paragraph 1.18., Table 1.18., 1.18.1., 18.2., Airfield Restrictions.

8.9.1. Stub8 Operations.

8.9.1.1. Safe Haven and Secure Hold for Department of Energy and DoD Drivers is located on Stub8 A/B located on the east side of the airfield adjacent to the base golf range.

8.9.1.2. Stub8 A is located outside the airfield fence and accessible from the airfield side only. Stub8 B is entirely on the airfield and also accessible only from the airfield side.

8.9.1.3. Procedures will be followed IAW WPAFBI 31-101, Appendix 13 to Annex M-13-1, M-13-2.

8.9.2. The following guidelines apply to parking an aircraft loaded with explosive materials and armament in order of preference:

8.9.2.1. Hot Cargo Pads (HCP) 1 through 4: All Hazard Class/Division (HC/D). **NOTE:** Aircraft with a tail height higher than 49 ft will not be parked on HCP 2 whenever possible due to a 50:1 Approach/Departure Clearance Surface violation for RWY 05R/23L.

8.9.2.2. Hotel 1 through 4. Only explosive-loaded aircraft may park next to another explosive-loaded aircraft (no non-explosive loaded aircraft).

8.9.2.3. India 1 and 2: Only used for HC/D 1.4 cargo; no parking restrictions (e.g. may park non-explosive loaded next to explosive loaded).

8.9.2.4. TWY Alpha south of TWY Charlie: Emergency only (All HC/D).

8.9.2.5. Park aircraft with exempt explosive devices at designated aircraft parking spots or hangar these aircraft IAW DESR 6055.09 AFMAN91-201, *Explosives Safety Standards*, and Technical Order (TO) 11A-1-33, *Handling and Maintenance of Explosives Loaded Aircraft –(ATOS)*. (See **Table 8.2** and *Figures 1.1.* & *1.2.*, *Authorized Parking Areas for Aircraft Carrying Explosives.*)

8.9.3. Clear zones.

8.9.3.1. 88 ABW/SEW is responsible for defining necessary clear zones.

8.9.3.2. Any HC/D 1.1 and 1.2.1 will have clear zones of 1250 and 1260 feet, respectively.

8.9.3.3. HC/D 1.4 will have a clear zone of 100 feet.

8.9.3.4. Any other HC/D clear zones will be determined by 88 ABW/SEW.

8.9.3.5. Non-mission related personnel are not authorized access into defined clear zones (e.g., mowers, USDA, contractors, etc. are non-mission related personnel).

Table 8.2. Authorized Parking Areas for Aircraft Carrying Explosives.

	Explosive Hazard Class and Division	Quantity in Pounds
Hot Cargo Pads 1-4***	(12)1.1	Daily Tier: 30,000 NEW#
“	1.2.1>450 Max Credible Event	Daily Tier: 30,000 NEW
“	1.2.2	Daily Tier: 30,000 NEW
“	(12)1.2.3</=450 Max Credible Event	Daily Tier: 30,000 NEW
“	1.3	Daily Tier: 100,000 NEW
“	1.4	PC*
Stub 8A and Stub 8B	(12)1.1	30,000 NEW
	1.2.1>450 Max Credible Event	30,000 NEW
	1.2.2	30,000 NEW
	(12)1.2.3</=450 Max Credible Event	30,000 NEW

	1.3	100,000
	1.4	PC*
TWY A (Spots 1-11)**	(12)1.1	30,000 NEW
”	1.2.1>450 Max Credible Event	30,000 NEW
“	1.2.2	30,000 NEW
“	(12)1.2.3</=450 Max Credible Event	30,000 NEW
“	1.3	100,000 NEW
“	1.4	PC*
Parking Spots H-1	1.3	5,000 NEW
	1.4	PC*
Parking Spots H-2 thru H-4	1.2.2	5,000 NEW
	1.3	20,000 NEW
	1.4	PC*
Parking Spots I-1 & I-2	1.4	PC*
Parking Spots A-1 – A-9	1.2.2	50,000 NEW
Parking Spots A-10	1.2.2	29,000 NEW
Parking Spots A-11 – A-12	1.2.2	16,000 NEW
Parking Spots A-13	1.2.2	19,000 NEW
Parking Spots A-14	1.2.2	30,000 NEW
Parking Spots A-1 – A-14	1.3	65,000 NEW
(West Ramp)	1.4	MEQ*
	WARTIME CONDITIONS - HAZARDOUS CARGO PADS	
HAZPAD 1 and 2***	1.1	68,000 NEW
	1.2.1	100,000 NEW
	1.2.2	100,000 NEW
	1.2.3	100,000 NEW
	1.3	250,000 NEW
	1.4	PC*
HAZPAD 3 and 4***	1.1	105,000 NEW
	1.2.1	100,000 NEW
	1.2.2	100,000 NEW
	1.2.3	100,000 NEW
	1.3	250,000 NEW
	1.4	PC*

#NEW = Net Explosive Weight (in lbs).
 MEQ = Mission Essential Quantities
 **TWY Alpha = - Static grounds required to be installed by CE prior to use.
 ***Hot Cargo Pads 1-4 transition to Hazardous Cargo Pads (HAZPADS) 1-4 in wartime conditions or if weight limits for HC/Ds 1.1 and/or 1.2.1 are exceeded

Figure 8.1. Hotel and India Row Explosives Safety Clear Zone.

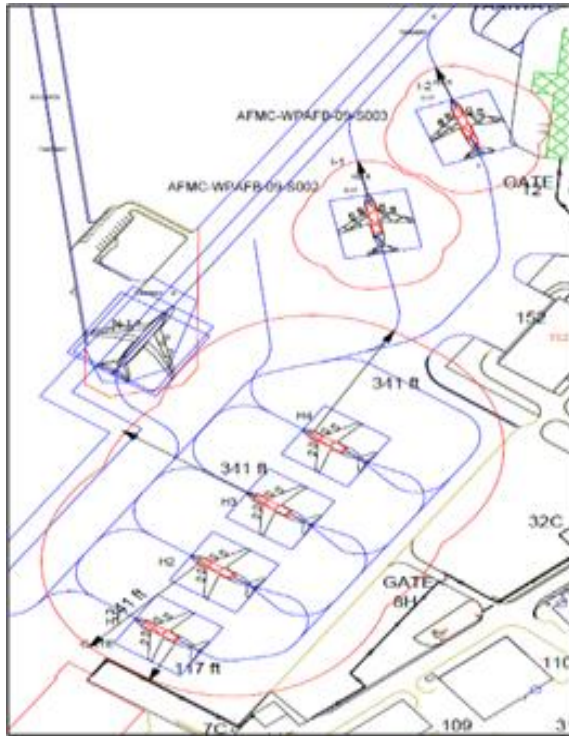

Figure 8.2. West Ramp Explosives Safety Clear Zone.



8.10. Night Vision Device (NVD) Operations.

- 8.10.1. Patterson Field AMOPS personnel are not equipped with NVDs.
- 8.10.2. NVD airfield operations are conducted at Patterson Field IAW *C-17A Portable Night Vision Device (NVD) Lighting Operations LOA*. NVD procedures are only authorized by units designated in a *C-17A Portable Night Vision Device (NVD) Lighting Operations LOA*.
- 8.10.3. Operating a vehicle or equipment with NVDs is not authorized on Patterson Field.

8.11. Local Aircraft Priorities: Aircraft priorities set by 14 CFR, *Aeronautics and Space, Part 91*, FAA JO 7110.65, *Air Traffic Control*, and this instruction are:

- 8.11.1. Emergency aircraft (aircraft in distress have right of way over all other traffic).
- 8.11.2. Air Evac/MED EVAC.
- 8.11.3. Search and Rescue.
- 8.11.4. Flight Check.
- 8.11.5. E-4B Alert.
- 8.11.6. TACC-directed missions.
- 8.11.7. Distinguished Visitors (DV).
- 8.11.8. Hurricane Evacuation (HUREVAC) aircraft.
- 8.11.9. Scheduled IFR arrivals/departures.
- 8.11.10. TAD Procedures/Training Missions.
- 8.11.11. NVD Procedures.
- 8.11.12. Jump operations. **NOTE:** *These priorities are not absolute. ATC will adjust as necessary to affect minimum delay based on the actual traffic mix using good judgment.*

8.12. Aircraft Lost Communications Instructions.

- 8.12.1. No radio (NORDO) is treated as an emergency unless the PIC has signaled that radio failure is the only problem, using procedures in the FLIP Flight Information Handbook. Tower is able to give landing instruction on all appropriate frequencies and by light gun signals.

8.13. Standard “Climb-Out” Instructions.

- 8.13.1. Standard “Climb-out” for initial IFR departures is “FLY RUNWAY HEADING, MAINTAIN 3,000.”
- 8.13.2. Standard “Climb-out” for SVFR/Class C Participants/Flight Following is “maintain AT OR BELOW 2,500, FLY RUNWAY heading.”
- 8.13.3. Standard Climb-out for multiple instrument/practice approaches is “CLIMB AND maintain 3,000, FLY heading 140.”
- 8.13.4. When overhead pattern is in use tower shall amend “Climb-out” for departing aircraft to “MAINTAIN AT OR BELOW 1,900 UNTIL DEPARTURE END.”

8.14. Opposite Direction Take-Offs and Landings.

8.14.1. Requests for opposite direction IFR arrivals or departures will be coordinated between Patterson Tower and CMH Approach Control.

8.14.1.1. Requestor will state the landing runway when an aircraft is conducting a circling approach.

8.14.2. The following separation standards shall be followed:

8.14.2.1. IFR Arrival versus IFR Arrival. Arriving aircraft shall not proceed closer than 10 NM final to the runway in use until the opposite direction aircraft has landed or circling aircraft has crossed the landing threshold.

8.14.2.2. IFR Arrival versus IFR Departure. Departing aircraft must be established on a diverging course and changed to CMH Approach's frequency prior to the arriving aircraft reaching 10 NM final.

8.14.2.3. IFR Arrival versus VFR Departure. VFR departures shall be airborne and turned to avoid conflict prior to IFR arrival reaching 5 NM final for same runway operations.

8.14.2.4. VFR Arrival versus VFR Departure. Tower shall ensure that the departing VFR aircraft is airborne and turned to avoid conflict prior to the arriving VFR aircraft reaching 5 NM final. Appropriate advisories must be given to both aircraft prior to issuing takeoff clearance. **NOTE:** *This applies to same and parallel runway operations.*

8.14.3. All opposite direction operations are approved/disapproved by Patterson Tower.

8.15. Breakout/Go Around/Missed Approach Procedures.

8.15.1. Breakout/Go Around instructions will be issued by ATC.

8.15.2. Missed Approach procedures shall be IAW published Instrument Approach Procedures located within each FLIP.

8.16. Civilian Aircraft Operations.

8.16.1. AFM or designated representative is the approving authority for WPAFB Civil Landing Permit.

8.16.2. Civil aircraft require prior permission from AMOPS and an approved Civil Landing Permit to land at Patterson Field, unless exempt per AFI 10-1001.

8.16.3. PICs must coordinate with AMOPS 24 hours prior to landing at Patterson Field, to confirm PPR.

8.16.4. AMOPS coordinates with Tower prior to the estimated time of arrival (ETA) of known inbound civil aircraft authorized to land at Patterson Field.

8.16.5. If unable to determine approval status, Tower shall direct the aircraft to contact AMOPS on Pilot-To-Dispatch (PTD), see [Table 1.1](#) AMOPS will determine if the aircraft is authorized/unauthorized and inform Tower accordingly.

8.16.6. If the aircraft insists on landing and no known emergency exists, Tower shall take the following actions:

8.16.6.1. State that they are unable to issue a landing clearance, and request the PIC to restate intentions.

8.16.6.2. Immediately inform AMOPS.

8.16.6.3. Implement unauthorized landing procedures IAW *WPAFB Preventing and Resisting Aircraft Piracy (Hijacking) Plan*.

8.17. Gate 26A (Base Vehicle Inspection Gate) Operations.

8.17.1. AMOPS Gate 26A procedures will be conducted IAW the AMOPS 26A checklist.

8.18. Weather Dissemination and Coordination Procedures.

8.18.1. Hazardous/Severe weather notification procedures to include lightning response shall be IAW AFI 91-203 and WPAFBI 15-101, *Weather Support*.

8.18.2. When Base Weather disseminates a warning for observed lightning within ten (10) nautical miles of the airfield, notify all personnel working on the airfield of the weather warning. IAW [para. 8.18.3.2](#)

8.18.3. When Base Weather disseminates a warning for observed lightning within five (5) nautical miles of the airfield, notify all personnel working on the airfield that all outdoor activity on the airfield will cease (i.e. construction personnel, LEX, Barrier MX, ATCALs, etc.) and the following procedures apply:

8.18.3.1. All personnel, including military, civilian and contractors must seek shelter in a vehicle, aircraft or structure immediately after notification until the lightning warning has expired. The aircraft commander (AC) of an aircraft armed/loaded with hot/ hazardous cargo may elect to disembark the crew/passengers if remaining on the aircraft creates a greater danger to personnel. Ground support will respond to transport the crew/passengers to shelter. Ground support will not vacate the transportation vehicle and no other ground/ maintenance support will be provided. All maintenance, aerial port and fuel truck operations on the airfield are suspended.

8.18.3.2. Patterson Tower will inform all airborne aircraft of all lightning weather warnings issued for Wright-Patterson AFB.

8.18.3.3. Patterson GC and Patterson AMOPS will inform all aircraft and personnel monitoring the frequencies/LMR nets of all lightning weather warnings issued for Wright-Patterson AFB.

8.18.3.4. Aircraft arrivals: Aircraft are authorized to land and taxi, via “follow me” guidance, to an approved staging area. Crews and passengers will remain onboard the aircraft until the lightning warning has expired. Crews should not expect any ground support during the warning period.

8.18.3.5. Aircraft departures: If the aircraft engines are running, all crew members will remain on the aircraft. Departures are not authorized unless it is an extreme circumstance. Transient alert services will not be provided.

8.18.3.5.1. If aircraft engines are not running, all external preflight and loading operations will cease immediately. All crew members outside of the aircraft will either vacate the airfield to seek shelter or go inside the aircraft for cover. Once the lightning hold is lifted, the crew may resume preflight and load duties.

8.19. Variable Winds.

8.19.1. Tower will issue variable winds to base assigned aircraft IAW AFMAN 13-204V3, *Air Traffic Control*.

8.20. 445 AW Aircraft Ground Operations Concept Operations (CONOPS).

8.20.1. Aircraft ground operations are conducted at Patterson Field IAW Aircraft Ground Concept Operations LOA. Ground operation procedures are only authorized by units designated in an Aircraft Ground Concept Operations LOA.

8.21. Explosive Ordnance Disposal (EOD) Range Procedures.

8.21.1. 788 CES/CEXD EXPLOSIVE OPERATIONS.

8.21.1.1. EOD will not detonate more than five pounds of demolition explosive at one time IAW AFI 32-3001, unless performing emergency destruction operations with 88 ABW/CC approval.

8.21.1.2. When EOD personnel are on the EOD Proficiency Training Range for non-explosive related activities, prior coordination and continuous communications is not required. EOD personnel will contact AMOPS when entering and exiting the airfield.

8.21.1.3. The "Clear Zone" is a 500 foot radius around the EOD Proficiency Training Range and extends onto the airfield. A fence has been constructed around the Clear Zone to exclude non-essential personnel with the exception of the portion of the 500' cordon that extends within the airfield fence; no vehicles or pedestrians are permitted in the grass area east of Taxiway (TWY) Bravo, from TWY Delta to Hot Cargo Pad 4 during EOD Range activation. It is incumbent upon EOD personnel to remain vigilant that this area is clear of unauthorized personnel and to report any unauthorized movement inside the designated "Clear Zone" to Airfield Management. **NOTE:** "Clear Zone" radius is for training operations only; emergency detonation clear zone radius will be on a case-by-case basis.

8.21.1.4. EOD must perform the following to use the EOD Proficiency Training Range for explosive operations:

8.21.1.5. Notify Airfield Management 24 hours in advance via email at 88OSS.BaseOPS@us.af.mil to include: a POC with phone number at range during op, date of operation, number of detonations, start time, stop time, and Above Ground Level (AGL) affected.

8.21.1.6. Notify Airfield Management at least 1 hour prior to activating range. EOD will provide a specific start time, duration, AGL affected, and any changes compared to the email sent, if applicable.

8.21.1.7. During Emergency Destruction Operations, EOD will gain 88 ABW/CC approval and notify AMOPS of the location of emergency detonation, the cordon around the affected area and the AGL restriction.

8.21.1.8. EOD will raise range flag (burnt orange in color) for all explosive operations.

8.21.1.9. EOD will establish radio communications and coordinate with “Patterson Ground” on the Tower Net before activating the range for explosive operations. EOD will maintain communication until the operation terminates. Upon termination, EOD will notify Airfield Management.

8.21.1.9.1. EOD shall advise “1 minute from detonation” call to Patterson Ground.

8.21.1.9.2. EOD shall advise “detonation complete” call to Patterson Ground.

8.21.1.9.3. When termination of EOD activity is requested by Airfield Management or the Control Tower, EOD will immediately cease activity unless it represents a safety hazard (e.g. burning time fuse) and report stoppage to the Control Tower. Termination may be required at any time during these procedures. All airfield operations will take priority over explosive operations at EOD Proficiency Training Range. **NOTE:** In the event of a failed detonation attempt (misfire), the range must remain active for a minimum of 30 or 60 minutes depending on explosive setup to safely handle hazard.

8.21.1.10. In the event of an accident or fire, RSO or most available person will notify the Control Tower via the “TWR Net.” Tower will activate the Primary Crash Alarm System (PCAS). PCAS users: Fire Department, Airfield Management (AMOPS), Emergency Room (ER) and Flight Surgeon’s Office.

8.21.1.11. EOD will immediately notify the Control Tower and AMOPS of a misfire, the operations that the misfire effect and the estimated time that operations are required to be suspended.

8.21.1.12. After EOD misfire operations are complete the Control Tower and AMOPS will be notified.

8.21.2. Tower will.

8.21.2.1. Upon request of range activation by EOD, the Control Tower shall:

8.21.2.2. Provide positive control instructions to assist arriving/transitioning/air-taxiing aircraft from overflying the range below 500’ AGL while the EOD range is active. If a higher altitude restriction is required, EOD will notify the control tower of the appropriate altitude restriction.

8.21.2.3. To the maximum extent possible, tower personnel will report to Airfield Management any observed suspected unauthorized movements in the area around EOD Proficiency Range. **NOTE:** Normal training detonations do not require suspension of TWY Bravo to aircraft taxi or tow operations.

8.21.2.4. Blanket broadcast on the TWR net “EOD operations in progress at the EOD range.”

8.21.2.5. Notify AMOPS of “10 minutes from detonation” and “1 minute from detonation” call.

8.21.2.6. Ten minutes prior to detonation is latest tower can “knock-off” operations.

8.21.2.7. Notify AMOPS of “detonation complete” call.

8.21.2.8. Once “detonation complete” call is received from EOD, Tower may resume operations IAW [para 8.21.2.2](#).

8.21.3. Emergency Destruction Operations conducted at the EOD training range:

8.21.3.1. Terminate all taxi and tow operations on TWY Bravo south of TWY Delta. To the maximum extent possible, Tower personnel will remain vigilant and report to AMOPS any suspected unauthorized movement in the grassy area east of TWY Bravo from TWY Delta to Hot Cargo Pad 4 during these operations.

8.21.3.2. If notified by EOD, Tower will activate PCAS IAW [para 8.21.1.10](#).

8.21.3.3. Patterson Ground will broadcast any observed or reported lightning within 5 NM. **NOTE:** Emergency Destruction Operations that are conducted outside of the EOD training range may require different restrictions and NOTAMS than what is outlined in this AFBI, as determined by the Incident Commander.

8.21.4. AMOPS will.

8.21.4.1. Upon notification of pending explosive range operation activation by EOD, Airfield Management shall send the following Notice to Airmen (NOTAM): DEMOLITION OF EXPLOSIVES WILL TAKE PLACE AT THE EOD TRAINING RANGE LOCATED APPROXIMATELY 1000 FT EAST OF HOT CARGO PAD 3. AFFECTED ALTITUDE IS FROM SURFACE TO (INSERT ALTITUDE) FT AGL. **NOTE:** Emergency Destruction Operations may require different restrictions/NOTAM.

8.21.4.2. Complete EOD Range Quick Reaction Checklist and make all appropriate notifications.

8.21.4.3. Complete an airfield check to access the area and notify all agencies whose ground operations may be impacted. AMOPS will use whatever means possible to ensure all agencies are clear of the affected area and are notified via any means possible. These organizations include, but are not limited to: mowers, snow removal, sweeper, aircraft tow operations, USDA, Fleet Service, Air Freight, Airfield Lighting, National Park Service, and all contractors working on the airfield.

8.21.4.4. Make a blanket broadcast on the AMOPS net “EOD explosive operations in progress at the EOD range.”

8.21.4.5. Ensure no EOD explosive operations are conducted when explosive-laden aircraft parking, loading/unloading of hazardous cargo, and/or refueling takes place on Hot Cargo Pads 1-4 as concurrent operations pose a safety hazard. **NOTE:** Parking of aircraft without hazardous cargo is permitted during EOD explosive operations.

8.21.4.6. Explosive Training Operations:

8.21.4.6.1. Advise all agencies affected when EOD explosive operations have terminated.

8.21.4.6.2. Emergency Destruction Operations conducted at EOD training range: Prior to approving operation, suspend operations on TWY Bravo South of TWY Delta. Complete a check of the area and notify agencies that could be impacted.

8.21.4.6.3. Advise all agencies affected when EOD explosive operations have terminated.

8.21.4.6.4. After emergency destruction range activity terminates and prior to opening TWY Bravo, complete a FOD check of TWY Bravo (south of TWY Delta) and Hot Cargo Pads 1-4. Notify Control Tower and all affected agencies when normal operations can be resumed.

8.21.4.7. AMOPS will log all actions on the AF Form 3616, Daily Record of Facility Operation.

8.22. Bird/Wildlife Control: Local Bird/Aircraft Strike Hazard (BASH) Program.

8.22.1. WPAFB Bird/Wildlife Aircraft Strike Hazard (BASH) Plan establishes a BASH program and is designed to minimize aircraft exposure to harmful effects of bird and wildlife.

8.22.2. **RESPONSIBILITIES.** All required actions and responsibilities are outlined in the WPAFB BASH Plan. All personnel who work on/around Patterson Field and Wright Field should be alert for bird/wildlife activity and report such activity directly to Tower on the LMR Tower talk group and/or AMOPS on PTD frequency (UHF 372.2, VHF 126.2), landline, or the Base Ops LMR talk group. The responsibility to declare a bird watch condition lies (primarily) with AM. Upon observation or report of bird activity from any credible source, AM personnel will use the definitions in section 8.24 as a guide in determining bird watch conditions. Under MODERATE or SEVERE bird watch conditions, disperse bird concentrations as required.

8.23. Bird Watch Conditions (BWC).

8.23.1. BWCs are provided to indicate the level of activity around WPAFB, estimate the hazard, and allow aircrews and flying units to implement their internal BASH procedures. BWCs are based on continuous bird activity lasting for more than one minute. Large birds are considered any bird that appears or is known to weigh more than three pounds or more each. Small birds are all other birds. Conditions are defined as follows:

8.23.1.1. **BWC LOW.** Unless specifically notified of moderate or severe conditions, all agencies should assume a low condition is in effect.

8.23.1.1.1. Definition. Wildlife activity on and around the airfield representing low potential for strikes

8.23.1.1.2. Actions required. None.

8.23.1.2. **BWC MODERATE.** This condition requires increased vigilance by all agencies and supervisors and caution by aircrews.

8.23.1.2.1. Definition. Wildlife activity near the active runway or other specific location representing increased potential for strikes:

8.23.1.2.1.1. Actions required. All aircraft takeoff and landings allowed at the discretion of the aircraft commander. No transition training, simulated flameout, or formation landings/takeoffs allowed.

8.23.1.3. **BWC SEVERE.** Aircrews and supervisors must thoroughly evaluate mission needs before operating in areas under this condition. Aircraft operations will be suspended except for emergency or military operational necessity aircraft, which will be given priority.

8.23.1.3.1. Definition. Wildlife activity on or immediately above the active runway or other specific location representing high potential for strikes.

8.23.1.3.2. Actions required. Aircraft operations will be suspended except for emergencies. Non-emergency base assigned 445 AW aircraft operations must be approved by 445 AW/CC or designated representative no lower than 445 OG/CC. All other non-emergency aircraft operations must be approved by 88 ABW/CV.

8.23.1.4. Bird Watch Alert: Weather, time of day, and seasonal conditions that make an influx of birds onto the airfield likely.

8.24. Supervisor of Flying (SOF) Operating in the Tower.

8.24.1. The 445 AW and deployed units each have SOF programs that are only responsible for their own flying activity. SOF responsibilities and interface with other tenant units and the 88 Operations Support Squadron (88 OSS) are as follows:

8.24.1.1. Units administer their own SOF programs from vehicles or the Tower after receiving approval from the AOF/CC.

8.24.1.2. SOFs are responsible for the conduct of their unit's flying activities.

8.24.1.3. When advice is extremely technical, or when the SOF feels that relay of information by the Tower controller could cause an unacceptable delay, the SOF coordinates with the ATC facility WS or SC for permission to transmit directly to the affected aircraft. Limit instructions to preventing a mishap.

8.24.1.4. The SOF must not perform ATC functions or transmit ATC instructions or clearances to an aircraft. A person who commandeers an ATC frequency assumes responsibility for separation of aircraft.

8.24.1.5. SOFs or other unit representatives may provide assistance during transient aircraft emergencies upon request of AMOPS.

8.24.1.6. SOFs shall have no responsibilities to other flying units unless specifically requested to render assistance by AMOPS, or the commander/representative of another unit.

8.25. Airfield Photography.

8.25.1. Personnel requesting to take photos of the airfield environment, aircraft or system must coordinate with the AFM, 88th Security Forces Squadron Base Defense Operations Center as well as the aircraft/unit commander for the aircraft/system being photographed. Unofficial airfield photography should be coordinated 48-hours in advance with the above identified agencies and appropriate Public Affairs office (88 ABW/PA or 445 AW/PA). Further restrictions may be enforced IAW current wing guidance; contact 88th ABW/PA 937-255-2873 or 445th AW/PA 937-257-5784.

8.26. Wear of Hats/PPE.

8.26.1. Headgear will not be worn on the airfield.

8.26.2. Headgear/clothing authorized for extreme cold weather protection may be worn; however, every effort must be made to prevent such headgear from coming loose during duty performance. Special attention to the FOD potential and safety of personnel will be prime considerations when determining extreme cold weather clothing authorizations.

8.26.3. Personal protection equipment (PPE) is authorized during airfield construction activities. Every effort must be made to prevent such PPE from coming loose during duty performance. Special attention to the FOD potential and safety of personnel will be prime considerations when determining PPE authorizations.

8.27. Airfield Smoking Policy.

8.27.1. Smoking on the airfield is not authorized. Exception: Commanders and Directors may designate smoking areas that are located only on non-aircraft movement area sides of hangars or other airfield support facilities. Prior coordination with and approval by the Fire Emergency Services Flight and Airfield Manager is required.

8.28. Military Assumes Responsibility for Separation of Aircraft (MARSA) Procedures.

8.28.1. WPAFB conducts operations IAW FAA Order JO 7110.65 Air Traffic Control.

8.29. Customs, Agriculture, and Immigration.

8.29.1. Arrivals.

8.29.1.1. A customs, agriculture and immigration inspection is required for all aircraft, flight crew and cargo arriving from outside the Customs Territory of the United States (CTUS), which is defined as the 50 states, District of Columbia, and Puerto Rico. Space A passengers will not clear customs at Wright-Patterson AFB unless approved by Dayton U.S. Customs & Border Protection, Port Director.

8.29.1.1.1. Aircrew or mission scheduler(s) shall contact AMOPS at least 24 hours in advance of a scheduled arrival from a non-CTUS location and provide call sign, type of aircraft, country of origin, airport/country of departure prior to U.S., cargo/hazardous material status, number of crew and passengers, and estimated arrival and departure information.

8.29.1.1.2. Upon notification of an aircraft requiring customs, AMOPS shall coordinate requirements IAW local Customs/Agriculture/Immigration checklist.

8.29.1.1.3. U.S. Customs is subject to respond to all arrivals, however, may authorize designated Military Custom Officer Exempted (MCOe) assigned to 88 SFS to clear U.S. military aircraft arrivals from non-CTUS locations. If U.S. Customs responds, designated MCOe will assist with the agricultural portion of the inspection by removing and/or storing international trash.

8.29.1.1.4. Foreign aircraft arrivals from non-CTUS locations must be cleared by a U.S. Customs Officer. Designated MCOe will provide assistance, as required.

8.29.2. Departures.

8.29.2.1. All foreign aircraft require a notice to proceed prior to departure from Patterson Field. Aircrew and/or liaison shall provide AMOPS and 88 SFS with required information and grant inspectors access onto the aircraft.

8.29.2.2. Upon notification of an aircraft requiring a notice to proceed, AMOPS shall coordinate requirements IAW local checklists.

8.29.2.3. Designated MCOe can issue a permit to proceed to foreign aircraft as long as the aircraft had arrived Patterson Field from another U.S. port of entry. All others must receive clearance from U.S. Customs

8.29.3. Diplomatic Clearance Procedures for Canadian Forces

8.29.3.1. Routine flights through USA airspace or landing at military airfields (including USA territories) do not require diplomatic clearance or landing authorization. Flights transporting DV or hazardous materials require diplomatic clearance and landing authorization. For clearance purposes DV is defined as Cabinet Minister or above, or Lieutenant General or above. For clearance purposes hazmat is defined as class 1.1, 1.2, 1.3, 1.4, and 6.1. Aeromedical evacuation flights require both diplomatic clearance as well as landing authorization.

8.30. Aircraft Hurricane Evacuation (HUREVAC).

8.30.1. WPAFB airfield is a safe haven for hurricane evacuation (HUREVAC) aircraft. In the event of a natural disaster, the 88 OSS Special Operations Director will coordinate with AMOPS for the sheltering of applicable aircraft. AMOPS will complete the HUREVAC Checklist IAW the WPAFB HUREVAC Plan.

8.30.2. AFM and 88 OSS Special Operations Director will coordinate with TA to set up a HUREVAC Operations Parking Plan.

8.30.2.1. Any deviation from the original parking plan must be coordinated with the AFM, DAFM, or Special Operations Director.

8.30.3. To ensure safe, expeditious handling of aircraft, close coordination and mutual understanding is vital between AMOPS and TA during HUREVAC. Ensure TA is notified of any situation concerning:

8.30.3.1. Aircraft movement and recovery.

8.30.3.2. Aircraft parking restrictions.

8.30.3.3. Aircraft with special handling, such as:

8.30.3.3.1. AIREVAC.

8.30.3.3.2. Hazardous Cargo.

8.30.3.4. Maximum On Ground (MOG) issues. MOG issues may cause overabundance of aircraft, limited aircraft parking, limited support agencies and/or limited resources (e.g., fuel, fuel trucks, AGE equipment, personnel, and ramp space).

8.30.4. Hangar 206 utilization must be coordinated with the AFM, Building Manager and/or 88 OSS Special Operations Director.

Chapter 9

INFORMATION DISPLAY SYSTEMS (IDS5) PROCEDURES

9.1. IDS5 Network.

9.1.1. The IDS5 network is a real-time information dissemination system that is located in multiple agencies across WPAFB. First responders, command and control elements, and air traffic control are just a few of the work centers that utilize IDS5 for day-to-day operations. The IDS5 network consists of two types of computers: the Air Force Automated System (AFAS) and IDS Command and Control (IDS5-C2).

9.1.1.1. AFAS machines are configured as a “kiosk” which restricts access to any program on the computer other than IDS5. AFAS accesses the AF network via a service account which does not require a CAC card for authentication. By design, AFAS machines are not on the WPAFB domain and are exempt from some Group Policy Orders (GPO). AFAS machines are patched monthly by the AFAS Administrator or Sub-Administrators.

9.1.1.2. The IDS5-C2 is an application that is launched from a standard user desktop computer. IDS5-C2 users login to the base network via a CAC card and the system accesses the AFAS network via an interface. All required GPOs apply to an IDS5-C2 machine and it receives patches through the AF network.

9.2. IDS5 Security.

9.2.1. IAW the *Airfield Automation System Security Plan*, the following guidelines must be followed for protection of the IDS5 network.

9.2.1.1. Only authorized personnel and personnel with a need to know are granted access to IDS5 computers. Since AFAS machines do not require a CAC card for logon the machines must reside in a secure area (eg: locked office/cabinet or monitored 24/7) to prevent unauthorized access. WPAFB team members will use visual identification to ensure only authorized personnel gain system access; unauthorized people will be challenged and denied access.

9.2.1.2. All IDS5 users must be current with applicable COMPUSEC and Cyber Awareness training.

9.2.2. Classified information will not be transmitted on the IDS5 network.

9.3. IDS5 User Responsibilities.

9.3.1. The IDS5 network contains trusted information. Trusted information is defined as information that when received is accepted as authentic. Due to the negative impact that could result from unreliable information, no persons other than the IDS5 System Administrator or Sub Administrators are allowed to modify (Structure Edit) any IDS5 display page.

Chapter 10

CONTROLLED AREA

10.1. Airfield Controlled Area.

10.1.1. The airfield is a controlled area consisting of approximately 1,758 acres, delineated by 69,000 feet of marked chained link security fence, ranging from 8 to 10 feet tall. Forty-six entry points provide vehicle or personnel access to the airfield controlled area, excluding buildings.

10.1.2. Five main gates provide electronic airfield access: Gate 206N and 206S located on the north and south side of Building 206. Gate 4007 located on Vandenberg road between Hangar 4015 and 4007. Gate 4016 located adjacent to Hangar 4016 and Gate 10 located by Building 152. All other gates are operated by tenant organizations on an as-needed basis and are secured when not in use.

10.1.3. Personnel requiring access to the airfield controlled area (AA) must submit an AF Form 2586, *Unescorted Entry Authorization* certificate, for Airfield Management approval prior to receiving a controlled area badge (AF Form 1199)

10.1.4. All visitors/contractors required to operate a vehicle on the airfield must obtain prior permission from Airfield Management before accessing the airfield. Individuals without a current AF Form 1199 will be escorted by individual(s) with proper credentials or must have an EAL signed by the 88 OSS/CC or designated representative and authenticated by SFS.

10.1.4.1. EALs will contain: name (last, first, middle initial), state driver's license number, rank, duty title, phone number, office symbol and clearance (if applicable)

10.1.5. All personnel utilizing a privately owned vehicle (POV) on the airfield must obtain a POV pass from AMOPS. Permanent base assigned contractor vehicles (i.e., Fuels, AGE, Transient Alert, etc.) do not require a POV pass when marked with an organizational/company decal or other type of designation marking.

10.1.6. POV passes are issued in Bldg 206, Room 105. Individual must provide AMOPS with the following:

10.1.6.1. Name

10.1.6.2. Phone Number

10.1.6.3. Vehicle make, model, year, color and license plate.

10.1.6.4. Area of operation/location

10.1.7. POV passes are a controlled item and shall only be displayed while on the airfield. In the event a POV pass is lost or stolen, individuals will immediately notify AMOPS. AMOPS will contact the Base Defense Operations Center to report a lost/stolen POV pass with the associated number.

10.1.8. All temporary POV passes must be turned in to AMOPS at the end of each duty day. Requests for exception to this requirement will be approved by the AFM or DAFM

10.1.9. Permanent POV passes grant access to the airfield for permanently assigned personnel, however, each pass will expire on 31 Dec of the year issued and be re-validated/renewed annually.

CHRISTOPHER B. MEEKER, Colonel, USAF
Commander

Attachment 1**GLOSSARY OF REFERENCES AND SUPPORTING INFORMATION*****References***

445th AW and 88 ABW LOA, *C-17A Portable Night Vision Goggle (NVG) Lighting Concept of Operations (CONOPS)*

National Air and Space Intelligence Center (NASIC)/GXXKX and 88 OSS LOA, *Alternate Airfield Management Operations (AM Ops) Facility*

88 ABW and 180th FW, *Toledo Air National Guard, Hydrazine Response Team (HRT) Procedures* (Anticipated)

88 ABW and 445th AW LOA, *Tactical Arrival/Departure (TAD) Procedures*

88 ABW and NMUSAF LOA, *Wright Field Operations*

AFI 10-1001, *Civil Aircraft Landing Permits*, 23 August 2018

AFI 10-2501, *Emergency Management Program*, 10 Mar 2020

AFI 11-2C-17V3, *C-17 Operations Procedures*, 30 Jul 2019

AFI 11-255V3, *Flight Manager Responsibilities and Procedures*, 24 July 2018

AFMAN 13-204V1, *Management of Airfield Operations*, 22 Jul 2020

AFMAN 13-204V2, *Airfield Management*, 22 Jul 2020

AFMAN 13-204V3, *Air Traffic Control*, 22 Jul 2020

AFI 13-207-O, *Preventing and Resisting Aircraft Piracy (Hijacking) (FOUO)*, 5 February 2019

AFI 31-101, *Integrated Defense (ID) (FOUO)*, 25 Mar 2020

AFI 32-1043, *Managing, Operating, and Maintaining Aircraft Arresting Systems*, 4 March 2015

AFI 91-202, *The US Air Force Mishap Prevention Program*, 12 Mar 2020

AFI 91-212, *Bird/Wildlife Aircraft Strike Hazard (BASH) Management Program*, 31 May 2018

AFMAN 11-213, *Military Flight Plan and Flight Movement Data Communications*, 27 April 2018

AFMAN 33-363, *Management of Records*, 1 March 2008

AFPAM 32-2004, *Aircraft Fire Protection for Exercises and Contingency Response Operations*, 21 April 2010

AFPD 13-2, *Air Traffic, Airfield, Airspace and Range Management*, 3 Jan 2019

Air Force Research Laboratory and 88 ABW, *Small UAS (SUAS) Operations within Wright-Patterson AFB Class D Airspace*

Certificate of Waiver or *Authorization (COA) 2011-CSA-4-MOA*

DESR 6055.09 AFMAN 91-201, *Explosives Safety Standards*, 20 May 2020

JO 7110.65, *Air Traffic Control*, 20 June 2019

OSAM OI 13-201, *Airfield Management*, March 2019

UFC 3-260-04, *Airfield and Heliport Marking*, 16 May 2018

WPAFB *Comprehensive Emergency Management Plan (CEMP)* 10-2

WPAFB *Preventing and Resisting Aircraft Piracy (Hijacking) Procedures*

WPAFBI 13-213, *Airfield Driving*, 26 February 2016

WPAFBI 15-101, *Weather Support*, 19 May 2017

WPAFB *Bird/Aircraft Strike Hazard (BASH) Plan*

WPAFB *sUAS Policy Letter*

WPAFB *Snow and Ice Plan*

Adopted Forms

AF Form 1199, *Air Force Entry Control Card (Accountable) (Used with Advanced Automated Entry Control System)*, 1 November 1986

AF Form 3616, *Daily Record of Facility Operation*, 31 Aug 2018

AF Form 847, *Recommendation for Change of Publication*, 22 September 2009

DD Form 1801, *DoD International Flight Plan*, 1 May 1987

Abbreviations and Acronyms

AAS—Aircraft Arresting System

ACCTLR—Assistant Chief Controller

ABS—Anti-Lock Braking System

ADI—Airfield Driving Instruction

ADPM—Airfield Driving Program Manager

AF—Air Force

AFCEC—Air Force Civil Engineering Center

AFSA—Air Force Flight Standards Agency

AFH—Air Force Handbook

AFI—Air Force Instruction

AFJI—Air Force Joint Instruction

AFJMAN—Air Force Joint Manual

AFM—Airfield Manager

AFMAN—Air Force Manual

AFJQS—Air Force Job Qualification Standard

AFPAM—Air Force Pamphlet

AFPD—Air Force Policy Directive
AFRC—Air Force Reserve Command
AFREP—Air Force Representative
AFSC—Air Force Specialty Code
AGE—Aerospace Ground Equipment
AICUZ—Air Installation Compatible Use Zone
AIM—Aeronautical Information Manual
AIREVAC—Aeromedical Evacuation
AIS—Automatic Identification System
AFRIMS—Air Force Records Information Management System
AM—Airfield Management
AMA—Academy of Model Aeronautics
AMOC—Airfield Management Operations Coordinator
AMOM—Airfield Management Operations Manager (Civilian Only)
AMOPS—Airfield Management Operations
AMOS—Airfield Management Operations Supervisor
AMSL—Airfield Management Shift Lead
AMTM—Airfield Management Training Manager (Civilians Only)
ANG—Air National Guard
AMOPS—Airfield Operations
AOB—Airfield Operations Board
AOF—Airfield Operations Flight
AOF/CC—Airfield Operations Flight Commander
ARFF—Aircraft Rescue and Fire Fighting
ARTCC—Air Route Traffic Control Center
ASR—Airport Surveillance Radar
ASRR—Airfield Suitability and Restrictions Report
ATARS—Air Traffic Activity Reporting System
ATC—Air Traffic Control
ATCS—Air Traffic Control Specialist
ATCAL—Air Traffic Control and Landing Systems
ATCT—Air Traffic Control Tower

ATCTS—Air Traffic Control Training Series
ATIS—Automatic Terminal Information Service
ATSN—Assistant NCOIC, ATC Training and Standardization
BAS—Basic Allowance for Subsistence
BASH—Bird/Wildlife Aircraft Strike Hazard
BHWG—Bird Hazard Working Group
BLOS—Beyond Line of Sight
BWC—Bird Watch Condition
CAT—Category
CBMS—Capabilities-Based Manpower Standard
CBT—Computer Based Training
CBRNE—Chemical, Biological, Radiological, Nuclear and high-yield Explosives
CCTLR—Chief Controller
CD (-R)—Compact Disc (-Recordable)
CDR—Continuous Data Recording
CE—Civil Engineering
CEMP—Comprehensive Emergency Management Plan
CFETP—Career Field Education and Training Plan
CFM—Career Field Manager
CFR—Code of Federal Regulations
CMA—Controlled Movement Area
CMAV—Controlled Movement Area Violation
CMS—Case Management System
COA—Certificate of Authorization
COMSEC—Communications Security
CP—Command Post
CPD—Core Personnel Document
CPF—Civilian Personnel Flight
CRM—Crew Resource Management
CTO—Control Tower Operator
CTRD—Certified Tower Radar Display
CWW—Cooperative Weather Watch

DAAS—DoD Advanced Automation System (also known as STARS)

DAFM—Deputy Airfield Manager

DALR—Digital Audio Legal Recorder

DAT—Digital Audio Tape

DBRITE—Digital Bright Radar Indicator Tower Equipment

DD Form—Department of Defense Form

DH—Decision Height

DLT—Digital Linear Tapes

DNIC—Duties Not to Include Controlling

DoD—Department of Defense

DoT—Department of Transportation

DSM—Diagnostic and Statistical Manual

DSN—Defense Switched Network

DTAS—Digital Terminal Automation Systems

DTM—Digital Terrain Maps

DV—Distinguished Visitor

DVA—Diverse Vector Area

DVD(-R)—Digital Video Disc (-Recordable)

DVRS—Digital Voice Recorder System

EDIT—Experiencing Difficulty In Training

EMI—Electromagnetic Interference

EOC—Emergency Operations Center

EO/IR—Electro-Optical Infrared

ETL—Engineering Technical Letter

ETVS—Enhanced Terminal Voice Switch

FAA—Federal Aviation Administration

FAAO—Federal Aviation Administration Order

FAF—Final Approach Fix

FCF—Functional Check Flight

FCG—Foreign Clearance Guide

FCT—Facility Continuation Training

FD—Fire Department

FDS—Flight Data System
FLIP—Flight Information Publication
FLT—Front Load Training
FOD—Foreign Object Damage
FOIA—Freedom of Information Act
FOUO—For Official Use Only
FSS—Flight Service Station
FWG—Facility Working Group
GC—Ground Control
GE—Ground Emergency
GPS—Global Positioning System
HATR—Hazardous Air Traffic Report
HIRL—High Intensity Runway Lights
HQ AFFSA—Headquarters Air Force Flight Standards Agency
IAW—In Accordance With
IC—Incident Commander
ICAO—International Civil Aviation Organization
IDS5—Information Display Systems
IFE—In-Flight Emergency
IFR—Instrument Flight Rules
IMC—Instrument Meteorological Conditions
ILS—Instrument Landing System
INST—Instrument or Instrument Hold Line
IR—Ice on Runway
JO—Joint Order
KSA—Knowledge, Skills and Abilities
LAAS—Low Altitude Alert System
LAN—Local Area Network
LDA—Localizer Directional Aid
LMR—Land Mobile Radio
LOA—Letter of Agreement
LOI—Local Operating Instruction

LOP—Local Operating Procedure
LOS—Line of Sight
LSR—Loose Snow on Runway
MAJCOM—Major Command
MARE—Major Accident Response Exercise
MCOe—Military Customs Officer Exempted
MDS—Mission Design Series
MGRS—Military Grid Reference System
MIA—Minimum IFR Altitude
MLS—Microwave Landing System
MM—Middle Marker
MOU—Memorandum of Understanding
MRI—Master Reference Index
MSAW—Minimum Safe Altitude Warning
MTI—Moving Target Indicator
MTL—Master Task Listing
MTP—Master Training Plan
MTTR—Master Task and Technical Reference
MVA—Minimum Vectoring Altitude
NAF—Numbered Air Force
NAMO—NCOIC, Airfield Management Operations
NAS—National Airspace System
NATCT—NCOIC, Air Traffic Control Training
NAVAID—Navigational Aid
NLT—No Later Than
NM—Nautical Mile
NORDO—No Radio
NOTAM—Notice to Air Missions
NSE—NCOIC, ATC Standardization and Evaluation
OBO—Official Business Only
OCL—Operational Capability Level
OI—Operating Instruction

OJT—On the-Job Training
OPLAN—Operations Plan
OPR—Office of Primary Responsibility
ORE—Operational Readiness Exercise
ORI—Operational Readiness Inspection
ORM—Operational Risk Management
OSS—Operations Support Squadron
PAPI—Precision Approach Path Indicator
PAR—Precision Approach Radar
PCA—Permanent Change of Assignment
PCAS—Primary Crash Alarm System
PCS—Permanent Change of Station
PCG—Position Certification Guide
PHA—Preventive Health Assessment
POFZ—Precision Obstacle Free Zone
POV—Privately Owned Vehicle
PM—Preventive Maintenance
PMI—Preventative Maintenance Inspection
PPR—Prior Permission Required
PSR—Packed Snow on Runway
PTD—Pilot to Dispatch
PWS—Performance Work Statement
QA—Quality Assurance
QRC—Quick Reaction Checklist
QTP—Qualification Training Package
RAC—Risk Assessment Code
RAPCON—Radar Approach Control
RAWS—Radar, Airfield & Weather Systems
RCR—Runway Condition Reading
RCS—Runway Control Structure
RDS—Records Disposition Schedule
RFC—Radar Final Control

RIF—Recent Information File
RMP—Radar Monitoring Position
RPI—Runway Point of Intercept
RRF—Ready Reference File
RSC—Runway Surface Condition
RSI—Remote Status Indicator
RSRS—Reduced Same Runway Separation
RVR—Runway Visual Range
RWY—Runway
SAR—Synthetic Aperture Radar
SATCOM—Satellite Communications
SAV—Staff Assistance Visit
SC—Senior Controller
SCN—Secondary Crash Net
SCPD—Standard Core Personnel Document
SDF—Simplified Directional Facility
SE—Safety
SEI—Specialty Experience Identifier
SF—Security Forces
SIGINT—Signals Intelligence
SIGNAL—Simulation and Integration of Ground, Network, and Air Links
SII—Special Interest Item
SLR—Slush on Runway
SM—Statute Mile
SMS—Safety Management System
SOF—Supervisor of Flying
STAR—Standard Arrival Route
STARS—Standard Terminal Automation Replacement System
STS—Specialty Training Standard
SUA—Special Use Airspace
sUAS—small Unmanned Aircraft System
SUI—Sensitive Unclassified Information

TACAN—Tactical Air Navigation
TCAS—Traffic Alert and Collision Avoidance System
TCW—Tower Controller Workstation
TDW—Tower Display Workstation
TDY—Temporary Duty
TERPS—Terminal Instrument Procedures
TO—Technical Order
TOI—Training Operating Instruction
TR—Technical Reference
TRB—Training Review Board
TSC—Training Status Codes
TSN—NCOIC, ATC Training and Standardization
TSS—Tower Simulation System
UA—Unmanned Aircraft
UAS—Unmanned Aircraft System
UGT—Upgrade Training
UHF—Ultra High Frequency
UMD—Unit Manning Document
UPS—Uninterruptible Power Supply
US—United States
USAF—United States Air Force
USAFR—United States Air Force Reserve
USNO—United States Naval Observatory
UTC—Unit Type Code
UTC—Universal Time Coordinated
UTG—Upgrade Training Guide
UTM—Unit Training Manager
VCO—Vehicle Control Officer
VCNCO—Vehicle Control Noncommissioned Officer
VFR—Visual Flight Rules
VMC—Visual Meteorological Conditions
VHF—Very High Frequency

WR—Wet Runway

WS—Watch Supervisor

XP—Plans

Attachment 2

WRIGHT FIELD AIRFIELD DIAGRAM

Figure A2.1. Wright Field Airfield Diagram.



Attachment 3

PATTERSON FIELD AIRFIELD DIAGRAM

Figure A3.1. Patterson Field Airfield Diagram.

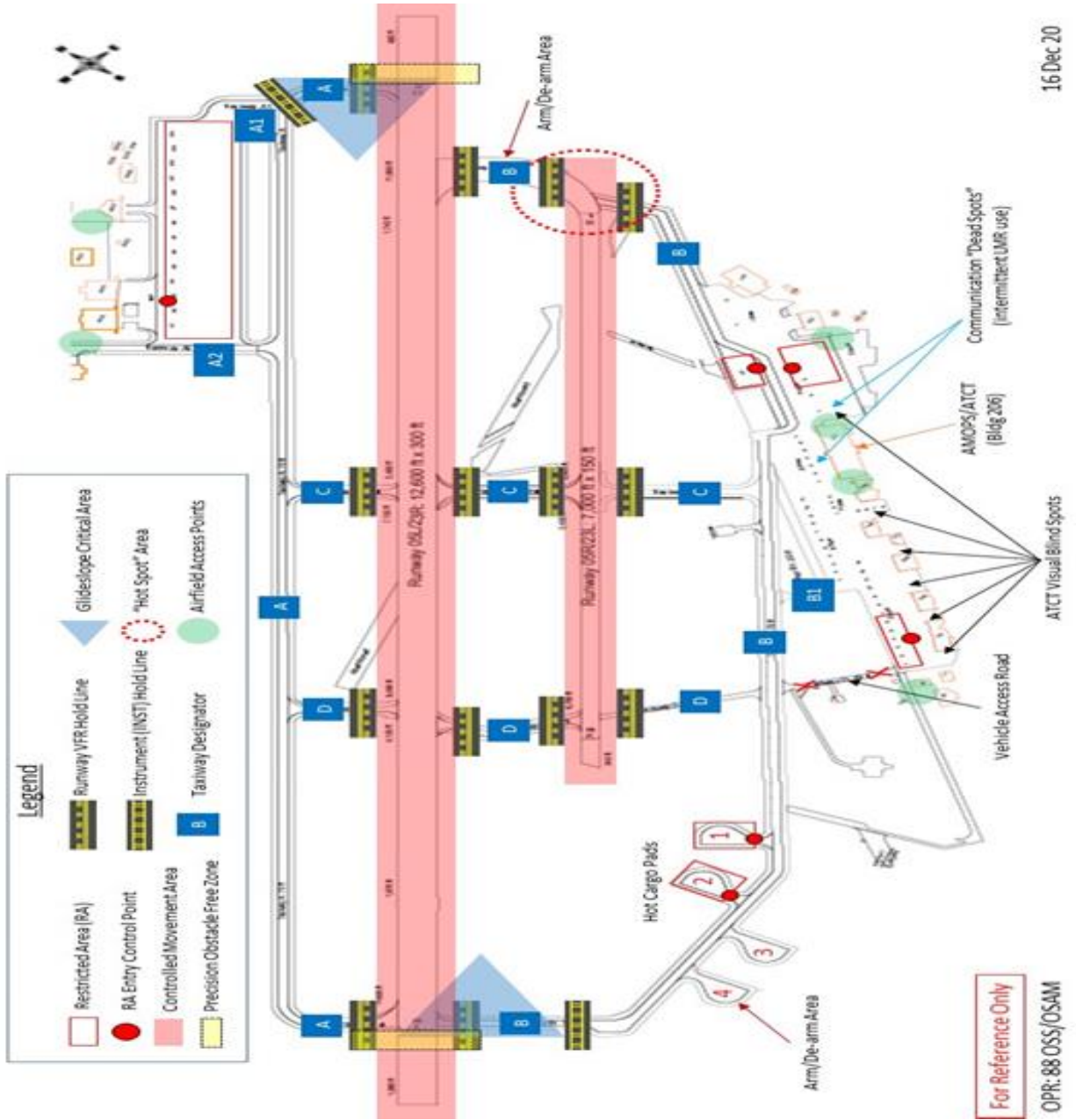

Attachment 4

PATTERSON FIELD EAST RAMP PARKING PLAN

Figure A4.1. East Ramp Parking Plan Diagram.



Attachment 5

PATTERSON FIELD WEST RAMP PARKING PLAN

Figure A5.1. West Ramp Parking Plan Diagram.

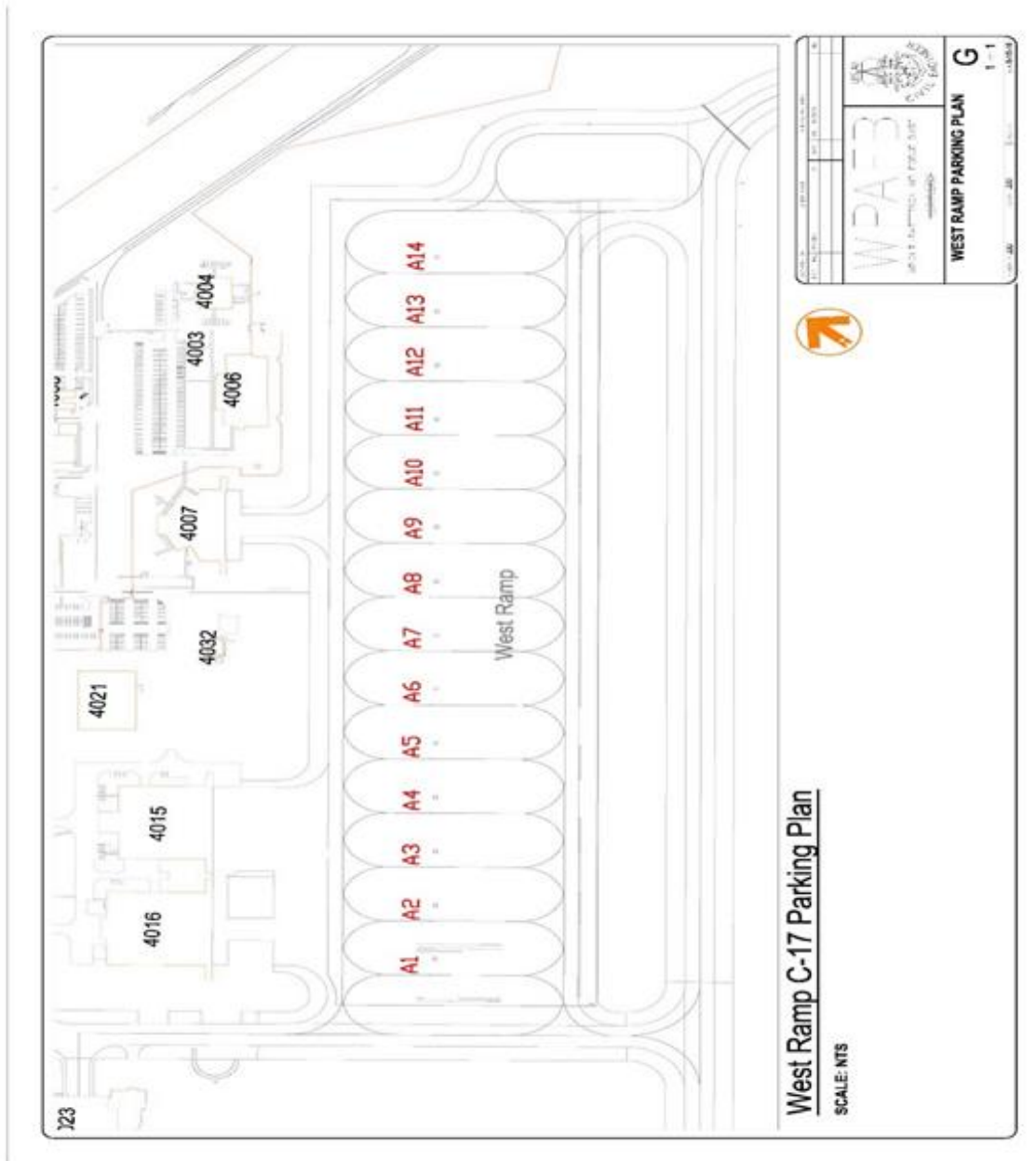

Attachment 6

PATTERSON FIELD RUNWAY 05L/23R PRECISION OBSTACLE FREE ZONE (POFZ) AND LOCALIZER CRITICAL AREA

Figure A6.1. POFZ RWY 23R Approach End.

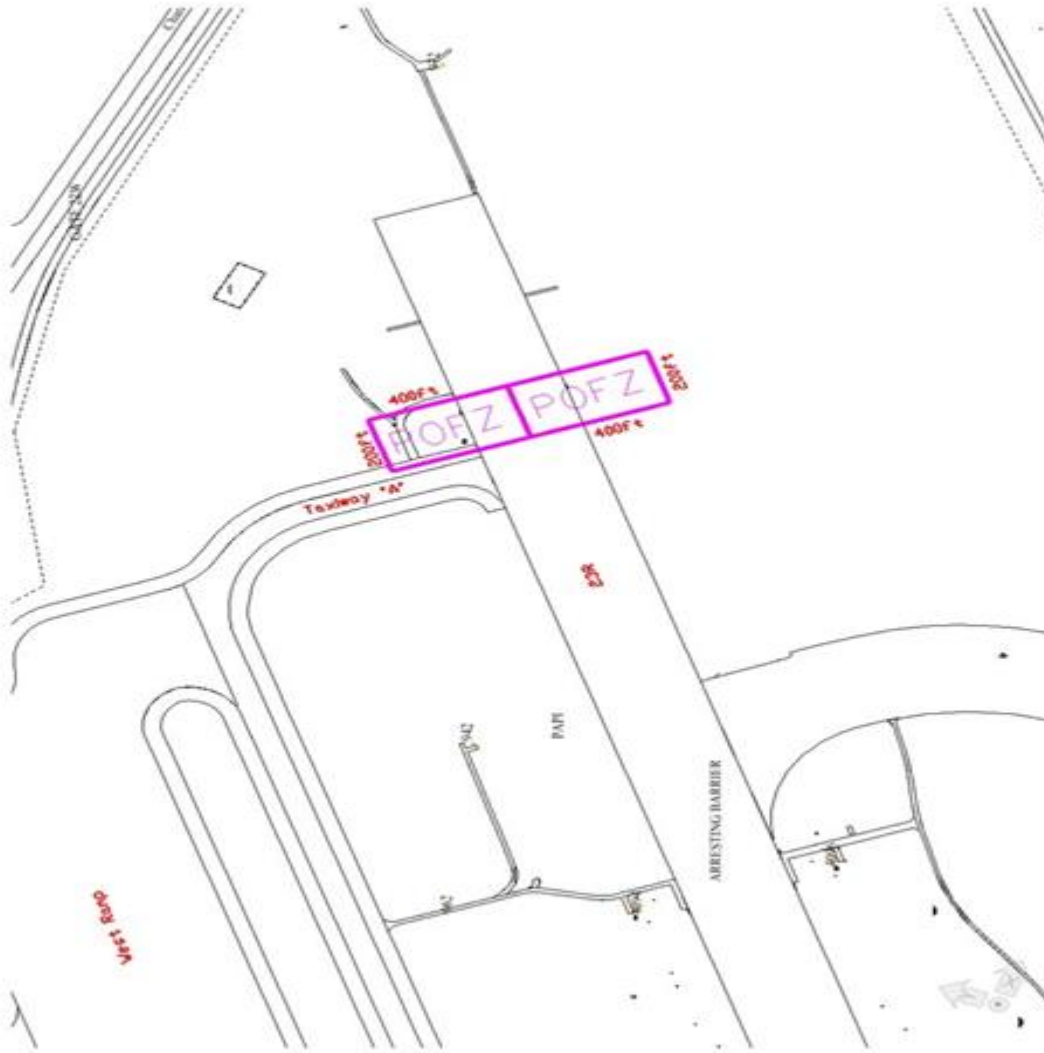
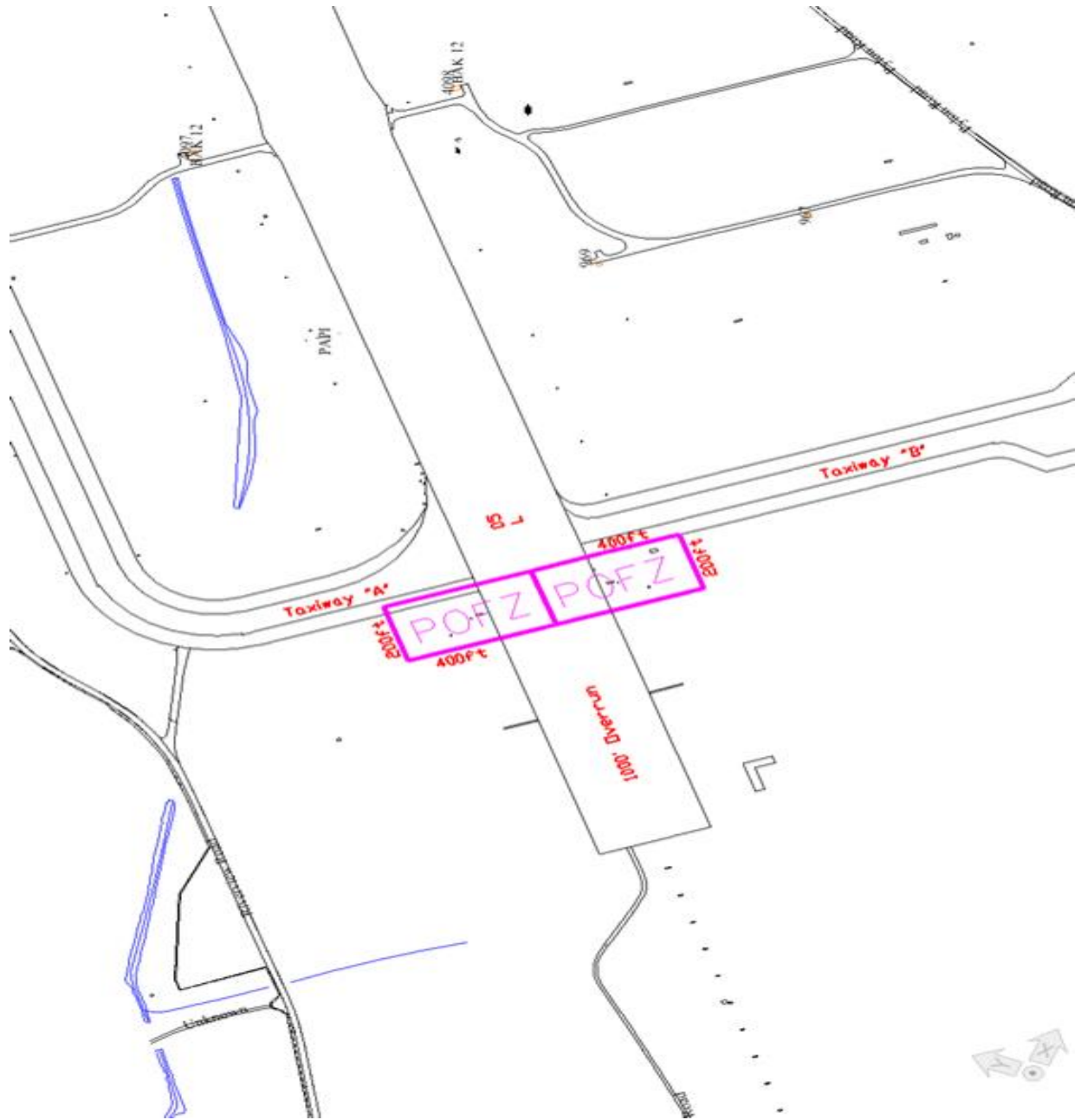

Figure A6.2. POFZ RWY 05L Approach End Diagram.



Attachment 7

PATTERSON FIELD CONTROLLED MOVEMENT AREA/ RESTRICTED AREA

Figure A7.1. CMA/Restricted Area Diagram.

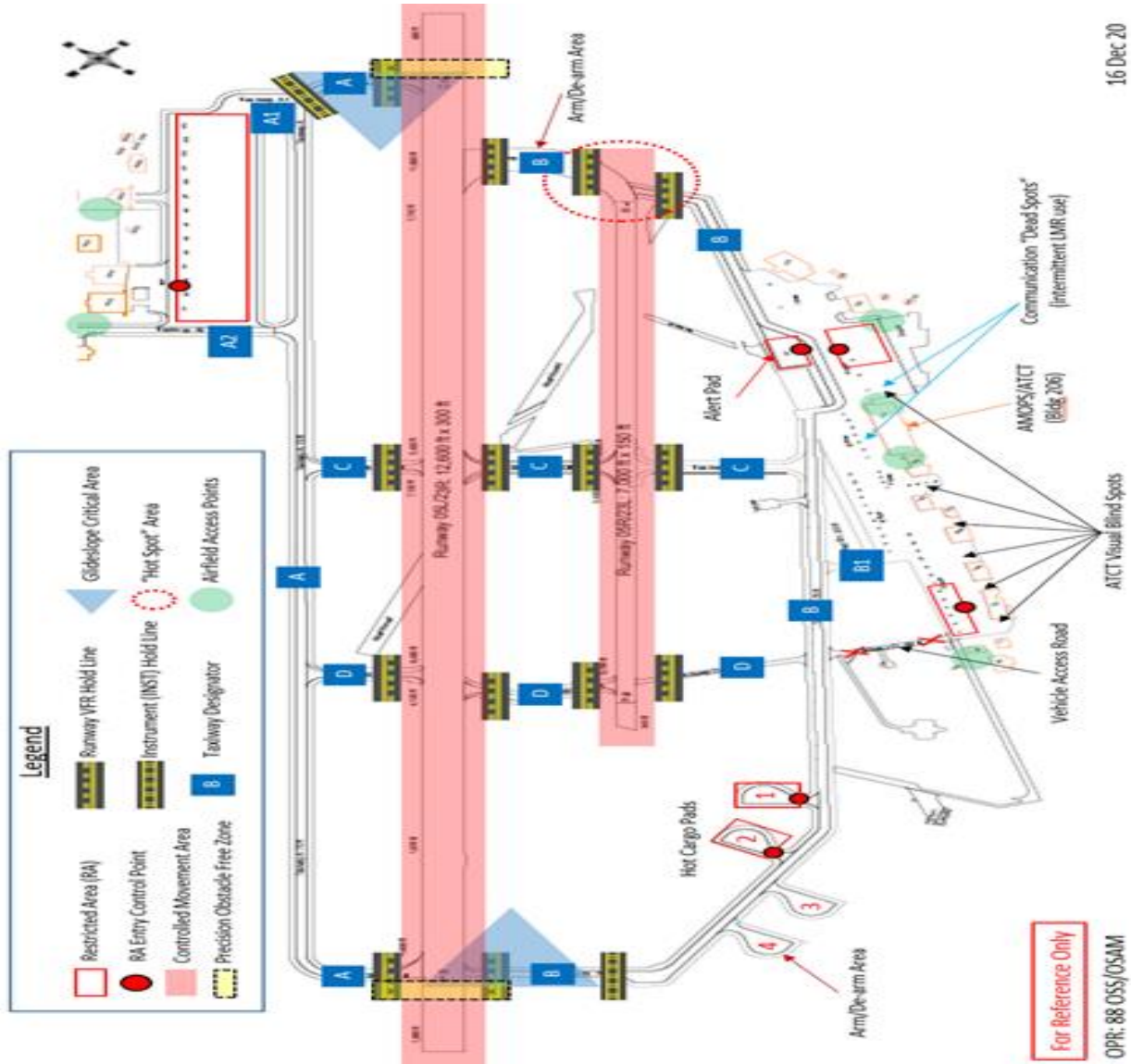

Attachment 8

PATTERSON FIELD AIRFIELD SPECIAL OPERATIONS AREAS/RAMPS

Figure A8.1. Airfield Special Operations Areas/Ramps Diagram.

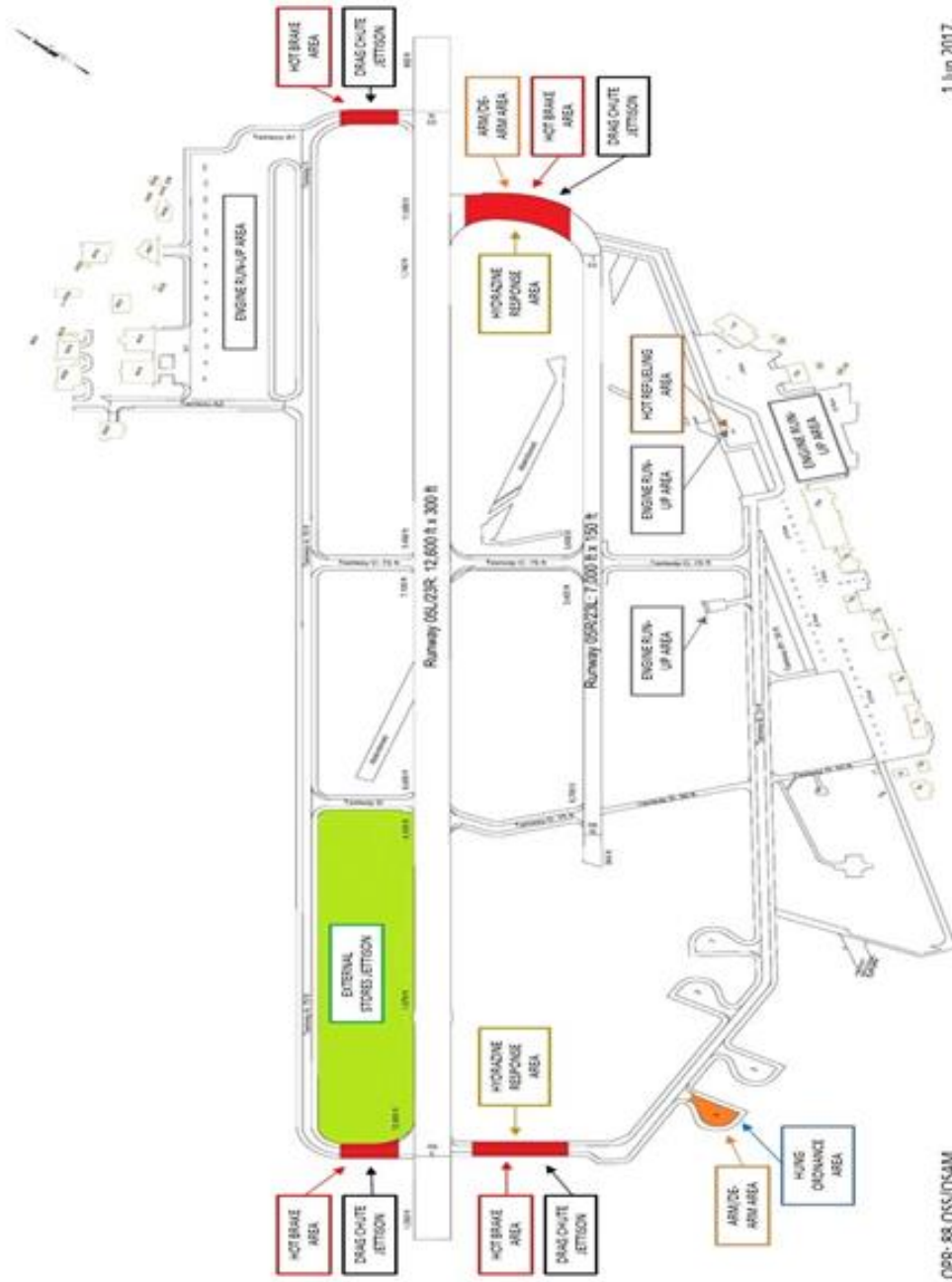

Attachment 9
FLYING AREAS

Figure A9.1. Flying Areas Airspace Diagram.

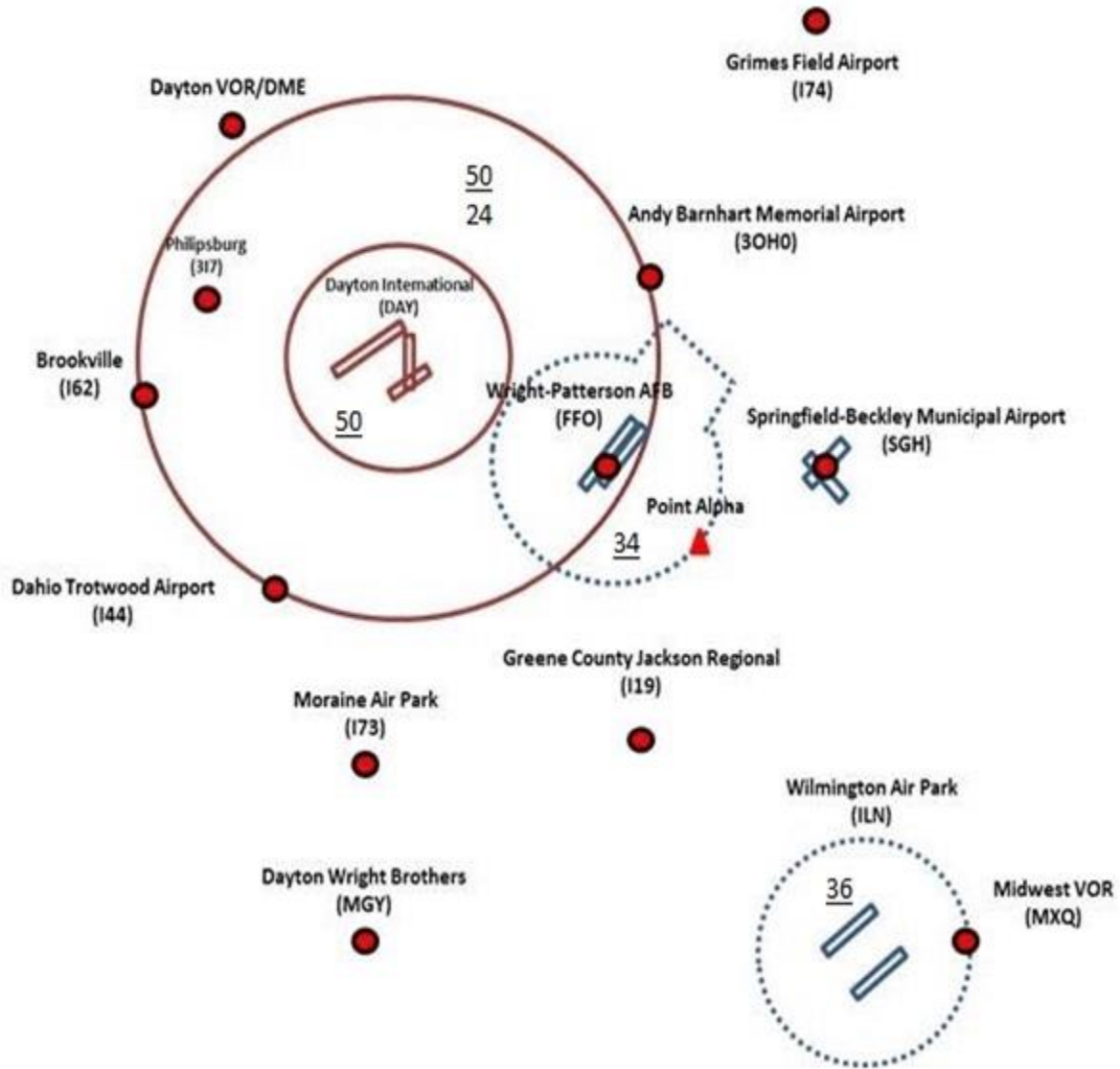

Attachment 10

VFR TRAFFIC PATTERNS

Figure A10.1. VFR Traffic Patterns Diagram.

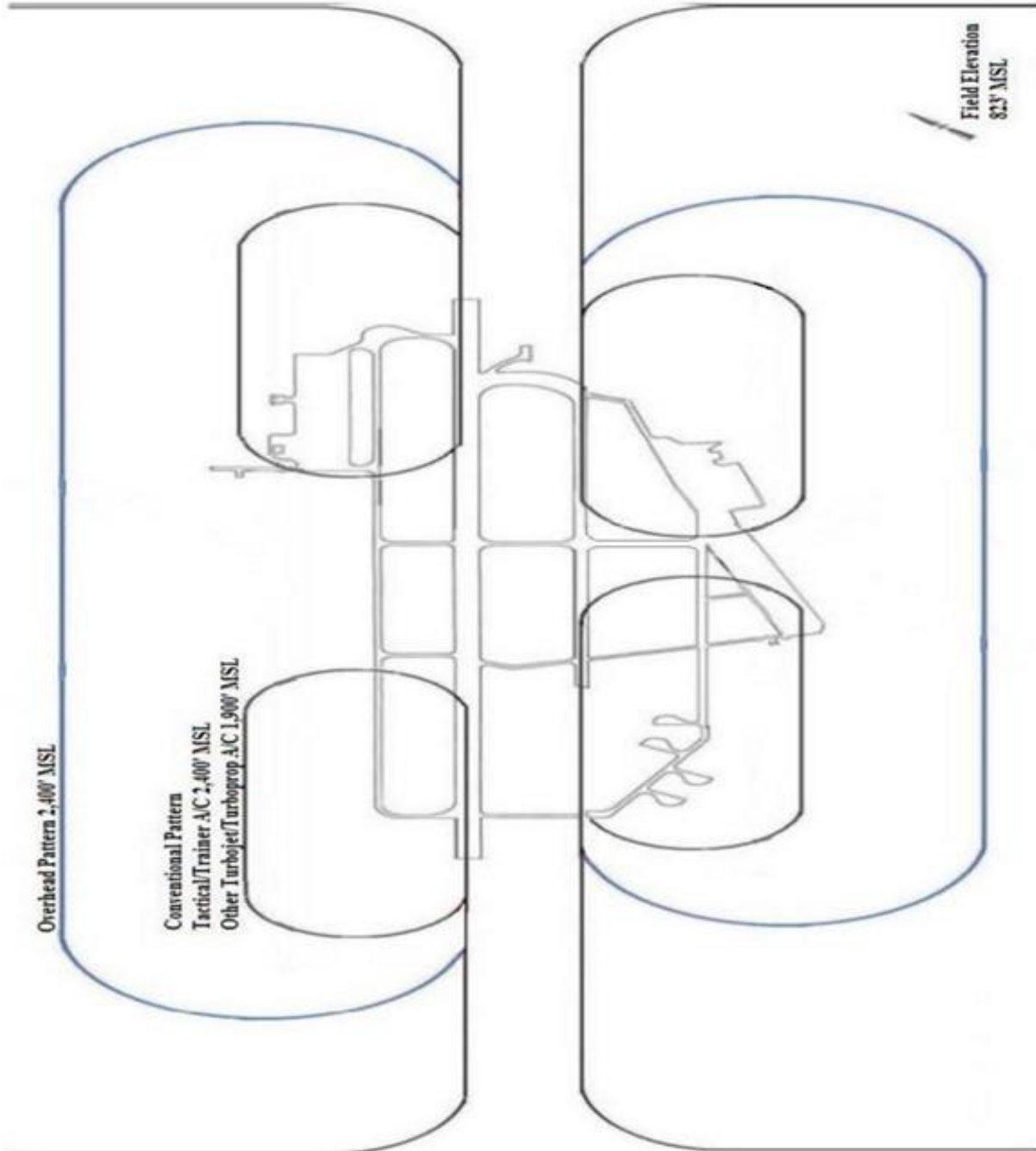

Attachment 11

STRAIGHT IN SIMULATED FLAME-OUT (SI-SFO)

Figure A11.1. SI-SFO.

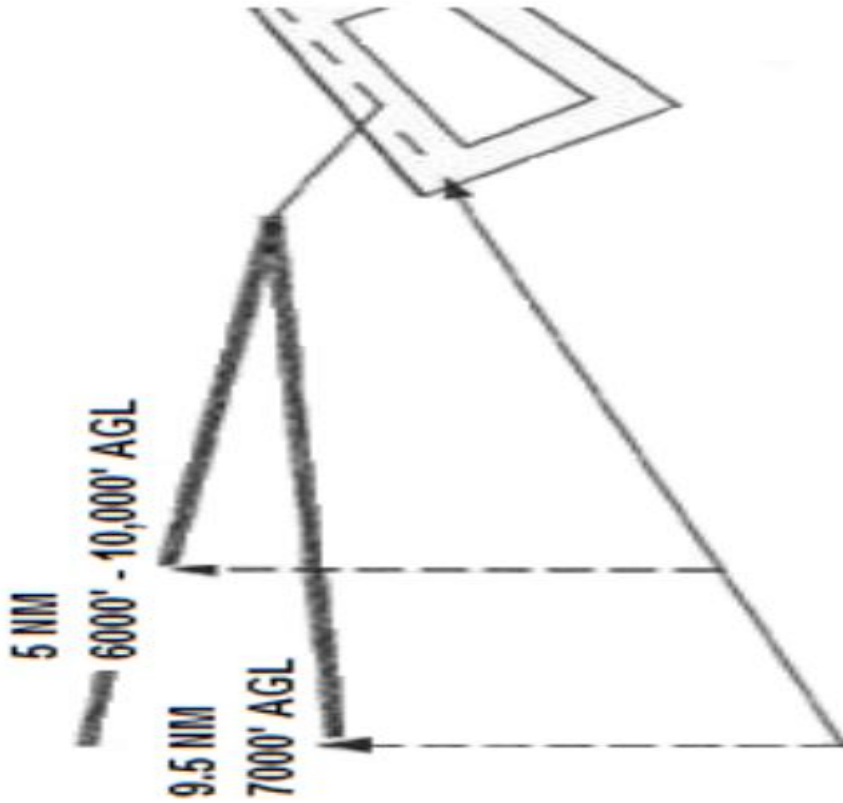

Attachment 12

OVERHEAD SIMULATED FLAME OUT (SFO)

Figure A12.1. Overhead SFO.

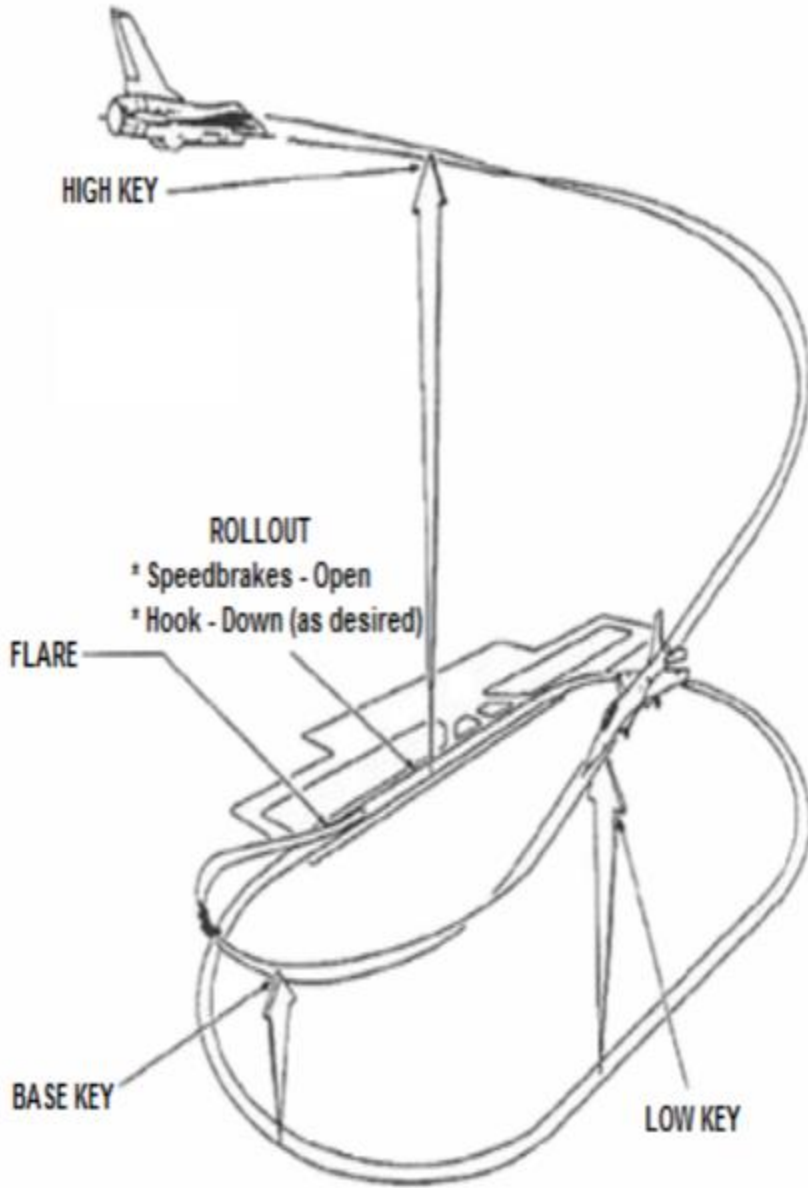

Attachment 13

445 AW GROUND OPERATIONS

Figure A13.1. 445 AW Ground Operations Diagram.

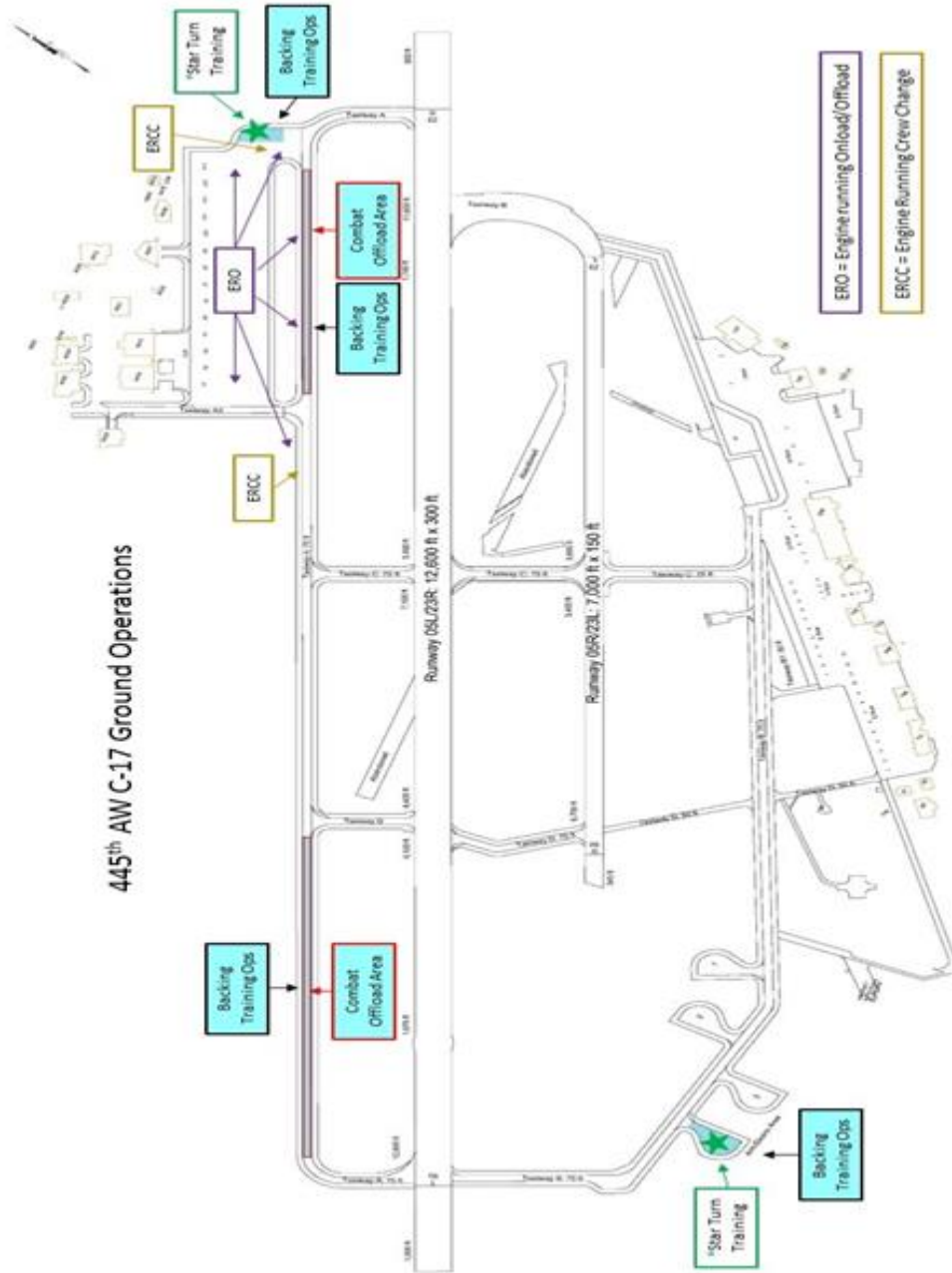

2 Jun 2017

OPR: 88 OSS/OSAM

Attachment 14

PATTERSON DROP ZONE

Figure A14.1. Patterson Drop Zone.



Attachment 15
AIRFIELD SWEEPING PLAN

Figure A15.1. Sweeping Diagram.

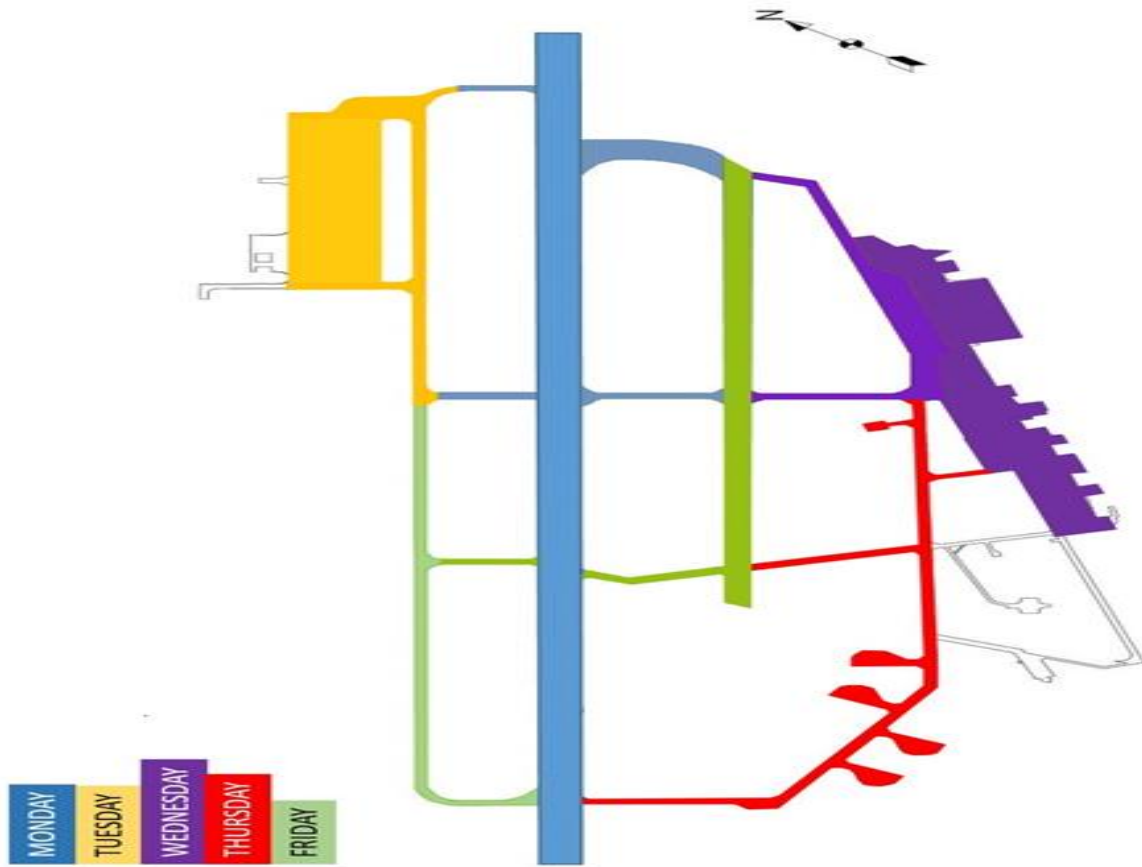

Attachment 16

RAMS CLUB FLYING FIELD – WRIGHT FIELD (AREA B)

Figure A16.1. Rams Club Flying Field – Wright Field (Area B).

