

**BY ORDER OF THE  
SECRETARY OF THE AIR FORCE**



**AIR FORCE MANUAL 32-1065  
17 JULY 2020**

**UNITED STATES AIR FORCES IN  
EUROPE-AIR FORCES AFRICA  
Supplement**

**24 FEBRUARY 2022  
Certified Current, 5 SEPTEMBER 2025**

**CIVIL ENGINEERING**

**GROUNDING & ELECTRICAL  
SYSTEMS**

**COMPLIANCE WITH THIS PUBLICATION IS MANDATORY**

---

**ACCESSIBILITY:** Publications and forms are available for downloading or ordering on the e-Publishing website at [www.e-Publishing.af.mi](http://www.e-Publishing.af.mi).

**RELEASABILITY:** There are no releasability restrictions on this publication.

---

OPR: AF/A4CF

Certified by: SAF/IE  
(Mr. John W. Henderson)

Supersedes: AFI 32-1064, 29 December 2016  
AFI 32-1065, 14 June 2017  
AFMAN 32-1083, 30 Nov 1995

Pages: 105

**(USAFE-AFAFRICA)**

OPR: USAF/AFIMSC DET4/CEO

Certified by: HQ USAFE-  
AFAFRICA/A4C  
(Col Scott B. Matthews)

Supersedes: AFI 32-1065\_USAFESUP\_I, 25 August 2015

Pages: 105

---

This Air Force Manual (AFMAN) implements Air Force Policy Directive (AFPD) 32-10, *Installations and Facilities*. It assigns responsibilities and requirements for electrical grounding systems, including systems for equipment grounding, lightning protection, and static protection. This AFMAN also implements the maintenance requirements of Department of Defense DoDM 6055.09, Volume 2, *Ammunition Explosives Safety Standards*, Enclosure 4, "Lightning Protection," for potentially hazardous explosives facilities. This AFMAN applies to Regular Air Force (RegAF), Air Force Reserve Command (AFRC) and Air National Guard (ANG) military and civilian personnel performing work or inspections in accordance with this AFMAN. This publication may be supplemented at any level, but all supplements must be routed to the Office of

Primary Responsibility (OPR) listed above for coordination prior to certification and approval. Refer recommended changes and questions about this publication to the OPR listed above using the Air Force Form 847, *Recommendation for Change of Publication*; route AF Forms 847 from the field through the appropriate chain of command. The authorities to waive wing/unit level requirements in this publication are identified with a Tier (“T-0, T-1, T-2, T-3”) number following the compliance statement. See Air Force Instruction (AFI) 33-360, *Publications and Forms Management*, **Table 1.1** for a description of the authorities associated with the Tier numbers. Submit requests for waivers through the chain of command to the appropriate Tier waiver approval authority, or alternately, to the Publication OPR for non-tiered compliance items. Ensure all records created as a result of processes prescribed in this publication are maintained in accordance with Air Force Manual (AFMAN) 33-363, *Management of Records*, and disposed of in accordance with the Air Force Records Disposition Schedule located in the Air Force Records Information Management System. The use of the name or mark of any specific manufacturer, commercial product, commodity, or service in this publication does not imply endorsement by the Air Force.

**(USAFE-AFAFRICA)** This publication supplements AFMAN 32-1065, *Grounding & Electrical Systems*. This supplement defines the responsibilities and procedures for Grounding and Lightning Protection Systems in United State Air Forces in Europe-Air Forces AFAFRICA (USAFE-AFAFRICA). This supplement applies to all United State Air Forces in Europe-Air Forces AFAFRICA (USAFE-AFAFRICA) Regular Air Force. It does not apply to Air Force Reserve (AFRC), United States Space Force (USSF), or Air National Guard (ANG) units. Lightning protection systems installed at Munitions Support Squadrons (MUNSS) sites shall comply with host nation lightning protection system codes and standards, and applicable portions of this supplement. Ensure that all records created as a result of processes prescribed in this publication are maintained in accordance with (IAW) AFI 33-322, *Records Management and Information Governance Program*, and disposed of IAW Air Force Records Information Management System (AFRIMS) Records Disposition Schedule (RDS). Refer recommended changes and questions about this publication to the Office of Primary Responsibility (OPR) using the AF Form 847, *Recommendation for Change of Publication*. The authorities to waive wing, and unit level requirements in this publication are identified with a tier number (“T-0, T-1, T-2, T-3”) following the compliance statement. See Department of the Air Force Instruction (DAFI) 33-360, *Publications and Forms Management*, for a description of the authorities associated with the Tier numbers. Submit requests for waivers through the chain of command to the appropriate tier waiver approval authority, utilizing guidance identified in DAFI 33-360. This publication may be supplemented at any level, but all supplements must be routed to the OPR of this publication for coordination prior to certification and approval. Compliance with the attachments in this publication is mandatory.

### ***SUMMARY OF CHANGES***

This AFMAN has been substantially revised and must be completely reviewed. Major changes include the addition of electrical safe practices, updated office symbols, updated glossary, and updated references.

**(USAFE-AFAFRICA)** Update is required to incorporate the latest guidance with new AFMAN 32-1065, 17 July 2020.

<b>Chapter 1—Roles and Responsibilities</b>	<b>7</b>
Section 1A—Maintenance	7
1.1. The Assistant Secretary of the Air Force Installations, Environment, and Energy (SAF/IE) shall: .....	7
1.2. The Headquarters, United States Air Force, Deputy Chief of Staff for Logistics, Engineering and Force protection, Directorate of Civil Engineers (AF/A4C) shall:.....	7
1.3. The Air Force Installation and Mission Support Center (AFIMSC) shall: .....	7
1.4. The Air Force Civil Engineer Center (AFCEC) shall:.....	7
1.5. The Base Civil Engineer (BCE) shall: .....	8
1.6. (Added-USAFE-AFAFRICA) The Munition Support Squadron (MUNSS) shall: .	9
<b>Chapter 2—Recordkeeping and Review for Explosives Facilities.</b>	<b>11</b>
2.1. Inspectors and testers. ....	11
2.2. The Base Civil Engineer (BCE). ....	11
2.3. Inspectors and testers. ....	11
2.4. Mandatory Review and Update of Record Drawings for Nuclear-Capable Weapons and Munitions Storage and Maintenance Facilities. ....	11
2.5. Active and ongoing projects. ....	12
2.6. Contract for a lightning protection system project.....	12
<b>Chapter 3—FORMS</b>	<b>13</b>
3.1. Forms for inspectors and testers. ....	13
<b>Chapter 4—PERSONNEL QUALIFICATIONS.</b>	<b>14</b>
4.1. General Qualifications. ....	14
4.2. Advanced Qualifications.....	14
4.3. Project Acceptance Qualifications.....	15
4.4. IG and Nuclear Surety. ....	15
<b>Chapter 5—DEVELOPING PROCEDURES</b>	<b>16</b>
5.1. Standard and procedures. ....	16
<b>Chapter 6—TESTING REQUIREMENTS</b>	<b>17</b>
Section 6A—Grounding Resistance and Continuity Tests and Visual Inspections	17
6.1. Testing Requirements. ....	17

<b>Chapter 7—VISUAL INSPECTIONS OF LIGHTNING PROTECTION SYSTEMS</b>	<b>18</b>
7.1. Inspections.....	18
<b>Chapter 8—VISUAL INSPECTION OF FACILITY GROUNDS</b>	<b>19</b>
Section 8A—Grounding and Lightning Protection Requirements	19
8.1. Visual Inspection.....	19
<b>Chapter 9—INTRODUCTION</b>	<b>20</b>
Section 9A—Grounding and Lightning Protection Requirements	20
9.1. Grounding and lightning protection requirements.....	20
<b>Chapter 10—TESTING AND INSPECTING STATIC AND LIGHTNING PROTECTION SYSTEMS AND GROUNDING</b>	<b>21</b>
10.1. Procedures.....	21
10.2. Inspection and Testing.....	21
10.3. Records.....	21
Figure 10.1. Example Sketch of Test Points (Typical). ....	22
10.4. (Added-USAFE-AFAFRICA) USAFE Testing.....	22
<b>Chapter 11—Static Protection</b>	<b>23</b>
11.1. Static Protection for Electronics and Electrical Equipment.....	23
11.2. Static Bus Bars.....	23
Figure 11.1. Grounding Static Bus Bar on Interior Wall. ....	25
11.3. Belting Requirements.....	25
11.4. Conductive Floor Grounds.....	26
<b>Chapter 12—LIGHTNING PROTECTION SYSTEMS</b>	<b>27</b>
12.1. Lightning protection requirements.....	27
12.2. General.....	27
12.3. Bonding Requirements.....	27
12.4. Resistance to Ground.....	27
12.5. Lightning Protection for Explosives Facilities.....	28
12.6. Explosives Facility with Large Perimeter.....	28
Figure 12.1. ECM With Center Conductor and Air Terminals.....	29
Figure 12.2. ECM Without Center Conductor and Air Terminals.....	30
12.7. Sunshades.....	31

12.8.	Protective Aircraft Shelters (PAS) (also known as Hardened Aircraft Shelter (HAS)).....	31
12.9.	Lightning Protection for Above Ground Launch Structure. ....	31
12.10.	(Added-USAFE-AFAFRICA) Critical Communication Facilities.....	31
<b>Chapter 13—</b>	<b>SURGE PROTECTION</b>	<b>33</b>
13.1.	Surge protection.....	33
13.2.	WSAs, MSAs, and Communications Facilities: .....	33
13.3.	Igloos or ECMs:.....	34
13.4.	Maintenance Facilities: .....	34
13.5.	Communications Facilities: .....	34
13.6.	General Requirements: .....	34
13.7.	User Requirements:.....	34
<b>Chapter 14—</b>	<b>APPLICATION AND SCOPE</b>	<b>35</b>
Section 14A—	Electrical Safe Practices	35
14.1.	Application and Scope.....	35
<b>Chapter 15—</b>	<b>SUPERVISOR RESPONSIBILITIES</b>	<b>36</b>
15.1.	Personal Safety. ....	36
15.2.	Planning and Worker Awareness.....	36
15.3.	Training Assistance.....	36
15.4.	Safety Meetings. ....	36
15.5.	Specific Job-Related Safety Training. ....	37
15.6.	Assigning Tasks.....	38
15.7.	Job Site Inspection. ....	38
15.8.	Mishap Reports.....	38
15.9.	Standards and Codes.....	38
15.10.	Protective Equipment.....	38
15.11.	Scheduling Routine Maintenance. ....	38
15.12.	First Aid Training. ....	38
15.13.	Rescue Training.....	39
15.14.	Noise Hazards.....	39
15.15.	System Maintenance.....	39
15.16.	Technical Data. ....	39
15.17.	Supervisory Control and Data Acquisition (SCADA) Systems.....	39

15.18. Safe Clearance. ....	39
15.19. Work on Energized Equipment.....	40
15.20. Routine Maintenance Outages.....	40
<b>Chapter 16—POLYCHLORINATED BIPHENYLS (PCB)</b>	<b>41</b>
16.1. Purpose and Limitations. ....	41
16.2. Personal Contact Precautions.....	41
16.3. Cleaning Spills.....	41
16.4. Controlling Equipment Containing PCB. ....	41
<b>Chapter 17—SAFE CLEARANCE REQUIREMENT</b>	<b>42</b>
17.1. Safe Clearance Requirement.....	42
17.2. Switching and Blocking Procedures.....	42
17.3. Tagging Procedures. ....	43
17.4. Underground Distribution Systems.....	43
17.5. Grounding Lines and Equipment.....	43
<b>Chapter 18—ENERGIZED CIRCUITS</b>	<b>44</b>
18.1. Energized Circuits.....	44
18.2. Electrical Hand Holes.....	44
18.3. Low Voltage Electrical Panels.....	44
18.4. Electrical Manholes Containing Low-Voltage Circuits.....	44
18.5. Electrical Work Not In Manholes or Hand holes.....	44
18.6. Electrical Work in Manholes Containing Distribution Voltage.....	45
18.7. Electrical Manholes Containing Transmission-Voltage Circuits.....	47
<b>Attachment 1—GLOSSARY OF REFERENCES AND SUPPORTING INFORMATION</b>	<b>48</b>
<b>Attachment 2—SCHEDULED MAINTENANCE FOR GROUNDING SYSTEMS.</b>	<b>57</b>
<b>Attachment 3—BASIC REQUIREMENTS FOR GROUNDING SYSTEMS</b>	<b>71</b>
<b>Attachment 4—BASIC BONDING REQUIREMENTS</b>	<b>78</b>
<b>Attachment 5—LIGHTNING PROTECTION SYSTEMS</b>	<b>88</b>
<b>Attachment 6—MAINTENANCE SELF-CHECK FOR EXPLOSIVES FACILITIES</b>	<b>91</b>
<b>Attachment 7—TESTING REQUIREMENTS</b>	<b>92</b>
<b>Attachment 8—REQUIREMENTS FOR WEAR OF MILITARY UNIFORMS WITH ARC THERMAL PERFORMANCE VALUE (ATPV) RATED PERSONAL PROTECTIVE EQUIPMENT (PPE)</b>	<b>103</b>

## Chapter 1

### ROLES AND RESPONSIBILITIES

#### *Section 1A—Maintenance*

#### **1.1. The Assistant Secretary of the Air Force Installations, Environment, and Energy (SAF/IE) shall:**

1.1.1. Be responsible for all doctrine, strategy, policy, guidance, and resource advocacy related to the Air Force electrical systems and grounding program.

#### **1.2. The Headquarters, United States Air Force, Deputy Chief of Staff for Logistics, Engineering and Force protection, Directorate of Civil Engineers (AF/A4C) shall:**

1.2.1. Be responsible for Air Force Civil Engineering policy, strategy, doctrine, oversight, directive guidance, and resource advocacy.

1.2.2. Be responsible for non-directive guidance related to the Air Force electrical systems and grounding program.

1.2.3. Be responsible and responsible for the career field management of all Air Force Electrical Systems personnel and advocate to ensure the Air Force has adequate combat electrical systems capability.

#### **1.3. The Air Force Installation and Mission Support Center (AFIMSC) shall:**

1.3.1. Support the development of Air Force policy, strategy, doctrine, directive guidance, and oversight related to the Air Force electrical systems and grounding program.

1.3.2. Be responsible for the development of non-directive publications and resource advocacy related to the Air Force electrical systems and grounding program.

#### **1.4. The Air Force Civil Engineer Center (AFCEC) shall:**

1.4.1. Support the development of Air Force policy, strategy, doctrine, directive guidance, oversight, and resource advocacy related to the Air Force electrical systems and grounding program.

1.4.2. Provide the Air Force electrical systems and grounding program subject matter expert(s) (SME) to act as the Air Force senior consultant(s).

1.4.3. Execute the Air Force electrical systems and grounding program by setting standards, developing procedures, and providing technical assistance to implement Air Force policy and programs. This includes criteria for design, maintenance, repair, and management of grounding and bonding systems in accordance with mandatory requirements of Unified Facilities Criteria (UFC) 3-520-01, *Interior Electrical Systems*; UFC 3-550-01, *Exterior Electrical Power Distribution*; UFC 3-575-01, *Lightning and Static Electricity Protection Systems*; and UFC 3-580-01, *Telecommunications Interior Infrastructure Planning and Design*.

1.4.4. Be responsible to develop, maintain, and approve non-directive guidance to implement the Air Force electrical systems and grounding program.

- 1.4.5. Consult with SAF/IE and AF/A4C on all non-directive guidance and execution of the Air Force electrical systems and grounding program.
- 1.4.6. Assist Major Command and installation electrical systems and grounding personnel to implement an effective electrical systems and grounding program. Provide technical support for Direct Reporting Units (DRU) and small units in accordance with this AFMAN.
- 1.4.7. Coordinate with other service agencies on military electrical systems and grounding program.
- 1.4.8. Review emerging and evolving technologies and evaluates for applicability to the Air Force.
- 1.4.9. Evaluate grounding and bonding training conducted internally to the Air Force, conducted by the Defense Ammunition Center (DAC), and conducted by the private sector.
- 1.4.10. Assist DRUs and Air Force installations with inspecting grounding and bonding systems and with troubleshooting electrical issues suspected to stem from grounding and bonding issues and discrepancies.
- 1.4.11. Assists Air Force Safety Center (AFSEC) and Inspector General (IG) personnel with determining the equivalency of grounding and bonding protection systems.

**1.5. The Base Civil Engineer (BCE) shall:**

- 1.5.1. Provide oversight and support in accordance with DoD, federal, state, and legally applicable host nation laws. **(T-0)**.
- 1.5.2. Provide facilities, equipment, and material to support the local electrical systems and grounding program. **(T-0)**.
- 1.5.3. Maintain lightning and grounding systems specifically identified in **Table A2.1** according to the procedures within, or procedures referenced by, this AFMAN. Wavier tiers per grounding system provided within table.
- 1.5.4. Ensure that user organizations identified in **Table A2.1** are aware of their maintenance responsibilities. **(T-2)**.
- 1.5.5. Train users to perform their responsibilities to inspect and maintain lightning and grounding systems as identified in **Table A2.1** when requested. On installations with privately owned electrical utility systems, consult with the owner. **(T-2)**.
- 1.5.6. Review the lightning protection system record drawings on each facility at least annually or after repair actions (including facility repairs and construction additions by contractors) have been completed.
- 1.5.7. Ensure that, for all functions of the civil engineer squadron that are contracted (e.g., base operations support (BOS) and contractors supporting contractor-maintained government-owned facilities and installations), the responsibilities listed within this AFMAN are included in the contract, as applicable.
- 1.5.8. Ensure compliance with applicable codes and specifications in **Attachment 1** unless modified in this AFMAN, or deviations are justified due to local conditions. **(T-1)**.

1.5.9. **(Added-USAFE-AFAFRICA)** The Base Civil Engineer (BCE) must designate in writing the LPS manager. For a United States Air Force (USAF) MUNSS unit, the MUNSS commander will designate in writing an LPS monitor or representative.

**1.6. (Added-USAFE-AFAFRICA) The Munition Support Squadron (MUNSS) shall:**

1.6.1. **(Added-USAFE-AFAFRICA)** MUNSS Responsibilities. The MUNSS LPS Monitor's primary role in the LPS program will be to serve as the liaison between the MUNSS commander and host nation personnel responsible for maintaining LPS. The MUNSS LPS Monitor responsibilities are as follows:

1.6.1.1. **(Added-USAFE-AFAFRICA)** Maintain a complete listing of MUNSS Weapon Storage and Security System (WS3) related facilities.

1.6.1.2. **(Added-USAFE-AFAFRICA)** Ensure all WS3 related facilities have installed LPS with certification of conformance signed by a host nation electrical engineer that the LPS conforms to host nation standards.

1.6.1.2.1. **(Added-USAFE-AFAFRICA)** Certification of conformance shall be a memo from the host nation to the MUNSS commander indicating installed LPS on all WS3 related facilities complies to host nation standards of design, installation, inspection, and maintenance as outlined in ACE Directive 80-6.

1.6.1.3. **(Added-USAFE-AFAFRICA)** Ensure testing of LPS installed on WS3 related facilities meets the frequency and required ohmic values of AFMAN 32-1065, **Table A2.1.**, and **Attachment 4**. Of this supplement as a minimum or meets the host nation standard, whichever is more strict.

1.6.1.4. **(Added-USAFE-AFAFRICA)** Perform visual inspections of installed LPS in accordance with AFMAN 32-1065, **paragraphs 7 and 8**, including verifying operational condition of installed surge suppressors. Forward any discrepancies found to host nation for repair, to the 52 CES LPS Manager and the MAJCOM/AFIMSC Det 4 for follow up.

1.6.1.5. **(Added-USAFE-AFAFRICA)** Maintain copies of the past six test cycles, and develop a trend analysis from the test results. Notify the 52 CES LPS Manager and MAJCOM/AFIMSC Det4 representative if any of the reading fails to meet host nation or AFMAN 32-1065 standards.

1.6.1.6. **(Added-USAFE-AFAFRICA)** Ensure surge protection is installed on all equipment associated with the MUNSS WS3 mission and be familiar with procedures and/or actions to verify surge protectors are operational. Be able to identify where the surge protection devices are installed and how to identify if one has been tripped. Maintain a sketch with all installed surge protection devices.

1.6.1.7. **(Added-USAFE-AFAFRICA)** Ensure host nation provides detailed LPS testing procedures and criteria to MUNSS LPS monitor. LPS testing procedures and criteria shall include, as a minimum, a checklist for visual and ohm inspection items, instrumentation setup procedures, building testing procedures, and certification that testing procedures and criteria meet host nation standards.

1.6.1.8. **(Added-USAFE-AFAFRICA)** All MUNSS using host nation LPS standards must have a Joint Operating Instruction (JOI) signed by the MUNSS Commander and Host

Nation Installation Commander. The JOI at a minimum will contain the following information:

- 1.6.1.8.1. **(Added-USAFE-AFAFRICA)** Identify whether LPS is maintained under host nation standards or in accordance with AFMAN 32-1065
- 1.6.1.8.2. **(Added-USAFE-AFAFRICA)** Host Nation Responsibilities.
- 1.6.1.8.3. **(Added-USAFE-AFAFRICA)** MUNSS Responsibilities.
- 1.6.1.8.4. **(Added-USAFE-AFAFRICA)** Testing Procedures.
- 1.6.1.8.5. **(Added-USAFE-AFAFRICA)** Testing Frequencies.
- 1.6.1.8.6. **(Added-USAFE-AFAFRICA)** Testing values for ohm readings.
- 1.6.1.9. **(Added-USAFE-AFAFRICA) Responsibilities.** Persons appointed at locations where base civil engineering is not provided will receive training according to **paragraph 4.1** in order to perform visual inspections and ensure host nation personnel are adequately accomplishing BCE inspections outlined in **Attachment 2**.

## Chapter 2

### RECORDKEEPING AND REVIEW FOR EXPLOSIVES FACILITIES.

**2.1. Inspectors and testers.** Inspectors and testers must compile and maintain records of their inspections and tests. **(T-1).** Records should include the following (sample records are provided in **Attachment 6**, Figures **A7.6**, **A7.7**, **A7.8**, and **A7.9**):

- 2.1.1. A sketch of the grounding and lightning protection system is provided showing test points and where services enter the facility. The sketch should also show the location of the probes during the ground resistance test. Separate sketches are suggested for static, earth ground, and lightning protection systems on large complex facilities. See **Figure A7.8** and **Figure A7.9** for examples of sketches or drawings that contain required information.
- 2.1.2. Date action was performed.
- 2.1.3. Inspector's or tester's names, duty location or agency and contact information.
- 2.1.4. General condition of air terminals, conductors, and other components.
- 2.1.5. General condition of corrosion protection measures.
- 2.1.6. Security of attachment for conductors and components.
- 2.1.7. Resistance measurements of the various parts of the ground terminal system.
- 2.1.8. Variations from the requirements of this AFMAN.
- 2.1.9. Discrepancies noted and corrective actions taken.
- 2.1.10. Dates of repairs.

**2.2. The Base Civil Engineer (BCE).** The BCE will review records for deficiencies; also analyze the data for undesirable trends. If test values differ substantially from previous or original tests obtained under the same test procedure and conditions determine the reason and make necessary repairs. **(T-1).**

**2.3. Inspectors and testers.** Inspectors and testers will keep test and inspection records in accordance with DoDM 6055.09 Volume 2 DoD *Ammunition And Explosives Safety Standards: Explosives Safety Construction Criteria*. **(T-1).**

**2.4. Mandatory Review and Update of Record Drawings for Nuclear-Capable Weapons and Munitions Storage and Maintenance Facilities.** Reproducible lightning protection system (LPS) drawings are required to be included in record drawings and available for immediate use by AFSEC in initial and updated explosives site plans. The BCE will ensure the record drawings contain:

- 2.4.1. Dimensions and material sizes for all LPS materials from top view and applicable elevations. **(T-2).**
- 2.4.2. Identification of test points. **(T-2).**
- 2.4.3. A 100-foot (30.5-meter) radius rolling sphere superimposed on elevations. (See **Figure A7.10** for a sample drawing.) **(T-2).**

**2.5. Active and ongoing projects.** No ongoing or currently active project (awarded or under design) on nuclear, nuclear-capable, weapons storage area (WSA) or munitions storage areas (MSA) shall be accepted until drawings are delivered to and approved by the BCE. BCE may designate a representative, they need to do so in writing. Drawings must meet American National Standards Institute (ANSI), Architectural Graphic Standards (AGS), and Architectural Engineering and Construction (AEC) standards for content, abbreviations, reproducibility, and graphics. A signature by the BCE or their designated representative is required as proof of receipt and approval of as-built drawings. **(T-2).**

**2.6. Contract for a lightning protection system project.** The contract for a lightning protection system project, or for any project on a facility containing a lightning protection system, shall require an LPS inspection by other than the designer and installer, prior to acceptance of the project. This may be accomplished by compliance with UFC 3-575-01, third-party inspection requirements, or by advanced government training, as outlined in **paragraph 6.2** of this AFMAN. Projects calling for a facility addition, with or without addition to the existing LPS, shall consider the configuration of the overall facility LPS in the design. Projects of this type shall ensure the final LPS as a whole is compliant with this AFMAN and National Fire Protection Association (NFPA) 780, in that priority order. **(T-2) Chapter 12** applies for facilities housing explosives, whether permanent or temporary. See AFMAN 91-201, *Explosive Safety Standards*, for testing requirements. **(T-0).**

## Chapter 3

### FORMS

**3.1. Forms for inspectors and testers.** Inspectors and testers will provide copies of completed forms to the facility user. For munitions facilities maintained by host nation civil engineers, the using agency must receive a copy of the completed forms. **(T-1)**.

3.1.1. Sample questions and Visual Inspection Forms, for inspection and test records are provided in **Attachment 6**, Figures **A7.6**, and **A7.7**

3.1.2. Either the sample forms or the Air Force General Purpose Form (3100 series) may be used to record test results for other-than-explosives facilities.

## Chapter 4

### PERSONNEL QUALIFICATIONS.

**4.1. General Qualifications.** Workers maintaining, repairing, modifying, and testing grounding systems must be thoroughly familiar with test equipment operation, lightning protection, grounding, bonding theory, practices, referenced codes, standards, specific requirements, and procedures in this AFMAN. DAC course number 4E-F37 645-F21 (formerly referred to as AMMO-47), AMMO-48, or an official on-the-job (OJT) program. If OJT is selected, the trainee must be instructed and mentored by a worker who has completed AMMO-47 or AMMO-48 within the last three years, and training milestones comparable to those in formal training must be tracked and documented by the electrical superintendent. Minimum OJT program is 6 months. Workers will renew maintenance training every three years, +/- one month. One person with completion of AMMO-47 or AMMO-48 within the past three years must be part of the electrical shop at all times. **(T-2).** Attachments 2 through 6 provide information suitable for use in training and familiarization. **Exception:** ANG will determine training requirements for their technicians that follows this guidance as closely as reasonably possible.

4.1.1. **(Added-USAFE-AFAFRICA)** All MUNSS LPS Monitor must receive training prior to assumption of duties. DAC course number 4E-F37 645-F21 (formerly referred to as AMMO-47), AMMO-48, or an official on-the-job (OJT) program, If OJT is selected, the trainee must be instructed and mentored by a worker who has completed AMMO-47 or AMMO-48 within the last three years, and training milestones comparable to those in formal training must be tracked and documented. The MAJCOM/AFIMSC DET 4 Electrical Engineer or his representative can train individuals unable to attend the AMMO47/48 course. The MAJCOM/AFIMSC DET 4 Electrical Engineer or representative will document the training and certify the individuals as capable of performing the associated tasks.

**4.2. Advanced Qualifications.** In addition to general qualifications, government personnel may meet the third party inspector requirements of this AFMAN with additional training. Government personnel responsible for inspection and acceptance of contracts, including simplified acquisition of base engineering requirements (SABER) contracts, on facilities with LPS installation have the following requirements: For official (designated in writing by the BCE) CE inspectors, advanced qualifications shall be renewed every three years. AFRC units and ANG may comply with UFC 3-575-01, in lieu of these advanced qualifications for a third-party inspector. **(T-1).**

4.2.1. Attendance and completion of the Senior Inspector AMMO-50 course, or equivalent, with completion certificate. AFCEC/CO must approve the equivalent course, based on content, prior to participation. An equivalent course would be one in which all topics in AMMO-50 are covered, all codes and references in AMMO-50 are addressed, a class field inspection is conducted for the purpose of identifying real-world common discrepancies, and certification must be conditional upon passing a graded, comprehensive examination, which includes an LPS design, essay questions, and code Air Force criteria (with focus on this AFMAN) based questions. A certificate of completion and competency within three years prior to the inspection is required.

4.2.2. Air Force Specialty Code (AFSC) 3E0X1, 7-level, with training commensurate with that level of expertise and experience or, for civilians, training and experience equivalent to this AFSC.

4.2.3. Proficiency using test equipment required to obtain test readings for inspections referenced in this AFMAN.

**4.3. Project Acceptance Qualifications.** Air Force-approved inspectors, with authority to recommend acceptance of LPSs that protect explosives facilities and communications facilities, are limited to:

4.3.1. Nationally recognized inspection agencies who have a minimum 10 years of experience in inspection of LPS for explosives facilities on DoD or Department of Energy (DoE) installations and have exhibited accuracy in identifying discrepancies, evidenced by no modifications having been required for the system during the warranty period (see UFC 3-575-01). Discrepancies must not be listed on any database with public access. **(T-1)**.

4.3.2. Air Force personnel with a minimum six years of experience in LPS maintenance and have taken an advanced lightning protection systems senior inspector course approved by the Air Force. **(T-2)**.

4.3.3. Air Force-contracted maintenance personnel (BOS or other contracted maintenance to government-owned facilities) shall meet the experience levels of **paragraph 4.3.2**. **(T-2)**.

**4.4. IG and Nuclear Surety.** Qualifications required for Nuclear Surety Inspections (NSI), Nuclear Surety Staff Assistance Visits (NSSAV), and Initial Nuclear Surety Inspection (INSI) of nuclear facilities:

4.4.1. Military technicians must:

4.4.1.1. Attend and complete the initial Air Force Inspection Agency inspector's course. **(T-1)**.

4.4.1.2. Attend and complete the AMMO-47, AMMO-48, or equivalent experience, with completion certificate or supervisor memorandum of qualification stating what equivalent course was taken on file. **(T-1)**.

4.4.1.3. Attend and complete an advanced commercial lightning protection course per **paragraph 4.2**. **(T-1)**.

4.4.1.4. AFSC 3E0X1, 7-level, with training and experience commensurate to that intended level of expertise. **(T-1)**.

4.4.1.5. Proficiency using test equipment required to obtain test readings for inspections referenced in this AFMAN, validated in writing by a supervisor. **(T-1)**.

4.4.2. Civilian must:

4.4.2.1. Attend and complete AMMO-47, AMMO-48, or equivalent experience, with completion certificate or supervisor memorandum of qualification on file. **(T-1)**.

4.4.2.2. Attend and complete an advanced commercial lightning protection course per **paragraph 4.2.2**. **(T-1)**.

4.4.2.3. Have 10 years of experience in maintenance and inspection of LPS in a field equivalent to AFSC 3E0X1, 7-level. **(T-1)**.

4.4.2.4. Proficiency using test equipment required to obtain test readings for inspections referenced in this AFMAN, validated in writing by a supervisor. **(T-1)**.

## Chapter 5

### DEVELOPING PROCEDURES

**5.1. Standard and procedures.** The organization performing inspections and tests must develop standard procedures based on the requirements in this AFMAN. To avoid potential security issues, inspection information providing the facility name, facility number, street address, may include base on which the facility is located must not be posted to any site available for public access. (T-0).

## Chapter 6

### TESTING REQUIREMENTS

#### *Section 6A—Grounding Resistance and Continuity Tests and Visual Inspections*

**6.1. Testing Requirements.** See [Attachment 7](#) for resistance and continuity test requirements for typical systems. **(T-1)**. Instruments must be able to measure 10 ohms  $\pm 10$  percent for ground resistance tests and 1 ohm  $\pm 10$  percent for continuity testing.

6.1.1. Only instruments designed specifically for earth-ground systems are acceptable for ground resistance testing.

6.1.2. Follow the manufacturer's instruction manual except as modified herein when using the instruments.

6.1.3. Earth-ground resistance should be less than 25 ohms at the service grounding electrode unless otherwise specified in this AFMAN. **Note.** The National Electrical Code (Articles 250.52 and 250.53) does not require 25 ohms to ground for a ground ring (counterpoise); therefore, ground rings are not required to be tested for resistance. Resistance test requirements are for the grounding electrodes bonded to the ground ring. Continuity testing is required for the ground ring (counterpoise).

6.1.4. Periodic tests should be made at approximately the same time each year to minimize distortions to readings resulting from seasonal changes see [Attachment 2](#). **(T-1)**.

6.1.5. If the resistance measured during continuity tests is greater than 1 ohm, check for deficiencies, repair, and then retest. **NOTE:** When performing a continuity test over very long lengths of conductors (more than 65 feet (20 meters) with no parallel paths), readings above 1 ohm but less than 3 ohms may occur. This can be due to the added resistance of the test wire and is acceptable. Documentation of the procedures is required and kept on file. The base electrical engineer may modify the test procedures to compensate for local conditions as long as the intent of the test is still met.

## Chapter 7

### VISUAL INSPECTIONS OF LIGHTNING PROTECTION SYSTEMS

**7.1. Inspections.** Inspector will annually inspect all visible parts of the system. **(T-1)**. Pulling or tugging on conductors and connections to ensure soundness is a necessary part of these inspections, be careful not to damage the system in the process. Visual or physical inspection must determine if:

7.1.1. The system is in good repair.

7.1.2. Loose connections might be causing high-resistance joints.

7.1.3. Corrosion or vibration has weakened any part of the system.

7.1.4. Down conductors, roof conductors, ground terminals and all other components are intact, air terminals exceeding 24 inches in length are supported at a point not less than one-half their length, and no components or fasteners are missing.

7.1.5. Braided bonding wires or straps are excessively frayed (cross-sectional area reduced by half).

7.1.6. Ground wires and down conductors, air terminals (for earth-covered magazines (ECM), masts, or poles that might have been damaged by mowers, equipment, or vehicles.

7.1.7. Conductors and system components are securely fastened to mounting surfaces. Position connections to better protect against accidental displacement. Do not use Adhesive-type fasteners.

7.1.8. Project additions or alterations to the protected structure require additional protection. See UFC 3-575-01.

7.1.9. Surge protective devices (SPDs) supporting facilities and facility service appear damaged or indicator lamps signal an operation has occurred. **Note:** Inspection, repair, and replacement of SPDs protecting equipment are the responsibility of the equipment owner or user.

7.1.10. The system complies with the intent of applicable sections of the most recent version of NFPA 780, unless otherwise noted in this AFMAN. **(T-1)**.

## Chapter 8

### VISUAL INSPECTION OF FACILITY GROUNDS

#### *Section 8A—Grounding and Lightning Protection Requirements*

**8.1. Visual Inspection.** Unless otherwise specified by references in [Table A2.1](#), conduct visual inspections as follows. Inspect all visible and accessible parts of the facility grounding system. Validate satisfactory condition and verify the installation meets the National Electric Code (NEC) requirements (**T-1**). Typical items to check include:

8.1.1. The system is in good repair.

8.1.2. No loose connections are visible.

8.1.3. The system neutral is grounded at the service entrance. This may be achieved either by bonding the neutral bus to the ground bus in the main distribution panel or by connection to the grounding electrode (single point ground) for the facility.

8.1.4. Separately derived systems are properly grounded.

8.1.5. Flashover protection (bonding) is installed on insulating fittings on underground metallic pipelines entering the facility.

8.1.6. Grounding systems and static systems within the facility are bonded together at floor level or at or below ground level outside the building.

## Chapter 9

### INTRODUCTION

#### *Section 9A—Grounding and Lightning Protection Requirements*

**9.1. Grounding and lightning protection requirements.** This section covers requirements for grounding and lightning protection systems, including systems installed on or in areas such as explosives buildings, magazines, operating locations, and aircraft shelters. Use these requirements when inspecting to determine compliance and when repairing or modifying systems. See AFMAN 91-201.

## Chapter 10

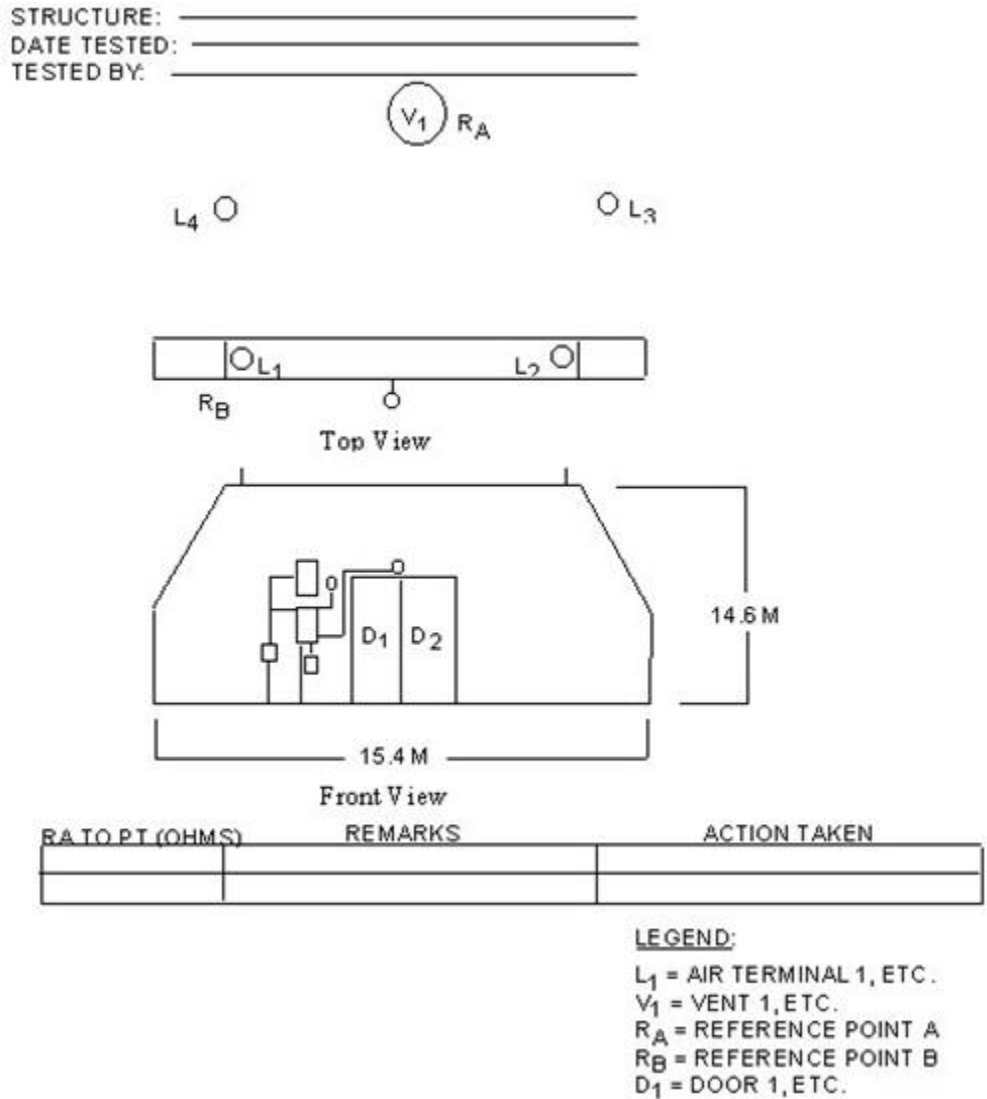
### TESTING AND INSPECTING STATIC AND LIGHTNING PROTECTION SYSTEMS AND GROUNDING

**10.1. Procedures.** Use [Attachment 4](#) and [Attachment 5](#) as a guide for establishing proper maintenance procedures and as a self-check prior to inspections. **(T-1)**.

**10.2. Inspection and Testing.** Visually inspect and test the static, grounding, and lightning protection systems for buildings and facilities in accordance with Section A, *Maintenance Policy*, and Section B, *Grounding Resistance and Continuity Tests and Visual Inspections*, and the special requirements in this section. **(T-1)**.

**10.3. Records.** Inspectors and testers will keep test and inspection records in accordance with DoDM 6055.09, for a minimum of six inspection cycles. **(T-1)**. [Figure 10.1](#) is an example sketch of a grounding and lightning protection system with test points.

**Figure 10.1. Example Sketch of Test Points (Typical).**



**10.4. (Added-USAFE-AFAFRICA) USAFE Testing.** According to ACE Directive 80-6, Volume 2/US EUCOM Directive (ED 60-10), *Nuclear Surety Management*, and ACE Directive 80-6, Volume 2, Part II/ED 60-12, *Nuclear Surety Management for the WS3*, as a minimum, test European weapon storage areas lightning protection systems, and hardened aircraft shelters with WS3 vaults under United States Air Force (USAF) control, according to U.S. standards and testing procedures. Host nation requirements may be used if they meet or exceed U.S. requirements. This includes LPS and facility grounding testing schedules that are accomplished more frequently by many host nations.

## Chapter 11

### STATIC PROTECTION

**11.1. Static Protection for Electronics and Electrical Equipment.** The best methods to eliminate or reduce the hazard from static electricity are bonding and grounding. Bonding minimizes potential differences between conductive objects. Grounding minimizes potential differences between objects and the ground. Inspectors will inspect and test facilities for compliance with NFPA 77, *Static Electricity*, which contains the minimum acceptable static grounding and bonding requirements for Air Force activities, except as modified in this AFMAN. **(T-0)**. See [Attachment 3](#). **(T-1)**.

11.1.1. Bonding conductors shall be large enough to withstand mechanical damage. Minimum size for existing bonding conductors is American wire gauge (AWG) No. 8. If bonding conductors are in areas of high use or are subject to physical damage, make repairs with wires no smaller than AWG No. 6 copper. Static grounds for portable or movable equipment must be of braided cable for added flexibility. **(T-0)**.

11.1.2. Static grounds shall be 10,000 ohms to ground or less, unless otherwise stated. **(T-0)**. Static electricity creates extremely small (on the magnitude of milliamps) currents, so even this large resistance is small enough to bleed off static charges. But because the static grounding system must be connected to the facility grounding system, resistances of less than 25 ohms are common.

**11.2. Static Bus Bars.** Static bus bars are usually 2-inch by 0.25-inch copper bars installed on the interior wall of the facility. The length will vary for new facilities but design the bar itself to be no closer than 12 inches from the intersection of an interior wall with an exterior wall for side-flash reasons. See [Figure 11.1](#) for bus bar end and for transition at floor level, around windows, and doorways (requires depression for ground wire).

11.2.1. Design the down conductor location so that it does not “cross” an interior static bus bar. For existing facilities at which this condition exists, perform side-flash calculations to ensure that the wall thickness exceeds the side flash distance. Typically, the side flash distance through the wall, using the basic bonding formula (BBF), exceeds the calculated side-flash distance at the normal static bus bar height up to 48 inches (1.2 meters).

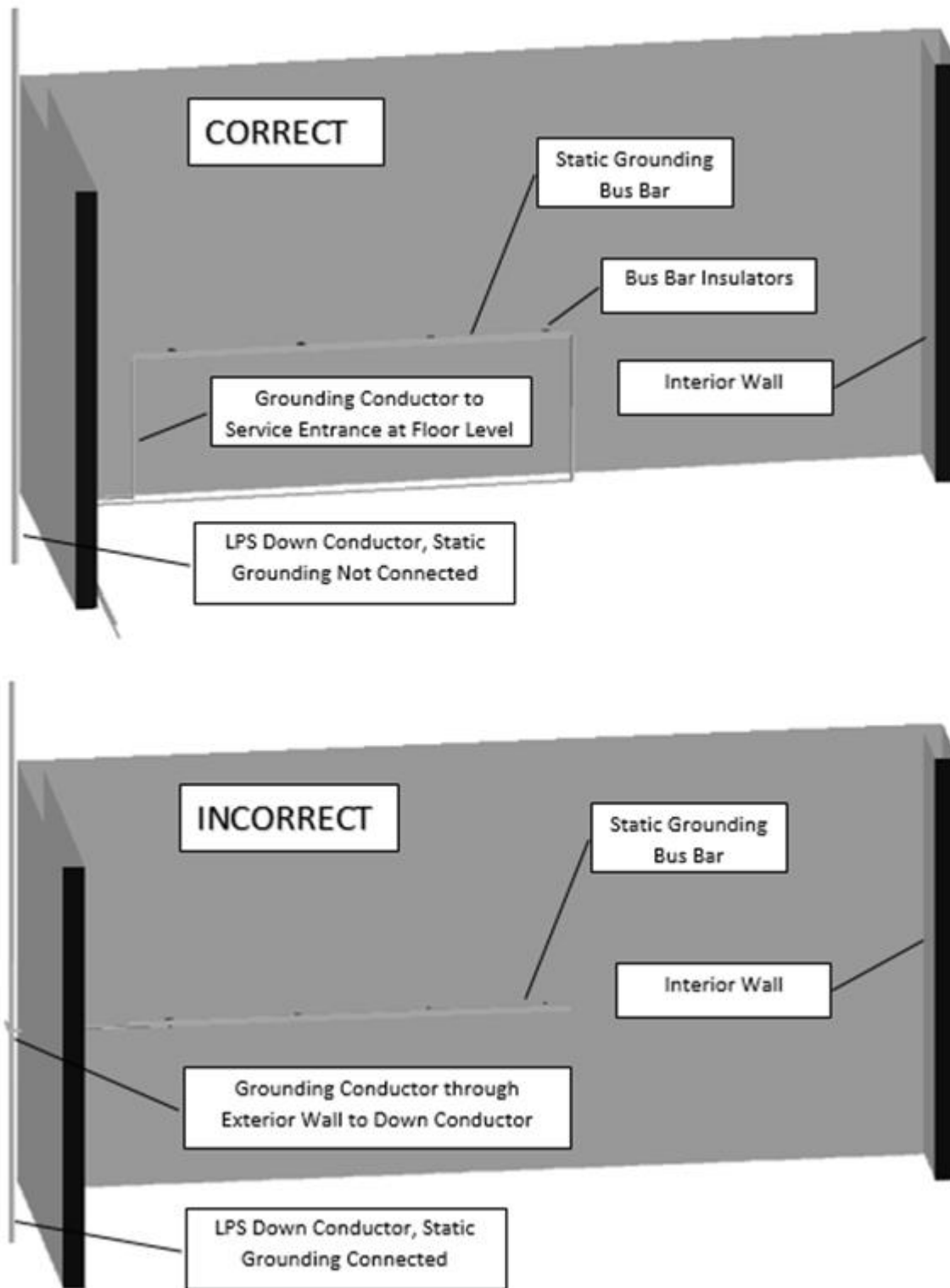
11.2.2. If installed within side flash distance, relocate either the down conductor or discontinue the static bus bar 1 foot (0.3 meter) either side of the exterior down conductor location and bond the two sections of the static bus bar at floor level, using a 1/0 copper conductor. **Note:** For structures exceeding 250 feet (76 meters) in perimeter, if relocating the down conductor results in a separation distance of greater than 100 feet (30.5 meters) between down conductors, an additional down conductor may be necessary.

11.2.3. The grounding conductor from the static bus bar shall be connected directly to the facility grounding electrode system. See [Attachment 6](#) for testing requirements. Use static bus bars only for static grounding.

11.2.4. Communications systems, electrical conduit, intrusion detection systems, and other permanently installed systems shall not use the static bus bar as a system ground. As a general rule, do not connect a static bus to any facility metal body or use this bus to ground structural components of a facility; however, coincidental connections of the bus bar through its

anchoring, mounting system are acceptable, as is the mounting of the static bars on the skin of a metal structure.

11.2.5. Portable grounding straps from equipment to the static grounding bus are not real property; therefore, visual inspections and continuity tests for these straps are the responsibility of the user. **(T-0)**.

**Figure 11.1. Grounding Static Bus Bar on Interior Wall.**

**11.3. Belting Requirements.** On equipment such as belt-driven compressors and conveyor belts, if static electricity is a hazard, use non-static-producing belting. Belting must have a resistance not

exceeding 1,000,000 ohms when measured according to Institute of Electrical and Electronics Engineers (IEEE) Standard 142, *IEEE Recommended Practice for Grounding for Industrial and Commercial Power Systems (Green Book)*, reference **Chapter 3. (T-0)**.

**11.4. Conductive Floor Grounds.** If the electronic equipment within a facility requires a resistance of the floor-to-ground of less than 1,000,000 ohms, a conductive floor is required. This resistance value is the sum of the resistance of the floor plus a person, added together. Static dissipative footwear which is a type of personal protective equipment (PPE) will ensure protection for personnel from electric shock hazard and will allow bleed-off of static buildup in personnel and equipment. Testing requirements are in **Attachment 7. (T-1)**. Using agency must keep a record of test results. **(T-1)**.

## Chapter 12

### LIGHTNING PROTECTION SYSTEMS

**12.1. Lighting protection requirements.** The following requirements will be used as a guide for facilities that require or possess lightning protection. **(T-1).**

**12.2. General.** Lightning Protection Systems must comply with NFPA 780 and UFC 3-575-01, whichever is more restrictive (except as modified herein). See **Attachment 4. (T-0).** Early streamer emission systems, charge dissipation systems, or other unconventional systems are not permitted. Parts and materials must carry the Underwriters Laboratories® (UL) label or equivalent, and must be listed for use on lightning protection systems. **(T-0).** Components not carrying a UL label or equivalent, or components carrying a UL label or equivalent and not listed for use on lightning protection systems, must be approved by the BCE or designated representative. **(T-2).** Facilities in foreign countries may use host nation codes and standards if they offer equivalent protection, as determined by the BCE, with concurrence from AFCEC/COSM and, for facilities housing explosives, approval of the DoD Explosive Safety Board (DDESB). **(T-0).** Otherwise, the status of forces agreement (SOFA) must specifically permit the use of host nation codes. Where the SOFA requires compliance with host nation codes, translate those required codes into English, make them available to all appropriate personnel, and conduct necessary training. Maintain all installed systems in accordance with this AFMAN. If an existing lightning protection system is no longer required, coordinate with the facility manager to remove the LPS. Test records of the LPS must remain with the facility for six inspection cycles. Inspections are required every 24 months. therefore, six inspection cycles are 24 months times 6 inspection cycles divided by 12 months per year or 12 years. **(T-1).**

**12.2.1. (Added-USAFE-AFAFRICA) Host Nation Codes and Standards.** For those facilities in foreign countries that must use host nation codes and standards, the BCE shall determine if required LPS systems meet U.S. standards. If this cannot be determined through on-site resources, the BCE must formally request AFIMSC/DET 4 Electrical Engineer assistance to evaluate the LPS systems installed at these locations. The AFIMSC/DET 4 Electrical Engineer will determine whether the host nation codes and standards offer equivalent protection; and coordinate with AFCEC/COSM and the Department of Defense (DoD) Explosives Safety Board (DDESB) according to **paragraph 14.1** Formal requests shall become a permanent part of LPS records.

**12.3. Bonding Requirements.** Adequate bonding is more important than grounding. Bonding ensures all metallic objects are at equal potentials to protect personnel against dangerous arcs or flashovers. Inspectors will inspect and test facilities for compliance with NFPA 780 and **Attachment 3 (T-0).**

**12.4. Resistance to Ground.** Low resistance is desirable but not essential for lightning protection. For most facilities and per NEC Article 250.53, *Grounding and Bonding*, (resistance to ground should be less than 25 ohms at the service grounding electrode. If 25 ohms cannot be achieved with the addition of a grounding electrode, a supplemental electrode may be necessary, depending upon the magnitude of resistance obtained and the contents of a facility being protected. The resistance to ground of a ground loop conductor is acceptable even if greater than 25 ohms. See **Attachment 2. (T-1).**

**12.5. Lightning Protection for Explosives Facilities.** AFMAN 91-201 identifies explosives facilities that require lightning protection systems. Use the basic practices in that AFMAN, with the following additions:

12.5.1. The system shall be designed for a 100-foot (30.5-meter) striking distance. **(T-0).** **Note:** an administrative, educational, or other non-explosives-type facility located within a weapons or munitions storage area may be designed for a 150-foot (45.7-meter) striking distance.

12.5.2. Installation of test wells or hand holes at corner grounding electrodes for existing connections to grounding electrodes is recommended to aid with access for testing unless conductors are exothermically welded to the grounding electrode and the exothermic weld is shown on record drawings.

12.5.3. Replace existing bolted connectors on down conductors and roof conductors, when in need of repair, with high compression or exothermic-weld type connectors. Connections to air terminals are an exception, but they must be tight and in good repair. Bolted connections to aluminum bodies (such as vents) and to metal bodies for the purpose of bonding are also acceptable. Brazing to metal bodies is not allowed for new construction due to the possibility of a cold weld with inadequate strength. **(T-0).**

12.5.4. The metal framework of a structure shall be permitted to be utilized as an air terminal and main conductor of a lightning protection system if it is equal to or greater than 3/16 (0.188) inch (4.8 millimeters) in thickness and is electrically continuous, either inherently or made. **(T-0).**

12.5.5. **(Added-USAFE-AFAFRICA) New Installation, Modification and Renovation.** All new installation, modification and renovation of Lightning Protection Systems for Explosive and Critical Communications Facilities shall be routed through AFIMSC DET 4 Electrical Engineer in the design and construction phases to ensure the systems are in compliance, with this AFMAN and coordinated with DDESB and AFCEC agencies.

**12.6. Explosives Facility with Large Perimeter.** New explosives facilities with a perimeter over 300 feet (91.4 meters) that require lightning protection and do not use the structural steel as an air terminal equivalent shall use either a mast system or an overhead wire system. See **Attachment 4** for requirements. **(T-1).** Such indirect air terminal designs are intended to provide lightning attachment away from the facility and not directly to the facility. It also reduces maintenance and installation costs. The BCE may waive this requirement (overhead or mast system). ECMs are not required to carry air terminals from headwall to headwall (for drive-through ECMs) or from headwall to air vent. **(T-2).**

Figure 12.1. ECM With Center Conductor and Air Terminals.

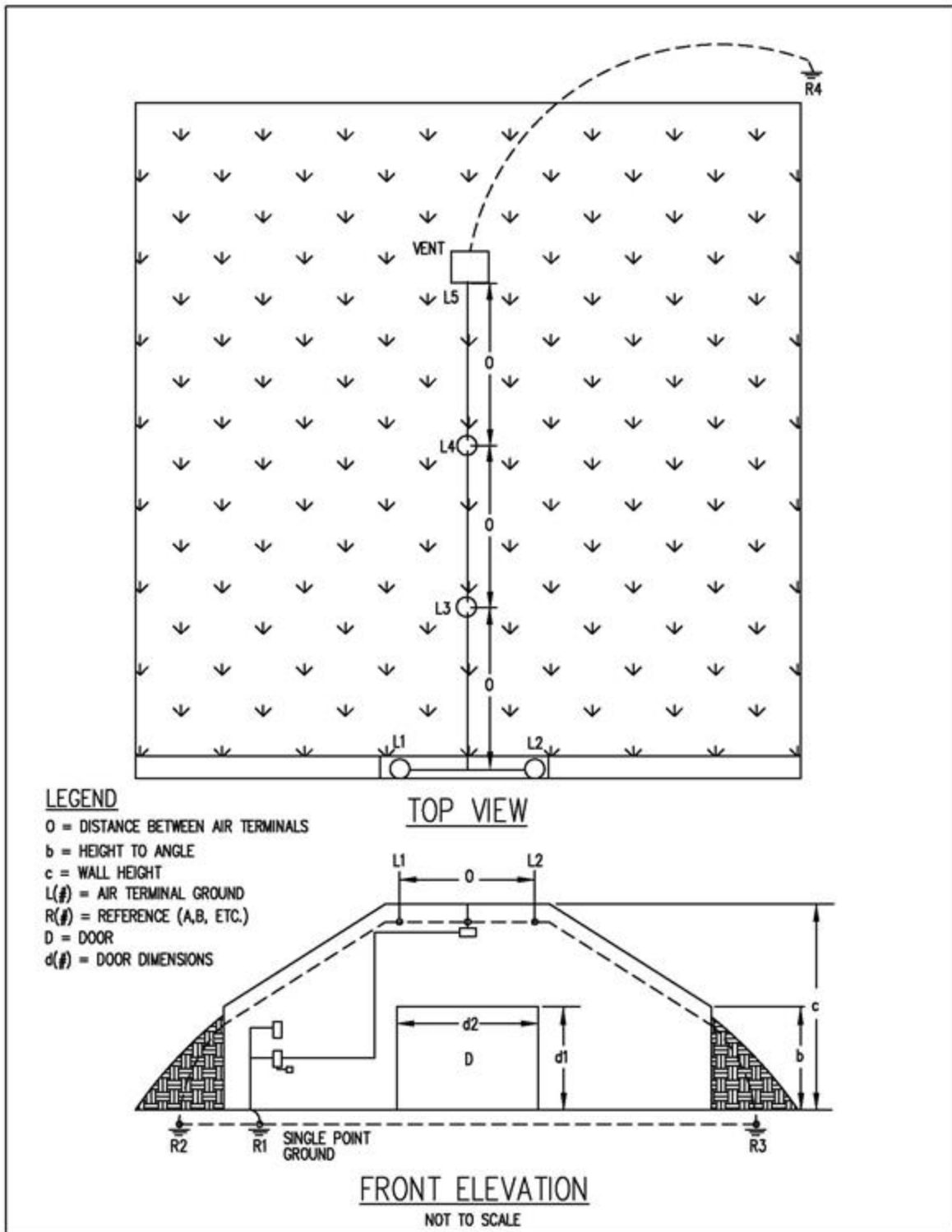
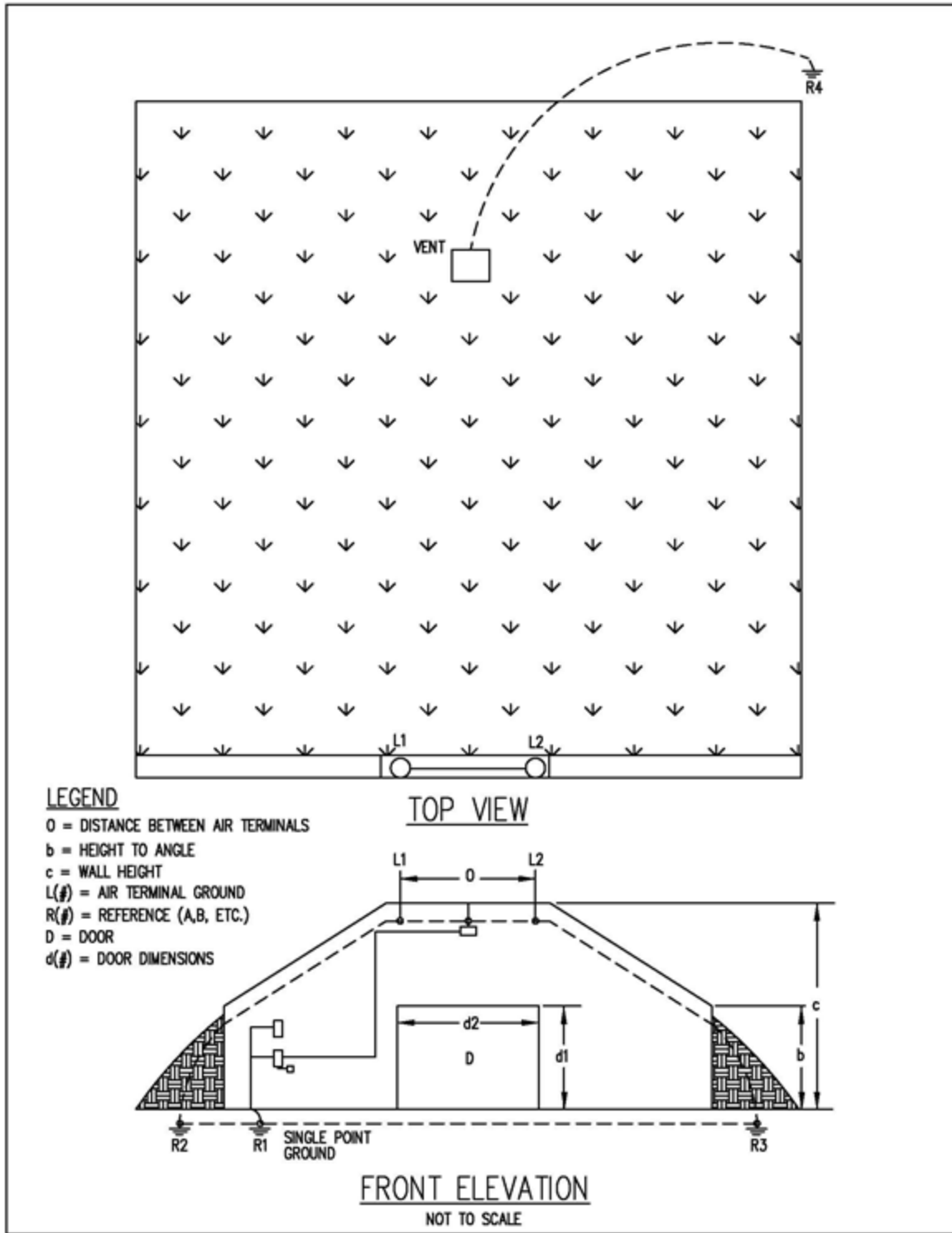


Figure 12.2. ECM Without Center Conductor and Air Terminals.



**12.7. Sunshades.** The metal framework of a sunshade structure shall be permitted to be utilized as an air terminal and main conductor of a lightning protection system if structural members are equal to or greater than 3/16 (0.188) inch (4.8 millimeters) in thickness and structural members are electrically continuous (either inherent or made) to ground. Grounding requirements depend upon the footing of the vertical support units (columns). Vertical support units with full footers require no further grounding. The flight line (to include sunshade areas) is evacuated once lightning is at a distance in nautical miles (NM]) determined by the base; therefore, step potential is not considered for sunshades. Vertical support units bolted to the apron concrete make it necessary to, as a minimum, install one grounding electrode at two diagonally opposite corners. Roof material, whether metallic or fabric, is of no consequence when considering the steel structure as a lightning protection system.

**12.8. Protective Aircraft Shelters (PAS) (also known as Hardened Aircraft Shelter (HAS)).** Aircraft shelters with continuous interior steel arches, either visible or validated by record drawings, provides a Faraday-like shield and therefore requires no air terminals. Exterior metallic ventilators with an enclosure at least 3/16 (0.188) inch (4.8 millimeters) in thickness do not require air terminals if properly bonded to the steel arch. Metallic ventilators less than 3/16 (0.188) inch (4.8 mm) in thickness must be protected by an air terminal bonded to the steel arch in accordance with NFPA 780. All metal bodies mounted to the steel arch shall be bonded and grounded in accordance with this AFMAN and NFPA 780. The facility grounding system shall also comply with this AFMAN and NFPA 780. Since the floor is designed to be separable from the walls, the walls and the floor shall be permanently bonded to a single grounding point or series of connected grounding points identified on record drawings. If no record drawings are available, continuity shall be validated by a minimum of four shell-to-ground tests interior to the facility. A sketch will be made, indicating test points, and this shall become the record drawing. Visual inspection will be conducted every 12 months and testing will be conducted every 24 months. **(T-0).**

**12.9. Lightning Protection for Above Ground Launch Structure.** Above ground launch structures shall be provided the same protection as explosive facilities (see paras [12.5](#) and [12.6](#)) with the following additions:

12.9.1. Lightning Protection for Above Ground Launch Structure will be designed in accordance with NFPA 780 and this document. Base the design on top 100 feet (30.48 meters) of the structure.

12.9.2. All structural metal shall be bonded.

12.9.3. When practical, structural steel members will be made electrically continuous and used as down conductors.

12.9.4. The structure will have an interconnecting ring conductor installed every 200 feet (60.91 meters) in height when the structural members do not form a ring every 200 feet (60.91 meters). In some cases, it will be necessary to attach temporary conductors between the fixed and moveable portions of the launch structure to ensure potential equalization.

12.9.5. All antennas, radomes, and dishes mounted external to the structure will have surge suppression installed where the conductor enters the launch structure.

**12.10. (Added-USAFE-AFAFRICA) Critical Communication Facilities.** Critical communication facilities are defined as the Local Monitoring Facility (LMF), Remote Monitoring Facility (RMF), Command Post (CP) and Alternate Command Post (Alt CP). All other

communication facilities will be classified as essential or general dependent on the organizational mission. The Communications Squadron commander or MUNSS Commander must identify additional facilities, critical to the surety mission, in writing to the BCE with approval from the installation base and, or wing commander.

## Chapter 13

### SURGE PROTECTION

**13.1. Surge protection.** Surge protection is required on electrical service entrances and on some interior distribution panels in accordance with NFPA 780. **(T-0)**. Protection shall meet the requirements of the following paragraphs. **(T-1)**.

13.1.1. SPD, formerly referred to as TVSS (transient voltage surge suppression), protect facilities and facility contents from transient voltages resulting from lightning surges, switching surges, and surges internal to the facility. SPDs may protect the upstream distribution system from the rapid switching effects of user-owned electronics.

13.1.2. For large facilities, SPDs are most effective when used in the form of tiered protection. Tiered protection means providing protection at main distribution panels, at secondary or sub-panels, and at the equipment point of use.

13.1.3. For protection of non-real property installed equipment, refer to the equipment manufacturers' requirements for surge protection. The owner of the communications or other equipment funds the purchase, installation, and maintenance of any surge protective devices required for the protection. To include items desired by the user for additional protection of communications and other equipment.

13.1.4. In facilities such as dormitories and other facilities with only basic electronics, low-dollar content, or with minimal occupants, surge protection may be met by the a lightning protection system.

13.1.5. Surge protection shall be provided for all incoming power to facilities with electronic-intensive training systems. **(T-3)**.

#### **13.2. WSAs, MSAs, and Communications Facilities:**

13.2.1. Standard, published, minimum 10-year unlimited replacement warranty on product. Entire unit shall be replaced upon detection of the failure of any mode. **(T-1)**.

13.2.2. All mode (10 modes), directly connected protection elements (l-n, l-g, l-l, n-g). Direct clamping l-n and l-l is required. **(T-1)**.

13.2.3. F1 polycarbonate enclosure or National Electrical Manufacturers Association (NEMA) 4 or NEMA 4X steel enclosure: Inaccessible to unqualified persons. **(T-1)**.

13.2.4. Internal over-current fusing on each phase for self-protection from failed component(s) and an internal disconnect for each phase. **(T-1)**.

13.2.5. Individual component level thermal fusing. **(T-1)**.

13.2.6. Bi-polar protection. **(T-1)**.

13.2.7. The SPD shall contain continuous self-monitoring devices with indicator lamps for each mode. **(T-1)**. These may be located inside enclosed areas such as mechanical rooms if an indicator lamp is provided in a visible area. Install the indicator lamp in a location that can easily be seen from a vehicle (to allow drive-by visual inspections), if permitted. Drive-by visual inspections allow maintenance personnel to quickly identify devices are operated and to assess whether a group of SPDs in a single area have operated.

13.2.8. Cable connection between a bus and SPD shall be minimum No. 10 AWG for installation at main distribution panels and sub-panels. **(T-1)**.

**13.3. Igloos or ECMs:** Up to 60A service.

13.3.1. Visible indicators of SPD operation on the exterior of facilities. Drive-by visual inspections may be an effective means of inspecting SPDs.

13.3.2. 60kA/mode to allow the following requirement.

13.3.3. 180kA/phase peak service surge current.

13.3.4. Non-modular. The entire unit shall be replaced upon detection of the failure of one mode of operation. Ease of installation shall not be traded for possible minimized protection level. **(T-1)**.

**13.4. Maintenance Facilities:** 400-600A service. **(T-1)**.

13.4.1. Visible indicators of SPD operation on the exterior of facilities. Drive-by visual inspections may be an effective means of inspecting SPDs.

13.4.2. 180kA/mode to allow the following requirement.

13.4.3. 240kA/phase peak service surge current.

13.4.4. Non-modular. The entire unit shall be replaced upon detection of the failure of one mode of operation. Ease of installation shall not be traded for possible minimized protection level. **(T-1)**.

**13.5. Communications Facilities:** Up to 1800A.

13.5.1. Visible indicators of SPD operation on the exterior of facilities or audible alarm.

13.5.2. 200kA/mode to allow the following requirement.

13.5.3. 600kA/phase peak service surge current.

13.5.4. Non-modular. The entire unit shall be replaced upon detection of the failure of one mode of operation. Ease of installation shall not be traded for possible minimized protection level.

**13.6. General Requirements:**

13.6.1. Nominal discharge current test at 20kA (UL testing allows 10kA or 20kA, but testing at 10kA is not allowed for Air Force facilities). **(T-0)**.

13.6.2. Unit type (NFPA 70, NEC, Article 285): **(T-0)**.

13.6.2.1. Type 1 unit is required for the supply side of the service or building disconnect means. **(T-0)**.

13.6.2.2. Type 2 or 3 units, when required by the equipment, must be installed on the load side of the overcurrent protective devices (not needed for igloos). **(T-0)**.

**13.7. User Requirements:** SPDs shall be provided on proprietary equipment by the communications provider or the tenant communications agency or group. **(T-1)**.

## Chapter 14

### APPLICATION AND SCOPE

#### *Section 14A—Electrical Safe Practices*

**14.1. Application and Scope.** This section applies to all electrical work done either in house or by contract when incorporated as a part of the contract documents on infrastructure and facilities that are maintained and operated by the Air Force, assigns supervisor responsibilities and provides necessary guidance to safely build, operate, and maintain electrical distribution systems and equipment. It complies with NFPA 70E, *Standard for Electrical Safety in the Workplace*, 29 CFR 1910, Subpart S, *Occupational Safety and Health Standards*, UFC 3-560-01, *Operation and Maintenance: Electrical Safety* and incorporates National Consensus Standards.

## Chapter 15

### SUPERVISOR RESPONSIBILITIES

**15.1. Personal Safety.** Supervisors must provide a safe and healthful work environment. **(T-0).** Supervisors must ensure facilities, work areas, equipment, and work procedures comply with safety, fire, and health policies. **(T-0).** Each supervisor must be thoroughly familiar with safe working practices, particularly those in UFC 3-560-01 and applicable standards and codes referenced in **Attachment 1** of this AFMAN. **(T-0).** Supervisors must report and document all injuries, even minor ones, as directed in AFI 91-202, *The US Air Force Mishap Prevention Program* and AFI 91-204, *Safety Investigations and Reports*. **(T-1).**

**15.2. Planning and Worker Awareness.** Supervisors must plan the work properly and ensure it is performed safely. **(T-0).** Supervisors must review job requirements with the workers and ensure they understand why and how to do the work, the hazards they may encounter and how to control them, and the proper procedures for working safely. **(T-0).** When the mission allows, coordinate de-energizing of circuits for safest possible working conditions. Supervisors are required to provide written procedures when working on energized circuits to ensure safe practices. **(T-0).**

**15.3. Training Assistance.** Supervisors will provide general and specific safety instructions and training to workers, ensure each employee has access to this AFMAN and UFC 3-560-01, and ensure they demonstrate satisfactory knowledge before performing any task. **(T-0).** Supervisors must document all training on AF Form 55, *Employee Safety and Health Record* or an alternative as permitted in AFMAN 91-202. **(T-1).**

15.3.1. Supervisors will, after initial job safety training, train employees annually on hazardous energy control, safe clearance, confined spaces entry, manhole, pole top and bucket truck rescue, shop operating instructions and review any Air Force mishap Cross-tell reports. **(T-0).**

15.3.2. Supervisors must instruct employees on identifying abnormal or hazardous existing conditions (e.g., switches left in an abnormal condition or bypassed, broken equipment temporarily fixed, changes to the one-line distribution map or schematic diagram, hazardous energy control tags or safe clearance tags left on unfinished jobs, etc). **(T-1).**

**15.4. Safety Meetings.** Supervisors will conduct weekly safety meetings. **(T-1).** As a minimum, safety meetings should cover the following topics annually:

15.4.1. Hazardous Energy Control (lockout/tagout).

15.4.2. Selected safety rules (two or three).

15.4.3. Methods and hazards of jobs in progress.

15.4.4. Unsafe practices and common causes of mishaps.

15.4.5. Recent accidents.

15.4.6. Potential personal injuries.

15.4.7. Personal Protective Equipment (PPE).

15.4.8. Electrical tools.

15.4.9. Materials handling.

- 15.4.10. Good housekeeping.
- 15.4.11. Adequate illumination.
- 15.4.12. Working on or near machinery.
- 15.4.13. Ladders.
- 15.4.14. Working in elevated positions.
- 15.4.15. Lifting and hoisting equipment, including aerial lifts.
- 15.4.16. Grounding systems.
- 15.4.17. Working in underground facilities (confined spaces).
- 15.4.18. Overhead lines.
- 15.4.19. First aid.
- 15.4.20. Rescue and resuscitation.
- 15.4.21. Arc Flash Hazards.
- 15.4.22. Hazards associated with working on or near energized lines or equipment.
- 15.4.23. Abnormal or hazardous existing conditions.
- 15.4.24. Equipment ratings (i.e. amp rating, interrupt rating, short circuit current rating (SCCR) and available interrupting current ratings (AIC)).
- 15.4.25. Energized work and the AF Form 1213, *Civil Engineer Energized Electrical Work Permit*.

### 15.5. Specific Job-Related Safety Training.

- 15.5.1. Supervisors must instruct employees who handle hazardous materials to include personal hygiene and protective measures in their safe handling of potential hazards. **(T-0)**. Supervisors must ensure Material Safety Data Sheets (MSDS) or Safety Data Sheets (SDS) are available for all hazardous chemicals according to AFI 90-821, *Hazard Communication (HAZCOM) Program*. **(T-0)**.
- 15.5.2. Supervisors must provide Hazard Communication training to employees who work on job sites where harmful plants or animals are present. **(T-0)**. Training must identify the potential hazards; explain how to avoid injury, include relevant first aid if an injury occurs. **(T-0)**.
- 15.5.3. Supervisors must instruct employees who enter confined or enclosed spaces on hazards and necessary precautions. **(T-0)**. Specific instructions and procedures to enter and work in hazardous or potentially hazardous confined spaces are consistent with the requirements in AFMAN 91-203, *Air Force Occupational Safety, Fire, and Health Standards*, and 29 CFR 1910.146, *Permit-required confined space*. Employees engaged in construction activities having one or more confined spaces must also comply with the requirements in 29 CFR 1926, *Safety and Health Regulations for Construction*. Technical orders or other procedures that incorporate the requirements established in the standard are valid and may be used. This training should also include egress even if the space is not confined.

15.5.4. Supervisors must ensure that employees are able to describe the work assignment and methods immediately before doing the work.

15.5.5. Arc Flash Safety Awareness Computer Based Training is required annually for 3E0X1, 3E0X2, 3E1X1, 3E4X1 Air Force Specialty Codes from the AFCEC Virtual Learning Center. **(T-3)**. This can be taken as a group and annotated in training records through your unit training manager.

**15.6. Assigning Tasks.** Supervisor's assign employees to jobs they are capable of doing safely. Permit only qualified personnel to operate equipment and machinery. Supervisors must ensure a minimum of two qualified employees work together when high-voltage circuits or energized circuits are present. **(T-0)**.

**15.7. Job Site Inspection.** Active job sites and materials must be inspected at a minimum once a day. Inspections throughout the day may be appropriate and necessary as determined by Supervisor and ensure unsafe items are tagged, rendered inoperative, or removed from the work site. Ensure safe working conditions and practices. Take action to correct any observed or reported violation of safety rules in this AFMAN. Pay particular attention to safe clearance procedures and practices when working on energized lines and equipment. Present safety briefings to workers at the job site.

**15.8. Mishap Reports.** Investigate every mishap involving an injury, property damage, or "near misses." Determine the cause and implement corrective action to prevent recurrence. Notify the wing or installation safety staff of all mishaps involving injuries or property damage. Investigate and report certain mishaps through safety channels according to AFI 91-204. Either the supervisor or base safety personnel will perform the initial investigation; however, the supervisor will still complete AF Form 978, *Supervisor Mishap Report*, as required. **(T-1)**.

**15.9. Standards and Codes.** Supervisors must train employees to comply with safety standards and the following codes: *National Fire Protection Agency (NFPA) 70®*, *National Electrical Code (NEC)®*; *NFPA 70E®*; *National Electrical Safety Code (NESC or American National Standards Institute (ANSI)®*; state, local, and host nation codes (see [Attachment 1](#)). **(T-0)**.

**15.10. Protective Equipment.** Supervisors must properly equip and train workers to properly use and maintain tools and PPE. **(T-0)**. Supervisors must ensure PPE is properly worn in accordance with additional guidance provided (see [Attachment 8](#)). Pay particular attention to rubber insulating protective equipment (rubber gloves, sleeves, line hoses, hoods, and covers) and hotline tools. Supervisors must make sure equipment receives periodic documented electrical tests in accordance with applicable ANSI and American Society for Testing and Materials (ASTM) specifications (see [Attachment 1](#)). **(T-0)**.

**15.11. Scheduling Routine Maintenance.** When routine maintenance requires disrupting power, schedule the outage for the least inconvenience to all users possible without jeopardizing the safety of workers or equipment. Arrange electrical circuits and equipment of the prime power source to allow safe and efficient performance of routine maintenance tasks with minimum mission impact as a result of the outage.

**15.12. First Aid Training.** Supervisors must ensure all electrical personnel (military and civilian) receive training in cardiopulmonary resuscitation (CPR), controlling bleeding, shock management, emergency care of a person having open wounds or burns, and using automated external defibrillators. **(T-0)**.

15.12.1. Host base medical personnel usually train unit CPR instructors. If the host base cannot provide medical personnel, they can arrange for certification of unit personnel through the American Red Cross or American Heart Association.

15.12.2. Personnel's certification shall be current according to American Red Cross or American Heart Association guidelines. **(T-0)**. Supervisors must maintain written documentation of current certification. **(T-1)**.

15.12.3. Supervisors must ensure relevant emergency phone numbers are readily available to all personnel. **(T-1)**.

**15.13. Rescue Training.** Supervisors must train individuals designated for rescuing workers from confined spaces according to Occupational Safety and Health Administration (OSHA) and Air Force occupational safety and health requirements to include blood borne pathogen training; this includes initial and annual refresher training. **(T-0)**.

**15.14. Noise Hazards.** Ensure all potentially hazardous noise sources are identified to bioenvironmental engineering services for evaluation. Ensure all personnel that may be exposed to noise hazards are made aware of them and use the controls required by AFI 48-127, *Occupational Noise and Hearing Conservation Program*. Supervisors will post noise hazard warning signs at noise hazard area entry points, to warn workers. **(T-0)**. Refer to AFMAN 91-203 and 29 CFR 1910.146 for additional information.

**15.15. System Maintenance.** Supervisors must ensure electrical systems are maintained so they continue to operate in a safe and effective manner in accordance with UFC 3-550-01, and UFC 3-520-01. **(T-0)**. Supervisors must not authorize or permit alterations or modifications to equipment or protective device settings without adequate engineering guidance and study. **(T-1)**. Supervisors must remove all obstacles and vegetation that restrict unimpeded egress from the work area or ready access to equipment. **(T-2)**.

**15.16. Technical Data.** Supervisors will ensure current maintenance and operations procedures, diagrams, schematics, device settings, fuse sizes, and manuals are available and properly used. **(T-0)**. Supervisors will develop them if manufacturers' data are not available; obtain engineering guidance if necessary. **(T-2)**. Accurate, current (typically five (5) years or less) electrical short circuit and coordination studies on the primary distribution system that includes facility transformers are necessary in order to further calculate and determine arc flash potentials, equipment ratings, and settings on downstream equipment within the facility.

**15.17. Supervisory Control and Data Acquisition (SCADA) Systems.** Comply with Air Force Guidance Memorandum (AFGM) 2019-32-02, *Civil Engineer Control Systems Cyber Security*. All operators of SCADA systems that remotely control electrical distribution systems must have full knowledge of the base distribution system and thorough understanding of switching procedures. **(T-1)**. Operators must keep each display screen (schematic or map) within the SCADA system up-to-date and all switching points on the remote terminal unit accurately identified. **(T-1)**. Supervisors will develop local written and posted procedures for remote operation of circuit breakers and switches to ensure safety of personnel and equipment. **(T-0)**.

**15.18. Safe Clearance.** Make sure all workers are thoroughly familiar with and comply with the most stringent safe clearance procedures found in NFPA 70E, AFMAN 91-203, or those posted at the job location before starting work. See [Chapter 17](#). Supervisors must not permit work unless workers follow these procedures. **(T-0)**.

**15.19. Work on Energized Equipment.** Work on energized electrical equipment is prohibited except in circumstances justified and approved by the BCE, or equivalent, in accordance with **Chapter 18. (T-1).**

**15.20. Routine Maintenance Outages.** Before de-energizing circuits or equipment for routine maintenance or repair, the BCE must:

15.20.1. Provide a minimum three-day notice to all users who may be affected by the electrical utility outage. **(T-1).** Facility manager approval is not required, but as a courtesy, an effort should be made to coordinate the outage.

15.20.2. Coordinate substation, switch station, or major feeder outages with the utility provider, giving as much advance notification as possible. **(T-1).**

15.20.3. Assist users with authorized backup power, either through equipment authorization inventory data or real property installed equipment generators. **(T-1).**

15.20.4. Prepare to run a backup generator during the outage if necessary. **(T-1).**

## Chapter 16

### POLYCHLORINATED BIPHENYLS (PCB)

**16.1. Purpose and Limitations.** PCB is a class of nonflammable liquid insulation formerly used as a transformer liquid dielectric. PCB is a suspected carcinogen and no longer manufactured. Several manufacturers distributed PCB under various trade names, such as Askarel, Inerteen, Pyranol, and Chlorextol.

**16.2. Personal Contact Precautions.** Workers should avoid contact with PCB. If PCB contacts the skin, remove it with waterless hand cleaner, wipe with towels, and dispose of towels with other contaminated material. If PCB contacts the eyes, thoroughly flush with water and seek medical attention.

**16.3. Cleaning Spills.** PCB spills shall be cleaned up immediately in accordance with 40 CFR 761.125, *Requirements for PCB spill cleanup. (T-0)*. Prevent PCB from reaching storm drains, sewers, drainage ditches, or any other place where water is flowing. Handle a PCB spill and report it according to base and Environmental Protection Agency (EPA) requirements. Report a spill through the base environmental coordinator.

**16.4. Controlling Equipment Containing PCB.** Mark, handle, store, dispose of, and account for equipment containing PCB according to the latest EPA standards and in accordance with 40 CFR 761 Subpart B and D. **(T-0)**. See AFI 32-7001, *Environmental Management*, for on base PCB waste management and recordkeeping requirements and contact the base CE environmental coordinator for additional information and the latest EPA rulings.

## Chapter 17

### SAFE CLEARANCE REQUIREMENT

**17.1. Safe Clearance Requirement.** Supervisors must require safe clearance procedures for personnel opening and closing switches while working on transmission or distribution lines and equipment. **(T-0).** Safe clearance procedures are necessary to clear lines and equipment for work in the de-energized condition. Safe clearance includes locking out switches, breakers, or other controlling devices when necessary. Mishap prevention tags, completing and posting energized work permits, and grounding provide additional warning and safety if lockout is not possible because of equipment design; however, if a circuit cannot be locked out, a qualified worker, as defined by NFPA 70 must remain at the controlling device while work is being conducted. **(T-0).** Supervisors must ensure no individual works on lines or equipment until all safety requirements are satisfied. **(T-0).**

#### 17.1.1. Safe Clearance Responsibilities.

17.1.1.1. The Safe Clearance Manager, who is designated by the BCE, will issue a written safe clearance as required and document on AF Form 269, *Electrical Facilities Safe Clearance*. **(T-0).** The Safe Clearance Manager will arrange for interruption of service, must have knowledge of the base distribution system, and notify the utility company supplying power to the installation before performing any operation that may affect the utility company's system. **(T-1).** An on-site supervisor may also perform the duty of Safe Clearance Manager or Switching Supervisor (person receiving safe clearance), but never both. The Safe Clearance Manager Switching Supervisor must never be one and the same (person receiving safe clearance, see [paragraph 17.2](#)). **(T-1).**

17.1.1.2. The Safe Clearance Manager will develop written and posted local procedures for proper switching, blocking, tagging, and lockout when switching by remote control, such as the SCADA system. **(T-0).** Depending on the type of SCADA system, each software manufacturer has different protocols to identify and issue tag orders for equipment or switchgear being worked on. The Safe Clearance Manager will ensure written procedures are available to an electrician and the SCADA operator in the event of a switching failure by SCADA requiring the technician to manually clear the switching failure. **(T-0).** Each worker and system operator must fully understand local procedures; local procedures must be accessible or available in the work area. Physically verify all SCADA-issued commands for opening and physically apply lockout before beginning work. **(T-0).** When working on equipment with local control capability, the technician must take control from the SCADA operator and notify the operator when the equipment is returned to normal operation. **(T-0).** The operator must issue blocking orders and attach messages stating the reason for the condition and estimated restoration time. **(T-0).**

**17.2. Switching and Blocking Procedures.** The Switching Supervisor (person receiving AF Form 269 from the Safe Clearance Manager) ensures workers accomplish switching, blocking, and tagging operations in the sequence specified on AF Form 269. Operations may begin only when authorized by the Safe Clearance Manager. When work is completed the system will be restored to normal operation in reverse order. For instance, if a detail of switching, blocking, and tagging reads, "Open Switch No. 501 and Attach Danger Tag," the opposite operation is "Remove Danger Tag and Close Switch No. 501." Annotate AF Form 269 with the date and time. Do not

operate switches bearing AF Form 979, *Danger Tag*, or AF Form 982, *Danger Tag: Do Not Start*, under any circumstances without specific authorization from the operations flight chief. Notify the SCADA systems operator before operating remotely operated or monitored circuit-opening devices. The "local-remote" switch must be blocked in the position which disables remote operation. The Switching Supervisor will notify the SCADA systems operator when work is complete and remote operation is safe. **(T-1)**. These switching and blocking procedures are only used only when following an approved AF Form 269 for primary distribution.

**17.3. Tagging Procedures.** "Tagging" is placing an appropriate tag directly on the circuit opening device. Apply tags and lock out the energy control device to ensure safety and prevent unauthorized personnel from altering device positions. A qualified technician will place danger tags in a conspicuous place upon opening a switch, disconnects, cutouts, primary jumpers, or breakers, before beginning work on a line or equipment. **(T-0)**.

**17.4. Underground Distribution Systems.** A qualified technician will block the switch mechanically and lock and tag the handle on underground distribution systems when it is not practical to provide a visible line break. **(T-1)**. A qualified technician will always use AF Form 979; AF Form 980, *Caution Tag*; AF Form 982, and AF Form 269, except when working on secondary lines or equipment. **(T-1)**. A qualified technician will not use AF Form 269 when applying AF Forms 979, 980, and 982 on secondary lines or equipment. **(T-1)**.

**17.5. Grounding Lines and Equipment.** Before touching for work, always check all de-energized transmission and distribution lines and equipment by testing for voltage. Confirm lines are grounded. Treat all lines which are not grounded as energized. For definitions of transmission and distribution-voltages, see [Attachment 1](#).

## Chapter 18

### ENERGIZED CIRCUITS

**18.1. Energized Circuits.** When energized work is deemed absolutely necessary, and approved by the BCE or equivalent, supervisors must ensure it is accomplished with extreme caution and only when the basic energized work procedures listed in the following paragraphs are followed and reviewed with all personnel immediately before starting. **(T-1)**. Furthermore, if any potential environmental, safety and health, operational, fiscal, or mission risks are associated with working on energized circuits, the BCE must notify and consult with the base/wing Staff Judge Advocate. **(T-1)**. Such risks may also create potential legal liabilities for the Air Force and Air Force personnel.

**18.2. Electrical Hand Holes.** Work on or near energized electrical lines in hand hole enclosures sized to allow personnel to reach into, but not enter, for the purpose of installing, operating, or maintaining equipment or wiring or both is prohibited because the available working space is too small for safe work practices. Supervisors must ensure all hand hole electrical circuits are completely de-energized before starting any troubleshooting, maintenance, or repair action within the hand hole. **(T-1)**.

**18.3. Low Voltage Electrical Panels.** Conventional circuit de-energizing/re-energizing methods (i.e., turning off/on a switch, opening and closing switches, or operating circuit breakers/disconnects) for the purpose of controlling an entire circuit is not considered performing energized work; however; supervisors must ensure the PPE requirements of UFC 3-560-01 are met. **(T-0)**. On a case-by-case basis, the BCE can grant written approval to waive the usage of the 8 Cal/cm<sup>2</sup> coverall requirement if a qualified electrical engineer has verified that the panel meets the parameters of [Table A8.1](#) to include all notes, and panel maintenance per NFPA 70E, Article 225, has been performed and documented.

**18.4. Electrical Manholes Containing Low-Voltage Circuits.** Electrical manholes containing low voltage are considered Permit Required. Work on or near energized electrical equipment in manholes containing low-voltage circuits is prohibited because of high arc flash currents for secondary circuits downstream of distribution transformers. Supervisors must ensure manholes that contain distribution-voltage but also share space for low-voltage electrical circuits are also completely de-energized before starting any troubleshooting, maintenance, or repair actions. **(T-1)**.

**18.5. Electrical Work Not In Manholes or Hand holes.** Work on or near energized electrical equipment is prohibited except in rare circumstances and then only when approved by the BCE or equivalent in accordance with the procedures outlined in the following paragraphs. Authorization is not required for tasks such as voltage measurement on circuits operating less than 600V as long as maintenance or repair is not performed, and safe practices and appropriate PPE are used. Safe practices and appropriate PPE are determined by the qualified site supervisor who must follow applicable UFC and NFPA 70E, Article 130 guidance. **(T-0)**.

18.5.1. The BCE must approve energized work in advance. **(T-0)**. Prepare an AF Form 1213 in accordance with UFC 3-560-01 and also include an emergency egress plan in the event of an emergency. The AF Form 1213 helps to ensure a qualified site supervisor has the information to ensure all work performed on or near energized lines greater than 600V is based

upon a risk management (RM) analysis in accordance with AFI 90-802, *Risk Management* and has been coordinated through the operations flight chief. A qualified site supervisor must deliver the final signed AF Form 1213 to the foreman or acting foreman or NCOIC of the electric shop to retain for a period of one year following completion of work. **(T-0)**.

18.5.2. Per UFC 3-560-01, energized work performed must be under the direct supervision of a qualified work leader devoting full time and attention to the workers and the safety of their work. **(T-0)**. A qualified site supervisor must ensure two-person teams are used to perform the work. **(T-0)**. The safety observer must be trained in CPR. **(T-0)**.

18.5.3. A qualified supervisor must be consulted and approve any plan to work on energized equipment and ensure proper use of PPE. **(T-0)**.

18.5.4. Place special emphasis on PPE and appropriate supervision. Proper supervision, training, and planning are paramount to ensure safety.

18.5.5. For work on or near energized distribution voltage greater than 600V while the job is in progress, an on-site supervisor must closely supervise the workers, checking them constantly to make sure they are in safe working positions, handling tools safely, and complying with the energized work permit. **(T-0)**.

**18.6. Electrical Work in Manholes Containing Distribution Voltage.** Electrical manholes containing distribution-voltage are considered Permit Required confined spaces. Work on or near energized electrical equipment in manholes is extremely dangerous and prohibited except when justified and approved; before entering a manhole containing distribution-voltage energized circuits, first visually confirm the manhole's installed configuration allows entry without disturbing any installed conductors or equipment. If it is not possible to enter the manhole without disturbing conductors, or if it is not possible to move around inside the manhole without disturbing conductors (adequate working space), then all circuits inside the manhole are de-energized before entry. The foreman or acting foreman or NCOIC of the electric shop must make the assessment regarding safe entry. **(T-1)**.

18.6.1. Inspection-Only Access in Manholes Containing Energized Circuits with No Known Problems. Inspection-type work can be authorized and is limited to allow a qualified employee to enter a manhole where energized cables or equipment are in service for the purpose of inspection, housekeeping, taking readings, or similar work, if such work can be performed safely. Safely entering a manhole for this purpose requires wear of minimum Arc Flash PPE Category 2 (NFPA 70E) and compliance with other confined space requirements in AFMAN 91-203. Inspection-only access, must be approved by the foreman or acting foreman or NCOIC of the electric shop. **(T-1)**. Up to one-half (0.5) inch of standing water is permitted for inspection activities so long as no conductors are present in the standing water. Qualified technicians must ensure measurements are taken with a non-conductive instrument from outside the manhole or hand hole. **(T-0)**. The energized work permit for "inspection-only access" can be discarded after the activity is complete.

18.6.1.1. Entering a manhole safely for the purpose of examining insulated cable, equipment, or accomplishing other inspections not requiring touching or disturbing the energized conductors or equipment is permitted, but requires wear of minimum Arc Flash PPE Category 2 (NFPA 70E) and compliance with other confined space requirements AFMAN 91-203.

18.6.1.2. A minimum of three qualified people are necessary for this activity. Qualification requirements are specified in UFC 3-560-01.

18.6.1.3. Supervisors will prepare an energized work permit in advance in accordance with UFC 3-560-01, and also include an emergency egress plan in the event of an emergency. **(T-0)**.

18.6.2. Work Inside Manholes Containing Energized Circuits. Electrical manholes containing energized circuits are considered Permit Required. Work other than inspection-only can be authorized in manholes that have a minimum of four (4) feet of working clearance in accordance with the following paragraphs, but is limited to: removing conduit plugs; spare conduit inspection using fish tape; borescope or other devices; splicing de-energized conductors; pulling new conductors in spare conduits; removing abandoned (de-energized) circuits, including load break or dead break elbows -- if nearby energized circuits are not disturbed. Re-racking energized conductors is not permitted. The circuits are de-energized before the conductors can be disturbed. Accomplishing this work when standing water is in the manhole is not permitted.

18.6.2.1. The BCE must approve energized work in advance. **(T-0)**. Prepare an energized work permit in accordance with UFC 3-560-01 and also include an emergency egress plan in the event of an emergency. The operations flight chief must ensure work performed inside a manhole containing energized circuits is accomplished based upon a risk management (RM) analysis in accordance with AFI 90-802 and coordinated through the operations flight chief. **(T-1)**. The RM analysis must be kept with the energized work permit and retained by the chief of the electrical shop for a period of one year following completion of work. **(T-1)**.

18.6.2.2. A minimum of three qualified persons is necessary for this activity. Qualification requirements are specified in UFC 3-560-01.

18.6.2.3. Supervisors will prepare an energized work permit in advance in accordance with UFC 3-560-01, and also include an emergency egress plan in the event of an emergency. **(T-0)**.

18.6.3. All Other Work Inside Manholes Containing Energized Circuits. Accomplishing this work where there is standing water in the manhole is not permitted. All other work in manholes containing energized circuits is considered Permit Required.

18.6.3.1. The BCE must approve energized work in advance. **(T-0)**. Prepare an energized work permit in accordance with UFC 3-560-01 and also include an emergency egress plan in the event of an emergency. **(T-0)**. The operations flight chief must ensure all other work performed inside a manhole containing energized circuits is accomplished based upon a RM analysis in accordance with AFI 90-802 and coordinated through the operations flight chief. **(T-1)**. The RM analysis must be kept with the energized work permit and retained by the chief of the electrical shop for a period of one year following completion of work. **(T-1)**.

18.6.3.2. Provide an information copy of signed energized work permit and RM analysis to the AFCEC/COSM.

18.6.3.3. Electrical analysis software packages that perform arc flash calculations do not account for an electrical manhole configuration in which the electrical worker is inside an enclosed area rather than standing adjacent to an enclosure. Increase the arc flash PPE requirements by a minimum of one (1) arc flash PPE category above the arc flash calculation result per UFC 3-560-01.

18.6.3.4. A minimum of three qualified people are necessary for this activity. Qualification requirements are specified in UFC 3-560-01.

**18.7. Electrical Manholes Containing Transmission-Voltage Circuits.** Work on or near energized electrical equipment in manholes containing transmission-voltage circuits is prohibited. Electrical work in manholes containing transmission voltage circuits using the procedures in the next sentence is considered a Permit Required confined space. A qualified technician must ensure all manhole electrical circuits are completely de-energized before starting any troubleshooting, maintenance, or repair action within the manhole. **(T-1).**

WARREN D. BERRY, Lt Gen, USAF  
DCS/Logistics, Engineering & Force Protection

**(USAFE-AFAFRICA)**

GEORGE T.M. DIETRICH III, USAF, Brigadier  
General  
Director of Logistics, Engineering and Force  
Protection

**Attachment 1****GLOSSARY OF REFERENCES AND SUPPORTING INFORMATION*****References***

7 CFR 1724.50, *Compliance with National Electrical Safety Code*, 1 January 2011

14 CFR 420.71, *Lightning Protection*, 1 January 2016

29 CFR 1910, *Electrical Standards – Final Rule*

19 CFR 1910.146, *Occupational Safety and Health Standards*

29 CFR 56.12069, *Lightning Protection for Telephone Wires and Ungrounded Conductors*, 29 January 1985

29 CFR 1910.146, *Permit-Required Confined Spaces*

29 CFR 1926, *Safety and Health Regulations for Construction*

40 CFR 761.125, *Requirements for PCB Spill Cleanup*

**(Added-USAFE-AFAFRICA)** ACE Directive 80-6, Volume 2, Part II/ED 60-12, *Nuclear Surety Management for the WS3*, 09 Dec 2015

**(Added-USAFE-AFAFRICA)** ACE Directive 80-6, Volume 2/ED 60-10, *Nuclear Surety Management*, 09 Dec 2015

**(Added-USAFE-AFAFRICA)** British Standard (BS) *EN 62305-1 / 4, Lightning Protection Standard*, 2011

**(Added-USAFE-AFAFRICA)** Bureau De Normalisation (NBN) C 18-100, *Code of Practice: Lightning Protective Systems*, 1985

**(Added-USAFE-AFAFRICA)** Bureau De Normalisation (NBN) *EN 62305-1 / 4, Protection Against Lightning*, 2012

**(Added-USAFE-AFAFRICA)** Comitato Elettrotecnico Italiano (CEI) *EN 62305-1 / 4, la protezione contro i fulmini*, 2013

**(Added-USAFE-AFAFRICA)** DAFI 33-360, *Publications and Forms Management*, 15 Dec 2018

**(Added-USAFE-AFAFRICA)** Deutsches Institut fuer Normen (DIN) *EN 62305-1 / 4, Protection Against Lightning*, 2011

DoD 6055.09M, Vol. 2, *DoD Ammunition and Explosives Safety*, April 2012

Department of Defense Explosives Safety Board Technical Paper 22 (DDESB TP-22), *Lightning Protection for Explosives Facilities*

**(Added-USAFE-AFAFRICA)** AFI 33-322, *Records Management and Information Governance Program*, 22 March 2020

**(Added-USAFE-AFAFRICA)** AFMAN 32-1065, *Grounding & Electrical Systems*, 17 July 2020

AFPD 32-10, *Installations and Facilities*, 4 March 2010

AFI 32-1062, *Electrical Systems, Power Plants and Generators*, 15 January 2015

AFI 32-7001, *Environmental Management*, 23 August 2019

AFI 48-127, *Occupational Noise and Hearing Conservation Program*, 26 Feb 2016

AFI 90-802, *Risk Management*, 1 April 2019

AFI 90-821, *Hazard Communication (HAZCOM) Program*, 13 May 2019

AFI 91-202, *US Air Force Mishap Prevention Program*, 24 Jun 2017

AFI 91-204, *Safety Investigation and Report*, 27 Apr 2018

AFMAN 91-201, *Explosives Safety Standards*, 21 March 2017

AFMAN 91-203, *Air Force Occupational Safety, Fire, and Health Standards*, 11 December 2018

AFGM 2019-32-02, *Civil Engineer Control Systems Cyber Security*, 5 Sep 2019

DNA-A-86-60, V1-3, *DNA EMP Engineering Handbook for Ground-Based Facilities*, 1986

**(Added-USAFE-AFAFRICA)** Espanola de Normalizacion (UNE) EN 62305-1 / 4, *Protection Against Lightning*, 2012

FC 4-218-01F, *Criteria For Precision Measurement Equipment Laboratory Design And Construction*, 28 October 2015

Federal Information Processing Standards (FIPS) Pub 94, *Guidelines on Electrical Power for ADP Installations*, 1983

IEEE STD 1100, *IEEE Recommended Practice for Powering and Grounding Electronic Equipment (Emerald Book)*, 2005

IEEE STD 1100-1999

IEEE STD 142, *IEEE Recommended Practice for Grounding for Industrial and Commercial Power Systems (Green Book)*, 2007

IEEE STD 446, *IEEE Recommended Practice for Emergency and Standby Power Systems for Industrial and Commercial Applications (Orange Book)*, 1995

IEEE STD 81, *IEEE Guide for Measuring Earth Resistivity, Ground Impedance, and Earth Surface Potentials of a Ground System*, 2012

**(Added-USAFE-AFAFRICA)** International Electro-technical Commission (IEC) 62305-1 / 4, *Protection Against Lightning*, 2011

MIL-HDBK-419A, *Grounding, Bonding, and Shielding for Electronic Equipment and Facilities*, 29 December 1987

NEC 250, *Grounding and Bonding*

NEC 250.52, *Grounding Electrodes*

NEC 250.3, *Application of Other Articles*

NEC Article 250.4(A)(1), *General Requirements for Grounding and Bonding, Grounded System, Electrical System Grounding*

**(Added-USAFE-AFAFRICA)** Nederlands Normalisatie-Instituut (NEN) *EN 62305-1 / 4, Protection Against Lightning*, 2012

NETA MTS, *Standard for Maintenance Testing Specifications for Electrical Power Equipment and Systems*, 2015, [www.netaworld.org/standards/ansi-neta-mts](http://www.netaworld.org/standards/ansi-neta-mts)

NFPA 70, *The National Electrical Code (NEC)*, 2017

NFPA 70E, *Standard for Electrical Safety in the Workplace*

NFPA 77, *Static Electricity*, 2019

NFPA 780, *Standard for the Installation of Lightning Protection Systems*, 2020

NFPA 99, *Health Care Facilities Code*, 2018

**(Added-USAFE-AFAFRICA)** Tuerk Standard (TS) *EN 62305-1 / 4, Protection Against Lightning*, 2012

UFC 3-460-03, *O&M: Maintenance of Petroleum Systems*, 10 November 2017

UFC 3-501-01, *Electrical Engineering*, 6 October 2015

UFC 3-520-01, *Interior Electrical Systems*, 6 October 2015

UFC 3-550-01, *Exterior Electrical Power Distribution*, 1 September 2016

UFC 3-560-01, *Operation and Maintenance: Electrical Safety*, 24 July 2017

UFC 3-575-01, *Lightning and Static Electricity Protection Systems*, 1 July 2012

UFC 3-580-01, *Telecommunications Interior Infrastructure Planning and Design*, 1 June 2016

### ***Prescribed Forms***

AF Form 269, *Electrical Facilities Safe Clearance*

AF Form 1213, *Civil Engineer Energized Electrical Work Permit*

**(Added-USAFE-AFAFRICA)** None.

### ***Adopted Forms***

AF Form 55, *Employee Safety and Health Record*

AF Form 847, *Recommendation for Change of Publication*

AF Form 978, *Supervisor Mishap Report*

AF Form 979, *Danger Tag*

AF Form 980, *Caution Tag*

AF Form 982, *Danger Tag: Do Not Start*

AF Form 983, *Danger Tag: Equipment Lockout Tag*

### ***Abbreviations and Acronyms***

A—Ampere

**ac**—Alternating Current  
**(Added-USAFE-AFAFRICA) ACE**—Allied Command Europe  
**AF/A4C**—Air Force Director of Civil Engineers  
**AFCEC/CO**—Air Force Civil Engineer Center, Operations Directorate  
**AFCEC/COSM**—Air Force Civil Engineer Center, Mechanical Engineering  
**AFI**—Air Force Instruction  
**AFMAN**—Air Force Manual  
**AFPD**—Air Force Policy Directive  
**AFSEC**—Air Force Safety Center  
**AHJ**—Authority Having Jurisdiction  
**AWG**—American wire gauge  
**BBF**—basic bonding formula  
**BCE**—Base Civil Engineer  
**BOS**—Base Operations Support  
**(Added-USAFE-AFAFRICA) BS**—British Standard  
**CATV**—Cable Television  
**cc**—Carbon Copy  
**CE**—Civil Engineering  
**(Added-USAFE-AFAFRICA) CE**—European Conformity  
**(Added-USAFE-AFAFRICA) CEI**—International Electro-technical Commission  
**DAC**—Defense Ammunition Center  
**(Added-USAFE-AFAFRICA) DAFI**—Department of the Air Force Instruction  
**dc**—Direct Current  
**DDESB TP**—Department of Defense Explosives Safety Board Technical Paper  
**ECM**—Earth-Covered Magazine  
**(Added-USAFE-AFAFRICA) ED**—United States European Command Directive  
**(Added-USAFE-AFAFRICA) EN**—European Norm  
**ETL**—Engineering Technical Letter  
**FC**—Facilities Criteria  
**FIPS**—Federal Information Processing Standard  
**ft**—Foot  
**HAS**—hardened aircraft shelter

**HVAC**—Heating, Ventilation, Air-Conditioning

**IAW**—In Accordance With

**IEEE**—Institute of Electrical and Electronics Engineers

**(Added-USAFE-AFAFRICA) JOI**—Joint Operating Instruction

**kA**—Kiloampere

**kV**—Kilovolt

**(Added-USAFE-AFAFRICA) LMF**—Local Monitoring Facility

**LOX**—liquid oxygen

**LPS**—Lightning Protection System

**MIL HDBK**—Military Handbook

**m**—Meter

**mm**—Millimeter

**(Added-USAFE-AFAFRICA) MUNSS**—Munitions Support Squadron

**(Added-USAFE-AFAFRICA) NBN**—Bureau De Normalisation

**NEC**—National Electrical Code

**(Added-USAFE-AFAFRICA) NEN**—Netherlands Normalisatie Institute

**NFPA**—National Fire Protection Association

**NETA MTS**—InterNational Electrical Testing Association Maintenance Testing Specifications

**ohms**—cm—Ohms Centimeter

**PAS**—Protective Aircraft Shelter (also known as Hardened Aircraft Shelter (HAS))

**POL**—petroleum, oils, lubricants

**(Added-USAFE-AFAFRICA) RMF**—Remote Monitoring Facility

**SABER**—Simplified Acquisition of Base Engineer Requirements

**SCIF**—Sensitive Compartmented Information Facility

**SDS**—separately derived system

**SOFA**—Status of Forces Agreement

**SPD**—Surge Protective Device

**(Added-USAFE-AFAFRICA) U.S.**—United States

**UAS/RPA**—Unmanned Aerial System/Remotely Piloted Vehicle

**UFC**—Unified Facilities Criteria

**UL**—Underwriters Laboratories

**(Added-USAFE-AFAFRICA) USAF**—United States Air Force

**(Added-USAFE-AFAFRICA) USAFE**—United States Air Forces in Europe

**Vac**—Volts Alternating Current

**V**—Volt

**WS3**—Weapon Storage and Security System

### *Terms*

**Air Terminal**—Alternate name for the device itself may be “lightning rod.” The component of a lightning protection system intended to intercept lightning flashes, placed on or above a building, structure, or tower. Note: A building’s grounded structural elements may function as an air terminal. A main size conductor run across the top of a pole or mast may also function as an air terminal if installed in such a way that the conductor across the top of the pole or mast is higher than the cradle in which it is run.

**Arc Flash Hazards**—Dangerous conditions deriving from the release of energy due to a phase-to-phase or a phase-to-ground fault.

**Blocking**—Placing a switch in the open or closed position and mechanically ensuring the position of the switch cannot be accidentally changed.

**Bonding**—An electrical connection between two electrically conductive objects, made with the intent of significantly reducing potential differences.

**Cable**—A conductor with insulation or a stranded conductor with or without insulation and other coverings (single conductor cable or a combination of conductors) insulated from one another (multiple conductor cable). Note: A cable sheath may consist of multiple layers of which one or more are conductive.

**Catenary System**—A lightning protection system consisting of one or more poles or masts with overhead wires between them. Each overhead wire may serve the function of both a strike termination device and a main conductor. Also known as overhead wire system.

**Circuit**—For purposes of this AFMAN, a conductor or system of conductors through which an electric current is intended to flow.

**Circuit Breaker**—A device to open and close a circuit and to open the circuit automatically at a predetermined overload of current, without injury to itself, when properly applied within its rating.

**Conductor**—Material (typically a wire, cable, or bus bar) for carrying an electric current. Note: This term is used only in reference to current-carrying parts that are sometimes energized.

**Conductor, Bonding**—A conductor used to bring the potential between two metallic objects to essentially zero.

**Conductor, Main**—A conductor intended to carry lightning currents from the point of interception to ground.

**Confined Space**—A space large enough and configured so a worker can bodily enter and perform assigned work; has limited or restricted means for entry or exit (for example: tanks, vessels, silos, storage bins, hoppers, vaults, manholes and pits); and is not designed for continuous human occupancy.

**Copper-Clad Steel**—Steel with a coating of copper bonded on it.

**Cross-tell**—Formal messaging system designed to share lessons learned and to disseminate new ideas or techniques between common users.

**Delta—wye**—transformer is a type of three-phase electric power transformer design that employs delta-connected windings on its primary and wye/star connected windings on its secondary.

**Down Conductor, Lightning**—The conductor connecting roof conductors of an integral system, overhead wires of a catenary system, or a mast system to the earth ground subsystem.

**Equipment Grounding Conductor**—The conductive path(s) that provides a ground-fault current path and connects normally non-current-carrying metal parts of equipment together and to the system grounded conductor or to the grounding electrode conductor, or both.

**Facility Ground System**—The electrically interconnected system of conductors and conductive elements that provides multiple current paths to earth. The facility ground system can include the earth electrode subsystem, lightning protection subsystem, signal reference protection subsystem, fault protection subsystem, static ground subsystem, as well as the building structure, equipment racks, cabinets, conduit, junction boxes, raceways, duct work, pipes, and other normally non-current-carrying metal elements.

**Frayed**—When the cross-sectional area of the wire or braid is reduced by half.

**Grounded (Grounding)**—Connected (connecting) to ground or to a conductive body that extends the ground connection.

**Grounding Electrode**—The portion of a lightning protection system, such as a ground rod, ground plate electrode, or ground conductor, that is installed for the purpose of providing electrical contact with the earth.

**Ground Loop Conductor**—A conductor, buried 3 to 8 feet (0.9 to 2.4 meters) from a structure, encircling the structure and interconnecting grounding electrodes. The conductor may also be connected to buried copper or steel plates or grounding electrodes which may have been installed to establish a low-resistance contact with earth. (A ground loop conductor is also referred to as a counterpoise, a loop conductor, or closed loop system.)

**Inherent Bond (Inherently Bonded)**—Where metal bodies located in a steel-framed structure are electrically bonded to the structure through the construction, either by configuration or by weight.

**Integral System**—A system which uses air terminals mounted directly on the structure to be protected. Note: integral systems protect both the structure and its contents.

**Labeled**—Equipment or materials to which has been attached a label, symbol, or other identifying mark of an organization that is acceptable to the AHJ and concerned with product evaluation, that maintains periodic inspection of production of labeled equipment or materials, and by whose labeling the manufacturer indicates compliance with appropriate standards or performance in a specified manner.

**Listed**—Equipment, materials, or services included in a list published by an organization that is acceptable to the AHJ and concerned with evaluation of products or services, that maintains periodic inspection of production of listed equipment or materials or periodic evaluation of services, and whose listing states that either the equipment, material, or service meets appropriate designated standards or has been tested and found suitable for a specified purpose.

**Lightning Rod**—See Air Terminal.

**Lightning Protection System**—A complete system of strike termination devices, conductors (which could include conductive structural members), grounding electrodes, interconnecting conductors, surge protective devices (SPD), and other connectors and fittings required to complete the system.

**Mast System**—A lightning protection system using masts that are remote from the structure to provide the primary protection from a lightning strike. A mast system may be a single mast or multiple masts.

**Non-Permit Confined Space**—A space that does not contain or, with respect to atmospheric hazards, have the potential to contain any hazards capable of causing death or serious physical harm

**Permit—Required Confined Space**—A confined space that has one or more of the following characteristics: contains or has a potential to contain a hazardous atmosphere; contains a material that has the potential for engulfing the entrant; has an internal configuration such that an entrant could be trapped or asphyxiated by inwardly converging walls or by a floor that slopes downward and tapers to a smaller cross-section; or contains any other recognized serious safety or health hazard.

**Premises Wiring System**—Interior and exterior electrical wiring of a building that extends from (a) the load end of the service drop or service lateral conductor to (b) the outlets; includes power, lighting, control, and signal circuit wiring in addition to all associated hardware, fittings, and wiring devices.

**Overhead Wire System**—System using conductors routed over the facility, at a specified height, designed to provide the required zone of protection. Also known as overhead shield wire system and catenary system.

**Side Flash**—An electrical spark, caused by differences of potential, that occurs between conductive metal bodies or between conductive metal bodies and a component of a lightning protection system or ground.

**Strike Termination Device**—A conductive component of the lightning protection system capable of receiving a lightning strike and providing a connection to a path to ground. Strike termination devices include air terminals, metal masts, wooden masts with an air terminal atop, permanent metal parts of structures, and overhead ground wires installed in catenary lightning protection systems. A main size conductor looped over the top of a wooden mast may also function as an air terminal.

**Structure**—(1) Metal-clad structure. A structure with sides or roof, or both, covered with metal. (2) Metal-framed structure. A structure with electrically continuous structural members of sufficient size to provide an electrical path equivalent to that of lightning conductors.

**Surge Protective Device (SPD)**—A device intended for limiting surge voltages on equipment by diverting or limiting surge current that comprises at least one nonlinear component.

**Tag**—A system or method of identifying circuits, systems, or equipment being worked on.

**Tagging**—Placing a safety tag directly on a circuit opening device or equipment for additional safety to ensure it is not used or its position altered.

**TEMPEST**—Unclassified name for investigation and study of compromising emanation.

**Third**—party Inspector – An inspector who is neither the designer nor the installer.

**Vac, VAC**—Volts, alternating current

**Voltage**—The effective root mean square (RMS) potential difference between any two conductors or between a conductor and ground. Voltages are usually listed as nominal values. The nominal voltage of a system or circuit is the value assigned to a system or circuit of a given voltage class to provide a convenient nomenclature. The operating voltage of the system may vary above or below this value:

- Low Voltage. Lines and equipment operating at and below 600 V (nominal phase-to-phase).
- High Voltage. Lines and equipment operating above 600 V (nominal phase-to-phase).
- Secondary Voltage. Lines and equipment operating at and below 600 V (nominal phase-to-phase).
- Distribution- Voltage. Lines and equipment operating above 600 V (nominal phase-to-phase) up to and including 36 kV (nominal phase-to-phase).
- Transmission Voltage. Lines and equipment operating above 36 kV (nominal phase-to-phase).

**Zone of Protection**—The space adjacent to a lightning protection system that is substantially immune to direct lightning flashes.

## Attachment 2

## SCHEDULED MAINTENANCE FOR GROUNDING SYSTEMS.

**A2.1. (Added-USAFE-AFAFRICA) Additional Information.** The following information is added to **Table A2.1** of the basic instruction for USAFE-AFAFRICA Scheduled Maintenance for Grounding Systems:

**Table A2.1. Schedule for Maintenance for Grounding Systems.**

Facility or System	Action Required	Frequency of Action	Responsible Organization	Reference	Comments	Wavier Authority
1. Exterior Electrical Distribution	a. Visual inspection of electrical distribution equipment fencing, pole grounds, pad-mounted equipment grounds, and neutrals.	5 years	BCE	UFC 3-501-01, <i>Electrical Engineering</i> UFC 3-550-01	<p>1. Any and all inspections should follow NETA MTS guidance</p> <p>2. It is not necessary to perform the 5-year inspection of the system in a single year; however, at the end of 5 years, documentation must show that the entire system has been inspected.</p> <p>3. If utility is privatized, this does not apply; however, safety and operational discrepancies and damage should be reported when observed.</p>	T-2
	b. Physical continuity of grounds for separately derived systems	2 years	BCE	This AFMAN	Ensure ring currents are not established by the existence of grounds for multiple systems and equipment.	T-2

2. Electrical substation <sup>1</sup> (if base-owned or totally/partially maintained by the base)	a. Continuity check across gate opening (1 ohm or less)					T-0
	b. Ground resistance measurement of entrance gate (5 ohms or less)	5 years	BCE	NETA MTS		T-0
3. Exterior lightning arrestors and/or surge protective devices on primary distribution lines (even if privately owned).	Visual	3-5 years Critical systems 1-3 years Upon revisions to a facility	BCE		Ensure reliability to the Air Force mission. Discrepancies should be reported, in writing, to the owner if other than Air Force, with cc to BCE	T-3
4. General	a. Facility service entrance - visual inspection	When electrical or communications work is performed at facility service	BCE	NFPA 70 (NEC), Art. 250 NFPA 70 (NEC), B UFC 3-575-01	Tag or mark in a conspicuous place to indicate visual inspection date and initials of inspector	T-3
	b. Verify bonding of other systems to facility grounds	Upon new installation, installation or upgrade of other systems requiring grounding, and prior to contract acceptance	BCE	NFPA 70 (NEC)	Ensure the integrity of the single point facility ground	T-0

	c. Visual inspection of lightning protection system and Surge protective devices	1-2 years, as determined by the base AHJ, based on facility type.	BCE	This AFMAN NFPA 780 UFC 3-575-01 UFC 3-520-01	Note mechanical damage, lightning damage, or discrepancies caused by repair, renovation, or addition	T-3
	d. Facility ground resistance check (per NEC Article 250, 25 ohms or less at service grounding electrode)	5 years	BCE	This AFMAN		T-3
5. POL facilities	a. Resistance measurement on static grounds (10,000 ohms or less)	Upon installation and when observed to be physically damaged	BCE	UFC 3-460-03, <i>O&amp;M: Maintenance of Petroleum Systems</i>		T-1
	b. Visual inspection and mechanical check of ground conductor connections (pull test)	Quarterly and when damaged  Annually	User  BCE	UFC 3-460-03		T-1

	c. Inspection of connection to grounding electrode	Annually for other than thermal weld. If thermal weld, inspect upon installation and when damaged.	BCE	UFC 3-460-03		T-1
	d. Facility service entrance - visual inspection	When electrical work is performed at facility, including destructive inspection and any kind of electrical testing, by other than BCE	BCE	NFPA 70 (NEC), Art. 250 NFPA 70 (NEC), B	Tag or mark in a conspicuous place to indicate visual inspection date and initials of inspector	T-0
6. Fuels lab	a. Visual inspection and continuity validation of equipment grounds	Monthly	User	AFMAN 91-203	BCE requirements are covered in Item 4, general facilities.	T-2
	b. Visual inspection of facility grounds	Monthly	User	AFMAN 91-203	BCE requirements are covered in Item 4, general facilities.	T-2
7. Aircraft parking apron grounds and hangar floor static grounds	Resistance measurement on static grounds (10,000 ohms or less)	When installed or repaired	BCE	UFC 3-575-01		T-1

8. LOX storage	Resistance measurement on static ground (10,000 ohms or less)	When installed, physically damaged, or repaired	BCE	This AFMAN		T-2
9. Rail car off-loading spur	Visual inspection of rail bonding	Annually (If the rail car enters an explosive facility, test for continuity every 2 years)	BCE	This AFMAN		T-2
10. Communications (& TEMPEST) Facilities	Ground resistance measurement at service entrance (Per NEC Article 250, 10 ohms or less at the service grounding electrode is design objective. If 10 ohms cannot be obtained after compliant installation of a ground loop, resistance is recorded as is.)	Quarterly for first year after installation; then every 21 months (see Note for this item)	BCE	NFPA 70 (NEC) This AFMAN	Communications facilities require tiered surge suppression – protection at the main distribution panel and any sub-panel serving sensitive communication s equipment, Heating, ventilation, and air conditioning, and at communication s equipment. <b>Note:</b> User has requested 21 months in order to comply with their references. User is responsible for trend analysis.	T-0

11. Communications Equipment	Checks involving in-house electronic equipment ground	Determined by user from T.O. and equipment manufacturer	User	Military-Handbook 419A, <i>Grounding, Bonding, and Shielding for Electronic Equipment and Facilities</i>	To prevent the effects of transients/surges on the electrical distribution, communications equipment contracts should include SPDs on the load sides of sub-panels. If surge protective devices are required by the equipment manufacturer, this is to be purchased and installed as part of the project.	T-3
12. Hazardous <sup>2</sup> explosives area (weapons)	a. Visual inspection of static bus bars, grounding conductors, and bonds	Before using equipment and every 6 months	User	AFMAN 91-201 This AFMAN NFPA 780, Ch. 8	Explosives area governed by DDESB	T-3
		Annually for nuclear facilities	BCE			T-0
	b. Resistance to ground for equipment bonding straps (10,000 ohms or less)	When physically damaged or when frayed from use	User	AFMAN 91-201		T-3
c. Continuity across bonds,	When physically damaged	User	AFMAN 91-201		T-3	

	between bus bars, conductors, and bonding straps (less than 1 ohm)	After system modification	BCE	NFPA 780, Ch. 8	Explosives area governed by DDESB	T-0
	d. Facility ground resistance check (per NEC Article 250, 25 ohms or less at service grounding electrode)	When repair or renovation is made to the facility	BCE	NFPA 70 (NEC)  This AFMAN	Explosives area governed by DDESB	T-0 Per NEC  T-1 for repair or renovation
	e. Conductive floor grounding check	Upon installation and when damage is reported	BCE	AFMAN 91-201 NFPA 780, Ch. 8	Explosives area governed by DDESB	T-1
	f. Visual inspection of SPDs	6 months and after a lightning strike	User	AFMAN 91-201 This AFMAN	Visual inspection may consist only of checking for an indicator lamp, denoting SPD operation  Explosives area governed by DDESB	T-3
		Annually	BCE			T-0
	g. See nonhazardous explosives requirements 13e, 13f, 13g, and 13i	This block is intentionally blank	This block is intentionally blank	This block is intentionally blank		
13. Non-hazardous <sup>2</sup>	a. Visual inspection of	Semi-annually	User	AFMAN 91-201	Intent of “semiannually” is	T-3

explosives area (weapons)	static bus bar, conductor, and bonds	Annually	BCE	NFPA 780, Ch. 8	every 180 days, $\pm 10$ days  Explosives area governed by DDESB	T-0
	b. Resistance to ground for equipment bonding straps (10,000 ohms or less)	When physically damaged or when frayed from use	User	AFMAN 91-201	Explosives area governed by DDESB	T-3
	c. Continuity check from equipment to static bus bar (1 ohm or less)	When physically damaged	User	AFMAN 91-201 NFPA 780, Ch. 8	Explosives area governed by DDESB	T-0
	d. Facility ground resistance check (Per NEC Article 250, 25 ohms or less at facility grounding electrode)	24 months	BCE	NEC This AFMAN AFMAN 91-201 NFPA 780 AHJ	Explosives area governed by DDESB	T-0
	e. Visual inspection of lightning protection system components	12 months	BCE	NEC AFMAN 91-201 This AFMAN NFPA 780 AHJ	AFMAN 91-201 refers to this AFMAN  Explosives area governed by DDESB	T-0

f. Ground resistance measurement on LPS at grounding electrode (per NEC Article 250, 25 ohms maximum) measured diagonally opposite to electrical service	24 months	BCE	NEC AFMAN 91-201 This AFMAN NFPA 780 AHJ	AFMAN 91-201 refers to this AFAMN  Explosives area governed by DDESB	T-0
g. Continuity validation on air terminals, bonds, and conductor connections (1 ohm or less)	24 months	BCE	AFMAN 91-201 This AFMAN NFPA 780 AHJ	Explosives area governed by DDESB	T-0
h. Visual inspection of SPDs	6 months and after a lightning strike	User	AFMAN 91-201	Visual inspection may consist only of checking for an indicator lamp, denoting SPD operation	T-2
	Annually	BCE	This AFMAN NFPA 780 AHJ	Explosives area governed by DDESB	T-0
i. Static bus bar continuity to ground (1 ohm or less)	24 months	BCE	AFMAN 91-201 This AFMAN NFPA 780 AHJ	Explosives area governed by DDESB	T-0

14. Protective aircraft shelter <sup>3</sup> vault	a. Facility single point ground system resistance check	At construction and every 24 months	BCE	This AFMAN	Governed by DDESB	T-0
	b. Visual inspection of grounding system	12 months	BCE	This AFMAN	Governed by DDESB	T-0
	c. Continuity between arch and ground (1 ohm or less)	At construction and every 24 months	BCE	This AFMAN	Governed by DDESB	T-0
	d. (HAS.) Validate door hinge continuity (1 ohm or less)	24 months	BCE	This AFMAN	Governed by DDESB	T-0
	e. (HAS) Continuity between vault lip (flange) and ground (steel conduit) (1 ohm or less)	At construction and every 24 months	BCE	This AFMAN	Governed by DDESB	T-0
	f. Continuity of installed (permanent) bonds between metal masses and steel support	When notified of damage	BCE	This AFMAN	Governed by DDESB	T-0

	g. Visual inspection of permanent bonds between metal masses and steel support	Annually	BCE	This AFMAN	Governed by DDESB	T-0
15. Medical facilities <sup>4</sup>	a. Ground resistance validation (Per NEC Article 250, 25 ohms or less at service grounding electrode)	5 years	BCE	NFPA 99, <i>Health Care Facilities</i>		T-3
	b. Effectiveness of grounding system by voltage and impedance measurements	Before acceptance of new facility or after service entrance modification	BCE	NFPA 99		T-0
	c. Verification of continuity of receptacle grounding circuits	Annually (semi-annually for critical care areas defined in NFPA70, hospitals and surgical centers)	BCE	NEC		T-0

16. Airfield lighting vault single point facility ground	Ground resistance check (Per NEC Article 250, 25 ohms or less)	2 years	BCE	This AFMAN		T-2
17. EMP hardened facilities	These facilities may have special requirements otherwise, resistance check (Per NEC Article 250, 25 ohms or less at service grounding electrode)	2 years	User	DNA-A-86-60, Vol 1-3, <i>DNA EMP Engineering Handbook for Ground-Based Facilities</i> This AFMAN		T-3
			BCE			T-2
18. PMEL	a. Visual inspection of equipment bonds	Before each use	User	This AFMAN		T-3
	b. Continuity and resistance test of facility ground (Per NEC Article 250, 10 ohms or less at service grounding electrode)	5 years	BCE	This AFMAN	Facility Criteria 4-218-01F, <i>Criteria For Precision Measurement Equipment Laboratory Design And Construction</i>	T-2
19. Special intelligence, cyber, SCIF,	a. TBD by AHJ	This block is intentionally blank	BCE	This block is intentionally blank		

UAS/RPA, launch and space, and other special-use facilities <sup>4</sup>	b. TBD by AHJ	This block is intentionally blank	User	This block is intentionally blank		
20. Surge protective devices	a. Visual inspection	After unscheduled power outages (report outage to BCE)	User	This AFMAN NFPA 780	User is onsite. A quick check and report to BCE may avoid additional damage until BCE can arrive.	T-0
	b. Visual inspection	After unscheduled power outages and annually	BCE	This AFMAN NFPA 780		T-0
<p>1. If utility is privatized, this does not apply; however, safety and operational discrepancies and damage should be reported when observed.</p> <p>2. As defined in NEC Article 500.</p> <p>3. Also known as hardened aircraft shelter (HAS), as determined by current Security Forces AFIs.</p> <p>4. BCE will perform if separate medical facility maintenance branch does not exist, under memorandum of agreement only.</p> <p>5. T-0 requirements for explosives facilities and PAS/HAS is delegable from DDESB to AFCEC/COSM.</p> <p>6. Where decision authority is the “Authority Having Jurisdiction” or “AHJ”, the Base Civil Engineer is considered the AHJ.</p> <p><b>Note:</b> All incoming utility services should be verified for continuity of grounding and bonding by the service provider every 5 years (i.e., gas, telephone, signal lines, CATV), including government-owned facilities systems.</p>						

**Table A2.1. (USAFE-AFAFRICA) Scheduled Maintenance for Grounding Systems.**

<b>Facility or System</b>	<b>Action Required</b>	<b>Frequency of Action</b>	<b>Responsible Organization</b>	<b>Reference</b>	<b>Comments</b>	<b>Waiver Authority</b>
21. <b>(Added)</b> Local Monitoring Facility (LMF), Remote Monitoring Facility (RMF), Command Post (CP) and Alternate Command Post (Alt CP) and other added under <b>Paragraph 12.7.</b>	a. LPS and Ground system resistance check (10 ohms maximum)	12 Months	Base Civil Engineer or Host Nation	IEC 62305-3, Table E.2		T-0
	b. LPS and Ground System visual inspection	6 Months	Base Civil Engineer, MUNSS Personnel or Host Nation	IEC 62305-3, Table E.2		T-0
22. <b>(Added)</b> Protective Aircraft Shelter vault (PAS)	a. LPS and Ground system resistance check (10 ohms maximum)	12 Months	Base Civil Engineer or Host Nation	IEC 62305-3, Table E.2		T-0
	b. LPS and Ground System visual inspection	6 Months	Base Civil Engineer, MUNSS Personnel or Host Nation	IEC 62305-3, Table E.2		T-0

### Attachment 3

#### BASIC REQUIREMENTS FOR GROUNDING SYSTEMS

**A3.1. Types of Grounds.** There are five basic types of grounding systems which must be inspected if present in a facility: static grounds, equipment grounds, electrical system grounds, lightning grounds (down conductors), and signal reference grounds. **(T-0).** Subsystem grounds is a hybrid of these five basic systems.

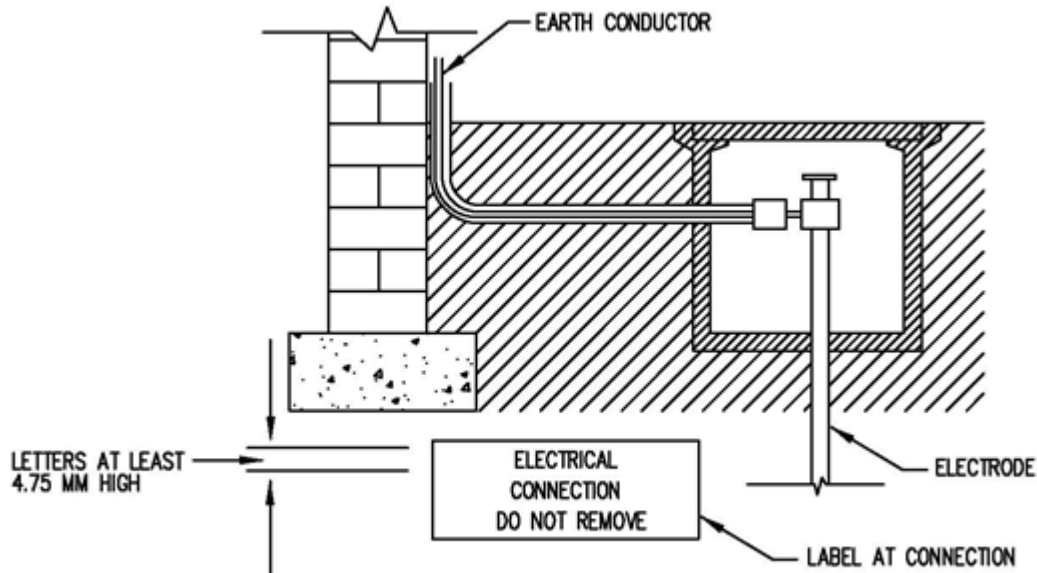
A3.1.1. Static Grounds. A static ground is a connection between a piece of equipment and earth to drain off static electricity charges before they reach a sparking (discharge) potential. Typically, static grounding involves connecting large metal objects such as fuel tanks or aircraft to earth through a grounding electrode. Static grounds are not part of an electrical power system, but if an equipment grounding conductor is adequate for power circuits it is also adequate for static grounding.

A3.1.2. Equipment Grounds. Equipment grounding involves interconnecting and connecting to earth all non-current-carrying metal parts of an electrical wiring system and equipment connected to the system. The purpose of grounding equipment is to ensure personnel safety by reducing any residual charge in an equipment item to near zero volts with respect to ground. An equipment ground must be capable of carrying the maximum ground fault current possible without causing a fire or explosive hazard until the circuit protective device clears the fault. An example is the bare copper wire or green insulated conductor connected to the frames of electric motors, breaker panels, and outlet boxes. The equipment ground is connected to an electrical system ground (neutral) only at the electrical service entrance of a building.

A3.1.3. Electrical System Ground (Single Point Facility Ground). The purpose of electrical system grounds is to limit the voltage imposed by lightning, line switching surges, or unintentional contact with higher-voltage lines and to stabilize the voltage to earth during normal operation. See NEC Article 250.4(A)(1). One wire or point of an electrical circuit in an electrical system ground is connected to earth. This connection is usually at the electrical neutral (though not always), and is called the "system ground" or "single point facility ground." The resistance of most electrical system ground electrodes operating at or below 600 Vac should not be more than 25 ohms. Medium voltage systems (1 to 15kV) frequently are grounded through a resistor (or reactor) and may exceed 25 ohms. This practice limits ground fault current to a manageable level. If a ground loop conductor functions as the electrical system ground (single point facility ground) then 25 ohms is not a requirement.

A3.1.4. Lightning Grounds or Down Conductors. The purpose of a lightning protection system is to provide for the safeguarding of persons and property from hazards arising from exposure to lightning. Grounds and down conductors are necessary to safely dissipate lightning strikes into the earth. They are part of a lightning protection system that usually includes air terminals (lightning rods), main size conductors, arrestors, and other connectors or fittings required for a complete system. It is helpful to provide test wells for access to the grounding electrodes to test for continuity to the down conductor.

**Figure A3.1. Test Well Configuration Example.**



A3.1.5. Signal Reference Grounds. The purpose of a signal reference ground is to provide a low impedance reference system for electronic equipment to minimize noise-induced voltages (distortions on the voltage waveform) and thereby reduce equipment malfunctions. Common configurations include planes and grids. See IEEE STD 1100-1999 *Recommended Practice for Powering and Grounding Electronic Equipment*, for details. With the exception of the connection point to the facility grounding system, the responsibility for individual signal reference ground testing lies with the equipment owners.

A3.1.6. Subsystem Grounds. Each of the grounding systems described above may be a subsystem of a total facility grounding system. All grounds (and subsystems) must be bonded together according to NFPA 780 and the NEC. The electrical system ground (single point facility ground) is the master ground and all must be tied to that point, either directly or indirectly. **(T-0)**. Testing of equipment grounds is the responsibility of the equipment owners.

**A3.2. NEC Grounding Requirements.** Electrical systems and circuit conductors are grounded to limit voltages during lightning and to facilitate overcurrent device operation in case of a ground fault. The NEC allows the system neutral to be grounded and limits the location of this neutral (NEC Article 250-24 and Exhibit 250.1). Since the neutral will carry current under normal operating conditions, the NEC refers to it as the grounded conductor. See NEC Article 250.

A3.2.1. Facility Ground. The NEC requires a premises wiring system to have a grounding electrode at each service. This electrode may be of several different types or systems. Each of the types listed below must be bonded together to form the grounding electrode system. **(T-0)**.

A3.2.1.1. Where a metal underground water pipe (uncoated) is in direct contact with the earth for 10 feet (3.05 meters) or more, do not bond around insulation flanges installed for cathodic protection. If the underground water pipe is the only electrode available, grounding electrodes must supplement it.

A3.2.1.2. The metal frame of a building where the building is effectively grounded.

A3.2.1.3. An electrode encased by at least 2 inches (51 millimeters) of concrete, made of at least 20 feet (6.1 meters) of one or more steel reinforcing bars, located within and near the bottom of a concrete foundation or footing in direct contact with the earth. This is known as a Ufer ground.

A3.2.1.4. A ground ring encircling the building at least 2.5 feet (0.76 meters) deep. The ground ring must be at least 20 feet (6.1 meters) long and use at least AWG No. 2 copper (for lightning protection ground ring conductor, see [paragraph A5.1.16](#)). **(T-0)**. Where none of the above-listed electrodes are present, grounding electrodes or ground plates must be used. **(T-0)**. Grounding electrodes must be at least 8 feet (2.44 meters) in length (10 feet (3.05 meters) for lightning protection; see [paragraph A5.1.11](#)). **(T-0)**. Grounding electrodes or plates must not be aluminum. **(T-0)**. The Air Force discourages the use of stainless-steel grounding electrodes because of the cost; however, they are allowed if the specific situation warrants their use.

A3.2.2. Separately Derived System (SDS). A separately derived system is an electrical source, other than a service, having no direct connection(s) to circuit conductors of any other electrical source other than those established by grounding and bonding connections. Examples of SDSs include generators, batteries, converter windings, transformers, and solar photovoltaic systems, provided they have no direct electrical connection to another source. The grounded circuit conductors are not intended to be directly connected.

A3.2.2.1. Dry type transformers (isolation and non-isolation) are common sources of SDSs in a facility. Typically, they are connected in a delta-wye configuration. SDS transformers are widely used in sensitive electronic installations (computer power distribution centers are essentially SDS transformers) since they effectively establish a local ground at the electronic equipment. This minimizes the impedance to ground as seen by the load. They should always possess a means of vibration isolation.

A3.2.2.2. Standby or emergency generators are also common sources of separately derived systems. A generator connected to a facility through a transfer switch is not a separately derived system if the neutral conductor remains connected to the normal commercial power source neutral after transfer (the neutral is not switched along with the phase conductors). AFI 32-1062, *Electrical Systems, Power Plants and Generators*, requires a switched neutral in the case of all real property installed equipment (RPIE) generators (4-pole generators and automatic transfer switches). For older generators without a switched neutral, the required connection of the neutral to the facility's grounding electrode system for both the commercial power source and the generator must be made only on the supply side of the commercial power service disconnect. **(T-0)**. Providing an additional connection between the generator neutral and a grounding electrode at the generator would be a grounding connection on the load side of the service disconnect and a violation of the NEC. Refer to IEEE Standard 446, *Recommended Practice for Emergency and Standby Power (The Orange Book)*, for additional information and requirements on grounding emergency and standby generators.

### A3.3. Grounding Electrodes.

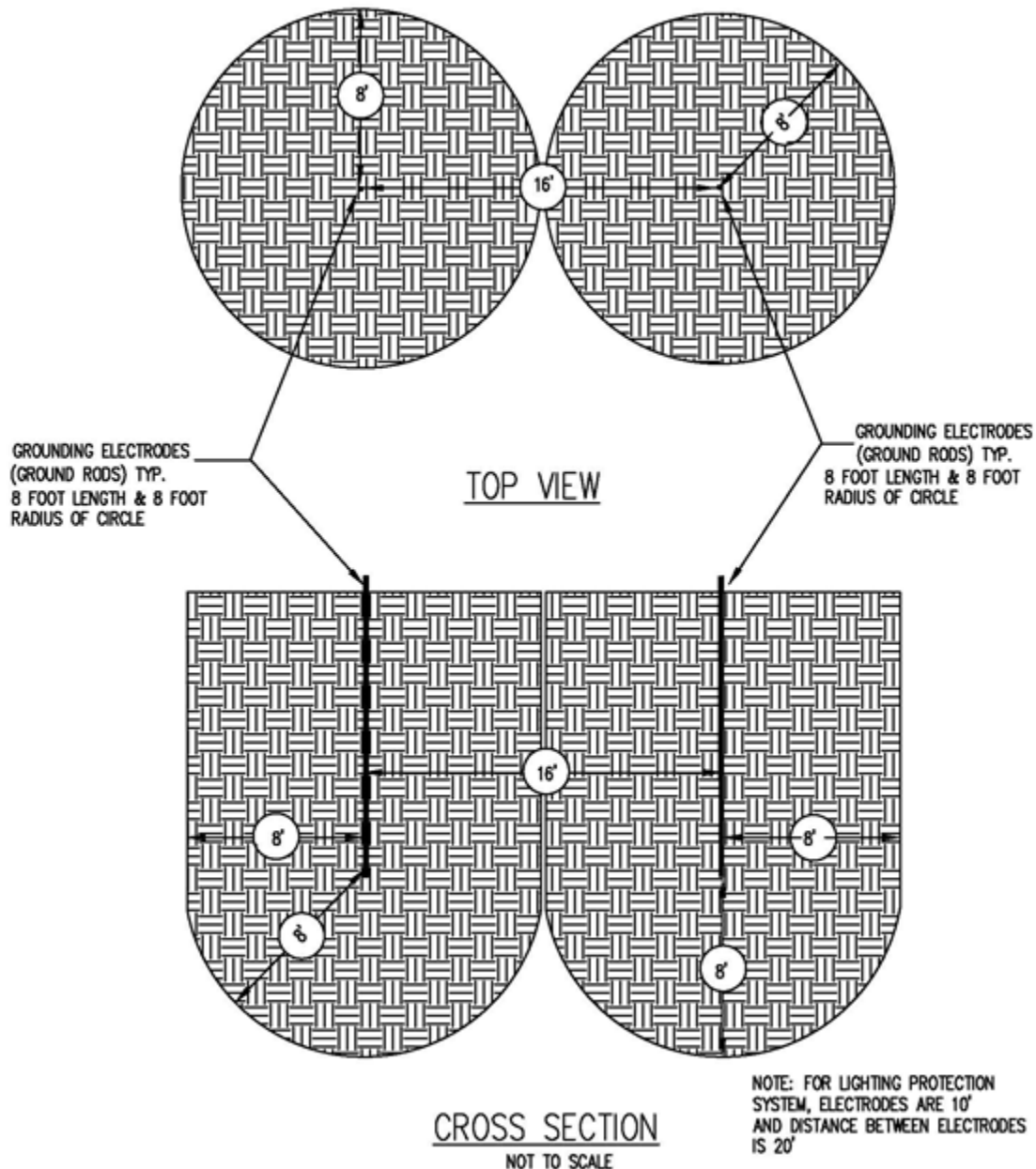
A3.3.1. Connection to Earth. The most practical method of connecting to earth is to bury a solid body, such as a metal rod, pipe, or sheet, and connect a grounding conductor to it. This solid body is known as a grounding electrode.

A3.3.2. Methods for Obtaining Better Grounds. Frequently a satisfactorily low electrode resistance cannot be obtained because of high soil resistivity. Use the following methods if it is necessary to lower the resistance of the electrode.

A3.3.2.1. Deeper Grounding Electrode (Ground Rod). As a grounding electrode is driven more deeply into the soil, it not only has more surface contact with the earth, but it also begins to reach soil which is more conductive. The deeper the electrode, the less the effect of poor surface moisture content and temperature changes.

A3.3.2.2. Parallel Grounding Electrodes. Grounding electrodes driven parallel to each other should have space between them at least the length of the electrodes unless only a few additional ohms are required to obtain 25 ohms. In that case, the additional electrode may need to be only a few feet from the first driven electrode. To determine necessary distance prior to permanently placing the second ground rod, partially drive the ground rod, attach a temporary bond between the two, and re-measure the resistance of the combination. If 25 ohms is achieved, remove the temporary bond, drive the ground rod in place and permanently bond the two together. Multiple electrodes connected by a conductor have a greater ability to equalize potential over the installation area.

**Figure A3.2. Parallel Grounding Electrodes at Service Entrances (Also See NEC Minimums).**

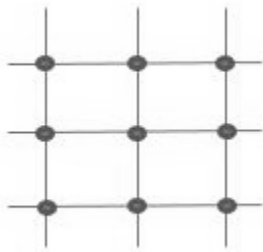


A3.3.2.3. Soil Replacement. You can significantly lower the resistance of a grounding electrode by lowering the resistivity of the soil immediately surrounding it. Use a mixture of 75 percent gypsum, 20 percent bentonite (well driller's mud), and 5 percent sodium sulfate. This mixture is available from cathodic protection supply companies. The mixture is better than chemical salts because it lasts much longer and chemical salts may not be compatible with environmental requirements. Various vendors provide low-resistance backfills that may be approved on a case-by-case basis. In all instances, indication should be less than 5 percent sulphur content.

A3.3.2.4. Concrete Encapsulation. Encapsulating grounding electrodes with concrete increases their effective diameter. The concrete absorbs water from the soil, increasing the conductivity directly around the electrode.

A3.3.2.5. Other Methods. Other more-elaborate methods include installation of a ground loop conductor, electrode networks, or multiple electrodes laid horizontally both parallel and perpendicular, and bonded together to create a grid about 18 inches (0.5 meter) below the surface.

**Figure A3.3. Sample Grid of Bonded Horizontally Laid Grounding Electrodes.**



**A3.4. Grounding and Corrosion.** Copper grounding has been the standard of the electrical industry almost from inception. Because copper is cathodic to all common construction materials, corrosion often results when copper is in contact with ferrous structures. Bonding underground ferrous structures to copper grounding systems can create serious corrosion problems.

A3.4.1. Corrosion of Pipelines. A typical situation for corrosion development exists when a facility's copper grounding system is bonded to a coated steel pipeline entering the facility. If this pipe is installed in low-resistivity soil, corrosion current will be high because of the potential between copper and steel, the low-resistance circuit, and concentrated at the voids in the pipe coating. Common solutions to this problem are use of galvanized steel rather than copper grounding electrodes, installing an insulating fitting above the ground in the pipeline where it exits the soil and as it enters the building, separating the grounding system and the piping systems as widely as possible, installing a sacrificial anode system, or some combination of these solutions. Note that while the aboveground portion of the pipeline is grounded for safety, the underground portion is already grounded by contact with the soil. The resistance to earth of a typical coated piping system is usually 1 to 5 ohms.

A3.4.2. Hazardous Voltages. If insulating fittings are installed on a pipeline, take precautions against lightning flashover at the fittings or a dangerous potential difference between the pipe sections. Connect a metal oxide varistor (MOV) lightning arrestor, zinc grounding cell, or an electrolytic cell across the insulating device. The clamping voltage should be 3.14 times the maximum output voltage of the rectifier of the cathodic protection system.

A3.4.3. Zinc Grounding Cell. A zinc grounding cell is made of two bars of 1.4 by 1.4 by 60-inch (3.55 by 3.55 by 152.4-centimeter) zinc separated by 1-inch (2.54-centimeter) spacers. Each bar has an insulated AWG No. 6 stranded copper conductor silver-brazed to a 0.25-inch (0.64-centimeter) -diameter steel core rod. The unit comes prepackaged in a bag of low-resistivity backfill (75 percent gypsum, 20 percent bentonite, 5 percent sodium sulfate). The nominal resistance of a two-anode grounding cell is 0.4 ohm. For lower resistance, a four cross-

connected zinc anode cell with a resistance of 0.2 ohm is available. This resistance acts as an open circuit to the low dc voltage corrosion current, but like a short to lightning or 120 Vac commercial current.

A3.4.4. Electrolytic Cell. An electrolytic cell (Kirk Cell) consists of multiple pairs of stainless-steel plates immersed in a potassium hydroxide electrolyte solution with an oil film floating on top to prevent evaporation. The cell acts like an electrochemical switch, blocking low dc voltages in the cathodic protection range, but instantaneously shunting ac or higher dc voltages to ground.

## Attachment 4

## BASIC BONDING REQUIREMENTS

**A4.1. Basic Requirements.** Three conditions or situations establish the requirement for a bond.

**Table A4.1. Conditions or situations.**

Condition 1	Condition 2	Condition 3
Common bonding of grounded systems – structures exceeding 60 ft (18 m)	Bonding of metal bodies (See definition for “structure.”) A. Structures 40 ft (12.2 m) and less (structures $\leq 40'$ B. Structures more than 40 ft (12.2 m) in height where bonding is required within 60 ft (18.3 m) from top of structure (structures $>40'$ and $\leq 60'$	Isolated (ungrounded) metallic bodies (such as metallic window frames)

**A4.2. See Figure A4.1, Condition 1.**

A4.2.1. Effective with the 2017 NFPA 780, for metal or steel-framed structures exceeding 60 feet (18 meters) in height, the interconnection of the lightning protection system grounding electrodes and other grounded media shall be in the form of a ground loop conductor. **(T-0)**. This interconnection shall include all building grounding electrode systems, including lightning protection, electrical service, communications service, and antenna systems grounding electrodes. For existing metal or steel-framed structures exceeding 60 feet (18 meters), metal bodies must be bonded as near as practical at their extremities (top and bottom) to structural steel members.

A4.2.2. For reinforced concrete structures where the reinforcement is interconnected and grounded, long, vertical metal bodies must be bonded to the lightning protection system down conductors (unless inherently bonded through construction) at their extremities (top and bottom). **(T-0)**.

**A4.3. See Figure A4.2, Condition 2.**

A4.3.1. Bonding of metal bodies not covered by Condition 1 (structure is  $\leq 60$  feet [18 meters]). Grounded metal bodies shall be bonded to the lightning protection system where located within a calculated bonding distance, D, as determined by the following BBF: **(T-0)**.

**Figure A4.1. . Basic bonding formula.**

$$D = \frac{hK_m}{6n}$$

A4.3.1.1. Where:  $D$  = calculated bonding distance,  $h$  = either the height of the building or the vertical distance from the nearest bonding connection from the grounded metal body to the lightning protection system and the point on the down conductor where the bonding connection is being considered.  $n$  = value related to the number of down conductors that are spaced at least 25 feet (7.6 meters) apart and located within a zone of 100 feet (30 meters) from the bond in question  $K_m = 1$  if the flashover is through air; 0.50 if through dense material such as concrete, brick, and wood.

A4.3.1.2. The value  $n$  shall be calculated as follows:  $n = 1$  where there is one down conductor in this zone;  $n = 1.5$  where there are two down conductors in this zone;  $n = 2.25$  where there are three or more down conductors in this zone. Application of this general formula is adjusted below, based on structure height. **For quick reference**, some calculated values for a single down conductor ( $n$ ) are shown below:

A4.3.1.3. Exterior. For items mounted on the exterior of a building on the same building face as a down conductor or another part of the LPS, where  $K_m = 1.0$  (air):

**Figure A4.2. Common Calculations.**

*At  $h=60$  inches,  $D=10$  inches*

*At  $h=42$  inches,  $D=7$  inches*

*At  $h=18$  feet,  $D=3$  feet*

*At  $h=20$  feet,  $D=3$  feet, 4 inches*

**Note:** that no masts or metal objects are allowed within 6 feet (1.8 meters) of the base of a building exterior wall, to provide a safe side flash distance and adequate work space at the base of a mast. See **Table A4.1**.

A4.3.1.4. Interior. For metal items on the interior of a building where  $K_m = 0.5$  (some solid medium previously described): *At  $h=42$  inches,  $D=3.5$  inches, but 6 inches is minimum distance; therefore  $D=6$  inches.* This applies to static bus bars installed on the interior of an exterior wall. No metal objects are allowed closer than 6 inches to the static bus bar (examples are metallic lockers, metallic tool boxes and similar items). At  $h=60$  inches,  $D=5$  inches, but, again, 6 inches is minimum distance; therefore,  $D=6$  inches.

#### **A4.4. Condition 2a.**

A4.4.1. For grounded metal bodies inside structures 40 feet (12.2 meters) and less in height. Grounded metal bodies shall be bonded to the lightning protection system where located within a calculated bonding distance (side flash distance),  $D$ , as determined by the following formula: **(T-0)**.

**Figure A4.3. Basic bonding formula.**

$$D = \frac{hK_m}{6n}$$

A4.4.1.1. Where:  $D$  = calculated bonding distance.  $h$  = **either** the height of the building **or** the vertical distance from the nearest bonding connection from the grounded metal body to the lightning protection system and the point on the down conductor where the bonding connection is being considered.  $n$  = value related to the number of down conductors that are spaced at least 25 feet (7.6 meters) apart and located within a zone of 100 feet (30 meters) from the bond in question  $K_m = 1$  if the flashover is through air;  $K_m = 0.50$  if through dense material such as concrete, brick, and wood.

A4.4.1.2. The value  $n$  shall be calculated as:  $n=1$  where only one down conductor is within 100 feet,  $n=1.5$  where two down conductors are within 100 feet, and  $n=2.25$  where three or more down conductors are within 100 feet.

A4.4.1.3. Down conductors not separated by at least 25 feet (7.6 meters) are considered one down conductor and  $n=1$ . An example of this calculation is shown in [Figure A4.1](#) The height of the building is 35 feet (10.7 meters). A is a metal pipe grounded at one end but close to down conductor. B is the only down conductor within 100 feet (30.5 meters) of the point in question, so  $n = 1$ . Since any flashover would occur through the wall,  $K_m = 0.5$ . The BBF is  $D = [h/6(1)](0.5) = (30 \text{ feet}/6)(0.5) = (5.0)(0.5) = 2.5 \text{ feet (0.76 meter)}$ . This means that if pipe A is 2.5 feet (0.76 meter) or closer to the down conductor at the point in question (30 feet [9.14 meters] in height), bond it through the wall to the down conductor. If installed within side flash distance, the design should relocate either the down conductor or offset the installation of the metallic object, pipe A, in this case.

#### **A4.5. See Figure A4.4, Condition 2b.**

A4.5.1. Note that for buildings between  $>40$  and  $\leq 60$  feet (12.2 and 18.3 meters) in height, Condition 2B would apply.  $D$  = calculated bonding distance.  $h$  = vertical distance between the bond under consideration and the nearest interconnection to the lightning protection system or ground.  $n$  = value related to the number of down conductors that are spaced at least 25 feet (7.6 meters) apart and located within a zone of 100 feet (30 meters) from the bond in question  $K_m = 1$  if the flashover is through air;  $K_m = 0.50$  if through dense material such as concrete, brick, and wood.

A4.5.1.1. The value  $n$  shall be calculated as:  $n=1$  where only one down conductor is within 100 feet (30 meters),  $n=1.5$  where two down conductors are within 100 feet, and  $n=2.25$  where three or more down conductors are within 100 feet (30 meters).

A4.5.1.2. Where bonding is required below a level 60 feet (18 meters) from the top of a structure,  $n$  shall be the total number of down conductors in the lightning protection system.

A4.5.1.3. See [Figure A4.4](#) shows bond fitting Condition 2b(1). The vertical height,  $h_1$ , is 75 feet (22.9 meters). In this case, the two down conductors are within 100 feet (30 meters)

of the bond at D1, and  $n$  equals 1.5. Again, the flashover would be through the wall, so  $K_m = 0.5$ . The BBF is  $D1 = ([75 / (6)(1.5)])0.5 = (75/9)(0.5) = 4.17$  feet (1.27 meters). If pipe A is 4.17 feet (1.27) meters or closer to the down conductor, bond it to the down conductor through the wall. If installed within side flash distance, the design should relocate either the down conductor or offset the installation of the metallic object if possible, pipe A, in this case.

#### A4.6. See Figure A4.5. Condition 2c.

A4.6.1. For grounded metal bodies where the bond in question is below the top 60 feet (18.3 meters) of a structure which is greater than 40 feet (12.2 meters) in height, the following definitions apply.  $h$  = the vertical distance between the bond being considered and the nearest other lightning protection system bond (or to ground level if no other bond is present).  $n$  = the total number of down conductors (spaced 7.6 m apart) in the lightning protection system.

A4.6.2. This type of bond is shown in [Figure A4.1](#) Pipe B comes close to a down conductor at a height below the top 60 feet (18.3 meters) of the structure.  $K_m$  would be 0.5 for a flash through the wall and  $n$  would be the total number of down conductors for the system assume four down conductors for the purpose of the following sample calculation. The BBF would be  $D2 = ([35/6(4)])0.5 = (35/24)(0.5) = 0.73$  foot (0.22 meter). The pipe B would have to be bonded through the wall to the down conductor at this location if it is 0.73 foot (0.22 meter) or closer to the conductor. For this example, a wall thickness of 8.8 inches would not require through-the-wall bonding. If installed within side flash distance, the design should relocate either the down conductor or offset the installation of the metallic object, pipe B, in this case. Note that for buildings between 40 and 60 feet (12.2 and 18.3 meters) in height, Condition 2b(1) would apply.

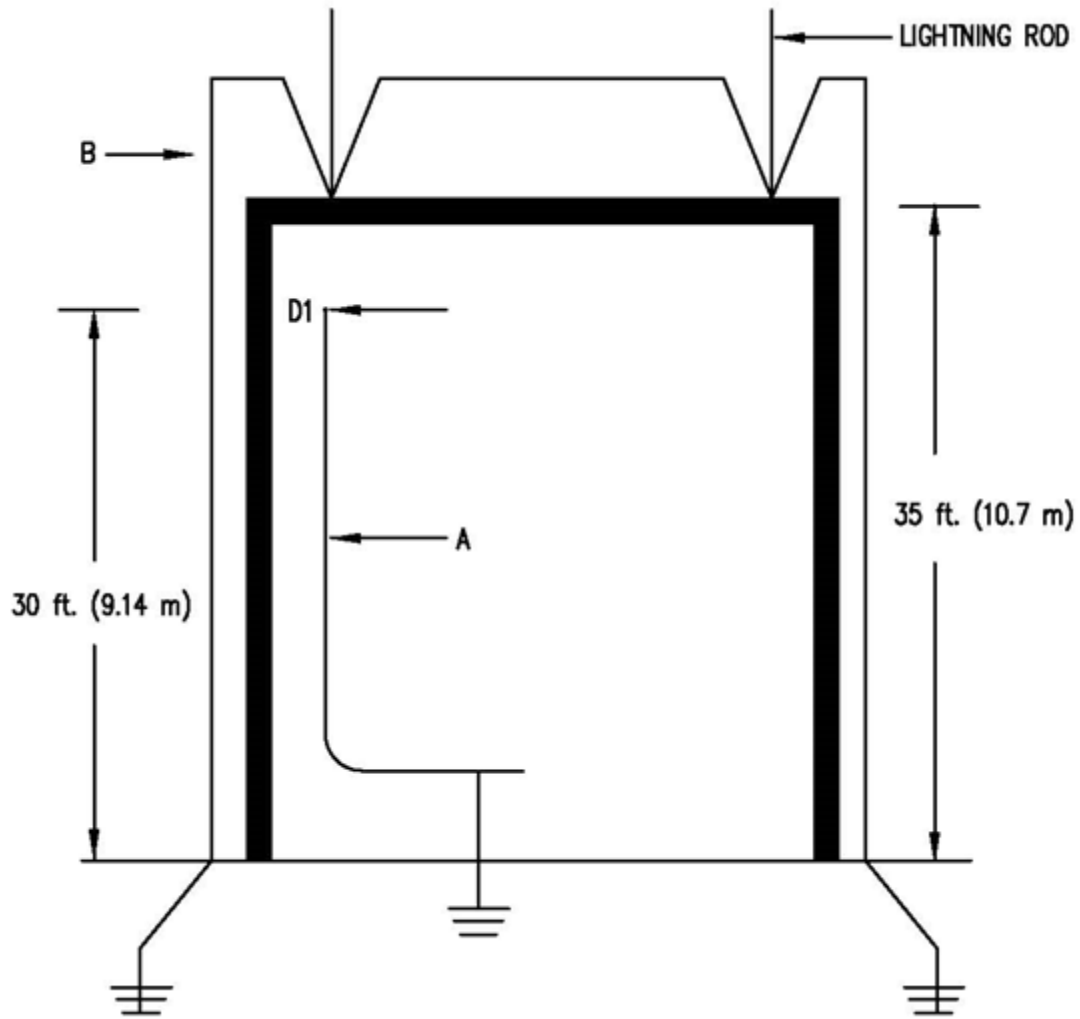
#### A4.7. Side Flash for Catenary Systems.

A4.7.1. For catenary systems, it is necessary to calculate the distance of the cable sag of the cross conductor to the nearest part of the facility or the position of the cross conductor that is nearest to any metal item mounted on top of the facility. The BBF must be used for this, but in no case shall the lowest part of the sag be less than 6 feet (1.8 meters) from the nearest part of the facility. **(T-0)**. See [Figure A5.1](#).

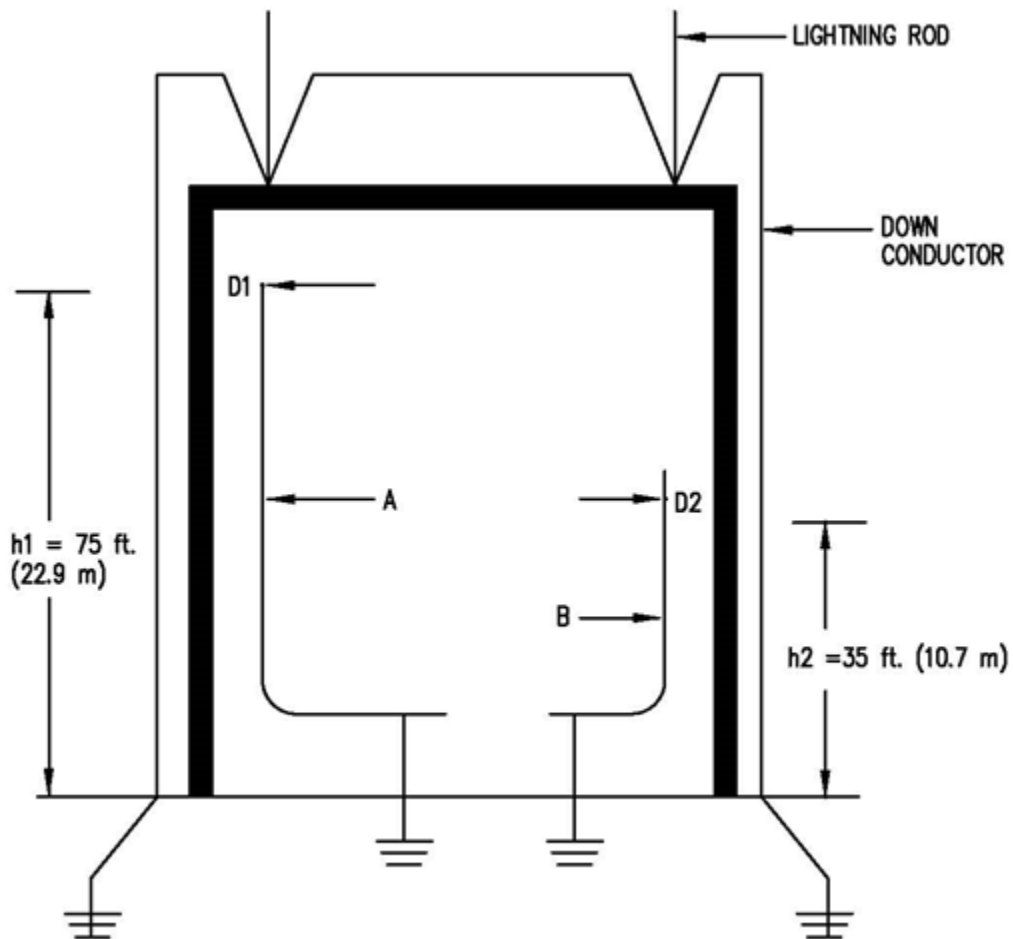
A4.7.1.1. For a metal mast or pole,  $h$  = the horizontal distance at the lowest point of sag to the top of the metal pole or mast.

A4.7.1.2. For a non-metal mast or pole,  $h$  = the horizontal distance at the lowest point of sag to the top of the non-metal mast or pole plus the vertical distance from the top of the mast or pole to the grounding point at its base.

Figure A4.4. Typical Bonding Conditions in Structures 40 Feet or Less in Height.

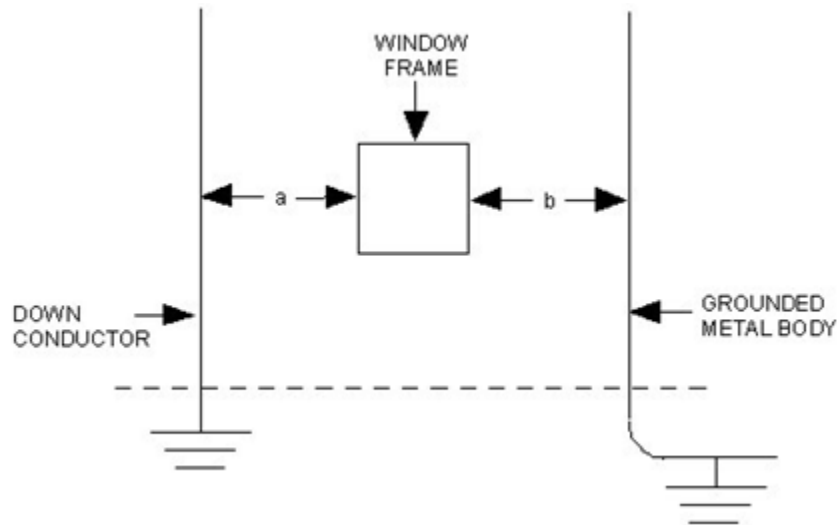


**Figure A4.5. Typical Bonding Conditions in Structures Greater Than 40 Feet in height. [D<sub>2</sub> cut off]**



**A4.8. Condition 3.** Bonding of ungrounded metal bodies positioned to effectively short part of the separation distance between a grounded metal body and a lightning conductor. In [Figure A4.6](#), a window is located between a grounded metal body and a lightning protection down conductor. First, calculate the bonding distance between the grounded body and down conductor by using the BBF according to the correct condition, from [paragraph A4.1](#) [1, 2A, or 2B]. This will provide a distance for D. If the distance  $a + b$  is less than or equal to D, then the down conductor must be bonded directly to the grounded metal body. Note the window itself does not have to be bonded. Continuity tests should be performed to determine if the object is grounded, and not ungrounded, as it may appear.

**Figure A4.6. Typical Bonding Conditions for Ungrounded Metal Bodies.**



**A4.9. Typical Air Force Situation. Figure A4.9** depicts a situation that typically occurs at Air Force bases. Boxes shown in Figures [A4.9](#) and [A4.11](#) represent various types of metallic electrical enclosures. These are required by the NEC to be grounded, and therefore constitute grounded metal bodies as defined by Condition 2 above. They would have to be bonded to the down conductor if separation from the down conductor is less than the distance determined by the BBF, Condition 2. Condition 3 would not apply between the door frame and the down conductor with objects 1 through 4 in between, because all are grounded. However, the BBF, Condition 2, must be applied between the down conductor and the doorframe. On explosives facilities where such objects do not need to be bonded, recommend they be marked or labeled "NBN" (No Bonding Needed) for future reference.

**Figure A4.7. Bonding Metallic Equipment to Down Conductor.**

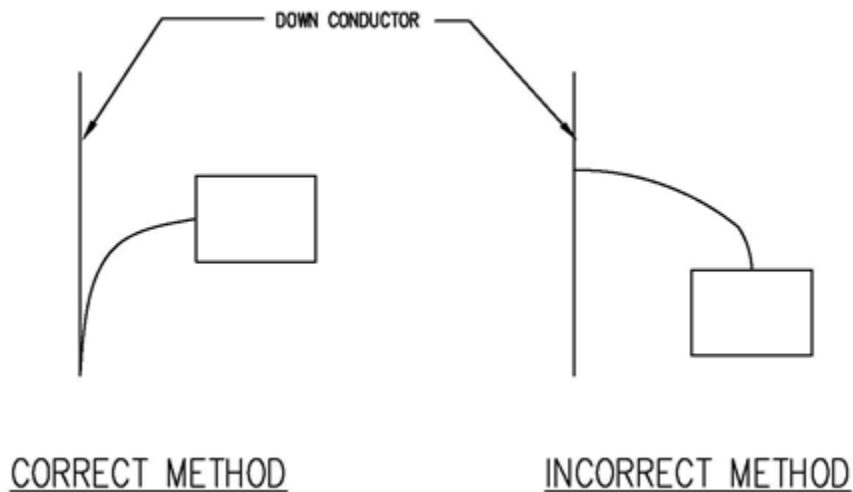


Figure A4.8. Bonding Down Conductor to Grounding Electrode.

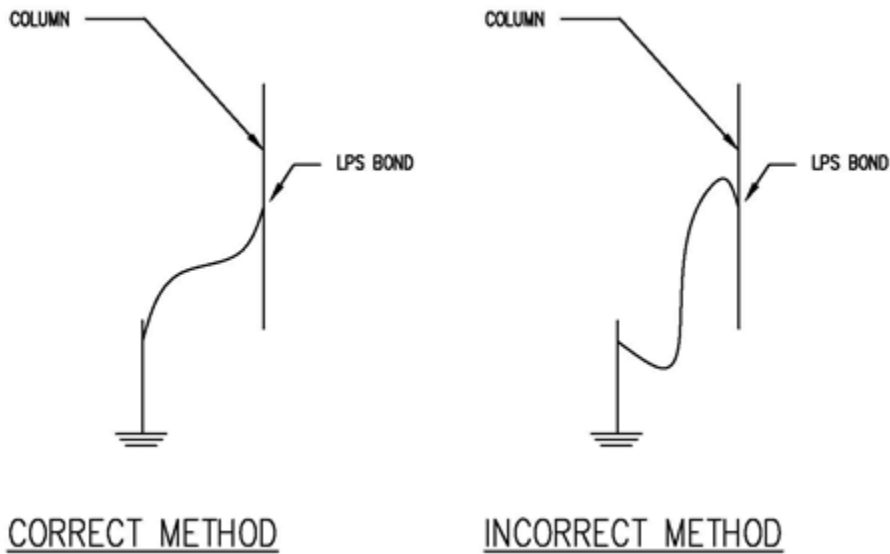
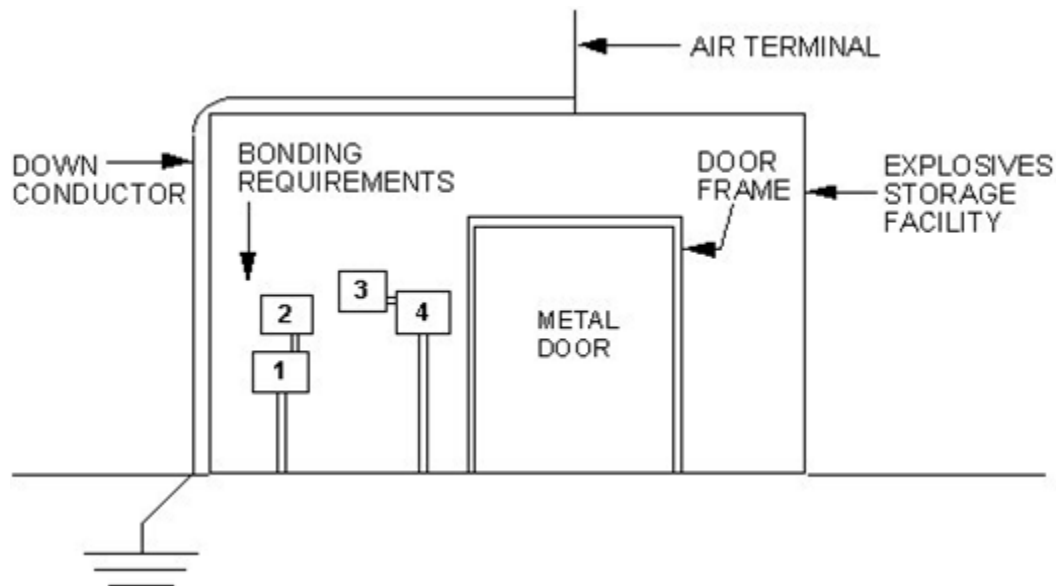


Figure A4.9. Bonding for Typical Air Force Structure.



**A4.10. Explosives Facility Bonding.** The following supplements the NFPA 780 bonding requirements for explosives facilities defined in [Chapter 3](#).

A4.10.1. See [Figure A4.10](#) provides approximate bonding distances as defined by NFPA 780. Note that this chart does not cover Conditions 1 and 2B from [paragraph A4.1](#) The terms  $h$ ,  $K_m$ , and  $n$  are. The terms  $h$ ,  $K_m$ , and  $n$  are defined in [paragraph A4.4](#) To demonstrate the use of the chart, it is used to solve the example in [paragraph A4.4](#).

**Figure A4.10. Sample Calculations of Bonding Distances.**

				<i>D</i>					
<i>h</i>		<i>K<sub>m</sub></i>	<i>n</i> = 1.0		<i>n</i> = 1.5		<i>n</i> = 2.25		
ft	m		ft	m	ft	m	ft	m	
10	3.05		1 ft 8 in.	0.50	1 ft 13/8 in.	0.33	9 in.	0.22	
		0.5	10 in.	0.25	63/4 in.	0.17	4 1/2 in.	0.11	
20	6.10		3 ft 4 in.	1.01	2 ft 23/4 in.	0.67	1 ft 6 in.	0.45	
		0.5	1 ft 8 in.	0.50	1 ft 13/8 in.	0.33	9 in.	0.22	
30	9.15		5 ft 0 in.	1.52	3 ft 4 in.	1.01	2 ft 23/4 in.	0.67	
		0.5	2 ft 6 in.	0.76	1 ft 8 in.	0.50	1 ft 13/8 in.	0.33	
40	12.2	1	6 ft 8 in.	2.03	4 ft 6 in.	1.37	3 ft	0.91	
		0.5	3 ft 4 in.	1.01	2 ft 3 in.	0.68	1 ft 6 in.	0.45	

1. Find the height (*h*) (9.15 m) in the column labeled *h*.

2. Then select the row adjacent to the 9.15 m where *K<sub>m</sub>* is 0.5, since any flashover would occur through the wall.

3. Since there is only one down conductor, *n* equals 1. Find the intersection of the row selected in step 2 and the column labeled 1.0. The value in the cell is 0.76 m. Therefore, *D* is 0.76 m or 2 ft 6 in.

Also notice that the greatest bonding distance for objects not covered by 2b(2) inside a facility less than 12.2 m in height is 1.01 m (3 ft 4 in).

*This table derived from NFPA 780*

A4.10.2. Steel magazine doors inherently in physical contact with the metallic door frame do not need a separate bond if the resistance between the door and frame measures 1 ohm or less. Install a bonding strap if this resistance between the door and frame measures greater than 1 ohm. The frame must be inherently grounded through the rebar or bonded to a down conductor.

A4.10.3. Objects such as metal desks, metal lockers, large metal trash cans, and ground-level floor grates do not need to be bonded unless they are located within side flash distance of a component of the lightning protection system or a static bus bar.

A4.10.4. Fence posts and railroad tracks within 6 feet (1.83 meters) of any component of a structure's lightning protection system must be bonded either to the structure's grounding system or to a ground rod which is bonded to the structure's grounding system. In addition, fence posts at gates where either personnel or explosives equipment may pass must be grounded. These are test points.

A4.10.5. Blast valves must be inherently grounded through the rebar system or with a separate bonding strap.

A4.10.6. Metal bodies located within a steel-framed structure that are inherently bonded to the structure through construction must be tested when the facility is new and the measurements recorded and kept with the other required measurements and observations. They do not need to be tested again unless there is reason to believe the bond has changed, e.g., corrosion or structural repair.

**A4.11. Protective Aircraft Shelters (PAS).** In PASs with interior steel arches, all grounded metal bodies within 1 foot (0.305 meter) of the steel arch must be bonded to the arch. In PASs without a steel arch, all grounded metal masses within 1 foot (0.305 meter) of a wall must be bonded to the nearest metallic electrical conduit if not already connected. Only those grounded metal bodies not inherently bonded (through metallic conduit or equipment grounding conductor) must be tested for continuity to the ground or conduit system. All metal doors must be grounded. Door hinges and door tracks are acceptable as a bonding strap if the doorframe or door track is grounded and there is less than 1 ohm between the door and ground. Additional requirements for PASs with WS3 vaults are as follows:

A4.11.1. Continuity between the steel arch and grounding system may be measured by validating with an ohmmeter the continuity between the steel arch and any metallic electrical conduit. Two test points between different conduits and the arch are sufficient if the test points are spaced on opposite walls and the conduit long. This is to ensure electrical continuity through the structural shell. If a maximum of 1 ohm is not achieved, a bonding strap must be installed.

A4.11.2. When testing continuity between the WS3 vault and steel arch, an acceptable test location is the vault lip or flange flush with the shelter floor. The vault does not have to be raised. Where there is no steel arch, test from a metallic electrical conduit on the PAS wall to the vault lip.

A4.11.3. **(Added-USAFE-AFAFRICA) WS3 Floor Plates:** Continuity between the WS3 Floor Plate and vault lip shall be less than 1-ohm.

A4.11.4. **(Added-USAFE-AFAFRICA) 4-Part PAS Doors:** Continuity between each door section and PAS arch shall be less than 1-ohm.

## Attachment 5

### LIGHTNING PROTECTION SYSTEMS

**A5.1. Minimum Requirements.** Engineers assigned specific responsibilities for lightning protection must review the lightning protection system on each facility at least annually or after repair actions have been completed. **(T-0).**

A5.1.1. Air terminals must extend at least 10 inches (0.25 meter) above the object to be protected. **(T-0).** Consider the use of blunt-tipped air terminals for new system installations on Air Force installations. **Note:** When replacing air terminals with terminals of a different length, required spacing around the perimeter must be reconfirmed and the zone of protection verified. **Figure A5.1** 1:1 zone of protection in NFPA 780 should extend from the tip of the air terminal instead of the eave.

A5.1.2. Each air terminal mounted separately from the facility (non-integral system) (except as exempted in NFPA 780) must have at least two paths to ground. **(T-0).** For a catenary system consisting of non-metallic poles or masts, the second path may be one of the cross conductors to the next pole or mast. For a metallic mast, the base must be bonded to two separate grounding electrodes, as far apart as possible (opposite sides of the mast is the goal). Note that for earth-covered igloos, these paths may be covered with soil.

A5.1.3. Each building with an integral protection system must have a minimum of two down conductors, one each at opposite corners (one each on all corners is preferred). **(T-0).** This provides two paths to ground. Because of the potential for galvanic corrosion, use only aluminum lightning system conductors on metal roofs. **(T-2).**

A5.1.4. Down conductor design and installation must present the least possible impedance to ground. **(T-0).**

A5.1.5. Down conductors must not have sharp bends or loops. All bends must have a radius of bend not less than 8 inches (0.203 millimeters) and must measure not less than 90 degrees from the inside of the bend. **(T-0).** The 8-inch (203-millimeter) radius does not apply to "T" or "Y" splices. These splices, however, can be used only for the purpose intended.

A5.1.6. If the structure has metallic columns, these columns may serve as down conductors as long as columns do not average more than a 60-foot (18.3-meter) separation distance. Inherent bonding via continuity measurements must be shown on as-built drawings for new facilities. **(T-0).** If not shown at the time of construction, access points for testing must be provided and validated prior to project acceptance. **(T-0).**

A5.1.7. Structures must have at least two down conductors, separated as widely as practicable. **(T-0).** Diagonally opposite corner locations achieve this easily. Structures exceeding 250 feet (76 meters) in perimeter shall have a down conductor for every 100 feet (30.5 meters) of perimeter or fraction thereof. **(T-0).**

A5.1.8. Any down conductors subject to mechanical damage or displacement must be protected with a protective molding or covering for a minimum of 6 feet (1.83 meters) above grade. **(T-0).** If a down conductor runs through a ferrous metal tube or pipe (usually for mechanical protection), the conductor must be bonded to both ends of the tube or pipe (at point of entry and exit). **(T-0).**

A5.1.9. Do not paint down conductor connectors unless they are high-compression, exothermic, or welded type. Conductors on roofs must be bare.

A5.1.10. Each down conductor must be connected, at its base, to a grounding electrode or to a ground loop conductor, keeping in mind the bending restrictions of the down conductor. **(T-0)**.

A5.1.11. Grounding electrodes must be at least 10 ft. (3.05 m) long and made of not less than 0.75-inch (19.05-millimeter) diameter pipe or equivalent solid rod made of copper or copper-clad steel. **(T-0)**. Stainless-steel grounding electrodes must not be used. Grounding electrodes must be at least 3 feet (0.91 meters) from the building walls or footings and must penetrate at least 10 feet (3.05 meters) into soil. **(T-0)**. Grounding electrodes with tops at least 1 foot (0.31 meter) below grade are recommended for mechanical protection. If conductors are not exothermically welded to the grounding electrode, test wells are required for new construction. **(T-0)**.

A5.1.12. The location of new down conductors on the exterior of a structure should take into consideration interior wall-mounted objects and be adjusted to avoid them. If avoidance is not optional or for existing facilities, interior metal parts of a facility close to a down conductor will need to be bonded to that down conductor if within the calculated side flash distance. **(T-0)**.

A5.1.13. Bonding materials must be compatible with the metallic mass and down conductor. **(T-0)**.

A5.1.14. On new facilities, down conductors entering soil with less than 10,000 ohm-cm resistivity must be protected against corrosion by a protective covering beginning 6 feet (1.83 meters) above finished grade. **(T-0)**.

A5.1.15. Adhesive fasteners for down conductors and cross conductors of an integral system are not allowed on Air Force facilities due to the short adherence life of the adhesive.

A5.1.16. A ground loop conductor (ground ring) encircling the building must be at least 1.5 feet (0.46 meters) deep, be at least 20 feet (6.1 meters) long and be a main-size conductor, sized from NFPA 780, Table 4.1.1.1.1 or 4.1.1.1.2). **(T-0)**.

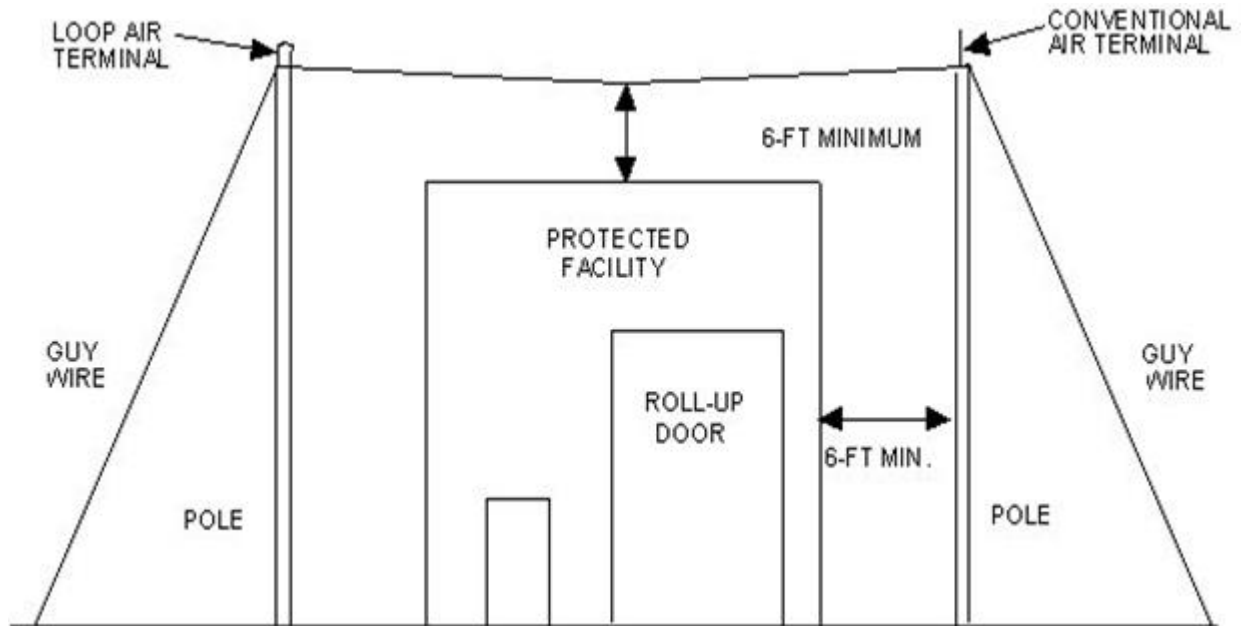
## **A5.2. Mast and Overhead Wire Systems.**

A5.2.1. A mast-type lightning protection system uses masts located remote from the facility. The mast must be high enough to enclose the facility in the zone of protection defined by NFPA 780. **(T-0)**. Separate each mast from any part of the facility by at least the bonding distance specified in paragraph 4.6.5 of NFPA 780, but not less than 6 feet (1.83 meters). **(T-0)**. Refer to [Figure A5.1](#).

A5.2.2. If a single mast will not protect a facility, install multiple masts or an overhead wire system. An overhead wire or catenary system consists of grounded, elevated, horizontal metallic wires stretched between masts surrounding the facility. Each wire must be a continuous run of at least AWG No. 6 copper or equivalent. **(T-0)**. Suspend each wire above the protected facility and connect them to grounding electrodes at each mast or pole. Interconnect all grounding electrodes with a ground loop conductor. NFPA 780, paragraphs 4.16.2.5 and 4.16.2.6, specify the minimum separation between the overhead wire and the protected facility, which must be at least equal to the bonding distance or side flash distance.

(T-0). A minimum of 6 feet (1.83 meters) is recommended. Supporting masts must be separated by the side flash distance, but no less than 6 feet (1.83 meters). (T-0).

Figure A5.1. Air Terminals on Masts (Typical).



A5.2.3. An air terminal extending above the top of the pole must be securely mounted to the top of the wooden mast and connected to the grounding system. (T-0). An overhead ground wire or a down conductor, extending above or across the top of the pole, may serve as the air terminal if this wire or conductor is the topmost item on the mast. Each nonmetallic mast must provide two paths to ground. A lone nonmetallic mast must have two down conductors. Metallic masts do not require air terminals and down conductors. Metallic masts must have two connections to the grounding system or to two grounding electrodes. (T-0).

## Attachment 6

### MAINTENANCE SELF-CHECK FOR EXPLOSIVES FACILITIES

**A6.1. Maintenance Self-check for explosive facilities.** Questions for Maintenance self-check for explosive facilities include:

A6.1.1. Has each facility been inspected to determine the type of protection system installed? Is the system mounted on the facility (integral) or separately mounted (mast or overhead system)?

A6.1.2. Are maintenance personnel familiar with lightning protection systems? See [Chapter 4](#) for personnel qualifications and training requirements.

A6.1.3. Are all maintenance personnel who are qualified to perform tests or inspections familiar with this AFMAN? Are all contractors or architect or engineers for large contracts within the explosives area familiar with this AFMAN?

A6.1.4. Do all contracts and projects (even if non-LPS) on facilities with LPS require certification and recertification of the LPS and as-builts (if construction changes are made), prior to acceptance and payment of the last 25 percent of the contract to the contractor (this includes SABER contracts)? This will ensure compliance with this AFMAN for new facilities and will ensure that no deficiencies have been introduced onto the existing LPS of existing facilities by a non-LPS contract.

A6.1.5. Are static grounding systems installed as separate subsystems? Are they connected only to a lightning protection system down conductor (when within side flash distance) or to a ground loop conductor? Are contact points free of corrosion, paint, grease, oil, or other agents that prevent good bonding? Are static bus bars bonded to the single point facility ground at each end? **Note:** If interior static bus bars cross an exterior down conductor within calculated side flash distance, relocate the down conductor or the static bus bar to avoid this crossing. See [paragraph 13.2](#) of this AFMAN.

A6.1.6. Are both the user and maintenance personnel aware of all facilities that have been identified as housing, or being used to conduct, hazardous operations? Are personnel familiar with any special test and inspection requirements?

A6.1.7. Are tests and inspections accomplished at the frequencies shown in [Table A2.1](#) of this AFMAN?

A6.1.8. Are tests conducted with test instruments designed for the purpose used?

A6.1.9. Are personnel conducting tests familiar with the location and designation of test points and the relationship between various components of the system prior to testing?

A6.1.10. Are visual inspections being performed in accordance with [Table A2.1](#) of this AFMAN?

A6.1.11. Are repair actions performed when reported?

A6.1.12. After repair actions have been completed, are electrical tests accomplished and documented, to ensure system integrity and records accuracy?

## Attachment 7

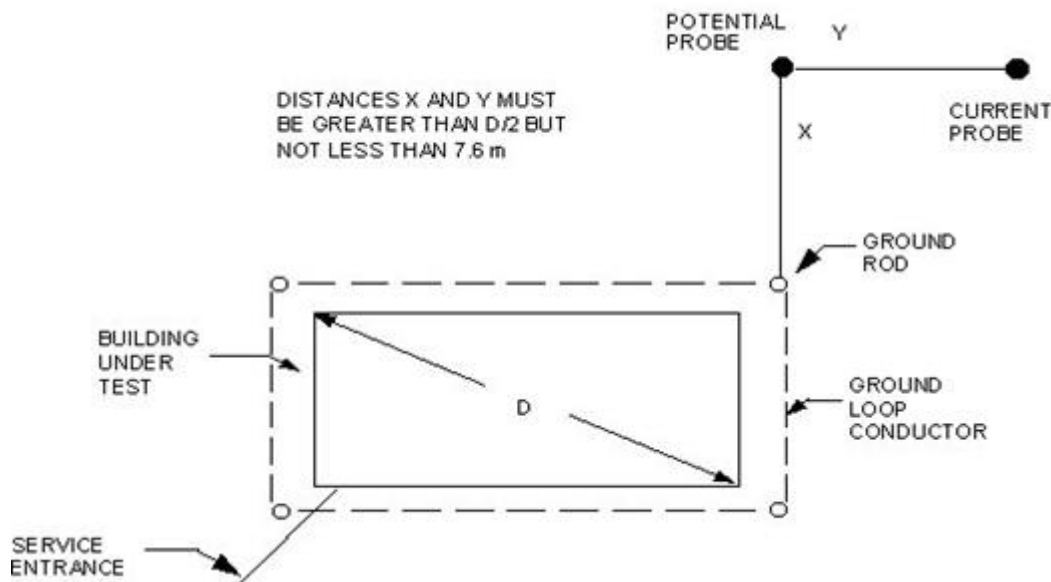
## TESTING REQUIREMENTS

**A7.1. Grounding System Resistance Test.** Use the following procedures or the procedures recommended by the test instrument manufacturer (T-0):

A7.1.1. Use **Figure A7.1** illustrates auxiliary probe locations for fall-of-potential ground resistance tests.

A7.1.2. Where possible, conduct this test at the corner of the building opposite the electrical service entrance. Exercise caution: underground metallic piping may influence readings. Position probes as far as possible from the grounding system under test. You may temporarily disconnect electrical service from other ground connections; however, make sure you reconnect the ground or a shock hazard will result. Connect the appropriate lead of a fall-of-potential meter to the grounding electrode (ground rod) at the test site. Place the potential reference probe at a distance greater than one-half the diagonal of the building under test, but not less than 25 feet (7.6 meters). Place the current reference probe 90 degrees from the potential reference probe (in a direction away from the facility under test) and the grounding electrode under test, and at a distance greater than one-half of the building diagonal but not less than 25 feet (7.6 meters) from the potential reference probe. Note that the distances between probes are equal. For buildings without a ground loop conductor, perform this test at each grounding electrode. Resistance at each grounding electrode should be less than 25 ohms (10 ohms for communications facilities). Periodic tests should be made at approximately the same time each year to minimize confusion resulting from seasonal changes.

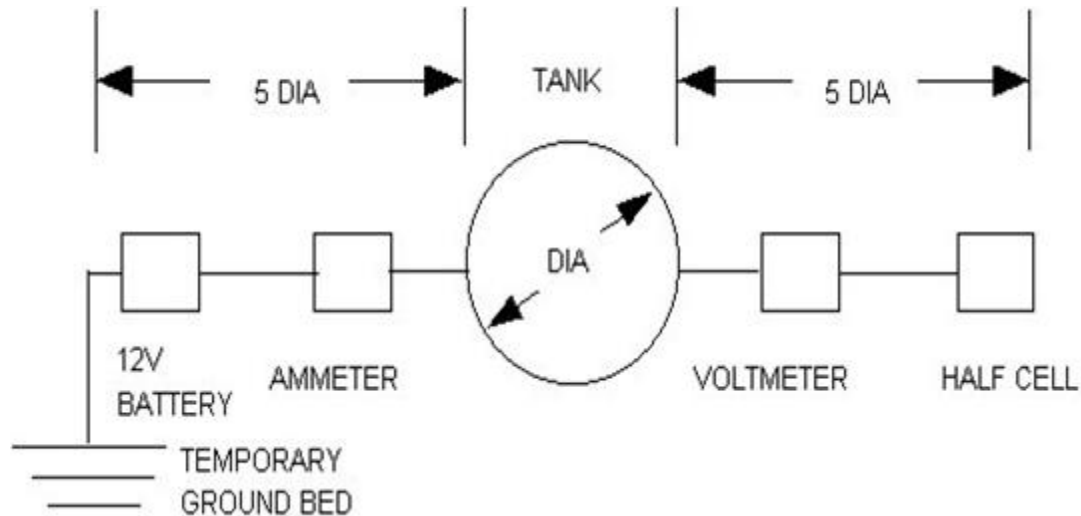
**Figure A7.1. Auxiliary Probe Locations for Fall-of-Potential Ground Resistance Test.**



**A7.2. Resistance Test for Above-Ground Petroleum (POL) Tanks. Note:** Before any testing is performed for POL systems and tanks, the tester shall be familiar with the containment systems, their locations, and their configurations to avoid puncture and compromise of the containment

system. If records of these containment system layouts are not contained in record drawings, they shall be located and defined and included in record drawings. The method described in [paragraph A7.1](#) is appropriate for medium to small grounding systems. [Figure A7.2](#) illustrates a method to measure resistance to earth of larger, more complex systems such as a large POL tank or a substation. In areas where the soil resistivity is relatively high, a higher voltage supply may be necessary. Local cathodic protection technicians can usually furnish the material for the test. Make sure the tank is isolated from the utility systems by dielectric flanges. Also be sure the cathodic protection systems are disconnected.

**Figure A7.2. Measuring Resistance to Earth of Large POL Tank.**



A7.2.1. Install a temporary ground bed of three or four 5-foot (1.52-meter) grounding electrodes at a distance equal to five tank diameters. Place a copper-copper sulfate half-cell on the opposite side of the tank. Place it at a distance equal to five tank diameters and along an imaginary straight line through the center of the tank. Make sure it has good contact with earth.

A7.2.2. Between the temporary ground bed and tank, install a 12-volt common vehicle battery and a dc ammeter (multimeter with 1-amp scale may be used). Install a high-impedance (10 megaohm or greater) dc voltmeter with a 1-volt scale between the half cell and tank.

A7.2.3. With the battery disconnected, record the voltage reading at the voltmeter.

A7.2.4. Connect the battery and record the current at the ammeter and voltage at the voltmeter. Read voltage immediately after connecting the battery. Current output must be sufficient to effect a minimum 0.05 volt potential shift in the half cell reading.

A7.2.5. Calculate resistance of the tank to earth in ohms by dividing the potential change in volts, DV, by the current in amps, or  $R = DV/I$ . For large tanks, typical values would be 0.040 amps of current and a voltage change of 0.2 volt.

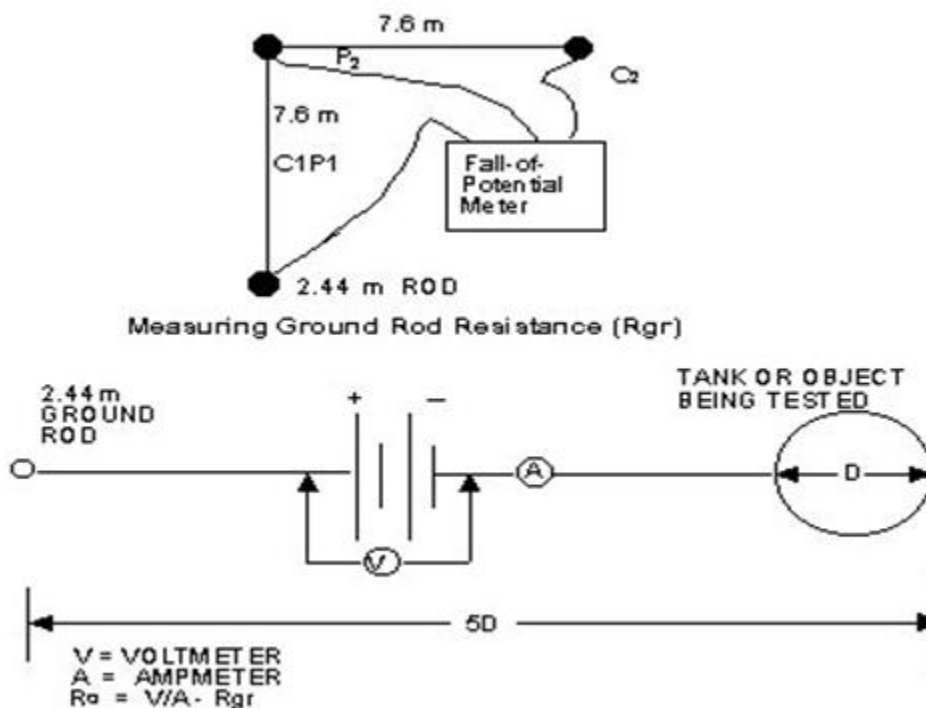
**A7.3. Resistance Test for Large Objects.** This procedure is an alternative to [paragraph A7.2](#) for measuring the resistance to earth of large metallic objects or grids. Be sure to isolate the tank (or object) from the utility system and turn off any cathodic protection system.

A7.3.1. Install an 8-foot (2.44-meter) ground rod 5 diameters from the tank or object being tested. Measure the resistance of this rod to ground using a fall-of-potential meter. This is the value of  $R_{gr}$ .

A7.3.2. Next, hook up the circuit as shown in **Figure A7.3**. The resistance of the tank (or object) to earth is determined by  $R_o = V/A - R_{gr}$ , where  $V$  is the reading from the voltmeter and  $A$  is the reading from the ammeter. The ammeter typically reads between 0.1 amp and 2 amps with a 12-volt source.

A7.3.3. If soil resistivity is very high, increase the voltage until enough amps flow to be measurable.

**Figure A7.3. Alternate Method of Measuring Resistance to Earth of Large Object.**



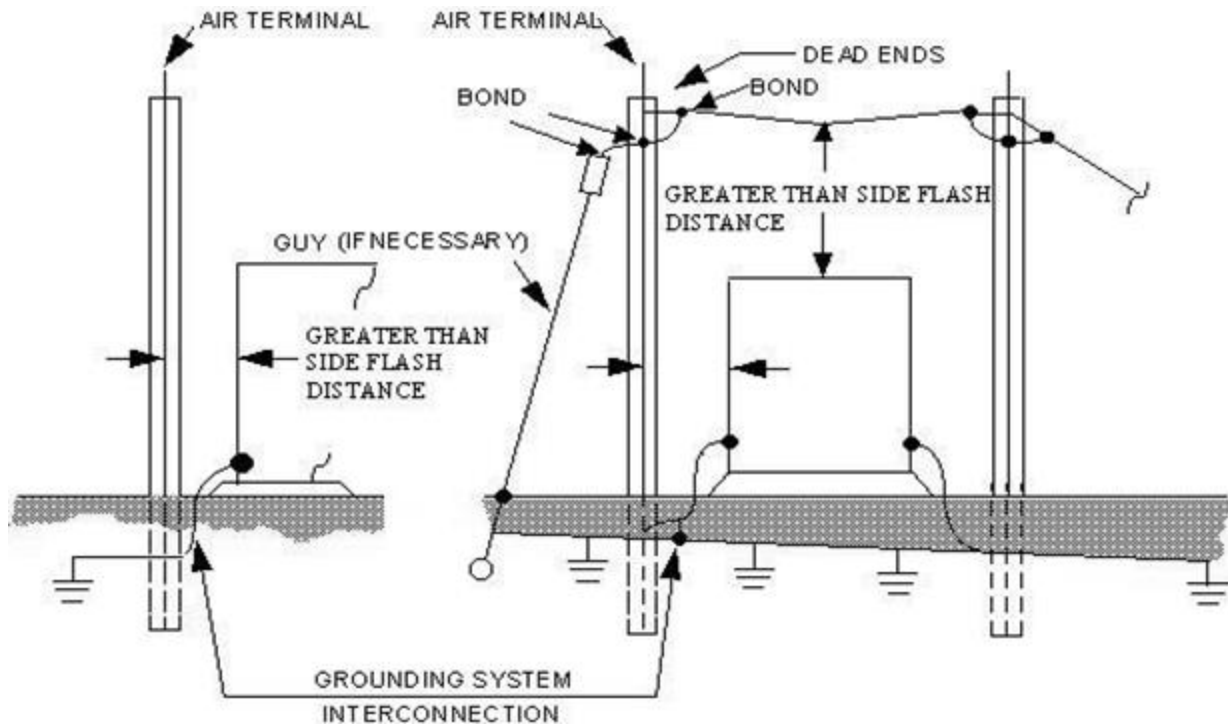
#### A7.4. Continuity Test/Check for Separately Mounted Lightning Protection System (Mast and Overhead Shield Wire).

A7.4.1. To test the continuity of a mast (**Figure A7.4(a)**), connect one lead of an ohmmeter to the top of the pole. Connect the other lead to the point where the conductor connects to the ground system at ground level. If the resistance is greater than 1 ohm, check for deficiencies and repair. For mast systems where the masts are metallic, seamless construction of a height to provide adequate protection, the continuity test can be conducted from the base of the mast. Field work which invalidates the manufacturer's warranty is not allowed. Initial continuity test of the slip-fit joint at the time of installation shall be recorded in test records. Also record whether or not the slip-fit joint is inherently bonded.

A7.4.2. For an overhead wire, or catenary, system (**Figure A7.4(b)**), visually inspect overhead shield wires with binoculars. If the system contains mechanical connectors, a continuity test must be conducted from the overhead shield wire to the point where the conductor connects to

the lightning protection ground system. This also applies to guy wires when guy wires are used as a path to ground (used as a down conductor). If the resistance is greater than 1 ohm, check for deficiencies and repair. For systems which use only exothermic welds or high compression crimps, a visual inspection may be used to verify overhead wire and down conductor continuity. The visual inspection may be conducted from ground level using binoculars.

**Figure A7.4. Mast System (a) and Overhead Wire or Catenary System (b).**



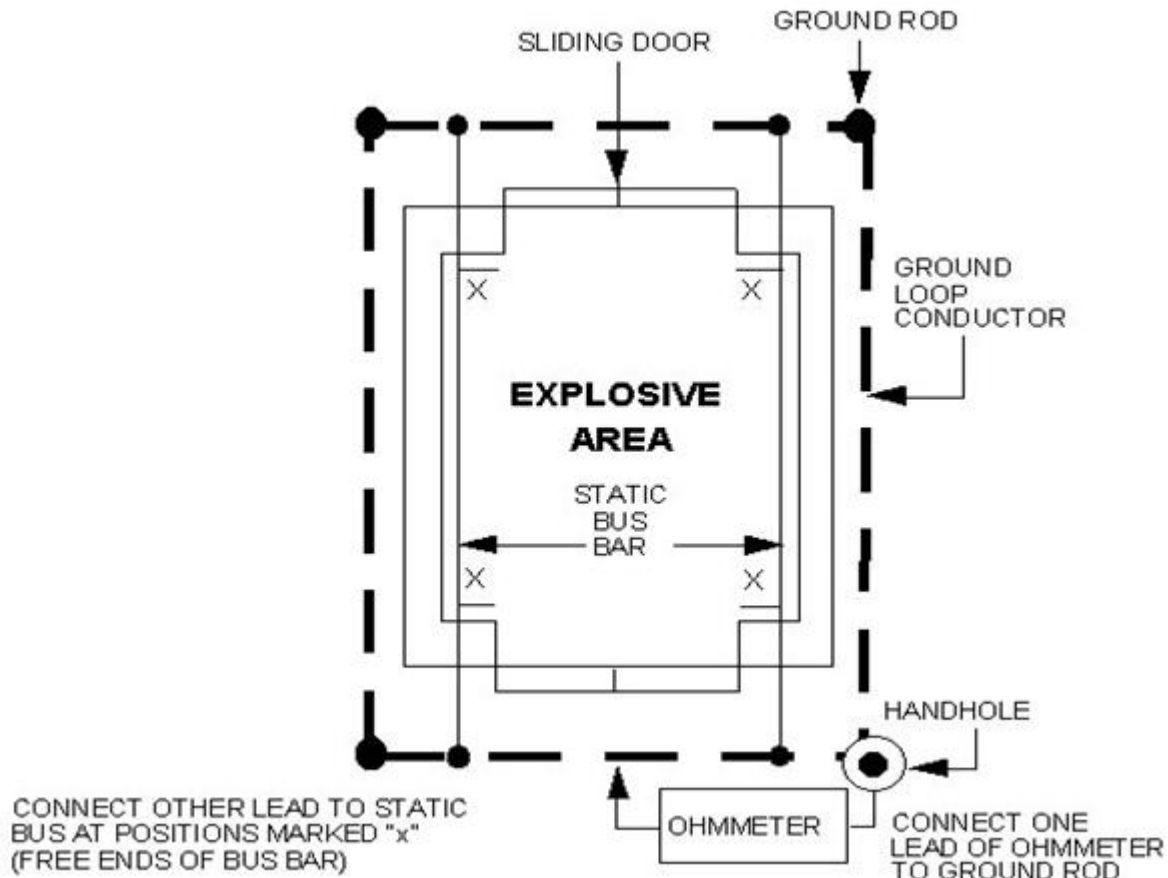
**A7.5. Continuity Test/Check for Integrally Mounted Lightning Protection Systems.** Perform this test by firmly attaching one lead of an ohmmeter to a corner ground rod. Next, connect the other lead consecutively to each of the air terminals located at the corners of the building and the air terminal (or metallic body) with the highest elevation. Repeat the test from the ground rod located at the opposite corner of the building. For explosive facilities, test the continuity to each air terminal. If the continuity of the system is good, the resistance value at any given test point should be about the same. Investigate any reading over 3 ohms. **Note:** Tests can also be performed from ground rod to nearest corner air terminal and from that corner terminal to the other corner terminals.

**A7.6. Testing for Static Bus Bars.** Test static bus bars by connecting one lead of a digital ohmmeter to a ground rod of the facility grounding system. Connect the other lead (in turn) to all the free ends of the bus bar. Bolted connections between bus bar sections are not considered free ends. [Figure A7.5](#) shows how a typical static bus bar test is performed. Investigate any reading more than 3 ohms and correct it. Perform a visual inspection to ensure materials and connections are in good condition.

**A7.7. Conductive Floor Tests.** Before using test instruments, be sure the room is free of exposed explosives. To determine floor resistance, measure between two electrodes placed 3 feet (0.91 meter) apart anywhere on the floor. Each electrode shall weigh 5 pounds (2.27 kilograms) and

have a dry, flat circular surface area 2.5 inches (63.5 millimeters) in diameter. The resistance between an electrode placed anywhere on the floor and a ground connection shall not be less than 25,000 ohms. For more information see IEEE Std 142 and NFPA 99.

**Figure A7.5. Testing Static Bus Bars in Typical Explosives Area.**



**Figure A7.6. Sample Visual Inspection Form.**

<b>XX Civil Engineer Squadron Visual Inspection of Lightning Protection and Grounding System. (For visual inspections only, fill out the first half of the form. There will be no resistance readings unless follow-up test is required from a previous poor reading or if repair is necessary at a test point. Document the retest and repairs in "Discrepancies or Test Notes" below.)</b>				
Building _____				
<b>Date of Inspection:</b>	day/month/year	<b>Inspection Performed By:</b>		<b>Inspector's Initials</b>
Yes	No	Visual Inspection of Lightning Protection System		
		<b>Is the lightning protection system in good repair?</b> IAW AFMAN 32-1065, Section B, para. 9.1, and NFPA 780, Annex D, para. D.1.2 (1)		
		<b>Are there loose connections that might cause high-resistance joints?</b> IAW AFMAN 32-1065, Section B, para. 9.2, and NFPA 780, Annex D, para. D.1.2 (2)		

	<b>Has corrosion or vibration weakened any part of the lightning protection system?</b> IAW AFMAN 32-1065, Section B, para. 9.3, and NFPA 780, Annex D, para. D.1.2 (3)										
	<b>Are down conductors, roof conductors, and ground terminals intact?</b> IAW AFMAN 32-1065, Section B, para. 9.4, and NFPA 780, Annex D, para. D.1.2 (4)										
	<b>Are braided bonding wires excessively frayed?</b> (cross-sectional area reduced by half) IAW AFMAN 32-1065, Section B, para. 9.5										
	<b>Are ground wires on the lightning protection masts damaged by lawn mowers or other equipment?</b> IAW AFMAN 32-1065, Section B, para. 9.6										
	<b>Are conductors and system components securely fastened to mounting surfaces?</b> IAW AFMAN 32-1065, Section B, para. 9.7, and NFPA 780, Annex D, para. D.1.2 (5)										
	<b>Have additions or alterations to the protected structure required additional protection?</b> IAW AFMAN 32-1065, Section B, para. 9.8, and NFPA 780, Annex D, para. D.1.2 (6)										
	<b>Do surge suppression (over voltage) devices appear damaged?</b> IAW AFMAN 32-1065, Section B, para. 9.9, and NFPA 780, Annex D, para. D.1.2 (7)										
	<b>Does the lightning protection system comply with applicable sections of NFPA 780 and AFMAN 32-1065?</b> IAW AFMAN 32-1065, Section B, para. 9.10, and NFPA 780, Annex D, para. D.1.2 (8)										
Is there a counterpoise grounding system								Test well ground resistance reading			Ω
Soil condition on date of Inspection			Ambient Temp °F			Test reel resistance reading			Ω		
Continuity test from test well to static ground system / minus the test reel resistance											
Test Point	Resistance Reading	Test Point	Resistance Reading	Test Point	Resistance Reading	Test Point	Resistance Reading	Test Point	Resistance Reading	Test Point	Resistance Reading
1	Ω	15	Ω	29	Ω	43	Ω	57	Ω	71	Ω
2	Ω	16	Ω	30	Ω	44	Ω	58	Ω	72	Ω
3	Ω	17	Ω	31	Ω	45	Ω	59	Ω	73	Ω
4	Ω	18	Ω	32	Ω	46	Ω	60	Ω	74	Ω
5	Ω	19	Ω	33	Ω	47	Ω	61	Ω	75	Ω
6	Ω	20	Ω	34	Ω	48	Ω	62	Ω	76	Ω
7	Ω	21	Ω	35	Ω	49	Ω	63	Ω	77	Ω
8	Ω	22	Ω	36	Ω	50	Ω	64	Ω	78	Ω
9	Ω	23	Ω	37	Ω	51	Ω	65	Ω	79	Ω
10	Ω	24	Ω	38	Ω	52	Ω	66	Ω	80	Ω
11	Ω	25	Ω	39	Ω	53	Ω	67	Ω	□ □ □ □	
12	Ω	26	Ω	40	Ω	54	Ω	68	Ω		
13	Ω	27	Ω	41	Ω	55	Ω	69	Ω		
14	Ω	28	Ω	42	Ω	56	Ω	70	Ω		
Continuity test from test well to lightning protection system / minus the test reel resistance											
Test Point	Resistance Reading	Test Point	Resistance Reading	Test Point	Resistance Reading	Discrepancies or System Notes:					
1	Ω	4	Ω	7	Ω						
2	Ω	5	Ω	8	Ω						
3	Ω	6	Ω		Ω						
Date of next visual inspection:								Date of next 24-month test:			
Technician / Inspector Signature:											
Facility Point of Contact & Phone Number:											
Printed Name / Signature / Date:											
Signature of inspection form certifies review and receipt of duplicate inspection form											

**Figure A7.7. Sample 24-Month Resistance/Continuity Test/Visual Inspection of LPS and Grounding System.**

<b>XX Civil Engineer Squadron 24-Month Resistance/Continuity Test and Visual Inspection of Lightning Protection and Grounding System</b>											
<b>Building _____</b>											
<b>Date of Tests/Inspection:</b>		<b>day/month/year</b>		<b>Tests/Inspection Performed By:</b>				<b>Technician/Inspector Initials</b>			
Yes	No	Visual Inspection of Lightning Protection System									
		<b>Is the lightning protection system in good repair?</b> IAW AFMAN 32-1065, Section B, para. 9.1, and NFPA 780, Annex D, para. D.1.2 (1)									
		<b>Are there loose connections that might cause high-resistance joints?</b> IAW AFMAN 32-1065, Section B, para. 9.2, and NFPA 780, Annex D, para. D.1.2 (2)									
		<b>Has corrosion or vibration weakened any part of the lightning protection system?</b> IAW AFMAN 32-1065, Section B, para. 9.3, and NFPA 780, Annex D, para. D.1.2 (3)									
		<b>Are down conductors, roof conductors, and ground terminals intact?</b> IAW AFMAN 32-1065, Section B, para. 9.4, and NFPA 780, Annex D, para. D.1.2 (4)									
		<b>Are braided bonding wires excessively frayed?</b> (cross-sectional area reduced by half) IAW AFMAN 32-1065, Section B, para. 9.5									
		<b>Are ground wires on the lightning protection masts damaged by lawn mowers or other equipment?</b> IAW AFMAN 32-1065, Section B, para. 9.6									
		<b>Are conductors and system components securely fastened to mounting surfaces?</b> IAW AFMAN 32-1065, Section B, para. 9.7, and NFPA 780, Annex D, para. D.1.2 (5)									
		<b>Have additions or alterations to the protected structure required additional protection?</b> IAW AFMAN 32-1065, Section B, para. 9.8, and NFPA 780, Annex D, para. D.1.2 (6)									
		<b>Do surge suppression (over voltage) devices appear damaged?</b> IAW AFMAN 32-1065, Section B, para. 9.9, and NFPA 780, Annex D, para. D.1.2 (7)									
		<b>Does the lightning protection system comply with applicable sections of NFPA 780 and AFMAN 32-1065?</b> IAW AFMAN 32-1065, Section B, para. 9.10, and NFPA 780, Annex D, para. D.1.2 (8)									
Is there a counterpoise grounding system							Test well ground resistance reading			<b>Ω</b>	
Soil condition on date of Inspection				Ambient Temp °F		Test reel resistance reading			<b>Ω</b>		
Continuity test from test well to static ground system / minus the test reel resistance											
Test Point	Resistance Reading	Test Point	Resistance Reading	Test Point	Resistance Reading	Test Point	Resistance Reading	Test Point	Resistance Reading	Test Point	Resistance Reading
1	<b>Ω</b>	15	<b>Ω</b>	29	<b>Ω</b>	43	<b>Ω</b>	57	<b>Ω</b>	71	<b>Ω</b>
2	<b>Ω</b>	16	<b>Ω</b>	30	<b>Ω</b>	44	<b>Ω</b>	58	<b>Ω</b>	72	<b>Ω</b>
3	<b>Ω</b>	17	<b>Ω</b>	31	<b>Ω</b>	45	<b>Ω</b>	59	<b>Ω</b>	73	<b>Ω</b>
4	<b>Ω</b>	18	<b>Ω</b>	32	<b>Ω</b>	46	<b>Ω</b>	60	<b>Ω</b>	74	<b>Ω</b>
5	<b>Ω</b>	19	<b>Ω</b>	33	<b>Ω</b>	47	<b>Ω</b>	61	<b>Ω</b>	75	<b>Ω</b>
6	<b>Ω</b>	20	<b>Ω</b>	34	<b>Ω</b>	48	<b>Ω</b>	62	<b>Ω</b>	76	<b>Ω</b>
7	<b>Ω</b>	21	<b>Ω</b>	35	<b>Ω</b>	49	<b>Ω</b>	63	<b>Ω</b>	77	<b>Ω</b>
8	<b>Ω</b>	22	<b>Ω</b>	36	<b>Ω</b>	50	<b>Ω</b>	64	<b>Ω</b>	78	<b>Ω</b>
9	<b>Ω</b>	23	<b>Ω</b>	37	<b>Ω</b>	51	<b>Ω</b>	65	<b>Ω</b>	79	<b>Ω</b>
10	<b>Ω</b>	24	<b>Ω</b>	38	<b>Ω</b>	52	<b>Ω</b>	66	<b>Ω</b>	80	<b>Ω</b>
11	<b>Ω</b>	25	<b>Ω</b>	39	<b>Ω</b>	53	<b>Ω</b>	67	<b>Ω</b>		<input type="checkbox"/>
12	<b>Ω</b>	26	<b>Ω</b>	40	<b>Ω</b>	54	<b>Ω</b>	68	<b>Ω</b>		<input type="checkbox"/>
13	<b>Ω</b>	27	<b>Ω</b>	41	<b>Ω</b>	55	<b>Ω</b>	69	<b>Ω</b>		<input type="checkbox"/>

14	$\Omega$	28	$\Omega$	42	$\Omega$	56	$\Omega$	70	$\Omega$	<input type="checkbox"/>
Continuity test from test well to lightning protection system / minus the test reel resistance										
Test Point	Resistance Reading	Test Point	Resistance Reading	Test Point	Resistance Reading	Discrepancies or System Notes:				
1	$\Omega$	4	$\Omega$	7	$\Omega$					
2	$\Omega$	5	$\Omega$	8	$\Omega$					
3	$\Omega$	6	$\Omega$		$\Omega$					
Date of next visual inspection:							Date of next 24-month test):			
Technician / Inspector Signature:										
Facility Point of Contact & Phone Number:										
Printed Name / Signature / Date:										
Signature of inspection form certifies review and receipt of duplicate inspection form										

Figure A7.8. Sample Static Ground System Layout.

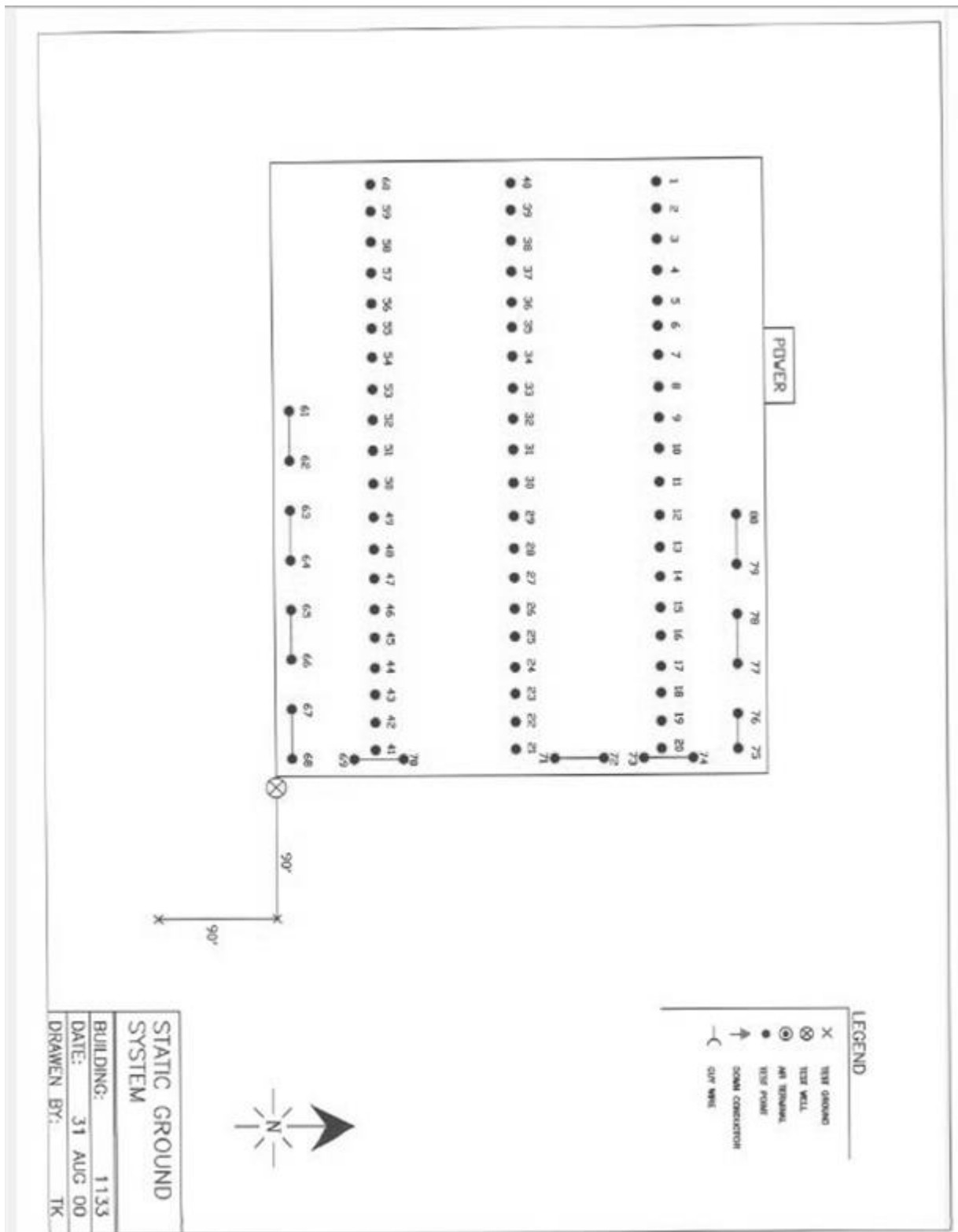


Figure A7.9. Sample Layout of Points for Catenary System.

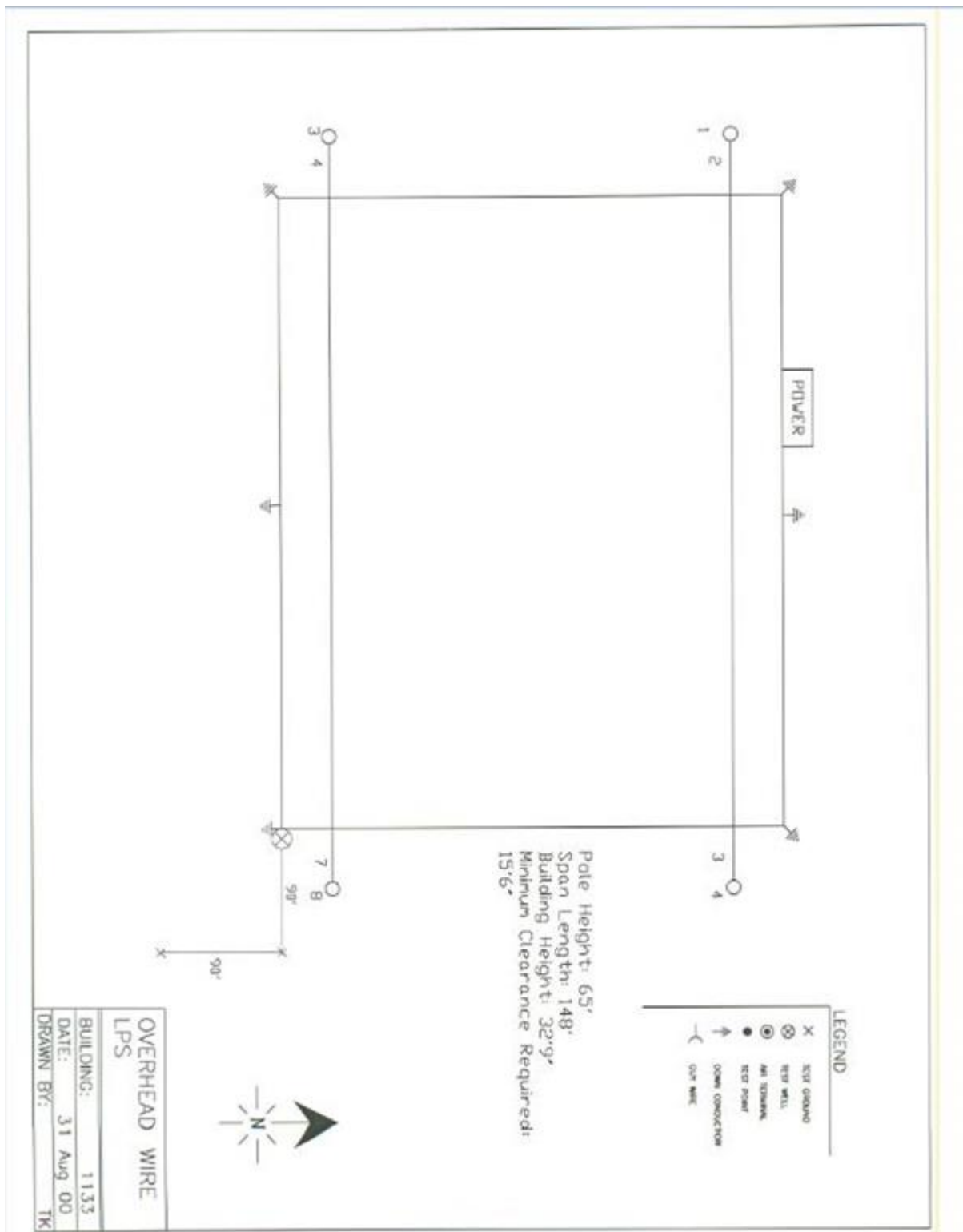
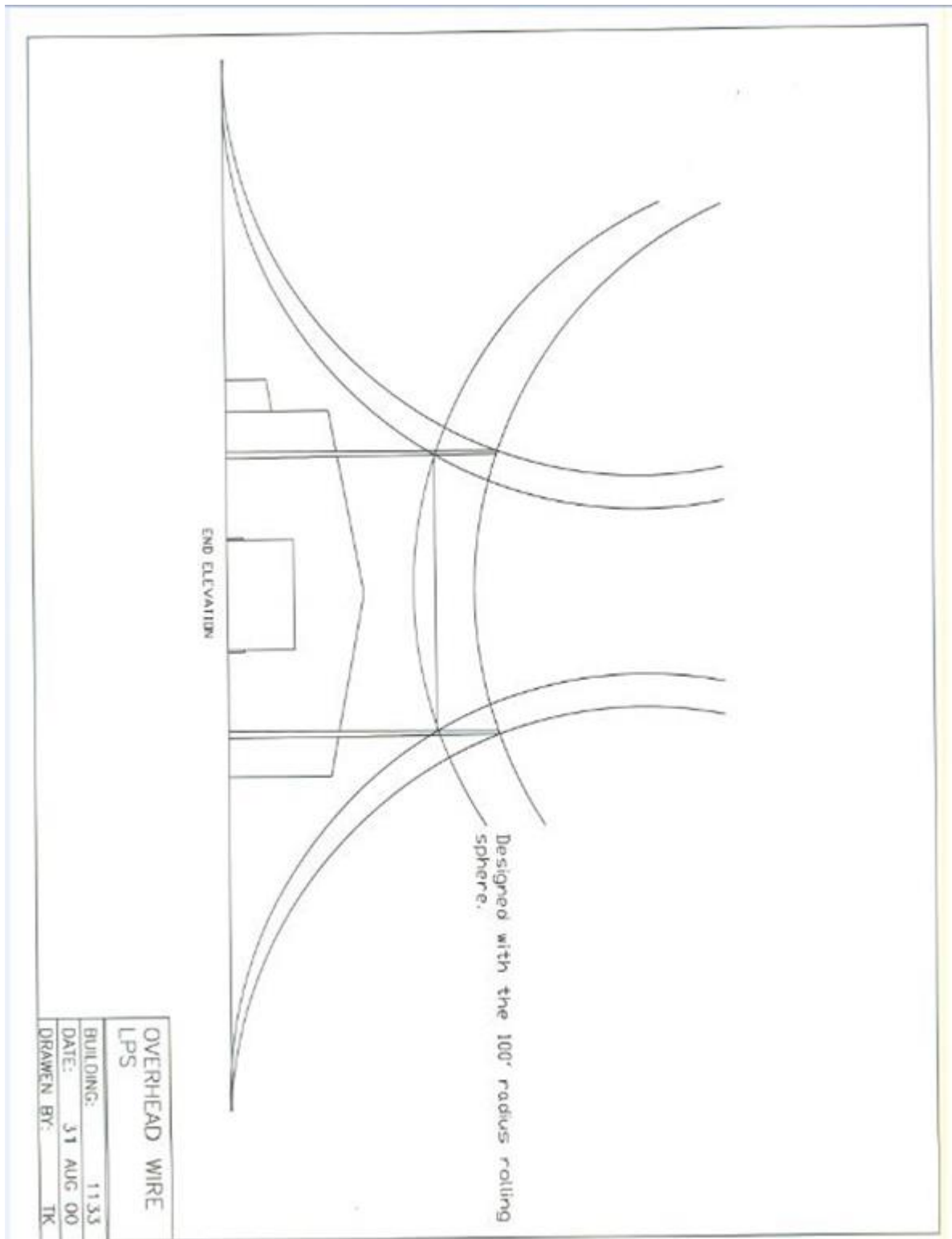


Figure A7.10. Sample Record for Projected Rolling Sphere Protection (100' is for Explosives Facilities – Non-explosives Facilities may be 150').



## Attachment 8

### REQUIREMENTS FOR WEAR OF MILITARY UNIFORMS WITH ARC THERMAL PERFORMANCE VALUE (ATPV) RATED PERSONAL PROTECTIVE EQUIPMENT (PPE)

**A8.1.** 3E0X1, 3E0X2, 3E1X1 and 3E4X1 personnel must comply with the following PPE and uniform requirements while working on or near energized circuits:

A8.1.1. Routine Electrical Work not Classified. The following PPE and uniform must be worn when performing Hazard/Risk Category 0 tasks: **(T-0)**.

A8.1.1.1. Safety glasses (ANSI Z87.1) with side shields or safety goggles (ANSI Z87.1) must be worn over metal frame and non-safety glasses. **(T-0)**.

A8.1.1.2. 100% cotton or natural fiber underwear (conventional short sleeve t-shirt and briefs/shorts) must be worn next to the body. T-shirts must not have any organizational or other insignias. **(T-0)**.

A8.1.1.3. Personnel must wear one of the following uniforms:

A8.1.1.3.1. NFPA-compliant 100% cotton ABU with sleeves rolled down. **(T-0)**. **Note:** ATPV-protective clothing is not required when wearing AFUB NFPA-compliant 100% cotton Airman Battle Uniform (ABU) while performing Hazard/Risk Category 0 tasks.

A8.1.1.3.2. 50% nylon/50% cotton ABU or Operational Camouflage Pattern (OCP) uniform and ATPV-rated protective shirt (long-sleeve) and pants (or ATPV-rated protective coveralls) with minimum arc rating of 8 cal/cm<sup>2</sup> (33.47 J/cm<sup>2</sup>). **(T-0)**. **Note:** When the 50% nylon/50% cotton ABU or OCP uniform is worn, the blouse must be removed before donning the ATPV protective clothing.

A8.1.1.4. Review NFPA 70E and UFC 3-560-01 for tasks requiring voltage-rated gloves with leather protectors. **(T-0)**.

A8.1.1.5. Electrical hazard-rated (EH) work shoes/boots. **(T-0)**.

A8.1.2. Hazard/Risk Categories 1 and 2. Personnel must wear the following PPE and uniform when performing Hazard/Risk Category 1 and Category 2 tasks:

A8.1.2.1. Safety glasses (ANSI Z87.1) with side shields, or safety goggles (ANSI Z87.1) worn over metal frame and non-safety glasses. **(T-0)**.

A8.1.2.2. Hearing protection using ear-canal inserts whenever working within the arc flash boundary. **(T-0)**.

A8.1.2.3. Balaclava/sock with minimum arc rating of 8 cal/cm<sup>2</sup> (33.47 J/cm<sup>2</sup>). **(T-0)**.

A8.1.2.4. Hard hat (ISEA Z89.1 Type 1 Class E approved). Long hair must be secured under the hard hat. For cold weather operations, insulated hard hat liner must be arc rated. **(T-0)**.

A8.1.2.5. Face shield with minimum arc rating of 8 cal/cm<sup>2</sup> (33.47 J/cm<sup>2</sup>) and wrap-around guarding to protect the face, forehead, ears, and neck. **(T-0)**.



<b>Routine Electrical Work not Classified</b>	100% Cotton ABU <sup>1</sup> (Coverall)			X		X	X			3			
	50/50 Blend ABU <sup>2</sup> or OCP Uniform <sup>2</sup>			X		X	X			3	X		
<b>1 &amp; 2</b>	100% Cotton ABU <sup>1</sup> (Coverall) or 50/50 Blend ABU <sup>2</sup> or OCP Uniform <sup>2</sup>	X	X	X	X	X	X	X	X	3	X		
<b>3</b>	100% Cotton ABU <sup>1</sup> (Coverall)	X	X	X	X	X	X			3		X	
<b>4</b>	100% Cotton ABU <sup>1</sup> (Coverall)	X	X	X	X	X	X			3			X
<b>Notes:</b>													
1. When wearing the 100% cotton ABU (coverall), sleeves must be rolled down.													
2. When wearing the 50/50 blend ABU or OCP uniform, the blouse must be removed.													
3. Voltage rated gloves with leather protectors must be worn in accordance with NFPA 70E and UFC 3-560-01.													