

**BY ORDER OF THE COMMANDER
SCHRIEVER AIR FORCE BASE**

**SCHRIEVER AIR FORCE BASE
INSTRUCTION 17-201**



5 APRIL 2021

Cyberspace

**C4 SYSTEMS
CONFIGURATION MANAGEMENT**

COMPLIANCE WITH THIS PUBLICATION IS MANDATORY

ACCESSIBILITY: Publications and forms are available for downloading or ordering on the e-publishing website at www.e-Publishing.af.mil

RELEASABILITY: There are no releasability restrictions on this publication

OPR: 50 CS/SCX

Certified by: 50CS/CC
(Lt Col. Shane Warren)

Supersedes: 50SWI17-201, 9 March 2020

Pages: 46

This instruction implements DAFPD 17-2, *CyberWarfare Operations*. This instruction applies to all *Regular Air Force and civilian government agencies and contractors* (as stipulated by contract) performing communications systems installations, modifications, or removals on Schriever Air Force Base (SAFB) and *the Air Force Reserve, Air National Guard (ANG) and to the United States Space Force and its SAFB Tenant Units*. Refer recommended changes and questions about this publication to the Office of Primary Responsibility (OPR) using the AF Form 847, *Recommendation for Change of Publication*; route AF Form 847s from the field through the appropriate functional's chain of command. Ensure that all records created as a result of processes prescribed in this publication are maintained in accordance with (IAW) Air Force Instruction (AFI) 33-322, *Records Management and Information Governance Program*, and disposed of IAW Air Force Records Information Management System (AFRIMS) Records Disposition Schedule (RDS). The use of a name or trademark of any specific manufacturer, commercial product, commodity, or service in this publication does not imply endorsement by the Air Force. This publication may not be supplemented or further implemented/extended. **Note:** In the event an installation proposal or a manufacturer's recommended specifications are in conflict with the requirements of this document, contact the 50th Communications Squadron (50 CS) Plans and Resources Flight (SCX) at 567-5842.

SUMMARY OF CHANGES

This document is substantially revised and must be completely reviewed. Updates reflect changes to applicability and Configuration Management Office policy and procedures. Outdated industry

standards have been eliminated and current standards referenced. Unnecessary information and requirements have been deleted. Chapter 5 and 6 have been removed. All prescribed forms have been removed.

Chapter 1—INTRODUCTION	4
Section 1A—Overview	4
1.1. Purpose.....	4
1.2. Scope.....	4
Section 1B—Installation Roles and Responsibilities.	4
1.3. General.....	4
Chapter 2—CONFIGURATION MANAGEMENT ENVIRONMENT	5
Section 2A—General.	5
2.1. Purpose.....	5
Section 2B—Utilidor.	5
2.2. General.....	5
Section 2C—Exterior Duct Banks and Underground Cables.	5
2.3. Cable Distribution.....	5
Section 2D—Physical Alterations to Facilities.	5
2.4. Alteration Policy for SAFB Facilities.....	5
Figure 2.1. SAFB Utilidor Layout.....	6
Figure 2.2. Typical 27 inch Under-floor Section. Note: Figure applicable to Building 400 and 700.....	7
Figure 2.3. Raised Floor Cutout and Trim.....	8
Figure 2.4. Typical Composite Sheet Installation.....	9
Section 2E—Equipment Placement.	11
2.5. General.....	11
Figure 2.5. Reinforcement Marking -2 Inch X 4 Inch.....	11
Section 2F—Mechanical System Standard.	12
2.6. General.....	12
Section 2G—Electrical Power Systems.	13
2.7. General.....	13
Figure 2.6. Conductor Color Code.....	15

Figure 2.7. Technical Power Receptacle Label..... 18

Section 2H—Grounding Standards. 18

 2.8. General..... 18

Section 2I—Communications Cable Installations. 20

 2.9. General..... 20

Figure 2.8. Intra-module Cable Routing for Administrative Communications (Building 400). 22

Table 2.1. Acceptable Cable Fire Rating Designators for SAFB. 23

Figure 2.9. Typical Cable Identification Tag Requirements. 28

Figure 2.10. Typical Identification Tag Locations. 29

Section 2J—Cable Conveyance Devices. 29

 2.10. General..... 29

Section 2K—Miscellaneous Installation Requirements. 31

 2.11. General..... 31

Figure 2.11. Unclassified Cable Tray Label (Black on White)..... 32

Figure 2.12. Fiber Optic Cable Tray Label (Black on Yellow)..... 32

Chapter 3—INSTALLATION/MODIFICATION AUTHORIZATION REQUEST REQUIREMENTS 35

 3.1. Scope..... 35

 3.2. Cyberspace Infrastructure Planning System (CIPS) Requirement..... 35

 3.3. Module Configuration Control. 35

Chapter 4—CABLE MANAGEMENT 36

 4.1. Request for Cable Routing and Cable Installation Data Sheet Process. 36

Attachment 1—GLOSSARY OF REFERENCES AND SUPPORTING INFORMATION 37

Attachment 2—REFERENCE DESIGNATOR SYSTEM 42

Attachment 3—RACK SPACE MANAGEMENT PROCESS 44

Attachment 4—SCHRIEVER AFB RACK ENCLOSURE STANDARD 45

Chapter 1

INTRODUCTION

Section 1A—Overview

1.1. Purpose. This document outlines the specific electrical, mechanical and structural standards that alterations, modifications and installations of communications systems must follow. A Cyberspace Infrastructure Planning System (CIPS) request shall be submitted for all Base Operating Support (BOS) requirements, circuit action requests and for cable routing of mission systems. By implementing these standards, SAFB shall be able to maintain safe installations and accurate documentation of those installations. BOS includes NIPR, SIPR and voice services.

1.2. Scope. A wide spectrum of standards and directives apply to agencies that perform installations on SAFB. In the event of conflict between this publication and other standards, the document with the strictest requirement, as determined by the 50th Communications Squadron, shall prevail.

Section 1B—Installation Roles and Responsibilities.

1.3. General. Various agencies have certain responsibilities for technical equipment installations. The responsibilities described below are pertinent to this document.

1.3.1. 50th Communications Squadron (50 CS) Plans and Programs Office. Responsibilities of the Plans and Programs Office include:

1.3.1.1. Coordination of request for NIPR/SIPR/Voice equipment installations or modifications and circuit actions/long-haul communications circuit requests.

1.3.1.2. Coordination of requests for cable installation/modification for mission systems.

1.3.2. Modification Requesting Agencies . Each requesting agency shall accomplish the following prior to performing any installations, de-installations, or modifications of NIPR/SIPR/Voice systems or long-haul communications circuits. Requests for deviation from the requirements described in this document shall be submitted to the Plans and Programs Office (50 CS/SCXP) at 567-3472.

1.3.2.1. Submit a CIPS request to 50 CS/SCXP for any installation or modification that requires NIPR/SIPR/Voice or cabling to support a mission system installation. If CIPS access is not available, contact the 50SCS.SCXP.ProjectManagement@us.af.mil email org box.

1.3.2.2. Coordinate planned installations with the SAFB Emissions Security (EMSEC) Manager, 50 SCS/SCXS. IAW Air Force Systems Security Instruction (AFSSI) 7702, *Emission Security Countermeasures Review*. It is the requester's responsibility to ensure their facility meets established EMSEC criteria.

1.3.2.3. Coordinate all structural, electrical power additions/modifications, and physical building requirements with 50th Civil Engineer Squadron (CES).

1.3.2.4. Ensure that the installing agency marks and labels communication cables with numbers assigned by the 50th Communications Squadron engineering section.

Chapter 2

CONFIGURATION MANAGEMENT ENVIRONMENT

Section 2A—General.

2.1. Purpose. This chapter describes the general environment and standards that are uniformly applied to facilities throughout SAFB.

Section 2B—Utilidor.

2.2. General. The utilidor (illustrated in [Figure 2.1](#)) is used primarily for installation and distribution of communications cables and utilities between Buildings 300, 301, 400, 401, 403, 500, 600, and 720. Conduit and cable trays have been provided in the utilidor to support installation of communications cables.

Section 2C—Exterior Duct Banks and Underground Cables.

2.3. Cable Distribution. Distribution of communications and utility lines between buildings and facilities not connected by the utilidor will be routed, at engineering's direction, through the utilidor to the exterior manhole or hand-hole duct bank system. Cables extending from the SAFB duct bank shall be installed per Base Civil Engineer (BCE) and this documents specifications.

Section 2D—Physical Alterations to Facilities.

2.4. Alteration Policy for SAFB Facilities.

2.4.1. Raised-Floor Penetrations. Raised-floors are provided in technical equipment areas to facilitate cable routing and cooling air distribution. [Figure 2.2](#) illustrates the typical under-floor configuration in Building 400. All penetrations, to include floor registers, are not to be moved or changed without approval of the Module manager.

2.4.1.1. Penetration Criteria. Openings in the raised-floor shall be made only after coordination and approval of Module manager.

Figure 2.1. SAFB Utilidor Layout.

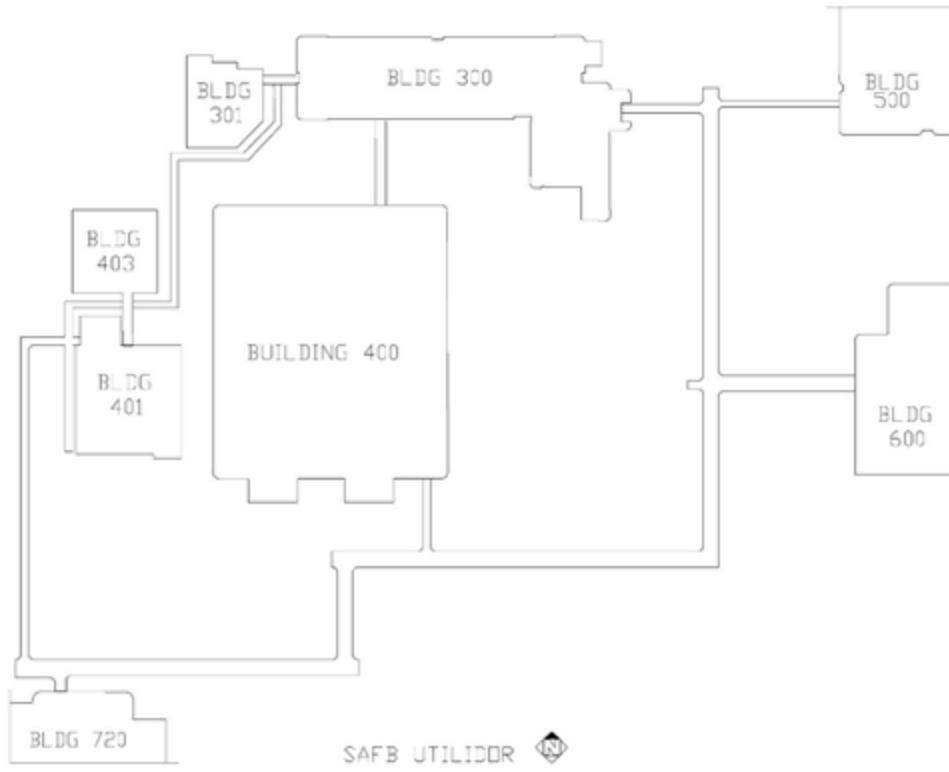
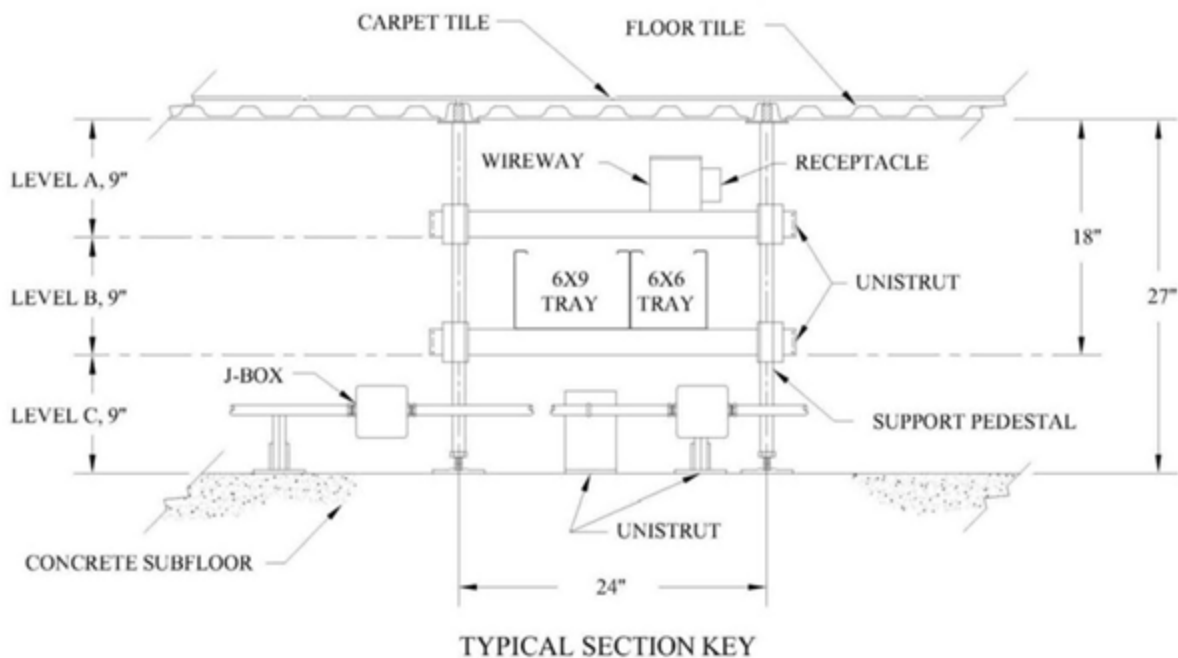

Figure 2.2. Typical 27 inch Under-floor Section. Note: Figure applicable to Building 400 and 700.



Note: The area beneath the raised floor grid is shown in three (3) horizontal layers each approximately 9 inches deep. Level "A" extends downward from the underside of the raised flooring approximately 9 inches. Level "B" continues beneath level "A" to the depth of approximately 18 inches. Level "C" continues beneath level "B" to the concrete sub-floor, approximately 27 inches below the raised floor.

Level "A" is reserved for power wireways and receptacles.

Level "B" is reserved for signal cable conveyances.

Level "C" is reserved for ground extensions, power distribution in conduits (feeders from main to subpanels and from wireways to receptacles) and administrative communications cables routed in "D" rings.

When installing site preparation requiring deviation from the above standard, submit a written requests to the applicable Mod Manager. Transitions between levels to avoid obstructions may be made without a written request.

2.4.1.2. Penetration Requirement. Raised-floor openings shall be reinforced per manufacturer's recommendations to preserve floor-loading characteristics and to prevent adverse impacts to the Air Conditioning (AC) system. Raised-floor cutouts and/or floor penetrations shall be sealed with an approved material to prevent dusting of the exposed concrete core and lined with a material suitable to cover exposed sharp edges and provide protection to cable or other hardware passing through the opening. (Rubber-coated flex conduit may be used without this lining, as the conduit will provide adequate protection.)

All openings shall be sealed with an Underwriter's Laboratory (UL)-listed material, applied per manufacturer's specifications, to prevent degradation of the AC system (i.e., intumescent composite sheet with putty, putty alone, fire sealant expanding foam, or other Air Force approved material). The use of a properly applied UL-sealant will ensure AC pressure is not adversely impacted. Neoprene (synthetic rubber) is not an acceptable material. **Figure 2.3** depicts a typical treatment of edges on a raised-floor opening. **Figure 2.4**, depicts the installation of a typical composite sheet material.

2.4.1.3. Reconstruction. In the event that maintenance or work is performed that requires the raised-floor system to be disrupted, it is the responsibility of the performing agency to return the raised-floor system back to its original configuration immediately after the work is complete.

Figure 2.3. Raised Floor Cutout and Trim.

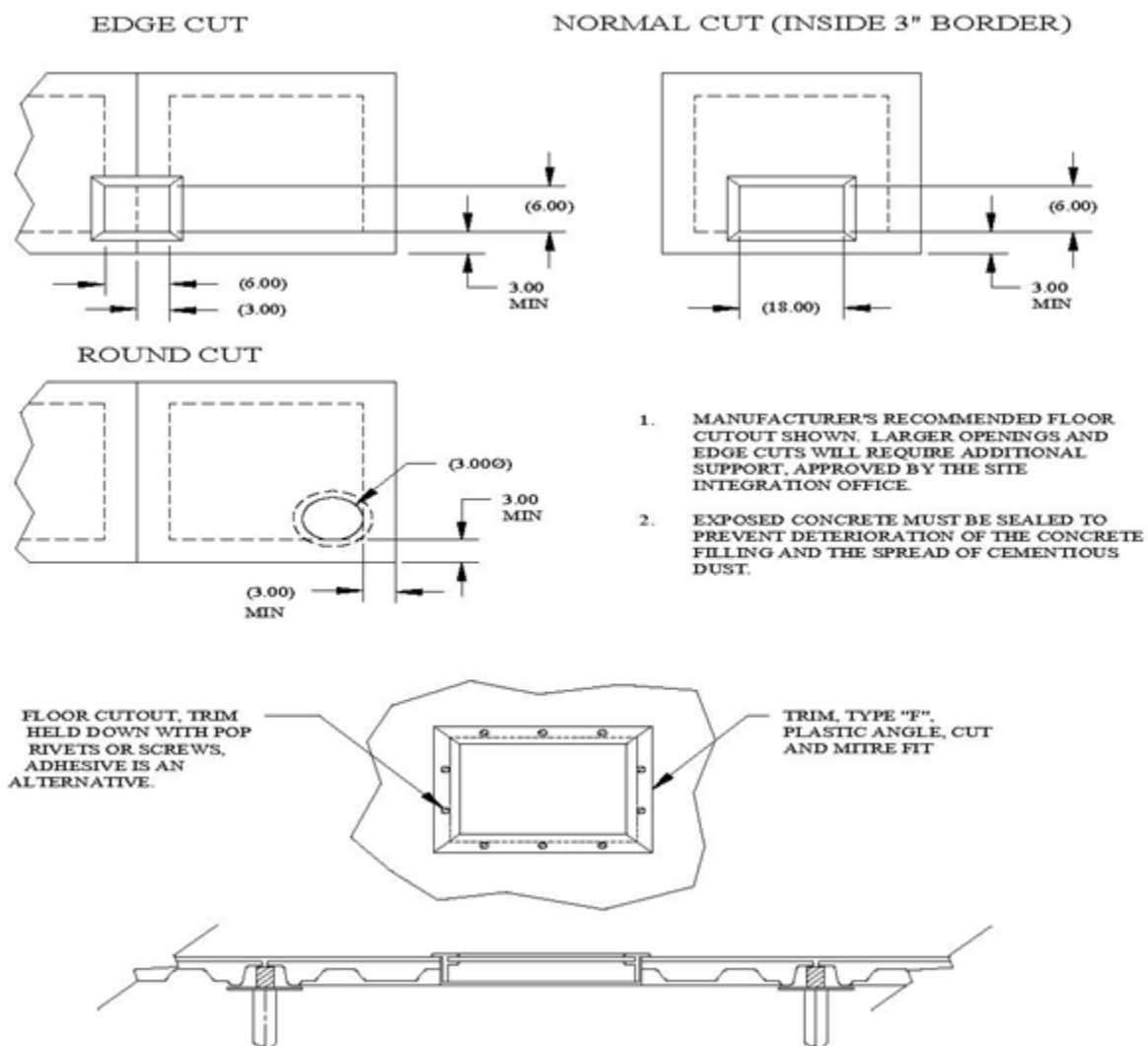
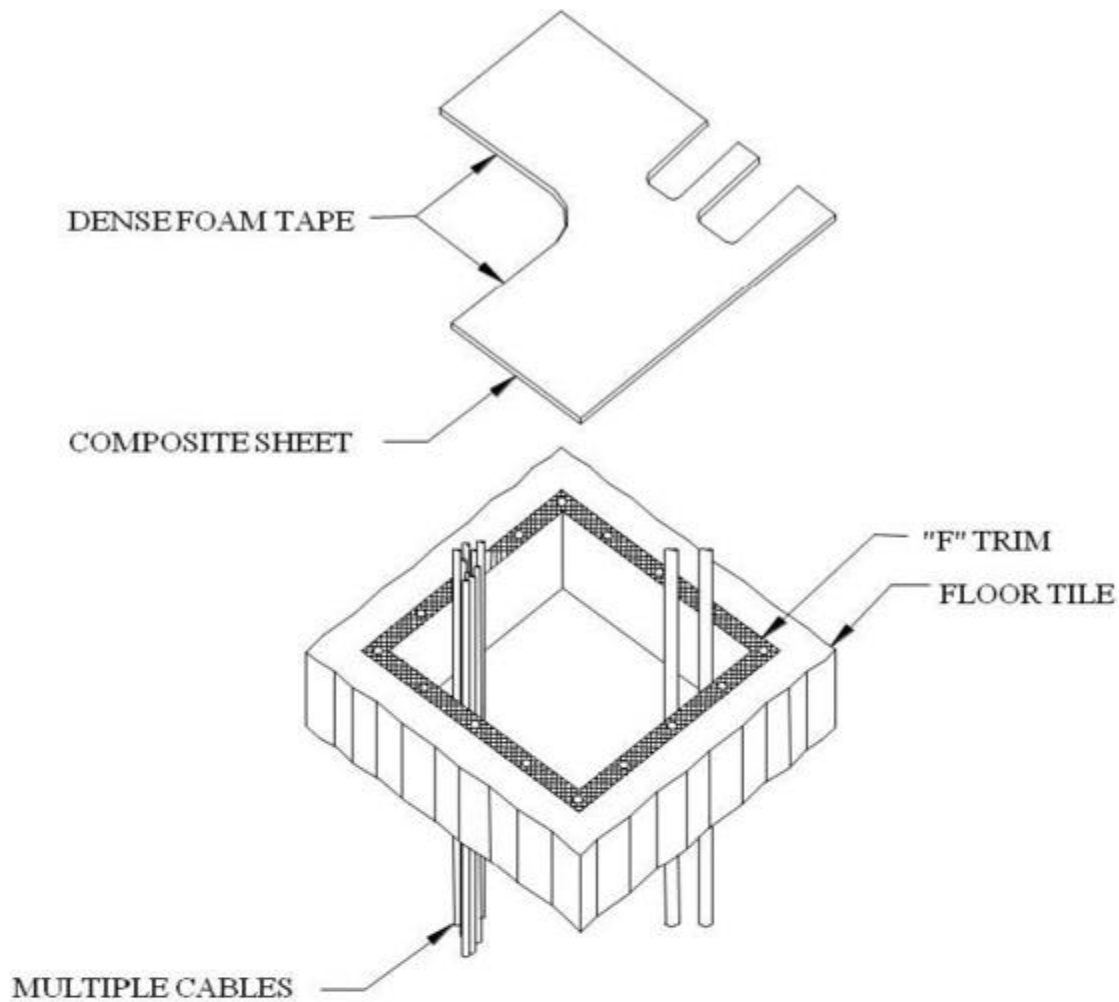

Figure 2.4. Typical Composite Sheet Installation.



TYPICAL COMPOSITE SHEET INSTALLATION

Note:

1. Any rubber inserts that exist are to be removed from the cable opening.
2. If possible arrange cables together. If cables cannot be arranged together, leave them in place.
3. Sheet should be cut to overlap the cable opening by two inches if possible. The cable holes in the sheet should be cut a minimum of one inch larger than necessary to allow for future cable expansion.
4. Install "F" trim around the perimeter of the cable opening as shown above. Trim is held down with pop rivets or screws. Adhesive is an alternative.
5. Place composite sheet foil side down inside the "F" trim slot with a bead of moldable putty applied around the edges. To seal Electro-Magnetic Interference (EMI) or Radio Frequency Interference (RFI) racks use a silicone adhesive to secure composite sheet to the bottom of the rack.
6. Apply the dense foam tape around all the rough cut-out edges to protect the cable.
7. After the composite sheet is in place fill all remaining openings/gaps with moldable putty to obtain a snug fit around the cables and complete the seal.

2.4.2. Firewall Penetrations. Installing agencies are responsible for ensuring that firewall integrity is maintained when penetrating for communications or power cables. There are three approved methods to penetrate unshielded firewalls: Multi-Cable Transit (MCT) devices, Compression Fittings, and Conduit Penetrations. These methods are described below:

2.4.2.1. Multi-Cable Transit. The Nelson MCT (also known as Nelson Window) is an example of MCT penetration device permitted at SAFB. Other MCTs that meet the rating of the penetrated firewall may be used. MCTs are normally rated for a two-hour firewall. At SAFB, the primary use of MCT is to provide cable penetration between the vertical and horizontal cable chases. MCTs may be used when penetrating through a gypsum firewall where numerous cable changes are anticipated. All penetrations must be capped by the installing or removing agency when not in use.

2.4.2.2. Compression Fitting (CF). The Crouse-Hinds Sealing Gasket Assembly and the Service Entrance Cable Connector are examples of CFs permitted at SAFB. Other CFs that have a one-hour fire rating may be used. CFs are used when penetrating metal windows located between the horizontal cable chases and the under-floor areas of the modules/rooms. Flame Seal II Putty, manufactured by Nelson Electric Supply or equivalent shall be used at the fitting if a complete seal cannot be accomplished. The manufacturer's instructions shall be followed when using CFs.

2.4.2.3. Conduit Penetration (CP). Only rigid conduit or electrical metallic tubing (EMT), as specified in this document, shall be used. CPs are used for penetrations through gypsum firewall. The procedures for making and sealing these penetrations are:

2.4.2.3.1. Cut a hole in the firewall approximately one-inch larger than the diameter of the conduit.

2.4.2.3.2. Pack fiberglass insulation into the gap around the conduit.

2.4.2.3.3. Use tape to hold the fiberglass insulation in place. Putty or caulk over the tape to complete the seal. **NOTE:** For under-floor firewall penetrations Flame Seal II Putty or equivalent may be used as a substitute for the fiberglass, tape, and putty/caulk as described above.

2.4.2.3.4. Use Flame Seal II Putty or equivalent to completely seal around the cables in one end of the rigid conduit or electrical metallic tubing.

2.4.2.3.5. Unused Penetrations. Unused penetrations made by means of a wave guide, bulkhead connector or other device shall be capped or covered to prevent loss of under-floor cooling air.

2.4.3. Additional Requirements for Penetrating Firewalls. Individual programs must meet Telecommunications Electronics Material Protected from Emanating Spurious Transmissions (TEMPEST) requirements IAW Air Force Cryptologic Systems Group guidance.

2.4.4. Shielded Area Penetration Criteria. Cables that penetrate a shielded area shall do so in a way that shall minimally degrade the physical integrity of the shield. Every penetration shall have its design submitted to 50 CS/SCXP for review and approval prior to installation. Installations shall comply with National Fire Protection Association (NFPA) 70, *National Electrical Code*, Article 300.21, AFSSI 7702, *Emission Security Countermeasures Reviews*, and NFPA 75, *Standard for the Protection of Information Technology Equipment*.

Section 2E—Equipment Placement.

2.5. General. Guidelines and requirements for equipment and systems furniture placement are outlined in this section.

2.5.1. Movable Partitions and System Furniture Walls . Modular partition walls and system furniture walls generally subdivide technical/mission areas and modules. Re-location of movable partitions and system furniture walls shall not be made until a plan for reconfiguration has been submitted to and coordinated with BCE Architect and SAFB Safety. Drawings for the system furniture shall include panel sizes, powered panels, non-powered panels, and power feed locations.

2.5.1.1. Equipment and System Furniture Layout. The agency having Modification Control Board (MCB) authority for an area or module approves the allocation of floor space within that area and ensures Work Space Clearance within the design.

2.5.1.2. Countermeasure Level. Each module or room at SAFB that processes classified information has an established countermeasure level. The countermeasure level, assigned by the base EMSEC manager, may restrict the placement of equipment, telephones, and cables. Equipment placement must meet RED/BLACK separation requirements. All locations shall comply with the requirements of AFSSI 7702.

2.5.2. Floor Loading. Equipment shall not impose floor loads that exceed the allowable loads for raised and non-raised floors in the baseline areas.

2.5.2.1. Raised-Floor Areas. The maximum floor loading on tiles in raised-floor areas shall not exceed manufacturer's recommendation. Where individual equipment loads exceed manufacturer's recommendation, or when several pieces of heavy equipment are located in close proximity, additional under-floor bracing shall be added. Four, five, and six-drawer safes shall have floor reinforcement. Safes and equipment that require floor reinforcement shall be labeled IAW **Figure 2.5**.

Figure 2.5. Reinforcement Marking -2 Inch X 4 Inch.

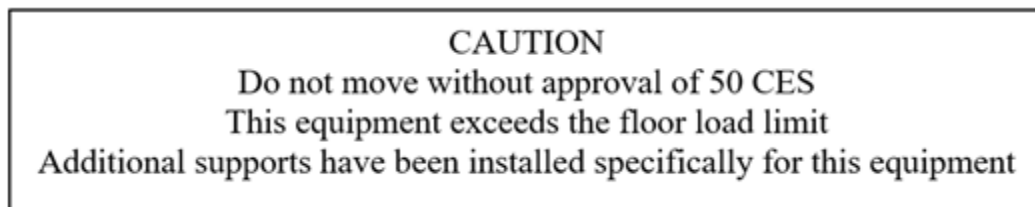

2.5.2.2. Concrete floor slabs that support raised floors shall not be loaded in excess of BCE recommendations.

2.5.2.3. Non Raised-Floor Areas. The maximum floor loading in non-raised-floor areas shall be determined by BCE. **NOTE: From 50 CES:** If 50 CES cannot support the structural evaluation, the requesting organization must provide funding to allow 50 CES to obtain a third-party structural engineer assessment or obtain a professional engineer stamped structural evaluation, which will be submitted to and approved by 50 CES.

2.5.3. Communications Rack Installation Tolerances. Racks shall be installed plumb, aligned and anchored. For grounding and bonding requirements see [paragraph 2.8.2](#) (See [Attachment 3](#) for rack space management process and [Attachment 4](#) for standard rack configuration.)

2.5.4. Overhead Equipment. The structural steel beams above the suspended ceiling shall support equipment requiring overhead mounting (i.e. Time Display Units or video monitors). Ceiling support wires or the suspended ceiling grid will not be used to support the overhead equipment including cable trays and conduits. Cable trays, conduits, and raceways shall be installed, bonded, and grounded IAW Military Standard (MIL-STD)-188-124B, *Grounding, Bonding and Shielding*, paragraphs 5.1.1.2.4.1 and 5.1.1.2.4.2. 50CES approval is required before anything is hung from any structural member. If 50 CES cannot support the structural evaluation, the requesting organization must provide funding to allow 50 CES to obtain a third-party structural engineer assessment or obtain a professional engineer stamped structural evaluation, which will be submitted to and approved by 50 CES.

2.5.5. Safety Requirements.

2.5.5.1. Equipment Layout. To ensure a safe working environment, communications cables, power wiring, and ancillary cables that penetrate raised floors shall do so entirely within the footprint of the respective equipment rack.

2.5.5.2. Unistrut End Cap Covers. Under-floor unistruts shall have end cap covers installed to protect against sharp edges.

2.5.5.3. All equipment and system furniture installations shall comply with NFPA 101, *Life Safety Code* and MIL-STD-1472G, *Human Engineering*.

Section 2F—Mechanical System Standard.

2.6. General. This section provides an overview of environmental systems. Environmental, alarm, and fire suppression systems are controlled by BCE. Coordinate all installations which may impact these systems with BCE.

2.6.1. Interior Environmental Condition. Data-processing equipment areas are provided with a controlled internal environment to meet equipment operating specifications and ensure reliable equipment operation. The module areas in Building 400 and 700 use pressurized, raised-floor plenum systems to deliver cooling air for specific data-processing equipment. Technical equipment in other areas normally receive cooling air from overhead systems.

2.6.1.1. Environmental Parameters. Air conditioning systems in data-processing equipment areas are provided to satisfy equipment cooling requirements rather than creature comfort and shall maintain the environmental parameters as required to support installed equipment.

2.6.1.2. Due to the criticality of airflow in Building 400 and 700 modules, see [paragraphs 2.11.3, 2.11.4, and 2.11.5](#) for floor tile removal guidelines. These constraints may be relaxed if suitable air dams are approved by BCE or if non-impact to under-floor cooling in the module can be demonstrated.

2.6.2. Under-floor Air Distribution System.

2.6.2.1. General Description. Conditioned air is supplied by a combination of variable air-volume overhead and under-floor air-handling units. Computer room air conditioning units are used only where the capacity of the under-floor air-handling unit is not adequate. Airflow from an under-floor plenum varies in response to a thermostat; air-volume controlled pneumatic or electrically operated dampers on the floor air registers as described in 2.4.1.2.

2.6.3. Fire Suppression, Detection, and Alarm Systems and Devices.

2.6.3.1. General Description. In general, current fire suppression is provided by a wet-pipe or pre-action sprinkler system. A hose connection for fire department use only is provided for additional fire suppression capability. All work affecting fire suppression, detection, and alarm systems and devices must be approved by BCE.

2.6.3.2. Sprinkler System Alterations. Alterations or extensions to existing sprinkler systems in any area shall be in strict accordance with Alterations to an existing sprinkler system shall be in accordance with Uniform Fire Code (UFC) 3-600-01, *Fire Protection Engineering For Facilities* and must be certified by a licensed professional Fire Engineer. 50 CES does not employ a licensed professional Fire Engineer so funding must be provided by the Requestor to support 50 CES obtaining this engineer certification of the system.

2.6.3.3. Detection/Alarm System.

2.6.3.3.1. Alterations. Alterations to an existing fire alarm system shall be in accordance with UFC 3-600-01.

2.6.3.3.2. Affected Devices. As area expansions or renovations take place, including changes to floor-to-ceiling partition walls and systems furniture, consideration must be given to the necessity of relocating or installing any of the following:

2.6.3.3.2.1. Emergency Power Off or Air Power Off switches.

2.6.3.3.2.2. Emergency Egress Lighting.

2.6.3.3.2.3. Sprinkler Heads.

2.6.3.3.2.4. Heat and smoke detectors.

2.6.3.3.2.5. Fire alarm pull stations.

Section 2G—Electrical Power Systems.

2.7. General. This section provides specific SAFB technical and technical support power requirements and standards. Installations shall be IAW NFPA 70. (Only 50 CES is authorized to execute work to make changes to any aspect of the electrical system or electrical power configuration).

2.7.1. Technical Power System (TPS) Characteristics, Alternating Current (AC), and Direct Current (DC) Systems.

2.7.1.1. TPS AC System.

2.7.1.1.1. General Description. The TPS AC system supplies electrical power to critical equipment loads. The critical loads require uninterrupted, regulated power at 60 Hertz (Hz), and are provided power from an Uninterruptible Power System (UPS).

2.7.1.1.2. System Characteristics. UPS power characteristics are as follows:

2.7.1.1.2.1. Nominal Voltage: 120/208V, 3-phase, and 4-wire with ground

2.7.1.1.2.2. Frequency: 60.0Hz

2.7.1.1.2.3. Voltage Regulation: $\pm 2\%$ with 50% phase unbalanced

2.7.1.1.3. Distribution System. In the TPS AC system, power is distributed from floor or wall-mounted main panels to wall-mounted sub-panels via an approved raceway. From sub-panels, individual conductors are brought via an approved raceway to power receptacles or junction boxes for direct connections. Under-floor electrical receptacles will be isolated ground twist-lock type.

2.7.1.1.4. Load Balancing. All loads shall be balanced to the maximum extent possible to minimize current flow in the neutral conductor.

2.7.1.1.5. Load Criteria. The voltage from the TPS system shall not be connected to any motor generator, motor, or other rotating machine. The exceptions to this rule are the equipment rack fans for equipment racks or computer peripheral equipment.

2.7.1.2. TPS DC System.

2.7.1.2.1. General Description. The TPS DC system supplies electrical power to critical communication equipment loads. The communication critical loads require uninterrupted, regulated power at -48 Volts DC, and are provided power from AC-to-DC rectifiers and backup batteries. Installations shall be IAW Technical Order (TO) 31Z-10-22, *Electrical Power Systems For Telecommunications Facilities*.

2.7.1.2.2. Distribution System. In the TPS – 48 Volt DC system, power is distributed from rack mounted main panels to rack mounted sub-panels via an approved raceway. From sub-panels, individual negative (–) and positive (+) conductors are brought via an approved raceway to end communication equipment loads for direct connection, or to fused distribution units within the communication equipment racks.

2.7.1.2.3. System Characteristics. The 48-Volt DC power characteristics are as follows: Nominal Voltage: 54 Volts DC, rectifier float voltage (normally supplies power load requirements and battery charging) 52 Volts DC, battery voltage – fully charged (supplies backup power load requirements). Circuit wiring is 2-wire; negative (–) and positive (+).

2.7.2. Technical Support Power System (TSPS) (Non-Technical Power) Characteristics.

2.7.2.1. General Description. The TSPS supplies electrical power to the essential facility loads. The normal power source is the local commercial utility. Standby Class B diesel generators provide backup utility power. The standby system is capable of meeting the power requirements of all critical and essential loads. Under-floor receptacles will be twist lock type.

2.7.2.2. Distribution and Load Balancing. The requirements of distribution and load balancing for TSPS power shall meet the criteria of 2.7.1.1.3, Distribution System with the exception isolated grounding is not required, and 2.7.1.1.4, Load Balancing for TPS is at time of installation.

2.7.2.3. Load Criteria. Most of the TSPS loads are motors and lighting that can tolerate momentary (in some cases extended) power outages without compromising the operational mission.

2.7.3. Classified Equipment Power.

2.7.3.1. Requirement. Electrical power for equipment processing classified information (RED) shall meet the installation criteria of AFSSI 7702.

2.7.4. Power Cables and Conductors.

2.7.4.1. Cable and Conductor Requirements. The distribution of power shall be by jacketed multi-conductor cable or individual conductors. Cables and conductors shall be installed and routed through approved raceways. Cables shall have a fully rated or oversized neutral and a ground wire. Cables and individual conductors shall meet the following requirements.

2.7.4.1.1. 600 volt rating.

2.7.4.1.2. Maximum operating temperature of at least 90 Centigrade (194 F).

2.7.4.1.3. Suitable for damp or dry locations.

2.7.4.1.4. Flame retardant and heat-resistant thermoplastic insulation.

2.7.4.2. Conductor Color Code. Power conductors of a standard “wye” configuration shall be color coded as follows:

Figure 2.6. Conductor Color Code.

120/208V	277/480V
Phase A – Black	Phase A – Brown
Phase B – Red	Phase B – Orange
Phase C – Blue	Phase C – Yellow
Neutral – White	Neutral – Gray or White
Ground – Green	Ground – Green

2.7.5. Power Distribution Systems.

2.7.5.1. Local Power Distribution. Floor-mounted or wall mounted power distribution panels shall be installed for the purpose of providing localized power distribution. The physical location of such power distribution systems shall be determined by the installing agency. Each distribution system should be as close to the loads it serves as possible.

2.7.5.1.1. TPS and TSPS power conductors (feeders and branch circuits) shall not be installed in the same conduit, wireway, or raceway.

2.7.5.2. Local Power Distribution Identification. Main and sub-panels shall be labeled with the panel number as assigned by 50 CES.

2.7.5.3. Sizing/Loading Policy for 60Hz Systems (TPS and TSPS). To ensure standardization of the National Electric Code (NEC) interpretations for sizing and loading the TPS and TSPS panels, the following criteria shall apply:

2.7.5.3.1. Panel main breakers shall be sized to properly handle load connected to the panel.

2.7.5.3.2. Panel distribution breakers shall be sized to properly handle load connected to the panel.

2.7.5.3.3. Distribution breakers from the main panel to the sub-panels shall be rated equal to or greater than the sub-panel main breaker.

2.7.5.3.4. All new panels shall be sized at to properly handle load connected to the panel, plus an additional 25 percent for future growth. Cumulative nameplate loads will be used to determine if the breaker has the power available to supply connected load

2.7.5.3.5. Neutral Conductor Wire Sizing For All Non-Linear Loads

2.7.5.3.5.1. Feeder neutral conductors for main panels shall be measured at least once every two years for a minimum period of two days to ensure neutral currents do not become excessive due to additive harmonic currents. Sub-panel neutral currents shall be measured for a minimum period of one day.

2.7.5.3.5.2. In an effort to avoid over-currents on the neutral conductor, the neutral shall be at least the same size as the ungrounded circuit conductors.

2.7.5.4. Molded Case Circuit Breakers.

2.7.5.4.1. The power distribution system shall be provided with molded case circuit breakers sized IAW the NEC for their assigned loads. Newly installed breakers shall be rated at 20 amps or larger. These circuit breakers shall be of the same type and manufacturer as those in the power panels. Circuit breakers and load receptacles shall comply with **Table 210.21(B) (3)** of the NEC. Circuit breakers shall have thermal-magnetic trips. **EXCEPTION:** Circuit breakers rated at 15 amps are allowed when used to comply with the equipment manufacturer's requirements.

2.7.5.4.2. Circuit Breaker Spares. Provisions shall be made for 25 percent spare breakers or space for breakers for new installations.

2.7.5.5. Branch Circuit Receptacles.

2.7.5.5.1. Selection. Branch circuit receptacles shall comply with the NEC for 20 amp or larger circuit breakers. **EXCEPTION:** Single 15 amps receptacles are allowed when used to comply with the equipment manufacturer's requirements.

2.7.5.6. Circuit Identification.

2.7.5.6.1. Panel Schedule. The panel schedule information shall consist of the room and equipment number (i.e.; 013/008-024) or a brief description of the room and equipment, number of poles, and circuit breaker size.

2.7.5.6.2. Additions/Modifications. Any addition or modification with respect to the loads of a power distribution system shall be legibly documented by the installing agency at the time of the modification. Updates shall be made on a schedule located inside of the panel cover. The information shall consist of the room number in which the equipment is located, the date the schedule was updated, and the equipment number (or brief description of the equipment).

2.7.5.6.3. Wire Labeling. Phase, neutral, and green ground wires within the baseline shall be labeled with the circuit number of the circuit breaker in the power panel from which the wires originate and at the destination terminations. The installing agency is responsible for labeling the conductors. When power panels are upgraded all conductors and circuit breakers will be properly labeled.

2.7.5.6.4. TPS Receptacle Marking. All TPS receptacles shall be labeled with the panel and circuit breaker numbers that serve the receptacle. The color of the label shall be orange with black lettering. See [Figure 2.6](#) for typical examples of TPS receptacle labels. The installing agency is responsible for labeling the receptacles.

2.7.5.6.4.1. The receptacles are for mission essential equipment only; do not use for vacuums, lights, system furniture lights, or table top lamps.

2.7.5.6.5. TSPS Receptacle Marking. All TSPS receptacles shall be labeled with the panel and circuit breaker numbers that serve the receptacle. The color of the label shall be yellow with black lettering. The installing agency is responsible for labeling the receptacles. **EXCEPTION:** System furniture circuit labeling shall be at base-feed or top-feed junction. Wall mounted convenience receptacles do not require labeling.

2.7.5.6.5.1. The receptacles are for non-mission essential equipment.

2.7.5.6.6. Alternate Receptacle Marking Method. An acceptable alternate method for marking TPS and TSPS receptacles is the use of a label maker that produces a plastic tape, that when printed resists obliteration. The minimum size of tape shall be 3/4 inch and the lettering shall be black, minimum size 3/16 inch. The tape for TPS receptacles shall be orange and for TSPS receptacles it shall be yellow. (See [Figure 2.6](#) and [Figure 2.7](#)).

2.7.6. Electrical Requirements for System Furniture.

2.7.6.1. New Installations. New system furniture shall have an eight-wire (8-wire) or ten-wire (10-wire), wye configuration electrical system and shall be connected to individual 20 amp branch circuit breakers and shall also be limited to six (6) workstations per 3-phase systems furniture group and two (2) personal workstations per input phase. The wiring shall consist of a separate neutral conductor for each phase conductor and may share a ground conductor. Refer to the manufacturer's documentation for the exact wire configuration. The minimum wire size shall be #12 American Wire Gage (AWG) in support of a maximum 20-amp circuit breaker. The installation shall also meet the requirements listed below.

2.7.6.1.1. The installation shall not combine technical and non-technical power sources.

2.7.6.2. System Furniture Upgrades or Modifications. System furniture upgrades or modifications shall comply with the requirements of new installations, above. In the event the existing system furniture wiring does not have a separate neutral for each input phase conductor, then one of the following multi-wire circuit configuration upgrades shall be used.

2.7.6.2.1. All three input phases shall originate from a single multi-pole circuit breaker and the neutral shall be #10 AWG.

2.7.6.2.2. The three input phases shall be configured such that the location of the circuit breakers allows a single handle tie to physically connect all three circuit breakers. In the event one circuit breaker is tripped, all three circuit breakers shall trip. The neutral shall be #10 AWG.

2.7.7. Verification of New Installations or Major Modifications.

2.7.7.1. Verification. Upon completion of a new installation or major modification, the power and grounding system shall be verified and currents measured on the phase, neutral, equipment safety conductors, and/or connections to the Equipotential Ground Plane (EGP). CE WICS shall perform these verifications through submission an Electrical Request Form (ERF).

Figure 2.7. Technical Power Receptacle Label.

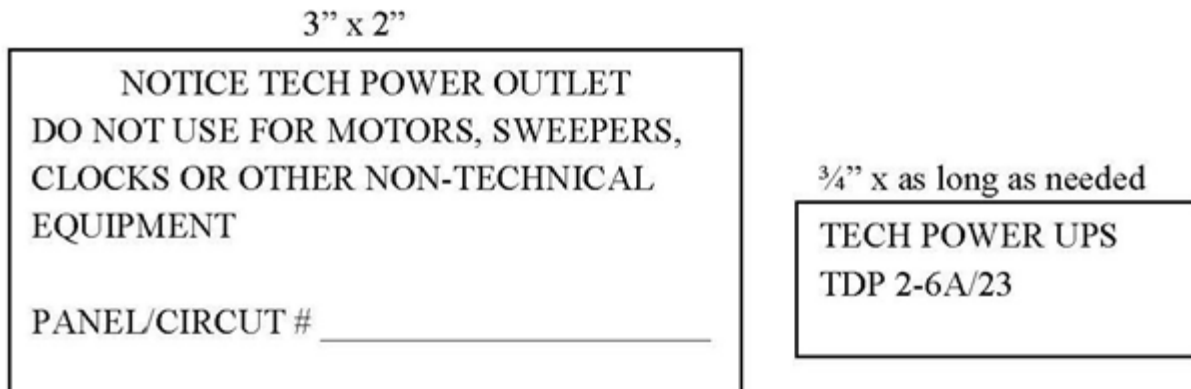

Section 2H—Grounding Standards.

2.8. General. This section provides SAFB grounding requirements.

2.8.1. Facility Provisions.

2.8.1.1. General Description. Each facility in the SAFB Configuration Baseline has been provided with grounding configurations as described below.

2.8.2. Grounding Design.

2.8.2.1. Conductors. All safety grounding conductors shall be insulated; colored green, green with yellow stripe, or marked green at each end; and sized IAW NFPA 70, Table 250.122. **EXCEPTION:** Cable Tray Systems, see [paragraph 2.8.5](#).

2.8.2.2. Connections. Bolting or screws able to maintain 1200-to-1500 psi between contact surfaces or welding at the termination shall connect the grounding conductor.

2.8.3. Derived AC Systems.

2.8.3.1. Grounded Neutral Conductor Bonding. The neutral of all derived AC systems shall be bonded to ground with an insulated conductor the same size or larger than the largest service or secondary conductor or #4 AWG, whichever is greater. Derived AC systems shall have their neutrals bonded at one point only; at the "XO" of the separately derived source or at the first system disconnect.

2.8.3.2. Isolated Ground Bus. Any isolated ground bus shall be independently connected to ground at the neutral-ground bond of the separately derived system or at the ground bus at the first disconnect of the separately derived system.

2.8.3.3. *Green-Wire Bus and Grounding. A safety, green-wire ground bus is required in each power distribution panel. If multiple ground buses are installed in the panel they shall be bonded together. This bonding shall be accomplished with a properly sized copper ground conductor. The enclosure shall not be used as a bonding conductor. All power feeders and branch circuits shall be installed with a safety green-wire grounding conductor run with the phase and neutral conductors. The copper safety green-wire grounding conductor shall be sized IAW NEC Table 250.122 and/or Military Handbook (MIL-HDBK)-419, Grounding, Bonding and Shielding for Electronic Equipment and Facilities, Table 1.21.. Aluminum or copper-clad aluminum wire shall not be used.*

2.8.3.4. Filter Grounding. The grounding conductor shall be bonded to the unfiltered and filtered sides of the filter box of a shielded area. Additionally, the grounding conductor on the filtered side shall be bonded to building steel. This configuration applies to all new construction and modifications of existing power cables in shielded areas.

2.8.4. Raised Floor System.

2.8.4.1. Requirement. A raised-floor system is a drop-in or removable grid system and shall not be used or supplemented as a safety, green-wire ground, or a signal reference ground.

2.8.5. Communications Cable Tray Systems.

2.8.5.1. Requirement. A bare #2 AWG copper conductor shall be installed throughout each cable tray system and connected with a mechanical clamp to the outside of each cable tray section. The tray system ground conductor shall be bonded to the facility ground.

2.8.6. Specialized Grounding Systems.

2.8.6.1. Requirement. The use of an Equipotential Ground Plane (EGP) has eliminated the need for specialized grounding systems. An EGP eliminates large differences in potential across the ground plane, whereas the use of specialized grounding systems can increase these differences. Specialized grounding systems should be avoided and consideration given to converting specialized systems to an EGP. If conversion to an EGP system is not possible, the specialized system design must be reviewed by 50 SW/SE for safety, security, and signal ground integrity. Final approval by 50 CES is required before installation.

2.8.7. Grounding Interconnections.

2.8.7.1. Shielded Areas. In shielded areas, all classes of grounding shall be terminated either on the ground plate or on the ground panels. The EGP may be used when the shortest possible grounding conductor length is required or when ultra-low noise audio grounding is required.

2.8.7.2. Unshielded Areas. In unshielded areas separate RED and BLACK grounds are provided for grounding. When an EGP is installed the RED and BLACK grounding panels/plates shall be electrically connected to each other and to the EGP.

2.8.7.3. EGP Applications. Per MIL-HDBK-419, where new grounding systems are to be installed or where the grounding system is to be converted from an existing Single-Earth Ground Point (SEGP) to an EGP, the installing agency must ensure the following:

2.8.7.3.1. The EGP scheme shall satisfy high and low frequency communications/electronics equipment applications.

2.8.7.3.2. Communications-Electronics equipment shall be grounded to the EGP IAW MIL-HDBK-419A, *Grounding, Bonding, and Shielding for Electronic Equipment and Facilities*.

2.8.7.3.3. Equipment racks/cabinets shall be connected to the EGP with a 2/0 conductor.

2.8.7.4. The EGP shall comply with MIL-HDBK-419A. In the event of a conversion from an existing ground system to an EGP, a ground system noise survey and a ground system differential noise voltage test shall be conducted before and after the technical ground system conversion IAW MIL-HDBK-419A. **NOTE:** BCE shall make measurements to ensure the integrity of the grounding systems is maintained after new equipment is installed or major modifications of equipment that connect to the grounding systems are complete.

Section 2I—Communications Cable Installations.

2.9. General. Unique SAFB communications cable installation standards are outlined in this section.

2.9.1. **Fiber Optic and Metallic Cables.** This section applies to fiber optic and metallic cables that are used for classified and unclassified data and voice communications and Local Area Networks (LANs) on SAFB. Only fiber optic cables with non-conductive characteristics (i.e. non-conductive jackets or strengtheners shall be permitted).

2.9.2. **SAFB Cable Distribution System.** The SAFB cable distribution system encompasses the cable conveyances includes cable chases and cable vaults, the utilidor between buildings, and the network of duct banks and manholes.

2.9.2.1. Cable Protection. Communications cables shall penetrate a wall in a manner that shall protect the cable from damage and maintain the fire rating of the wall. This may be done by using an insulated throat-type bushing or similar device, reference NFPA Article 300.21.

2.9.2.2. Installation Compliance. All communications cable installations shall comply with the 31-10 series T.O.s. All locations shall comply with AFSSI 7702 and National Security Telecommunications and Information Systems Security Advisory Memorandum (NSTISSAM) TEMPEST/2-95, *RED/BLACK Installation Guidance*.

2.9.2.3. Fiber Termination Compliance. Cables shall be terminated IAW 33-10 series T.O.s or local standard installation practice. All cables and strands shall be terminated with connectors and placed into patch panels or connected to peripheral equipment. Cable conductors shall be fanned out to match the color codes to which they are attached.

2.9.2.4. Communications Cable Distribution. The distribution of RED or BLACK communications cables, including administrative communication cabling, shall be by means of RED or BLACK cable tray or conduit conveyances. "D" ring conveyances may be used for BLACK only. When BLACK communications cables must be routed in the ceiling space, installation shall be in metal conduit or wireways (Refer to 2.9.3 for RED/BLACK separation information). Cables may penetrate sidewalls of equipment racks to provide routing between adjacent racks only. Grommets must be used when routing through equipment racks. Cables shall not be run on the surface of raised floors or under carpet tiles.

2.9.2.4.1. "D" Ring Installations. "D" rings may be used only as an extension of cable conveyances for unclassified metallic cables used for administrative communications service (i.e., unclassified telephone service and unclassified administrative LAN service). "D" rings shall only be used for routing from the cable conveyance to the end equipment location.

2.9.2.4.1.1. "D" rings shall be no longer than six inches and shall be installed at intervals not to exceed four feet.

2.9.2.4.1.2. Total cable length supported by "D" rings shall not exceed 40 feet.

2.9.2.4.1.3. "D" rings shall be firmly attached to the under-floor stanchions by using an appropriate fastener such as nylon cable tie wraps or stanchion clamps (wire, tape, or string are not considered appropriate). Trim excess ends flush with retainer. Reference: TO 31-10-13, *Air Force Communications Service (E-1 Standard) Standard Installation Practices, Cabling for Fixed Ground C-E-Equipment, Army Fm-487-19*.

2.9.2.4.1.4. "D" rings shall be installed in the lowest under-floor level, but not touch the floor.

2.9.2.4.1.5. Cable installed through "D" rings shall not be routed diagonally and shall use the minimum number of 90-degree bends. **Figure 2.8** depicts intra-module cable routing for administrative communications cabling.

Figure 2.8. Intra-module Cable Routing for Administrative Communications (Building 400).

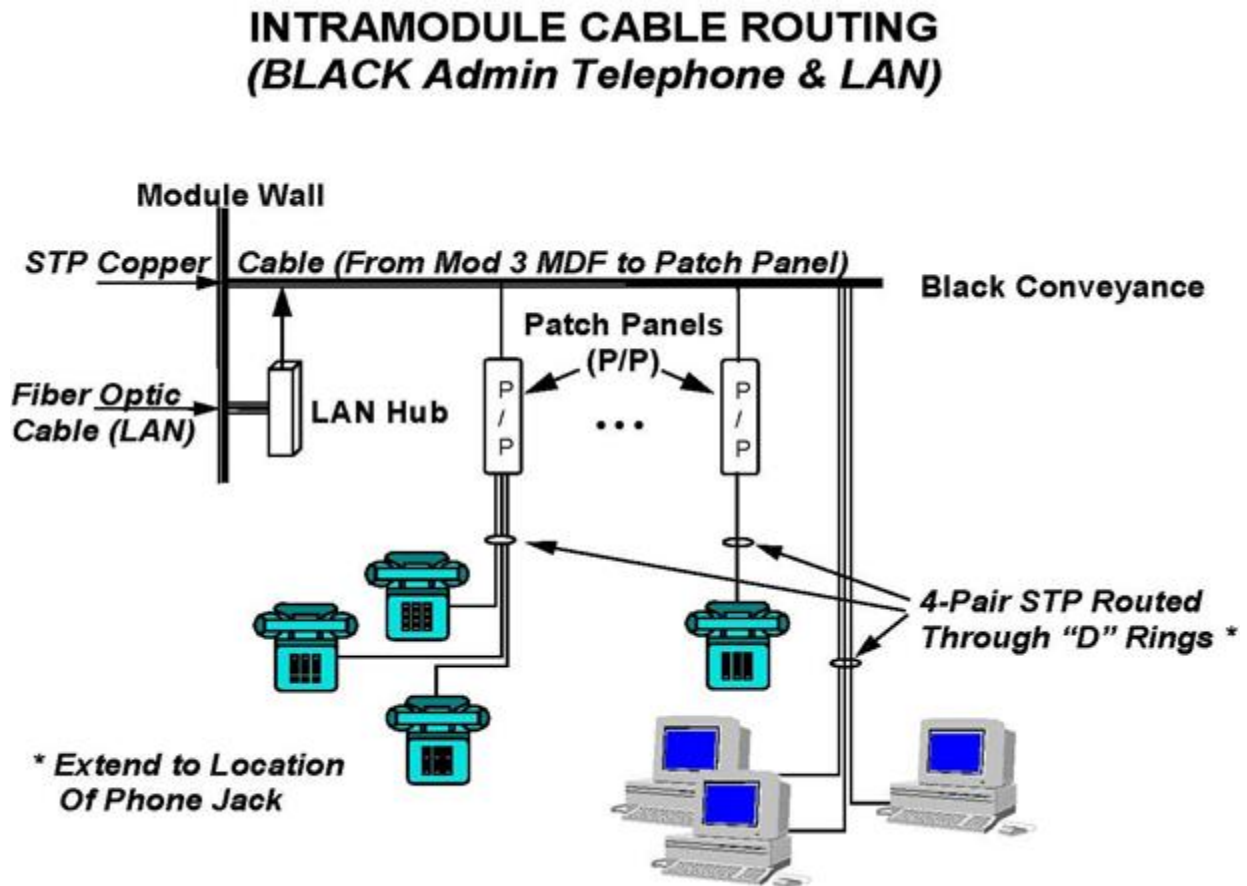

2.9.2.5. Communications Cable Distribution Between SAFB Buildings and Leaving SAFB.

2.9.2.5.1. Cable distribution between SAFB buildings shall be by means of approved conveyances within the base utilidor system and/or the manhole and duct bank system.

2.9.2.5.2. Fiber optic cables with *non-conductive* characteristics shall be used for all communications cables entering or leaving SAFB.

2.9.3. **RED/BLACK Separation.** Cables shall be installed in the RED, BLACK, and fiber optic-only cable conveyances on SAFB per AFSSI 7702

2.9.3.1. Top Secret/Special Access (TS/SA) Conveyances. All metallic or fiber optic cables carrying clear text TS/SA signals shall be installed in TS/SA conveyances (within a TS/SA controlled area). Exceptions are by written approval only. When these cables exit the TS/SA controlled area, the cables must be installed in an approved simple carrier per AFSSI 7703, *Communications Security: Protected Distribution Systems (PDS)*.

2.9.4. **Authorized Cable Types.** All communications cables (fiber optic or metallic) and other non-power cables not specifically listed for an application or as a component part of the computer systems and other equipment to which it is connected shall meet the requirements described below.

2.9.4.1. Fiber optic cable shall have non-conductive characteristics (i.e., non-conductive jackets, strengtheners, etc.) and be NFPA 70 listed (See **Table 2.1**).

2.9.4.2. Metallic cables shall be NFPA 70 listed (See **Table 2.1**). Cables designated as RED (classified clear text) will be shielded per AFSSI 7702 and shall have the capability to be grounded per MIL-STD-1542B, *Electromagnetic Compatibility and Grounding Requirements for Space System Facilities*. Metallic cables shall be grounded IAW MIL-HDBK-419A.

Table 2.1. Acceptable Cable Fire Rating Designators for SAFB.

Cable Type	NFPA 70 Article	Rating Designator
Communication	800	CMP, CMR, CMG, CM, CSA, FT1, VW1
Signal	725	CL3P, CL2P, CL3R, CL2R, CL3, CL2
Fire Alarm	760	FPLP, FPLR, FPL
TV and Radio	820	CATVP, CATVR, CATV
Optical Fiber	770	OFNP, OFNR, OFNG, OFN
IT Equipment	645	CL2, CL3, NPLF, FPL, OFN, CM, CATV
<p>NOTE: IAW the NEC, PLENUM rated cables are mandatory for all installations under floor, above ceiling or in any other plenum air space or shall be installed in non-combustible conduit in accordance with NFPA 70 as referenced in UFC 3-600-01 para 4-11.7.</p> <p>ALL cables shall be marked in accordance with NFPA 70. ALL previously installed non-rated cable will be replaced with rated cable when the equipment item is changed or relocated requiring rerouting of the cable outside the current equipment rack.</p> <p>Under NO conditions shall a cable designator or rating ending in “C” (CONDUCTIVE JACKET) or “X” (RESIDENTIAL) be approved for installation at SAFB. Non-fire rated cabling may be used in direct-bury installations only.</p>		

2.9.4.3. CAT 5 or greater shall be used when installing copper cable for administrative telephone and Local Area Network (LAN). Blue will be used for Non-secure Internet Protocol Routed Network (NIPRNet), red for Secure Internet Protocol Routed Network (SIPRNet), white for telephone, and gray for special purpose installs.

2.9.4.4. Cable Installation Standards. Telecommunication and LAN infrastructure shall be installed IAW Telecommunications Industry Association (TIA)/Electronic Industries Alliance (EIA)-568-B.1, *Commercial Building Telecommunications Cabling Standard, General Requirements*, TIA/EIA-568-B.2, *Balanced Twisted-Pair Cabling Components*, and TIA/EIA-568-C.3, *Optical Fiber Cabling Standard*.

2.9.5. Waveguides And Rigid Coaxial Cable.

2.9.5.1. Installation. Waveguide and rigid coaxial cable runs shall be made as short as possible and shall contain a minimum of couplings and bends. Bends shall be accomplished using standard manufactured fittings. Particular care shall be given to the proper alignment and fitting of waveguide sections during installation. Horizontal sections of waveguide and rigid coaxial cable shall be level and vertical sections shall be plumb.

2.9.5.2. Pressurization. Where installation for pressurization is required fittings shall be sealed and airtight. Bottled nitrogen shall be used for pressurization of waveguide systems and for rigid coaxial cables systems that have normal leak rates of less than 0.0026 Cubic Feet per Minute (CFM). Systems having higher leak rates and/or that require a continuous supply of gaseous dielectric to maintain their electrical characteristics shall be pressurized with dehydrated air. A line bleed assembly shall be installed at the end of each line to permit purging. The assembly shall consist of a 2-1/2 inch diameter pressure gauge and a bleed valve. The pressure gauge shall be installed upstream of the bleed valve.

2.9.6. General Installation Guidelines.

2.9.6.1. Routing in Cable Trays.

2.9.6.1.1. All metallic communications cables shall be installed in separate RED/BLACK cable conveyance devices.

2.9.6.1.2. Cables shall be installed parallel and in an orderly fashion to permit the maximum number to be installed in each section of tray. Where cable transitions are made, cables shall be installed without tension. Cables shall be free from sharp bends and kinks. Unsecured cables tend to slip at turns and junctions of trough and trays resulting in poor appearance, height of pileup out of proportion to the amount of cable and possible damage to conductors or cable sheath due to sharp bends. Ref: T.O. 31-10-13 Para. **3-5.1**.

2.9.6.1.3. All cables routed in the under-floor space or suspended from ceilings shall be installed in an approved conveyance. The distance from the conveyance to the raised-floor penetration shall not exceed a three-foot horizontal run.

2.9.6.1.4. Cables installed where the raised-floor height is one foot or less may be laid on the subfloor surface provided the surface is free of objects that could damage the cable. Cable trays are not required in these areas; however, RED/BLACK separation shall be maintained.

2.9.6.1.5. While installing cables the pulling tension of a fiber optic cable shall not exceed the manufacturer's rated maximum tensile loading of the cable being installed. Fiber optic cable shall not be bent beyond the rated minimum bend radius of the cable being installed. It is recommended a fiber optic service loop shall not exceed five feet on each end.

- 2.9.6.1.6. For data and communication cables at a security level of TOP SECRET and above, TPS/TSPS power cables shall not be installed in the same conveyance device, to include the same ceiling, floor, or wall penetrations. Prefabricated combination power and communications cables are not authorized at any security level.
- 2.9.6.2. Cable Termination Methods. Cables shall be terminated according to standard installation practices. The following guidelines apply:
- 2.9.6.2.1. All cables shall be terminated in connectors, terminal boards, or barrier strips. Cable conductors shall be fanned out to match the terminals to which they are attached. Spare conductors shall be cut to a length sufficient to reach any contact and laced into the same bundle with the active conductors. Spare coaxial cables shall be terminated with their characteristic impedance on one end and to a bulkhead or equivalent connector on the source electronic rack.
- 2.9.6.2.2. All cables shall be supported at the termination points to remove connector and cable strain IAW TO 31-10-13, *Air Force Communications Service (E-1 Standard) Standard Installation Practices, Cabling for Fixed Ground C-E-Equipment, Army FM-487-19*. Terminal devices shall be the kind that supports the wire at the insulation. Spare conductors in excess of the connector pins in potted connectors shall be cut back. All cable ties used to restrain wire bundles or cables shall have their excess tails cut off and all sharp edges removed.
- 2.9.6.2.3. Spare conductors that penetrate a shielded enclosure shall be grounded within the enclosure.
- 2.9.6.2.4. All standard wires that connect to equipment with screw terminals shall be terminated with an insulated terminal lug. Crimp-on terminals shall be installed with a tool approved by the terminal manufacturer.
- 2.9.6.2.5. Shields and drain wires that are not required to be connected at the equipment shall be cut off close to the cable and taped. The shrink-on ID sleeve may be positioned to insulate the shield end instead of tape, provided the sleeve completely insulates the end of the cable.
- 2.9.6.2.6. The installing agency shall install terminal boxes as close to the equipment as practical. Boxes shall accept appropriate incoming and outgoing communications and shall have the volume required by the NEC for the number of conductors enclosed. A minimum of 20 percent spare terminal board strips shall be provided in each box.
- 2.9.6.3. Tray Fill Considerations. Cable lengths shall be selected to minimize excess cable in the trays and cable wireway. The maximum cross-sectional area fill rates shall be IAW TO 31-10-13, Table 1.3.
- 2.9.6.3.1. Service loops shall not be put in cable trays or on the floor. Cable shall be coiled into service loop and attached to the side of the cable tray or support stanchion with a nylon cable tie wrap.
- 2.9.6.3.2. For runs between buildings and building modules service loops for fiber optic cable shall be no greater than five feet at each end. When installed and fanned correctly, copper should not need service loops.

2.9.6.4. Cable Splicing.

2.9.6.4.1. **Metallic Cable.** Lengths of cable shall be continuous and without splices between termination points. When required, the only cable-to-cable interconnection permitted shall be by connecting cables that have been terminated in either multi-pin or coaxial connectors. Interconnections shall be moisture resistant and continue all electrical and mechanical characteristics of the cable. In-line connectors for both multi-conductor and coaxial cables shall be covered with an appropriate insulating sleeve (i.e., heat-shrink tubing). Complete integrity of the cable shielding shall be maintained. When metallic cables are extended in this manner, the requirements defined in the following sections shall apply.

2.9.6.4.1.1. Insulation of an in-line connector shall be by installation of a section of heat-shrink tubing over the connector. The tubing manufacturer's Installation Specifications shall be used to shrink the tubing down to an even fit over the full connector run. Tubing shall be of the correct size to shrink snugly over the full length of the installation. The tube shall extend at least two inches beyond the connector at each end.

2.9.6.4.2. **Fiber Optic Cable.** Specific installation procedures for fiber cable splicing shall be fusion type. (Reference TO 31-10-34, *Joint Services Command Control Communications and Computer Systems Engineering and Installation Fiber Optic Communication Cables and Connectors*).

2.9.6.4.2.1. Vendors have varying procedures for fiber cleaving, fiber end preparation, and connector-to-fiber mating. Procedures for SAFB shall be IAW TO 31-10-34.

2.9.6.4.2.2. Installation, conveyance, and termination of fiber optic cables shall be done IAW TO 31-10-34 to protect individual fiber strands from damage and provide appropriate strain relief.

2.9.7. **Cable Marking.** Cable labels shall meet size, location, and information content as listed in TO 31-10-13, paragraph 1.13.

2.9.7.1. **Cable Labeling Requirements.** Cable labels will be placed on the cables at the time of installation, whether or not the cables have been terminated. Each cable shall be identified at the time of installation by number and letter combinations using permanently attached markers. Cables shall be marked with the cable designator at both ends, inside manholes, junction boxes, and within 12 inches of entry and exit from multi-cable transits, waveguides, wall penetrations, and enclosures. (See [Figure 2.9](#)).

2.9.7.1.1. If interduct flexible conduit is used, cable designators of cables routed through the conduit shall be marked on the outside of the interduct conduit. Cable conveyance enclosures that do not allow visual verification of cables shall have an attached tag that lists the cables contained therein. If the cable is fiber optic, the words "*Fiber Optic Cable*" shall be labeled next to the cable designator. This requirement shall be waived if the cable has been marked "*Fiber Optics*" by the manufacturer at the time the cable was built. Where the ends of the cable are not visible or accessible, the labels shall be affixed to the cables down line at the first place where access can be achieved.

- 2.9.7.1.2. The Start Equipment Reference Designator (SERD) and the End Equipment Reference Designator (EERD) shall be marked at each end of the cables on the same labels as the Cable ID number. Cable markers shall be of non-conductive material. **Figure 2.9** illustrates the required cable marking and **Figure 2.10** illustrates the marking locations.
- 2.9.7.2. Intra-Rack Equipment. Cables that do not leave a rack are not required to be marked. Marking of such cables is up to the discretion of the installer. If the installer uses a cable management number, it must be included in the CIPS package documentation.
- 2.9.7.2.1. Intra-Mod Cables. Cables that do not leave the Mod require marking, but may be marked as to be identified by the mission owner/manager of the cables.
- 2.9.7.2.2. Equipment such as stand-alone desktop computers that have cables to connect components of a system such as mouse, keyboard, or speaker need not be marked unless the cabling runs through the cable tray system. Cables that provide external connectivity (i.e. LAN cables) shall be labeled appropriately.
- 2.9.7.3. Attaching Devices. An identification label shall be attached to each cable by means of non-metallic attaching devices such as polyethylene tubing, nylon label ties, self-laminating adhesive vinyl, silicone rubber sleeving, or synthetic resin sleeving.
- 2.9.7.4. Cable Marking Tape. If existing cables are to be re-labeled and shrink tubing cannot be used, the label shall be attached using tape.
- 2.9.7.5. ID Tag Marking. Markings shall be of sufficient size and spacing to be legible and of a color that contrasts with the material on which it is marked. All markings shall be permanent. Any of the following methods may be used:
- 2.9.7.5.1. Permanent ink stamping.
 - 2.9.7.5.2. Paint stenciling.
 - 2.9.7.5.3. Typing/hand-printing (covered with a suitable protective material).
 - 2.9.7.5.4. Hot impression stamping (Kingsley machine or equivalent).
- 2.9.7.6. Buried Cables. Direct-buried cables shall be marked with the cable designator at each end.

Figure 2.9. Typical Cable Identification Tag Requirements.

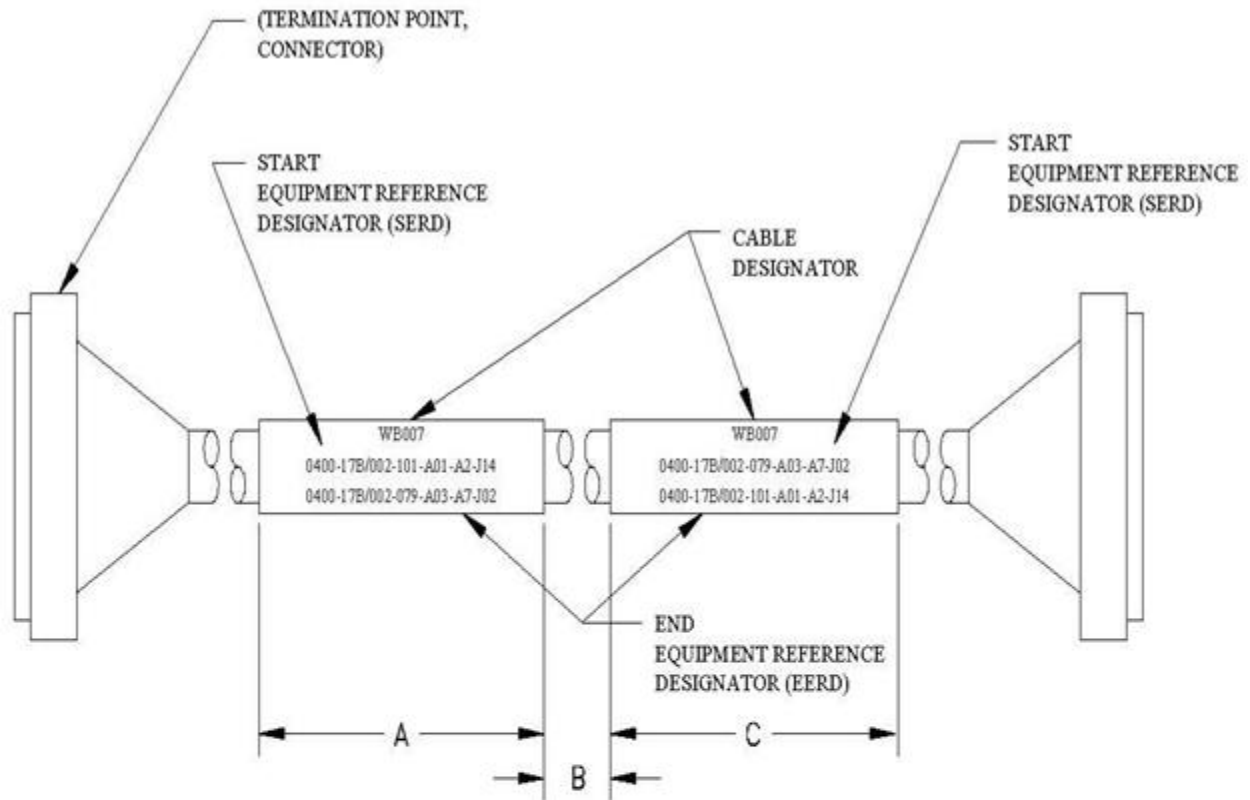

A & C – Locate label to suit installation, but not more than 12 inches from the connector.

B – When an additional cable information label is required it must be placed at both ends within 3 inches of the SERD label.

Figure 2.10. Typical Identification Tag Locations.

A= Cable Number Only. Locate label to suit installation, but not more than 12 inches from the wall.

B = Cable Number and To and From Equipment Numbers. When an additional cable information label is required it must be placed at both ends within 3 inches of the SERD and EERD labels.

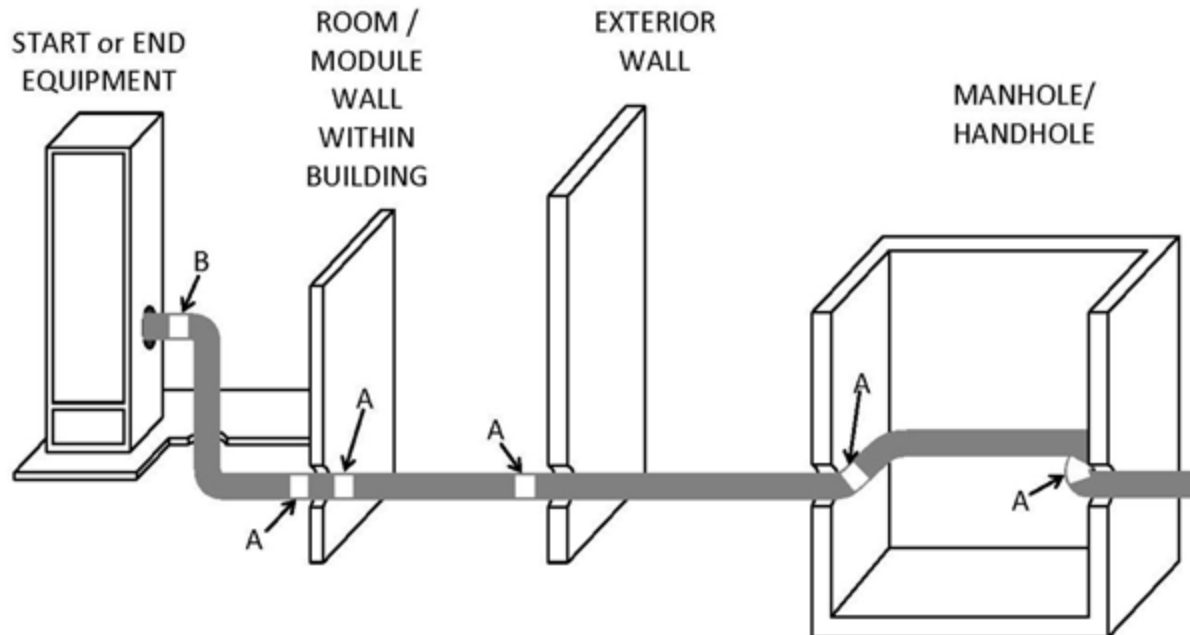

Section 2J—Cable Conveyance Devices.

2.10. General. This section defines specific conveyance device requirements. All locations shall comply with the requirements of AFSSI 7702.

2.10.1. RED and BLACK Conveyances. Separate RED and BLACK conveyances have been installed to provide raceways for fiber optic and metallic communications cables. Between buildings on SAFB, conveyances have been installed in the utilidor and in the underground manhole and duct bank system to distribute BLACK communications cables.

2.10.2. Cable Trays. Cable trays shall be installed in a pattern that provides optimum coverage of the module and minimizes cable lengths. Generally, cable trays shall be installed parallel to air-conditioning ducts to minimize obstruction to the installation of cables. RED communications cable trays shall be separated from BLACK trays as required by AFSSI 7702. The physical separation required between RED and BLACK metallic cables shall not be met by physically separating cable within the same cable tray.

2.10.2.1. Tray Types. Tray types, material, installation, and grounding shall be IAW MIL-HDBK-419A and [paragraph 2.8.5.1](#) of this publication.

2.10.2.2. Anchoring. Trays shall be rigidly anchored to the facility IAW TO 31-10-13, table 1-3, using one of the following methods:

2.10.2.2.1. When installed on the floor, trays shall be bonded to the floor with an approved adhesive or power-actuated devices such as “redheads”.

2.10.2.2.2. When the trays are suspended below the raised floor, they shall be rigidly supported to the floor pedestals using an approved unistrut/clamp system.

2.10.2.2.3. When suspended in other locations such as the cable chases, the trays shall be supported via an approved beam clamp, threaded-rod, and unistrut system.

2.10.2.3. Tray Marking. The installer shall mark Cable trays at the time of installation, with a number assigned by the 50th Communications Squadron engineering. Marking shall occur at intersections, corners, and at intervals of 10 feet or less. Trays shall be marked on the top and sides.

2.10.2.3.1. BLACK Communications Cable Trays. Cable trays that are dedicated to BLACK communications cables shall be visibly labeled “UNCLASSIFIED CABLES ONLY” at intervals not to exceed six feet. The cable tray installer shall perform labeling at the time of installation. See [Figure 2.11](#) for a typical unclassified cable tray label.

2.10.2.3.2. Fiber Optic Cable Trays. Cable trays that contain or are dedicated to fiber optic cables shall be visibly labeled “CAUTION FIBER OPTIC CABLES” at intervals not to exceed six feet. Labeling shall be performed at the time of cable tray installation by the installing agency or by the agency adding fiber optic cable(s) to existing trays. See [Figure 2.12](#) for a typical fiber optic tray label.

2.10.2.3.3. Mark all RED distribution facilities except conduit carrying a RED signal ground feeder external to the building within the inspectable space. Use a 1-inch wide strip of red tape or red paint at intervals of approximately 1-1/2 meters. This applies to copper and fiber lines. IAW AFSSI 7702, paragraph 10.49.5.4.1.

2.10.3. **Conduit.** In under-floor areas and above the ceilings, rigid metal conduit or electrical metallic tubing (EMT) may be used to provide conveyances for metallic and fiber optic communications cables. All RED/BLACK separation requirements shall be observed in the installation of these conduits. To protect cables routed above-floor, flexible metal or non-metal conduit (maximum total length of six feet) may be used to transition from floor penetrations to equipment that is not installed in racks. In the cable chases, utilidor, manhole system, and cable tray system non-metallic flexible conduit may be used to provide additional protection to cables that transition out of standard cable conveyances, provided it meets fire code. Flexible conduit shall not be installed in cable trays or in a manner that shall obstruct cable tray fill capacity.

2.10.3.1. Rigid Metal and EMT Conduit. Conduit shall be in compliance with Section H, Grounding Standards. Setscrew type couplings shall not be used. Rigid metal conduit and EMT used as cable conveyances and supported by floor stanchions shall be bonded at one end to the cable tray ground or the facility ground. Installations that are not supported by floor stanchions and that consist of more than one section shall be bonded at both ends to the facility ground.

2.10.3.1.1. Metal Conduit. Metal conduit installed above ceilings shall be installed, bonded, and grounded IAW MIL-STD-188-124B, paragraphs 5.1.1.2.4.1 and 5.1.1.2.4.2.

2.10.3.2. Flexible Metal Conduit. Flexible metal conduit shall be securely anchored within one foot of each end and at intervals not to exceed 4.5 feet, even if terminated into a fixture or equipment. Vertical installations of flexible metallic conduit inside walls may exceed six feet in length and the 4.5-foot support requirement does not apply. In no case shall conduit be used as a safety ground. All flexible conduit shall be grounded to facility ground at each end except where the conduit terminates in a box or equipment that is grounded. When used in potentially damp areas, flexible conduit shall be used with THHN, damp/dry rated ground conductors.

2.10.3.3. Conduit Marking. Conduit that is installed as a cable conveyance rather than for transition protection shall be marked with a number assigned by the 50th Communications Squadron engineering. Marking shall be accomplished at the time of initial installation by the installer. If an installing agency installs a cable in an unmarked conduit, that agency shall mark the conduit with a number obtained from engineering. Marking shall occur at each end and at intervals not to exceed 5 feet. Refer to the 50th Communications Squadron for acceptable marking methods.

2.10.3.3.1. Engineering issues four different types of conduit numbers. Three of the numbers depict the security classification levels of the cables that run through the conduits. The fourth type of number depicts the special type of cable running through the conduit. All conduits are labeled with a five digit alphanumeric number that begins with the letter "R". The second letter will have an "N" for classified (RED), a "J" for unclassified (Black), an "L" for Top Secret, or an "S" for Fiber Optic Only which includes both Red and Black fiber cables. The third letter and the following two numbers of the five-digit number are consecutive counting indicators only and have no other significance.

Section 2K—Miscellaneous Installation Requirements.

2.11. General. Miscellaneous installation standards not covered in other sections are defined.

2.11.1. **Special Design Considerations.** Modifications to areas on Schriever AFB shall comply with NFPA 70 Article 645.2.

2.11.2. **Safety.** Those agencies responsible for the installation of equipment and changes shall comply with the industrial safety accident prevention and safety and health programs defined in AFMAN 91-203, *Air Force Occupational Safety, Fire, and Health Standards* and Occupational Safety and Health Administration (OSHA) Standards, as applicable. These same agencies shall coordinate with the 50 CES Environmental Office in advance whenever dangerous materials are either shipped or hand-carried onto the site. This includes (but is not limited to) materials such as explosive charges, shots for thermite welding, and toxic or flammable gases. Additionally, 50 SFS must review and approve/disapprove all explosive items prior to being brought onto Schriever AFB. All such dangerous materials shall be stored in a designated area and in approved containers. Control of this material shall be the sole responsibility of each agency using the material.

2.11.2.1. Safety Aspects of Fiber Optics. During fiber optics installation activities, personnel shall be protected from levels of optical radiation that may be damaging to the eyes and from direct injury by fibers, particularly to the human eye or skin.

2.11.2.1.1. Optical Radiation. It is possible that the human eye can be damaged by the optical radiation from a fiber at particular power levels. If personnel must work with fibers that are emitting optical radiation, proper eye protection shall be observed. At all terminations and connections along an optical fiber length, a tag or sticker shall be placed as a warning of the presence of potentially harmful optical radiation. All terminations and connectors not in use shall be capped.

Figure 2.11. Unclassified Cable Tray Label (Black on White).

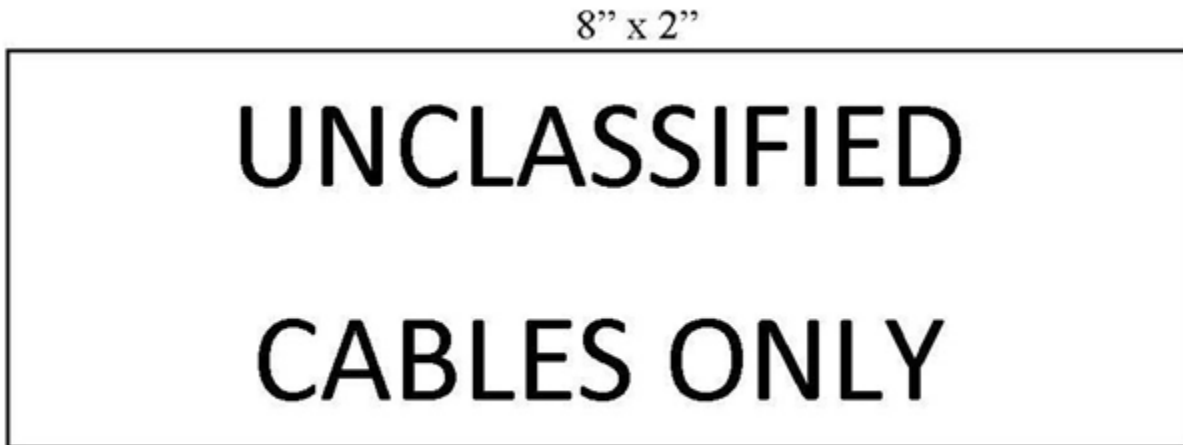
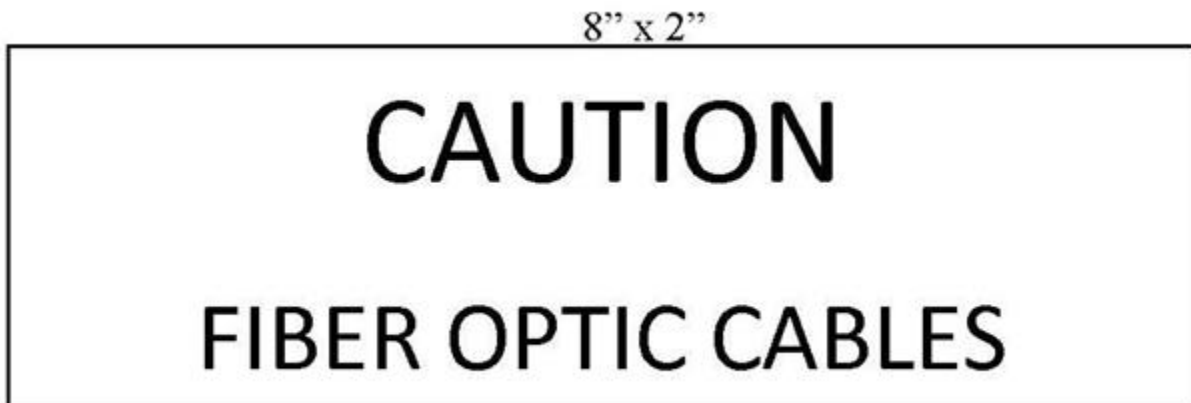

Figure 2.12. Fiber Optic Cable Tray Label (Black on Yellow).



- 2.11.2.1.2. **Direct Injury.** There is a risk of direct injury to the eye from small lengths or particles of fiber, particularly during cleaving operations. All personnel shall follow prescribed safety measures when cutting fiber optic cables. Protective eye shields shall be worn during cleaving or joining operations. Care shall also be taken to avoid glass fiber penetrating the skin. Due to the strength and small size of glass fiber, skin penetration can occur quite easily. Personnel performing termination or maintenance tasks on fiber optic cables shall clean all work areas.
- 2.11.2.2. **Welding, Cutting, Brazing, and Open Flame Soldering.** Before commencing welding, brazing, cutting, or open flame soldering operations an AF Form 592 *USAF Hot Work Permit*, shall be obtained from the SAFB Fire Department (50 CES/CEF), located in Building 717. Contractors are reminded that welding, cutting, and brazing shall be accomplished according to OSHA 1910.252, *General Requirements* or OSHA 1926.350, *Gas Welding and Cutting*, as applicable.
- 2.11.3. **Raised Floor Tile Removal and Reinstallation.** When accessing the area under a raised floor, take care not to disturb the floor level adjustment. The following guidelines and safety procedures apply to removing raised floor tiles and stringers:
- 2.11.3.1. **Safety Procedures for Raised Floor Openings.**
- 2.11.3.1.1. Remove all carpet squares on the raised floor to be opened. If carpet squares cannot be removed, the carpet squares shall be folded back and taped or clamped so the entire raised floor being opened is visible.
- 2.11.3.1.2. An individual must constantly attend the raised-floor opening when possible. If an attendant is not being used, visible barriers or blaze orange traffic cones are to be utilized. Barriers near each corner of the raised-floor opening are recommended. Use of brightly colored safety tape to connect each barrier is also recommended. Barriers must be in place when the raised-floor is opened. Carpet shall be replaced to cover the raised-floor after closing. **NOTE:** Remove only the minimum number of floor tiles required when working in an operational module where an under-floor air distribution system is required for equipment cooling
- 2.11.3.1.3. Paragraphs above do not apply to raised-floor openings during site preparation or renovation activities (large jobs). For site preparation, the entire work area shall be restricted to site preparation workers and individuals requiring entrance for official activities. Workers, surveillance, and visiting personnel shall be required to receive a safety briefing from the onsite supervisor prior to entry. This briefing shall consist of identification of all hazardous conditions and special precautions being employed. **NOTE:** The floor tiles and carpet tiles both have installation arrows on the bottom. These arrows shall point west in the installed position.
- 2.11.4. **Initial Under-floor Site Preparation (No Above-Floor Equipment).**
- 2.11.4.1. **Floor Tile and Stringer Removal.**
- 2.11.4.2. Removal of contiguous floor tiles and associated stringers is permitted where no more than one 90-degree bend is formed by an open-floor area. (Each leg of the 90 degree is one tile wide).

2.11.4.3. An open-floor area formed by the removal of contiguous floor tiles and associated stringers shall have a maximum width of one floor tile.

2.11.5. Site Preparation Involving Above-Floor Equipment .

2.11.5.1. Floor Tile and Stringer Removal.

2.11.5.1.1. Remove no more than ten contiguous floor tiles. If ten contiguous floor tiles are removed, no stringers may be removed.

2.11.5.1.2. If more than 3, but less than ten contiguous floor tiles are removed one stringer may be removed.

2.11.5.1.3. If no more than three contiguous floor tiles are removed, up to two stringers may be removed. **NOTE:** Equipment cooling requirements limit removal of floor tiles in areas where equipment is operating. Replace stringers and floor tiles according to the vendor's installation criteria.

2.11.6. Removal of Equipment/Facility Preparation.

2.11.6.1. General Requirements. Equipment, cables, and facility preparation that is no longer required for operations shall not be abandoned in place. Installations that make previous installations obsolete shall remove the unused equipment and facility preparation in its entirety. This requirement is not intended to force the removal of installations that have planned specific uses in the future, but is meant to limit unnecessary congestion in the building. Site preparation left in place for future use shall be tagged; signal conduit shall be tagged at both ends. Cables will be pulled as far back to the mod access window as possible, coiled up neatly on the floor and tie wrapped. The tag shall be placed at the end of the cable. The tag shall be marked with the following information; Reserved for future growth, date removed, expected re-use date, project name, point of contact, organization, and phone number. The door schedule shall be marked "Spare". The agency requiring the site preparation shall install the tags. The tags will be procured from the Outside Cable Plant office in Bldg. 300, Room 110.

2.11.6.2. Receptacle Removal. Removal of unused receptacles below the raised floor, including the wire and conduit is optional. If an unused receptacle below the raised floor is removed then all associated wire and conduit shall be removed. Removal of the circuit breaker is optional. If the circuit breaker is removed, a blank spacer shall be installed in the vacant space and the door schedule shall be updated IAW [paragraph 2.7.5.6.1](#) Unused openings in "J-boxes" or wireways shall be closed.

2.11.6.3. Cable Removal. When removing equipment, be sure to remove all attached signal cables from the trays and conduits under the raised floor, above the ceilings, or in the walls. **DO NOT ABANDON THESE CABLES—REMOVE THEM COMPLETELY FROM THE PREMISES**

2.11.7. **Work Site Cleanliness.** Equipment shall be protected from damage by debris of any kind, including dust, shavings, or grindings from metal, wood, concrete, or plastic. Care shall be taken not to allow such materials to enter the under-floor air plenum.

Chapter 3

INSTALLATION/MODIFICATION AUTHORIZATION REQUEST REQUIREMENTS

3.1. Scope. This chapter deals with facility preparation, cable installation, and modification, hardware (H/W) installation, and modifications for communications.

3.1.1. **General.** If a question arises as to whether or not a CIPS request is required, contact the Plans and Programs office, 567-7437, for assistance.

3.2. Cyberspace Infrastructure Planning System (CIPS) Requirement.

3.2.1. A CIPS requests is required for:

3.2.1.1. All installations or modifications of NIPR/SIPR or Voice services

3.2.1.2. All installations/modifications that require cable conveyance in support of a mission system.

3.2.1.3. All requests for new long haul communications circuits, or changes or discontinuation of such circuits.

3.3. Module Configuration Control.

3.3.1. Each organization responsible for a mission system and/or Module will be responsible for configuration management and control of their equipment.

3.3.1.1. Documentation provided to Module managers to perform QA and Configuration Control are: 1) Floor layout drawings. 2) System Connection Diagrams. 3) Cable Routing technical solution completed by 50 CS (as applicable).

3.3.2. 50 CS will be responsible for the installation and configuration management of all BOS, to include long haul communications circuits, on SAFB. 50 CS is also responsible for configuration management for all equipment, cabling, and conveyances in Bldg. 400 Mods 2A, 2B, 3/4A, 4B, 4B1A; and Bldg 700 rooms 10 and 15.

3.3.3. When the installation or modification involves a change to the facility or other work normally controlled by Base Civil Engineering, the requesting organization shall work with the Facility Manager to submit a Work Task in NexGen IT if changes to real property are required.

3.3.4. All work being performed inside a module will require coordination with the applicable Mod Manager before, during and after installation. As built drawings of equipment installed in the Mod will also be supplied within 10 business days of work completion.

3.3.5. All organizations/companies completing work in a building 400 module will follow all applicable organizational Configuration Control processes (i.e., MCB approval, etc).

Chapter 4

CABLE MANAGEMENT

4.1. Request for Cable Routing and Cable Installation Data Sheet Process.

4.1.1. A CIPS request is required for all signal/communication cable installations or rerouting of existing cables on SAFB. Request may be submitted to the organizational email address: 50SCS.SCXP.ProjectManagement@us.af.mil if a user does not have CIPS access.

4.1.1.1. The CIPS request for technical solution development will be completed by the 50 CS engineering office.

4.1.2. Identify all cable types to be installed to include: fiber, coax, copper, number of conductors/strands, conductor size, cable diameter, classification acceptable fire ratings, and any other additional comments.

4.1.3. Cable labeling is the responsibility of the installing agency or responsible project manager.

4.1.4. All cables installed must be fire rated. For a complete list of Cable Fire Rating Designators reference NFPA 70.

4.1.4.1. A list of acceptable Cable Fire Rating Designators for SAFB is listed in [Table 2.1](#).

4.1.5. Cable conveyance/conduit installations shall follow the same process as cable installation.

4.1.6. Installation scheduling and freeze deconfliction shall be coordinated with 50 CS/SCOI

4.1.7. As built drawings for all cable/conduit/conveyance installations will be provided to the CS engineering section within 10 business days of completion. Suitable format is Computer Aided Design (CAD), Visio or any other software capable of doing Shape files.

ERICKA S. FARMER-HILL, Colonel, USAF
Commander

Attachment 1**GLOSSARY OF REFERENCES AND SUPPORTING INFORMATION*****References***

DAFPD 17-2, *Cyber Warfare Operations*, 26 October 2020

AFMAN 91-203, *Air Force Occupational Safety, Fire, and Health Standards*, 10 Dec 2018

50SWI 10-217-O, *Air Force Satellite Control Network (AFSCN) Users Operations Instruction*, 4 July 2018

AFSSI 7700, *Emissions Security*, 24 Oct 2007

AFSSI 7702, *Emission Security Countermeasures Reviews*, 30 JAN 2008

AFSSI 7703, *Communications Security: Protected Distribution Systems (PDS)*, 26 Aug 2008

AFTO 31-10-13, *Air Force Communications Service (E-1 Standard) Standard Installation Practices, Cabling for Fixed Ground C-E-Equipment*, Army Fm-487-19, 1 Aug 1997

AFTO 31-10-34, *Joint Services Command Control Communications and Computer Systems Engineering and Installation Fiber Optic Communication Cables and Connectors*, 1 Oct 1998

MIL-HDBK-419A, *Grounding, Bonding and Shielding for Electronic Equipment and Facilities*, 29 Dec 1987

MIL-STD-1542B, *Electromagnetic Compatibility and Grounding Requirements for Space System Facilities*, 15 Nov 1991

MIL-STD-188-124B, *Grounding, Bonding and Shielding*, 18 Dec 2000

MIL-STD-1472G, *Human Engineering*, 11 Jan 2012

NSTISSAM TEMPEST/2-95, *RED/BLACK Installation Guidance*, 12 Dec 1995

UFC 3-600-01, *Fire Protection Engineering For Facilities* 8 Aug 2016

UFC 3-580-01, *Telecommunications Interior Infrastructure Planning*, 1 Jun 2016

American National Standards Institute (ANSI) Publications

TIA/EIA-568-B.1, *Commercial Building Telecommunications Cabling Standard, General Requirement*, 29 Mar 2018

TIA/EIA-568-B.2, *Balanced Twisted-Pair Cabling Components*, 29 Mar 2018

TIA/EIA-568-C.3, *Optical Fiber Cable Standard*, 29 Mar 2018

National Fire Protection Association (NFPA) Standards

NFPA 13, *Standard for the Installation of Sprinkler Systems*, 18 Oct 2005

NFPA 70, *National Electrical Code*, 2017

NFPA 72, *National Fire Alarm and Signaling Code*, 2016

NFPA 75, *Standard for the Fire Protection of Information Technology Equipment*, 2017 NFPA

101, *Life Safety Code*, 2018

Occupational Safety and Health Administration (OSHA) Publications

OSHA 1910.252, *General Requirements, 1 Jul 2017*

OSHA 1926.350, *Gas Welding and Cutting, 1 Jul 2017*

Prescribed Forms

None

Adopted Forms

AF Form 84, *Recommendation for Change of Publication*

AF Form 332, *Base Civil Engineer Work Request*

AF Form 592, *USAF Hot Work Permit*

Abbreviations and Acronyms

AC—Alternating Current

AF—Air Force

AFB—Air Force Base

AFSSI—Air Force Systems Security Instruction

AFSSM—Air Force Systems Security Manual

AMP—Ampere

ANSI—American National Standards Institute

APO—Air Power Off

ASTM—American Society for Testing and Material

AWG—American Wire Gauge

BCE—Base Civil Engineer

BOS—Base Operating Support

C4—Command, Control, Communications, and Computer

CAT—Category

CCS—Command and Control System

CES—Civil Engineer Squadron

CF—Compression Fittings

CFM—Cubic Feet per Minute

CFR—Code of Federal Regulations

CIBR—Communications Infrastructure Baseline Racks

CIDS—Cable Installation Data Sheet

CIPS—Cyberspace Infrastructure Planning System

CMB—Cable Management Baseline
CML—Configuration Management Lead
CMO—Cable Management Office
COB—Close of Business
CP—Conduit Penetration
CRAC—Computer Room Air Conditioner
CS—Communications Squadron
CSOC—Consolidated Space Operations Center
DC—Direct Current
DCS—Defense Communications System
DOD—Department of Defense
E&A—Engineering and Administration
ERF—50 CES Electrical Request Form
FERD—End Equipment Reference Designator
EIA—Electronic Industries Association
EGP—Equipotential Grounding Plane
EMC—Electromagnetic Compatibility
EMI—Electromagnetic Interference
EMSEC—Emissions Security
EMT—Electrical Metallic Tubing
EPO—Emergency Power Off
ERO—Emergency Refrigeration Off
Ft—Foot/Feet
H/W—Hardware
HDBK—Handbook
HEMP—High Altitude Electromagnetic Pulse
HVAC—Heating Ventilation and Air Conditioning
Hz—Hertz
IAW—*In Accordance With*
ID—*Identification*
IEEE—*Institute of Electrical and Electronics Engineers*
I/MAR—*Installation/Modification Authorization Request*

IT—*Information Technology*

Km—*Kilometer*

LAN—*Local Area Network*

LMR—*Land Mobile Radio*

M—*Meter*

MM—*Millimeter*

MCB—*Modification Control Board*

MCT—*Multi-Cable Transit*

MDIOC—*Missile Defense Integration Operations Center*

MIL—*Military*

NACSEM—*National Communications Security/Emanation Security Information Memorandum*

NEC—*National Electrical Code*

NEMA—*National Electrical Manufactures Association*

NEXT—*Near-End Cross Talk*

NFPA—*National Fire Protection Association*

NM—*Nanometer*

OD—*Outside Diameter*

OPR—*Office of Primary Responsibility*

OPS—*Operations*

OSHA—*Occupational Safety and Health Administration*

OSS—*Operations Support Squadron*

POC—*Point of Contact*

PSF—*Pounds per Square Foot*

PSIG—*Pounds per square inch gauge*

RF—*Radio Frequency*

RMS—*Root-Mean-Square*

RRR—*Reservation/Removal Request*

S/W—*Software (includes firmware)*

SAFB—*Schriever Air Force Base*

SCN—*Satellite Control Network*

SE—*Office symbol for Wing Safety Office*

SERD—*Start Equipment Reference Designator*

SIS—Systems Installation Standard

SOC—Satellite Operations Complex

STD—Standard

STL—Schriever Technical Library

SW—Space Wing

SWI—Space Wing Instruction

TAIDS—Technical Area Integration Drawings

TEMPEST—Telecommunications Electronics Material Protected from Emanating Spurious Transmissions

TO—Technical Order

TPS—Technical Power System

TSPS—Technical Support Power System (Non-Tech)

UL—Underwriters Laboratories, Inc

UPS—Uninterruptible Power System

V—Volts

XO—Neutral-Ground bond at an electric transformer or separately derived AC electrical source

Terms

SCN—All Command and Control Systems (CCS) ground equipment, communication channels, computational resources, personnel, administration and facilities for the support of satellite tracking, commanding and telemetry reception controlled by the 22 SOPS.

SAFB Configuration Baseline—Standard installation configuration, as described in SAFB I17-201, used for review of proposed installations and modifications regarding C4 systems.

Work Days—Monday through Friday, excluding holidays.

Attachment 2

REFERENCE DESIGNATOR SYSTEM

Section A2A—Cable designator.

A2.1. A cable is a bound or sheathed group of individually insulated conductors, either metallic or fiber optic identified with a cable designator. The cable designator is the unique number used to identify a cable connecting between two (and only two) equipment items. All cables shall be identified as outlined below.

A2.1.1. The characters are the Sequence Element, consisting of a two capital letters followed by four digits to uniquely designate a single cable. A seventh character shall be added, “S” to designate spare. This requirement shall also apply to all conductors in a cable when they are “fanned out” within an assembly, and shall include all spare conductors, which shall be identified by the word “spare” in place of the specific sub-assembly/connector identification. A typical Cable Designator: **WA7351**. Any changes or exceptions must be coordinated with the Outside Cable Section, fully documented, and approved by the CS MCCB.

Section A2B—Equipment Reference Designator.

A2.2. All equipment shall be given a unique Equipment Reference Designator consisting of the facility (building) number, module number, room number, and station (equipment) number, elevation number, shelf or slot, and jack number. The jack number for NIPR/SIPR/Voice will be assigned by 50SCS/SCOIN. This number shall appear, in full, on all installed equipment.

A2.2.1. The EQUIPMENT REFERENCE DESIGNATOR shall be constructed as follows.

A2.2.1.1. The building number is the four-character designator assigned to each facility as recorded on the approved site plan. Presently assigned facility codes are listed in Section D.

A2.2.1.2. The Module number is the three-character designator assigned to each module on the approved Operations building floor plans. For other facilities with no designated module numbers, these three positions shall contain “000.”

A2.2.1.3. The room number is the three-character designator assigned to each room of a facility, as shown on the approved floor plans. Where no room number is assigned within an Operations building module, or where a facility contains only one room, these three positions shall contain “001.”

A2.2.1.4. The Station (equipment) number is the three-character location designator assigned to each item of equipment in a room or module. For new installations, equipment numbers shall be obtained per [paragraph A2.2](#). The station (equipment) number **MUST** appear in all equipment reference designations.

A2.2.1.5. The Elevation number identifies the level in which the equipment is located.

A2.2.1.6. The Shelf or Slot number identifies the equipment location within the level.

A2.2.1.7. The Jack number identifies the location on the equipment that the cable plugs into and is assigned by 50SCS/SCOIN .

A2.2.1.8. A typical Equipment Reference Designator would look like: 0400-17B/ 002-101-A01-B2-J14.

Section A2C—Identification Tag Size and Placement.

A2.3. Reference AF TO 31-10-13, for identification tag sizing and placement.

Attachment 3

RACK SPACE MANAGEMENT PROCESS

Section A3A—General

A3.1. This attachment provides information for contractors and agencies planning to utilize rack space resources at SAFB. It applies to Communications Infrastructure Baseline Racks (CIBRs).

A3.1.1. This attachment defines the management process for CIBR and shall include, but not be limited to the following:

A3.1.1.1. New rack installations.

A3.1.1.2. Rack removals.

A3.1.1.3. Installation of new equipment within existing racks.

A3.1.1.4. One-for-one upgrades to existing CIBR equipment.

A3.1.1.5. Removal of equipment from existing racks.

A3.1.1.6. Communication port utilization.

A3.1.2. Rack Elevation Standard for SAFB.

A3.1.2.1. This rack elevation standard affects all new rack installations and modifications to existing racks.

A3.1.2.2. Rack levels shall be numbered sequentially, beginning with Level A1 at the top of the rack.

A3.1.2.3. Each level is 1.75 inches in height.

A3.1.2.4. Equipment is assigned a level based upon the location of its upper edge (see [Figure A4.1](#)).

A3.1.2.5. Rear of equipment racks shall be identified in the same manner except “B” shall be used in place of “A”.

A3.2. It establishes policies and procedures for ensuring the proper configuration management of CIBR space at SAFB.

Section A3B—Responsibilities

A3.3. 50 CS/SCX is responsible for control of the CIPS requirements process. They are also responsible for ensuring all participants comply with the procedures specified in this attachment. If a specific circumstance dictates a need for deviation from the set procedures, 50 CS/SCX approval must be obtained prior to implementation.

Attachment 4

SCHRIEVER AFB RACK ENCLOSURE STANDARD

A4.1. Standard Rack Description. Outside rack enclosure size: 84 inches tall, 28 inches wide, and 36 inches deep.

A4.1.1. Front and rear doors: Both doors lockable, the latch should function when the door is unlocked and the key is unavailable and be fully vented (perforated or louvered metal the full length of the doors).

A4.1.2. Front door: Face mount preferred (flush mount is acceptable)

A4.1.3. Rear door: Flush mounted.

A4.1.4. Side panels: Lockable or removable by access to the inside only. Solid, not vented.

A4.1.5. Mounting Rails: Two sets of rails, front and rear. The rails must be adjustable front to rear. The equipment mounting holes on the rails should be square. Include some equipment mounting hardware (Min. 20 clip-nuts, 20 screws). The rack must be able to support 23 inch equipment, however if the 23 inch equipment is removed, the rail angles should be able to be adjusted to support 19 inch equipment. Using adaptor ears to bridge the gap between the 23 inch rails and the 19 inch equipment is NOT acceptable. The default equipment will usually be 19 inch.

A4.1.6. Power strips: Two 20-Amp 110VAC power strips, vertically mounted in the rear inside of the enclosure. Each power strip shall have a 20-amp twist-lock plug (NEMA L5-20P).

A4.1.7. Base of enclosure: Except for the mounting of the enclosure the bottom should be open. **NOTE:** The enclosure will be bolted directly to the floor, no wheels or adjustable feet are required.

A4.1.8. Top of enclosure: Minimum of two, 2-inch punch-outs for wiring and power. One 400 CFM (or greater) fan mounted in the top of the enclosure.

A4.1.9. Grounding: One copper grounding buss, vertically mounted in the rear, inside, running approximately the height of the enclosure.

Figure A4.1. Typical Rack Elevation.

