

**BY ORDER OF THE SECRETARY
OF THE AIR FORCE**

**AIR FORCE MANUAL 11-2B-52
VOLUME 3**



12 MARCH 2019

**MINOT AIR FORCE BASE
Supplement**

17 JUNE 2026

Flying Operations

B-52 OPERATIONS PROCEDURES

COMPLIANCE WITH THIS PUBLICATION IS MANDATORY

ACCESSIBILITY: Publications and forms are available for downloading or ordering on the e-Publishing website at www.e-Publishing.af.mil.

RELEASABILITY: There are no releasability restrictions on this publication.

OPR: AFGSC/A3TO

Certified by: HQ USAF/A3T
(Maj Gen Scott F. Smith)

Supersedes: AFI11-2B-52V3, 14 June 2010

Pages: 81

(MINOTAFB)

OPR: 5OG/OGV

Certified by: 5OG/CC
(Colonel John E. Burrell)

Supersedes: AFI11-2B-52V3_MINOTAFBSUP,
1 December 2022

Pages: 81

This volume implements Air Force Policy Directive (AFPD) 11-2, *Aircraft Rules and Procedures*; AFPD 11-4, *Aviation Service*; and Air Force Instruction (AFI) 11-202 Volume 3, *General Flight Rules*. This publication applies to Regular Air Force and Air Force Reserve military and civilian personnel. This publication does not apply to the Air National Guard. Ensure all records created as a result of processes prescribed in this publication are maintained in accordance with Air Force Manual (AFMAN) 33-363, *Management of Records*, and disposed of in accordance with the Air Force Records Disposition Schedule located in the Air Force Records Information Management System. Refer recommended changes and questions about this publication to the Office of Primary Responsibility (OPR) using the AF Form 847, *Recommendation for Change of Publication*; route AF Forms 847 from the field through the appropriate functional chain of command. The authorities to waive wing/unit level requirements in this publication are identified with a Tier (“T-0, T-1, T-2, T-3”) number following the compliance statement (See [paragraph 1.3](#)). See AFI 33-360,

Publications and Forms Management, for a description of the authorities associated with the Tier numbers. Submit requests for waivers through the chain of command to the appropriate Tier waiver approval authority, or alternately, to the requestors commander for non-tiered compliance items. This AFI may be supplemented at any level, but all supplements must be routed to Air Force Global Strike Command, Standardization and Evaluations (AFGSC/A3TV) for coordination prior to certification and approval. When guidance in this manual duplicates, changes or conflicts with already published information contained in other AFGSC documents, the material in this manual takes precedence.

(MINOTAFB) Air Force Manual (AFMAN) 11-2B-52 Volume 3, B-52 Operations Procedures, is supplemented as follows: This publication establishes responsibilities, requirements, and restrictions for all 5th Bomb Wing (5 BW) flying personnel. It applies to all 5 BW personnel associated with flying operations. Refer recommended changes and questions about this publication to 5th Operations Group Standardization and Evaluation (5 OG/OGV) using the AF Form 847, Recommendation for Change of Publication. Ensure that all records created as a result of processes prescribed in this publication are maintained in accordance with (IAW) Air Force Instruction (AFI) 33-322, Records Management and Information Governance Program, and disposed of IAW the Air Force Records Information Management System (AFRIMS) Records Disposition Schedule (RDS).

SUMMARY OF CHANGES

This volume has changed substantially from the previous edition and must be reviewed in its entirety. It has been simplified and shortened, in part by eliminating detailed discussions of flying procedures and techniques that are included in B-52 techniques, tactics and procedures. Guidance has also been changed to allow greater flexibility, by eliminating unnecessary detail and lowering waiver levels, and generally to reflect an operational risk management (ORM) mindset.

(MINOTAFB) This publication has been substantially revised and must be reviewed in its entirety. Major changes include the following: guidance regarding sortie cancellation discretion, AF Form 4037's, clarification of runway sweep requirements, divert table information, operational callsigns, clarification of fuel requirements, and survival vest requirements.

Chapter 1—OVERVIEW	5
1.1. Aircrew Responsibility.	5
1.2. Deviations.	5
1.3. Waivers.	5
1.4. After Action Reports.....	5
Chapter 2—MISSION PLANNING	6
2.1. Mission Planning Requirements.	6
2.2. Roles and Responsibilities.	6
2.3. Required publications.	6

AFMAN11-2B-52V3_MINOTAFBSUP 17 JUNE 2026	3
2.4. Mission Planning Standards.....	7
Chapter 3—NORMAL OPERATING PROCEDURES	9
3.1. General.....	9
3.2. Air Refueling.	10
3.3. Low Altitude (LOWAT) Operations.	11
3.4. Night-Vision Goggles (NVG) Procedures.	13
3.5. Formation.....	13
3.6. Traffic Pattern.	16
3.7. Postflight.....	17
Chapter 4—INSTRUMENT PROCEDURES	19
4.1. Navigation.....	19
4.2. Simulated Instrument Flight.	19
4.3. Airborne Radar Directed Approach (ARDA).	19
Chapter 5—AIR EXPENDABLES EMPLOYMENT	20
5.1. General.....	20
5.2. Training Flare Drop Activity.	20
5.3. Inadvertent Release.....	20
5.4. Self-Defense Employment.....	20
5.5. Chaff.	20
Chapter 6—AIR-TO-GROUND WEAPONS EMPLOYMENT	21
6.1. References and Authorities.	21
6.2. Definitions.	21
6.3. Planning Guidance.....	22
6.4. Target Data Verification.	23
6.5. Inflight Procedures.....	23
6.6. Release Verification.....	24
6.7. Weapon Jettison.....	24
6.8. Hung Weapon Procedures.....	25
6.9. Targeting Pod (TGP) Restrictions.	25
Chapter 7—ADDITIONAL OPERATIONAL LIMITS AND RESTRICTIONS	26
7.1. New/Modified Aircraft Equipment/Weapons.....	26
7.2. Fuel Quantity Indication System Failure.	26

7.3.	Takeoffs and Critical Phases.....	26
7.4.	Unusual Attitudes and Stalls.	27
7.5.	Initial Buffet.....	27
7.6.	Fuel Minimums.....	27
7.7.	Emergency Limitations.....	27
7.8.	Inflight Simulated Emergency Procedures.	28
Table 7.1.	Simulated Emergency and Transition Limitations.....	29
Chapter 8—LOCAL OPERATING PROCEDURES		31
8.1.	General.....	31
Table 8.1.	(Added-MINOTAFB) Training Mission Pre-Takeoff Timeline.....	32
Table 8.2.	(Added-MINOTAFB) HHD Mission Pre-Takeoff Timeline.....	33
Table 8.3.	(Added-MINOTAFB) Local Radio Standards.....	35
Table 8.4.	(Added-MINOTAFB) Formation Frequencies/TACAN.	36
Table 8.5.	(Added-MINOTAFB) Off-Station Transition Restrictions.	38
Table 8.6.	(Added-MINOTAFB) Alternate Airfield Fuel Requirements.	45
Attachment 1—GLOSSARY OF REFERENCES AND SUPPORTING INFORMATION		48
Attachment 2—LOW-LEVEL OPERATIONS ON MILITARY TRAINING ROUTES		57
Attachment 3—STRANGE FIELD FAMILIARIZATION		61
Attachment 4—STRATEGIC WEAPONS FERRY MISSION REQUIREMENTS		63
Attachment 5—LOST WINGMAN PROCEDURES		66
Attachment 6—(Added-MINOTAFB) OFF-STATION TRAINING FLIGHTS AND AIR SHOWS		68
Attachment 7—(Added-MINOTAFB) TAXI-BACK LANDING AND QUICK TURN PROCEDURES		70
Attachment 8—(Added-MINOTAFB) ARDA PROCEDURES		74
Attachment 9—(Added-MINOTAFB) TAXI LANES AND OBSTRUCTION CLEARANCE		76
Attachment 10—(Added-MINOTAFB) TECHNICAL ORDERS CONTROL		78
Attachment 11—(Added-MINOTAFB) WEAPONS FLOW CHART		79
Attachment 12—(Added-MINOTAFB) COLD WEATHER OPERATIONS ANNEX		80

Chapter 1

OVERVIEW

1.1. Aircrew Responsibility. This regulation prescribes procedures for operating the B-52 aircraft under most circumstances. It should be followed in conjunction with AFI 11-202, Volume 3. Never compromise sound judgement, safety or common sense to obey the processes and procedures found in this manual. Other operating procedures not specifically addressed herein, may be used when they enhance safe, effective mission accomplishment.

1.2. Deviations. Deviations from these procedures require specific approval by the MAJCOM/A3 or tiered waiver authority unless an urgent requirement or an aircraft emergency dictates otherwise, in which case the pilot in command will take the appropriate action to accomplish the mission and safely recover the aircraft. (T-3).

1.3. Waivers. Forward T-0, T-1 and T-2 waiver requests to the AFGSC, Director of Operations (AFGSC/A3) or AFRC/A3D for approval. Waivers are valid for one year from the approval date. In accordance with (IAW) AFI 33-360, T-3 waiver authority may be delegated to group or squadron commanders. Information copies will be provided IAW AFRC procedures.

1.4. After Action Reports. Squadron commanders are responsible for submitting After Action Reports to Air Force Global Strike Command, Lessons Learned (AFGSC/A9L) within 45 days of returning from any deployment. (T-2).

Chapter 2

MISSION PLANNING

2.1. Mission Planning Requirements. All missions must be planned in sufficient detail to ensure safe, effective employment and compliance. Flying crews must fully review all aspects of the mission to ensure they can meet objectives and make sound decisions balancing mission accomplishment and safety. (T-3). Mission planning takes priority over other non-flying duties.

2.1.1. For self-planned sorties, (i.e. mission plan/fly) all crewmembers must be present for mission planning unless excused by the Squadron Operations Officer. (T-3). Crews must have access to mission planning areas as in [paragraph 2.1.2](#) (T-3). Provide sufficient time to plan and prepare for the sortie.

2.1.2. All crewmembers will attend the Pre-Takeoff Brief (PTOB). Flying crews will be given adequate time to review all information pertinent to the mission, to include any time and facilities needed to adjust, print or complete any off-the-shelf products or paperwork. Any substitutions after the PTOB and mission planning day, require approval by the Squadron Operations Officer. (T-3).

2.1.3. Target Study. Target study will be led by a qualified single or multi-ship mission lead, and accomplished as an integral crew or formation for all live and inert weapons activity. (T-3). Brief targets, ingress and egress, threats and tactics, contingencies, and current information on the airspace, range(s), and areas of responsibility along with the associated procedures, SPINS, etc. Reference and brief applicable items from AFI 11-214, *Air Operations Rules and Procedures* and B- 52 TTPs.

2.2. Roles and Responsibilities. The mission lead and aircraft commander (AC) should validate the tactical plan, weapons employment and crew preparation. A qualified mission lead will be designated for every sortie with actual weapons. (T-3). Sorties with simulated weapons should include a mission lead; if none is available, the AC or senior instructor fills the role. The mission lead is responsible for successful tactical employment, to include planning and debrief. The AC is responsible for mission data, crewmember qualifications and currencies.

2.3. Required publications.

2.3.1. Technical Orders. Each crewmember will have and refer to appropriate flight manual checklists during ground and flight operations to ensure accomplishment of prescribed actions. (T-2). Crews will have access in flight to complete aircraft/weapons/systems technical orders applicable to the mission. (T-2). Flight surgeons and flying crew chiefs not issued flight manuals are responsible for maintaining adequate knowledge of emergency procedures. (T-3).

2.3.2. Required Directives. Carry AFI 11-202 Vol 3 (and any applicable supplements), this manual and local flying directives on electronic flight bags (EFB) in flight. Units will set a baseline of publications for the EFB. (T-3).

2.3.3. Units will develop local aircrew aids (e.g. in-flight guide), to include:

2.3.3.1. Weight and balance data for calculating local aircraft configurations. (T-3).

2.3.3.2. Local radio channelization and airfield diagrams. (T-3).

2.3.3.3. Impoundment and radio-out procedures. (T-3).

2.3.3.4. Recovery procedures with weapons, local jettison, bailout areas and hot brake areas and procedures. (T-3).

2.3.3.5. Divert, alternate and emergency airfield/runway data, coordinates, approximate course and distance, estimated time enroute (ETE), altitude, and fuel required. (T-3).

2.4. Mission Planning Standards.

2.4.1. Takeoff computations. A minimum of 1,000 feet overrun must be available in addition to the minimum runway required (MRR). (T-3). When 1,000 feet of overrun is not available, reserve a portion of the runway to satisfy the minimum overrun requirements. Runway available for takeoff planning must be actual runway length minus any portion of the runway used to satisfy overrun requirements at the liftoff end of the runway. (T-3).

2.4.2. Normal peacetime performance criteria and the provisions of [paragraph 2.4.1](#) apply to conventional operations and must be observed in the interest of safety and economy. (T-3). At no time will launch be directed when computed takeoff distance exceeds 95 percent of runway available. (T-2).

2.4.3. High Altitude Charts. Each sortie will have at least one printed chart covering 50 nautical miles (NM) on either side of the planned flight in an appropriate scale. (T-3). Electronic charts may be used outside of that area and for divert coverage. Use chart symbology IAW Air Force Pamphlet (AFPAM) 11-216, *Air Navigation*, and Air Force Global Strike Command Instruction (AFGSCI) 13-520-S, Volume 2, *Bomber Nuclear Mission Preparation*, as a guide.

2.4.4. Low Altitude Charts. On low altitude training flights, one pilot, one Weapon Systems Officer (WSO) and the Electronic Warfare Officer (EWO) will carry a chart. (T-3). The chart will be of such scale and quality that depictions of terrain features, hazards, noise sensitive areas, and chart annotations allow individual navigation and safe mission accomplishment. (T-3).

2.4.4.1. Annotate noise sensitive areas, location and dimensions of class B/C/D airspace, civil and military airfields, and other potential high-density traffic areas (e.g., parachute activity areas and ultra-light, hang glider, glider sites, etc.) within 5 nautical miles (NM) of any planned VFR route or airspace boundary. (T-3).

2.4.4.2. Applicable airfield approach control frequencies in the vicinity of class B, C, and D airspace will be annotated and briefed on all such flights. (T-3). In addition, annotate and brief the intersection of crossing Instrument Flight Rules (IFR) Military Training Routes or Visual Flight Rules (VFR) Military Training Routes (if applicable) and any other possible areas of conflict. Review pilot's and WSO's charts for compatibility and accuracy. (T-3).

2.4.4.3. When manually creating low-level charts, update charts from the Chart Update Manual (CHUM) and annotate all noise sensitive areas along the route of flight. If using up-to-date flight planning software, ensure current Digital Aeronautical Flight Information File (DAFIF) and CHUM. (T-3).

2.4.5. Fuel Conservation. Unit leadership and aircrew will manage aviation fuel as a limited commodity. (T-3). Fuel efficiency will be considered throughout mission planning and execution. Unit leadership and aircrew will design flight plans and routing for optimal fuel use. (T-3).

2.4.6. Flight Plans. The AC's signature on the DD Form 1801, *International Flight Plan*, or submission of an electronic flight plan indicates all the items in the briefing guides were briefed or accomplished. Units filing electronically must designate alternative procedures in their local AFMAN 11-2B-52 Vol 3, **Chapter 8**, for documenting briefing requirements. (T-3).

Chapter 3

NORMAL OPERATING PROCEDURES

3.1. General.

3.1.1. Restrictions in this and subsequent chapters do not apply to weapons system trainer (WST) or aviation training device (ATD) employment; however, crews should limit non-approved maneuvers to specific learning objectives.

3.1.2. Alert crews/sorties that remain within UHF contact of local command post are exempt from Emergency Action Message HF monitoring requirements.

3.1.3. Augmented aircrew for long duration sorties will include at least three pilots and three WSOs, with at least one dual-seat qualified pilot. (T-2).

3.1.4. Basic Area Navigation (BRNAV) procedures and information.

3.1.4.1. BRNAV Airspace. Airspace where BRNAV is applied is considered special qualification airspace. Both the operator and the specific aircraft type must be approved for operations in these areas. BRNAV navigation accuracy criteria is RNP-5. (T-0). The B-52 complies with RNP-5 accuracy, integrity, and continuity and is approved for BRNAV operations requiring RNP-5 or higher criteria. Aircrew must update position as required to maintain actual centerline within +/- 5 NM of Air Traffic Control (ATC) cleared route. (T-0).

3.1.4.1.1. Minimum equipment to operate in BRNAV airspace is one INU capable of updates from Doppler and/or Radar inputs (i.e., not tied to aircraft GPS). Flights entering BRNAV airspace after long over water flight must be especially aware of BRNAV tolerances and update accordingly. Note: The B-52 GPS receiver is not certified for BRNAV operations. (T-0).

3.1.4.1.2. Minimum aircrew for BRNAV operations is a pilot team and a WSO in the Radar Navigator (RN) seat of the offense compartment.

3.1.4.1.3. Aircraft must turn short of filed points to remain within +/- 5 NM of ATC cleared route. (T-0). Aircrew should utilize the "Turn Short" feature when preparing mission data cartridges and during inflight operations.

3.1.4.1.4. Aircraft unable to maintain BRNAV tolerances must advise ATC immediately and take appropriate coordinated action. (T-0).

3.1.4.1.5. Document (in the aircraft forms) malfunctions or failures of BRNAV required equipment, including the failure of any equipment to meet BRNAV tolerances. (T-1).

3.2. Air Refueling. Air-to-air refueling operations are authorized on an IFR flight plan and along published or special tracks and anchors. In addition, under certain circumstances, enroute refueling may be conducted between aircraft comprising a formation. During these operations, it is the primary responsibility of the tanker aircrew to remain within the protected lateral, longitudinal, and vertical airspace. For the dimensions of protected airspace and other conditions/procedures affecting air-refueling operations, refer to Federal Aviation Administration Handbook (FAAH) JO 7610.4U, *Special Operations*. Military Assumes Responsibility for Separation of Aircraft (MARSA, US only).

3.2.1. MARSA between the tanker(s) and the receiver(s) begins when the lead tanker advises Air Route Traffic Control Center (ARTCC) they accept MARSA.

3.2.2. After MARSA has been declared, controller assigned course or altitude changes prior to rendezvous completion will automatically void MARSA. Once rendezvous is completed, headings and altitude assignments may be made with tanker concurrence and MARSA can remain in effect.

3.2.2.1. After rendezvous, the receiver(s) will remain within 3 miles of the tanker(s) until MARSA is terminated. (T-0).

3.2.3. Air Refueling Limitations and Restrictions:

3.2.3.1. Training in air refueling procedures, excluding rendezvous, is prohibited when the receiver aircraft is loaded with nuclear weapons. (T-0).

3.2.3.2. Coordinate emission control (EMCON) 2/3/4 procedures before flight. (T-2). Do not attempt EMCON 3/4 rendezvous unless at least 1,000 feet vertical separation is assured between tanker and receiver (i.e., the receiver is 1,000 feet or more below the base altitude and the tanker is at or above it). (T-2). Do not close within 1,000 feet vertically of the tanker unless reliable radio communications are established except for EMCON 3/4 procedures, critical fuel shortage, or as directed in tasking orders/SPINS/etc. (T-2).

3.2.3.3. Do not accomplish air refueling during training missions when any of the conditions below exist. (T-2). For operational missions, the decision to attempt refueling will be based on any applicable guidance in tasking orders/SPINS/etc. and ORM. (T-2).

3.2.3.3.1. When encountering turbulence which, in the opinion of the pilot or boom operator, denies a safe margin of control of either aircraft or boom. (T-2).

3.2.3.3.2. When two or more engines are shut down or when any engine has been shut down due to fire or fire indication. (T-2).

3.2.3.3.3. When the tanker has less than all engines operating. (T-2).

3.2.3.3.4. When any flight control problems are suspected or encountered which, in the opinion of the receiver pilot, would deny a safe margin of control. (T-2).

3.2.3.3.5. When tanker aircraft is unable to retract landing gear. (T-2).

3.2.3.3.6. When the aircraft gross weight is less than 230,000 pounds or more than the maximum limits specified in the appropriate flight manual. (T-2).

3.2.3.4. Do not conduct air refueling after known losses of tanker disconnect capability (including tanker manual operation without tanker disconnect capability or manual boom latching) except as authorized below. When refueling under these conditions, limit contact time and number of contacts to that necessary to complete mission requirements. (T-2).

3.2.3.4.1. During an emergency fuel situation. (T-2).

3.2.3.4.2. During the following missions: operational nuclear or conventional, operational readiness inspection (ORI), higher headquarters directed (HHD), emergency evacuation, deployment, and redeployment. (T-2).

3.2.4. Reverse air refueling and manual boom latching training must be under instructor pilot (IP) supervision. Brief procedures used between receiver pilots and boom operators during mission planning. Inflight coordination between receiver pilot and boom operator must include briefing items required by applicable air refueling technical orders. Both tanker and receiver air refueling system must be fully operable. (T-2).

3.2.5. Do not accomplish breakaway training from the contact position unless:

3.2.5.1. The receiver signal system is in normal. (T-2).

3.2.5.2. The receiver and tanker have assured normal disconnect capability prior to initiating maneuver. (T-2).

3.2.5.3. For breakaway training, the tanker pilot and boom operator and the receiver pilot will coordinate the maneuver prior to inflight accomplishment. (T-2). Inflight coordination must include when the maneuver will occur and who will give the command of execution. (T-2).

3.2.6. For boom envelope demonstrations, the receiver pilot and the boom operator will confirm normal disconnect capability. (T-3). Inflight coordination must include the receiver pilot informing the boom operator when commencing the demonstration, the limit demonstrated, and when terminating the demonstration. (T-3).

3.3. Low Altitude (LOWAT) Operations. The low altitude environment is defined as 5,000 feet AGL/ASL and below. Departure, transition, or short periods cruising between 2,000 and 5,000 feet AGL/ASL are not considered low altitude and do not require LOWAT currency. Conduct LOWAT in military designated employment areas as defined in [Attachment 2](#). (T-2). Note: [Attachment 3](#) contains additional guidance specifically for flying defined low-level routes.

3.3.1. Restrictions.

3.3.1.1. Crews will not fly lower than 1,000 feet AGL/ASL. (T-2). Set safe clearance altitudes (SCAs) no lower than 1,000 feet (2,000 feet in mountainous terrain) above the highest terrain/obstacle within 4 NM of the planned route. (T-2). In employment areas, establish (a) sector altitude(s) ensuring 1,000/2,000 feet clearance above the highest terrain/obstacles within 4 NM of the sector. (T-2).

3.3.1.1.1. If crews are able to visually acquire and avoid obstacles, they may fly at 1,000/2,000 feet above the highest terrain within 4 NM. If the obstacle(s) are not spotted by 4 NM, crews will climb to 1,000/2,000 feet above the obstacle(s). (T-2).

- 3.3.1.1.2. Exception: Qualified aircrew may conduct low altitude training at TA altitudes consistent with unit requirements and IAW guidance in this manual and other current directives.
- 3.3.1.2. Low altitude weight restriction is 230,000 to 420,000 pounds. (T-3).
- 3.3.1.3. Aircrews will not use the autopilot non-steering modes other than second station for low-altitude operations. (T-3).
- 3.3.1.4. Bank angles during low-level or operations below 1,000 feet AGL/ASL are limited to 30 degrees maximum. (T-2). Use steep turn guidance as applicable for higher altitudes. (T-2).
- 3.3.1.5. Do not descend below 5,000 AGL when bird status is moderate or higher without operations group commander approval. (T-3). Determine bird status by best available means, to include Bird Avoidance Model (BAM) or other predictive data combined with crew observation if actual bird reporting is not available in the area. (T-3).
- 3.3.2. Weather restrictions.
- 3.3.2.1. Icing. Do not conduct low altitude flights in areas of forecast severe icing conditions or areas of reported moderate or severe icing conditions. (T-3). If moderate or severe icing is encountered, abort the mission employment area. (T-3).
- 3.3.2.2. Turbulence. Do not conduct low altitude flight in areas of forecast severe turbulence, forecast moderate or severe turbulence in mountain wave effect, or moderate or severe turbulence reported by military aircraft. (T-2).
- 3.3.2.3. Wind Restrictions. B-52 flight at SCA is prohibited in mountainous areas when winds at or below MSA/IFR altitude are 40 knots or greater. (T-3).
- 3.3.3. Equipment Restrictions. If equipment problems impair the crew's ability to clear terrain do not attempt low-level flight. (T-2).
- 3.3.3.1. Flight Controls. Abort low-level if any flight control system malfunction denies the pilot a safe margin of control over the aircraft. (T-2).
- 3.3.3.2. Mapping Radar Failure (Scope Blank or Inadequate for Navigation). Do not fly low-level during IMC or night with mapping radar failure. (T-2). Aircraft without mapping radar may descend to the safe clearance altitude in day visual conditions only.
- 3.3.3.3. Offensive Avionics System (OAS) Processors. Do not fly low-level with less than one processor during IMC or night. (T-3). Crews may penetrate to low-level with less than one processor in day VMC.
- 3.3.3.4. Multi-Function Displays (MFDs). Do not fly low-level unless there is at least one operable MFD at the RN station and one at the navigator's station. (T-3).
- 3.3.3.5. Attitude Heading Reference System (AHRS). Do not fly low-level with a malfunctioning AHRS. (T-3). Exception: The AHRS does not need to be fully operational if one Inertial Navigation Unit (INU) is providing accurate heading and there is accurate MD-1 gyro stabilization for the pilot's attitude director indicator (ADI) (this exception applies only for day, VMC low altitude training). (T-3).

3.3.3.6. Radar Altimeter. Safe clearance altitude flight without a properly operating radar altimeter is prohibited. (T-2).

3.3.3.7. Do not practice radar silent operations in IMC or at night. (T-3).

3.4. Night-Vision Goggles (NVG) Procedures. NVGs enhance the ability to fly low-level, and may be used for a variety of tactical reasons. Crews may fly at SCA using NVGs to enhance situational awareness. Do not use NVGs for air refueling (within 3 NM of the tanker) or pattern operations. (T-3).

3.4.1. The AC will ensure sufficient operable sets are aboard the aircraft. (T-3). Each crewmember whose duties require using NVGs will be current and qualified with the NVG, unless accompanied by a current and qualified instructor. (T-3).

3.4.2. If any doubt exists concerning terrain clearance or visibility during low-level, immediately climb to a MSA/IFR. (T-3).

3.5. Formation. B-52s may employ as a formation in any phase of flight except when accomplishing instrument approaches. When in formation, aircraft/crews should operate as a unit; flight lead is responsible for safe conduct of the formation. See Air Force Tactics, Techniques and Procedures (AFTTP) 3-3.B-52 for guidance on formation flight.

3.5.1. Definitions:

3.5.1.1. Formation Flight. Formation flight by FAA definition is more than one aircraft which, by prior arrangement between the aircrews, operate as a single aircraft with regard to navigation and position reporting. Separation between aircraft within the formation is the responsibility of the flight leader and the crewmembers of other aircraft in the flight. This includes transitional periods when aircraft within the formation are maneuvering to attain separation from each other to effect individual control and during join-up and breakaway. For authorized B-52 formations, refer to AFTTP 3-3.B52.

3.5.1.2. Standard Formation. One in which each wingman maintains a proximity of no more than 1 mile laterally/longitudinally and within 100 feet vertically from the flight lead.

3.5.1.3. Nonstandard Formation. One operating under any of the following conditions (B-52s typically fly this type formation). The formation lead shall notify ATC upon initial contact that nonstandard formation operations are being conducted and, if required, advise ATC of the separation and spacing being employed (JO 7610.4U): (T-0).

3.5.1.3.1. When the flight leader has requested and ATC has approved other than standard formation dimensions.

3.5.1.3.2. When operating within an authorized altitude reservation (ALTRV) or under the provisions of a letter of agreement.

3.5.1.3.3. When operating in airspace specifically designed for special activity.

3.5.1.4. Formation Departure. A formation departure is the departure of multiple aircraft at intervals of 1 minute or less.

3.5.1.5. Enroute Formation. An enroute formation is two or more aircraft with the same intended route of flight, maintaining position by visual and/or electronic means. Formation flight requirements of [paragraph 3.5.3](#) apply. Should separation between the flight lead and any other aircraft in the formation exceed ATC separation limitations or vary significantly from that reported to ATC for the nonstandard formation, coordinate with ATC to obtain approval for greater separation or to suspend or cancel formation clearance. (T-0).

3.5.2. Responsibilities.

3.5.2.1. Flight Lead. Only ACs who are certified to be flight lead IAW AFMAN 11-2B-52, Volume 1, *B-52 Aircrew Training*, may be flight lead, unless under IP supervision. (T-2). The IP may supervise an uncertified AC from a wingman position. The flight lead may temporarily delegate flight lead duties for training or tactical considerations (i.e., equipment malfunctions).

3.5.2.1.1. Flight lead is responsible for safe and effective formation flight. (T-3).

3.5.2.1.2. Wingmen will execute lead's plan and adhere to briefed standards. (T-3). Wingmen will notify flight lead of any limiting conditions that may prevent them from executing the planned profile or limit speed, altitude, maneuvering, communications, etc. (T-3).

3.5.2.2. Mission Lead. The designated multi-ship mission lead is responsible for planning and execution of tactical employment of the formation, and will lead a formation debrief for the tactical portions of the mission. (T-3). The mission lead should brief tactical employment in conjunction with the formation briefing.

3.5.2.3. Formation Briefing. The flight lead will conduct a briefing for all crewmembers in the formation covering the planned activities, procedures, techniques, specific EMCON procedures and division of formation responsibilities. (T-3). If lead changes are planned, each flight lead should brief their portion of the mission. The flight lead must ensure all crewmembers in the formation thoroughly understand their responsibilities and will identify a deputy flight lead (if available). (T-3). Resolve any questions during the briefing. If aircraft depart from separate bases and rendezvous for formation activity, the flight lead will conduct a telephone briefing. (T-3).

3.5.3. Call Signs. To preclude confusion by ATC, if aircraft positions within a flight are changed, do not change the flight call sign or IFF squawk. (T-3).

3.5.4. EMCON. Practice EMCON to the maximum extent possible during peacetime in preparation for combat operations. (T-3).

3.5.5. Formation Takeoff. Takeoff interval is no less than 30 seconds for conventional and nuclear operations. (T-2). For receiver/tanker refueling formation departures, the receivers usually roll first, followed by the tankers in that element. Takeoff intervals or sequence may be varied as necessary depending on aircraft acceleration and performance, training requirements, weather, airfield conditions, and mission requirements.

3.5.5.1. Due to the high risk and time critical nature of take-off and initial phases of departure, flight lead will ensure each aircraft understands its responsibility in an aborted takeoff or in an emergency/malfunction immediately after takeoff. (T-3). Preview actions to be taken by each aircraft and intraflight communication/coordination. Brief procedures for loss of visual/radar contact during climbout. Flight leads should follow the standards in AFTTP 3-3.B-52 and brief any deviations.

3.5.5.2. Do not conduct Quick Taxi/Emergency War Order departure exercises (defined in AFMAN 11-2B-52 Vol 1) with nuclear weapons loaded aboard the aircraft or with aircraft gross weight over 450,000 pounds. (T-2). Do not conduct these exercises unless prior coordination has been made with all involved aircraft, local ATC and the involved ARTCC.

3.5.5.3. Quick Taxi/Emergency War Order Departure Taxi Procedures. Units will establish taxi plans from the normal parking area to each runway. (T-2). Flight lead will confirm takeoff data computations, accomplish guard receiver check, and copy ARTCC clearance in the chocks. (T-2). If takeoff clearance is canceled after the aircraft are rolling, aircraft short of the runway will not cross the hold-short line. (T-2). Following aircraft will set or adjust power as necessary to maintain proper spacing and a safe speed during taxi and alignment for takeoff roll.

3.5.6. Enroute Formation:

3.5.6.1. AFTTP 3-3.B-52 describes authorized enroute formation positions. If ATC does not approve block altitudes, formations may fly at a single altitude with suitable lateral spacing; however, flight leads should consider the additional risk and consider requesting separate altitudes instead of extended co-altitude flight.

3.5.6.2. Mid-mission join-ups should begin with intra-flight coordination on a briefed frequency. Flight leads must obtain approval by ATC prior to flying in formation. (T-0).

3.5.6.3. Issuance of separate clearance by ATC constitutes termination of formation flight for the cleared aircraft.

3.5.7. Battle Damage Checks. Flight leads should direct a battle damage check after actual weapon deliveries and/or prior to return to base. Do not perform visual checks in night or IMC, and fly no closer than route formation. (T-3).

3.5.8. Dissimilar Formations (B-52 and other aircraft). Aircrew will apply normal formation procedures during dissimilar formation as applicable while considering aircraft performance differences. (T-3). The flight/mission Lead will brief flight members on flight responsibilities, proper formation position (to ensure adequate wingtip clearance), and aircraft-unique requirements for each phase of flight. (T-3). The involved operations group commanders will approve planned dissimilar formations. (T-3). Unplanned formations should be limited to emergencies or urgent mission requirements.

3.5.8.1. Chase Operations. Prior to each planned chase sortie, the lead and chase crews will brief the mission profile, restrictions, and responsibilities. (T-3). Both aircraft must maintain radio contact throughout the operation. (T-3).

3.5.8.1.1. It is unsafe to fly in close vertical proximity to another aircraft due to the interrelated aerodynamic effects. Never fly directly over or under another aircraft. (T-3). The chase position is defined as:

3.5.8.1.1.1. Wings level position - at least 150 feet between wing tips or;

3.5.8.1.1.2. Stern position - approximately 1/4 mile behind and 100 feet below lead.

3.5.8.1.2. The normal chase position is on the right wing of lead.

3.5.8.1.3. The lead aircraft must inform the chase aircraft and receive acknowledgment prior to turns, climbs/descents, airspeed changes, or configuration changes. (T-3).

3.5.8.2. Lost Wingman Procedures. Formations will use the procedures in **Attachment 5** if separation cannot be assured. (T-3). Flight leads may modify these procedures if desired by prior coordination within the flight.

3.5.9. Low-level Formation. Weather, tactical considerations and mission objectives will dictate the degree and type of electronic emission and the extent of radio communications. When conducting low altitude training (LOWAT), formations may fly fighting wing/wedge or trail formation under day/VMC conditions only. (T-3). Reference **Attachment 2** for formation guidance specific to military training routes (MTRs).

3.5.10. Descent. The Flight Lead will brief descent procedures, tactics and airspeeds in the formation brief to ensure deconfliction. (T-3). The Flight Lead will inform all aircraft in the formation of any significant low-level weather prior to descent into the route. (T-3). If the formation will transition from high altitude visual conditions to low-level instrument conditions, all aircraft will ensure a means exists to ensure safe aircraft separation prior to descending. (T-3).

3.5.11. Separation of Aircraft. If altitude stack is not available or not suitable for employment, the Flight Lead will specifically brief deconfliction procedures (timing, “be-no” lines, etc.). (T-3). The Flight Lead will brief planned abort altitudes for the route/area, to include lost wingman contingencies. (T-3).

3.6. Traffic Pattern.

3.6.1. Use the following procedures for all landings.

3.6.1.1. To safely land a large jet aircraft, all landings (IFR and VFR) should look the same. Fly a stabilized approach with a 2.5 to 3.0 degree glidepath, which is compatible with standard ILS/Visual Approach Slope Indicator (VASI). Use a visual aim point of 1,000 feet down the runway corresponding with the fixed distance markers on a precision runway. (T-3).

3.6.1.2. Plan to land within the first 3,000 feet of the landing runway beginning at the threshold. (T-2).

3.6.1.3. Plan normal landings (IFR and VFR) to touch down on centerline within the touchdown zone (TDZ) at a point not less than 1,000 feet beyond the threshold. (T-3). For all landings, use a runway of sufficient width and length to permit a safe, full stop landing without the drag chute. (T-3). The desired TDZ is 1,200 to 2,500 feet beyond the threshold. Make the actual touchdown at a point and speed that will permit a safe, full stop landing within the remaining runway. (T-3). Initiate a go-around if this is not possible. Brief procedures to use in the event of an unplanned go-around before landing. (T-3).

3.6.2. Touch-and-go landings are authorized only under the following conditions:

3.6.2.1. Use a runway of sufficient width and length to permit a safe, normal full stop landing without the drag chute. (T-3). Make the actual touchdown in the designated TDZ of the runway at a point and speed which would enable a safe full stop landing on the remaining runway. Initiate a go-around if this is not possible. (T-3).

3.6.2.2. The Runway Condition Reading (RCR) must be 9 or higher for touch-and-go landings. (T-2).

3.6.2.3. Non-IP ACs are limited to a maximum of 4 degrees crosswind crab. (T-3).

3.6.2.4. Non-IP ACs require a minimum 1,000 feet ceiling and 3 miles visibility. (T-3).

3.6.3. IPs or ACs will brief, either inflight or during mission planning, the following items prior to accomplishing touch-and-go landings. The waiver authority to waive any of the briefing topics below is the Squadron Commander.

3.6.3.1. Flight manual procedures.

3.6.3.2. The importance of smooth power application and stabilizing power before advancing throttles. (T-3).

3.6.3.3. Go/No-go considerations and decision points while on the runway. (T-3).

3.6.3.4. Emergency jettison of drag chute. (T-3).

3.6.3.5. Proper use of airbrakes and stabilizer trim. (T-3).

3.6.3.6. IP or AC taking control of aircraft when necessary. (T-3).

3.6.3.7. Unplanned go-around using all throttles. (T-3).

3.6.4. See **Table 7.1** for limitations on simulated emergency procedures in the traffic pattern. Do not practice landings with less than 100 percent flaps, except as noted in **Table 7.1**. (T-2).

3.6.5. Do not perform taxi back landings on wet runways. (T-3).

3.6.6. VFR overheads are authorized.

3.7. Postflight.

3.7.1. The crew will debrief with intelligence immediately after landing IAW the directives for the combatant command that their mission supported. If there is no guidance from the supported combatant command, at a minimum the crew will debrief with intelligence whenever encountering hostile or suspected hostile action during a mission. (T-3).

3.7.2. Flight crews will attend the maintenance debrief and will conduct a crew and a formation debrief IAW procedures defined in the local **Chapter 8** of this manual. (T-3). Complete all appropriate post-mission paperwork and turn it in as required. Units must ensure this paperwork is distributed to the proper agency in a timely manner. (T-3).

Chapter 4

INSTRUMENT PROCEDURES

4.1. Navigation. The B-52 is approved to use inertial navigation system (INS) for enroute RN Area Navigation (RNAV). RNAV approaches have not been adopted for use by the USAF and will not be flown.

4.2. Simulated Instrument Flight. Use of vision restricting devices to simulate instrument flight is prohibited. (T-3).

4.3. Airborne Radar Directed Approach (ARDA). In an emergency, it is possible for the WSO team to direct the pilot through a safe non-precision approach. When aircrew request to practice an ARDA, they must meet the following conditions:

4.3.1. Use a Department of Defense (DOD) FLIP terminal approach procedure with a designated FAF. (T-3). This does not restrict accomplishing an ARDA when cleared for a visual approach from the radar pattern provided VFR conditions can be maintained.

4.3.2. Obtain an ARTCC clearance for the specific approach procedure selected. (T-0).

4.3.3. Advise the appropriate ARTCC facility that the ARDA will be flown along with the requested DOD FLIP terminal approach, if applicable. (T-3).

4.3.4. VMC weather conditions must prevail from the final approach fix (FAF) to the missed approach point (MAP). (T-3). ARDA under lower weather minimums is restricted to emergency conditions when no other type of approach is available. (T-3).

4.3.5. Terminate the ARDA and resume pilot navigation if it becomes apparent that the aircraft will exceed the parameters established for terminal instrument procedures (TERPs). (T-3).

Chapter 5

AIR EXPENDABLES EMPLOYMENT

5.1. General. This chapter establishes procedures for B-52 expendable usage. Also reference AFI 11-214 and Chairman, Joint Chiefs of Staff Manual (CJCSM) 3212.02., *Performing Electronic Attack in the U.S. & Canada for Tests, Training and Exercises*. Units will develop procedures to handle hung/hot flare situations. (T-2).

5.2. Training Flare Drop Activity. The following applies to non-contingency operations only.

5.2.1. Conduct live flare drop activity only in authorized special use airspace contained in current FLIP planning documents and overwater firing areas. (T-2).

5.2.2. Do not drop flares if uncertain of aircraft position. (T-3). If practical, survey the fallout areas visually and with radar before and during all flare drops. (T-3).

5.2.3. Safety Precautions.

5.2.3.1. Do not power the flare ejector system until inside an approved flare drop area. (T-3).

5.2.3.2. Flare activity will be suspended or terminated whenever the aircrew is unable to sufficiently ensure safe conduct of the activity. (T-3).

5.2.4. A right hand empty light on the ALE-20 control panel should illuminate when all flare stepper switches have been activated and flares are dispensed. The light does not guarantee all flares have been expended. Therefore, do not accomplish low approaches or touch-and-go landings after making or attempting a flare drop. Touch-and-gos are authorized after munitions specialists confirm all flares were dispensed (none remaining). (T-3). Do not attempt a taxi-back sortie with confirmed hung, retained, or misfired flares. (T-3).

5.3. Inadvertent Release. In case of any inadvertent or uncommanded flare drop, take the following actions. The waiver authority to waive any of the following actions is the Squadron Commander.

5.3.1. Immediately safe the flare ejector system. Flares may still be used in self-defense. (T-3).

5.3.2. Record time and geographic coordinates of the inadvertent release. (T-3).

5.3.3. Contact the applicable airspace controller and advise them of the incident, approximate location, estimated or observed burnout altitude, and any observed ground contact or damage. (T-3).

5.4. Self-Defense Employment. During contingency operations, the mission planning cell (MPC) will identify high-risk areas and make recommendations for expendable settings and use based on SPINS, local procedures and burnout altitudes. (T-3).

5.5. Chaff. Aircrew will brief chaff employment restrictions to include range restrictions and AFI 11-214 guidance prior to training sorties with chaff loaded. (T-3).

Chapter 6

AIR-TO-GROUND WEAPONS EMPLOYMENT

6.1. References and Authorities. AFI 11-214 contains air-to-surface procedures applicable to all aircraft. Also, reference other applicable instructions, range guides, exercise or theater directives and SPINS. This chapter specifies additional procedures or restrictions applicable to B-52 operations.

6.1.1. Ensure all employment of actual weapons is properly authorized and cleared. (T-0).

6.1.1.1. Authorization to employ weapons for training is given by the wing commander, typically by the 21-165 process. In combat, contingency operations and certain HHD exercises, authorization is given via the ATO, EXORD or similar orders.

6.1.1.2. Aircrew must coordinate final target designation (if not previously received) and clearance to release with ATC, range agencies, and operational and/or tactical controllers (e.g., AOC, JTAC/TACP/FAC, etc.) as applicable. (T-0).

6.1.2. Units will ensure crewmembers are qualified and proficient, or properly supervised, prior to employing actual weapons (T-1). When employing actual weapons, qualified or supervised crewmembers must occupy primary crew positions. (T-2). When carrying nuclear weapons, mission-ready crewmembers must occupy basic crew positions. (T-1).

6.1.3. Each mission involving actual weapons will reference current range guidance and will coordinate number and type of weapons and assigned targets. (T-3). Any exceptional arrangement or waiver for an actual weapons release will be documented in writing. (T-3).

6.1.4. On test sorties, specific portions of this chapter may be waived by instructions contained in the operations order, test plan, or implementation message which directs the test.

6.1.5. Direct questions concerning weapon ranges and restrictions to the local squadron weapons office or AFGSC, Weapons and Tactics (AFGSC/A3TW) if unable to find the responsible agency.

6.2. Definitions.

6.2.1. Weapon. Any high explosive (HE), inert, or training munition. This includes any releasable store -- HE, inert, or other (e.g. MALD) -- but excludes chaff and flares.

6.2.2. High Explosive Weapon. An actual weapon configured with live functioning fuses (i.e. having a live primer mated with electrical power) or high explosives. Planners and crews should be alert for differing usage of "live," as in some instances it may be used by other agencies to denote an actual weapon (e.g. "live" vs. "virtual" or "simulated"). When appropriate, further clarify by describing the weapon as high-explosive.

6.2.3. Inert weapon. An actual weapon that does not have a functioning fuse or high-explosive. This includes weapons with functioning guidance systems (e.g. LGB seekers/tail kits), avionics and/or propulsion. If a weapon is used with inert submunitions that will separate, it is still considered inert but care should be taken to ensure involved agencies know the submunitions will disperse and to describe any charges used in the weapon's function.

6.2.4. Training weapon. A weapons that should be reserved for inert weapons or training aids whose anticipated purpose is for ground training.

6.2.5. Attempted Release. Aircrew have properly configured for release (or jettison) and the bombing system has issued a release pulse or command.

6.2.6. Retained Weapon. Weapons on board the aircraft with no release attempt or after successfully releasing the intended number of weapons in a partial load. For example, an aircraft with nine Mk-82s plans to drop three bombs on each of three targets. Due to weather it attacks only one target. The aircraft now has six retained weapons. Weapons not released due to procedural error are considered retained.

6.2.7. Hung Weapon. A weapon that fails to separate from the aircraft after an attempted release.

6.2.8. Unconfirmed Hung. A term used to communicate uncertainty that could not be resolved airborne. This is not an official status. Crews that suspect hung weapons will follow hung weapons procedures. (T-3).

6.2.9. Visual Confirmation. Confirmation of actual weapon status (weapons away, weapons retained, weapons hung) by either definitive observation of weapons impacts or of weapons in flight/fall, or definitive inspection of stations where weapons are/were loaded, or both. "Naked eye" observations (as opposed to high-res video w/playback) is generally limited to single or isolated weapons/impacts, or weapons stations reliably visible from the cockpit. In all cases, each weapon must be spotted/all involved stations must be inspected. (T-3).

6.2.10. Weapons Interface Unit (WIU) Weapon. Any weapon type utilizing the AIU system with an MIU or WIU to facilitate a release. WIU weapon releases are verified if the respective SMO display for that weapon shows "AWAY" without a "HUNG" fault indication. OAS messages (e.g., "xy:HUNG") and displays (Stores Summary and Weapon Status pages) indicate a hung weapons status.

6.2.11. Radar Interface Unit (RIU) Weapon. Any weapon type utilizing the DBRIC, Release Circuits Disconnect (RCD), and RN station Bomb Indicator Lights to facilitate a weapon release. RIU weapon releases are verified if the bomb indicator lights at the RN station are consistent with DBRIC settings for that release. If corresponding lights do not extinguish following an attempted release, crews should consider themselves hung.

6.3. Planning Guidance.

6.3.1. Releases may be performed only within a designated training range, approved weapons release area, or approved salvo area. In contingency operations, weapons may be employed on previously coordinated/assigned targets or on targets designated by appropriate release authorities (e.g., AOC, JTAC/TACP/FAC, etc.). Crews must be briefed on and comply with no-fly/no-fire areas and collateral restrictions, and during execution should ensure that target areas are consistent with the overall operational picture. (T-2).

6.3.2. Aircrew will ensure system accuracy prior to weapon release. (T-3). Methods to ensure system accuracy include target or aimpoint verification using the radar or targeting pod. Do not release weapons if any doubt exists as to the accuracy of the bombing system. (T-2).

6.3.2.1. Adhere to theater guidance and SPINS for GPS FOM and OAS buffer restrictions. (T-3).

6.3.3. B-52 aircrew may employ weapons in IMC or through an undercast layer provided they comply with applicable restrictions in the range supplement, SPINS, or release authority instructions.

6.4. Target Data Verification. Ensure targets are positively identified and friendly/collateral damage concerns are mitigated. A minimum of two crewmembers will verify OAS, Targeting Pod, or Link targeting parameters as programmed for release. (T-3).

6.4.1. If functioning, the pilots should confirm weapon type, number of weapons, bomb code and target coordinates via the Weapons Summary Screen (WSS) or appropriate CONECT display, for all weapon releases. Reading coordinates between compartments is not required if pilots and offense are able to independently confirm coordinate accuracy (T-3).

6.4.2. All crewmembers should still use any means available to independently confirm weapon accuracy, when able. (T-3).

6.5. Inflight Procedures.

6.5.1. Do not open bomb bay doors during flight with internal weapons on board other than for intentional release or jettison. Open doors only in airspace cleared for release, and over a weapons employment area. (T-3).

6.5.2. When carrying weapons, pre-release or retained, do not conduct approach to stall, simulated engine loss procedures, or other potentially hazardous activity. (T-2). Carrying weapons does not preclude accomplishing fighter intercept exercises (FIEs, see 6.5.5 below), air refueling, or transition excluding simulated engine loss procedures and touch-and-go landings.

6.5.3. Accomplish "Weapons Preparation for Release" check over open water or sparsely populated areas when practical. (T-3).

6.5.4. Do not complete the release configuration check until the aircraft is within the designated bombing range. (T-3). For contingency operations, accomplish as directed by SPINS or in a location that minimizes risk of friendly/collateral damage (e.g. over water/sparsely populated areas/known hostile territory). When able, minimize time between configuration check and actual releases. (T-3).

6.5.5. While carrying weapons configured for release (Release Configuration Check Complete), do not conduct fighter intercept exercises (unless planned as part of an exercise and conducted in range airspace), simulated weapons runs, transition, or air refueling (unless operationally necessary). (T-3).

6.5.6. Training Restrictions.

6.5.6.1. Do not accomplish external simulated weapons training (activity in SIM or PART SIM mode) with external weapons loaded. (T-2). Do not accomplish internal simulated weapons training with internal weapons loaded. (T-2).

6.5.6.2. Crews shall accomplish external simulated weapons training with internal weapons loaded, or internal simulated training with external weapons loaded under the following conditions:

6.5.6.2.1. The OAS will be reloaded with a FERRY mission. (T-2).

6.5.6.2.2. The weapons simulated will be a different SMO from the weapons loaded. (T-2).

6.5.6.2.3. There will be no SMO loaded at the location where weapons are present and the associated WIU/MIU will remain off. (T-2).

6.5.6.3. After positive verification of release of all weapons, aircrew may conduct additional training without restrictions.

6.5.7. Recovery. If internal weapons were carried, do not open the bomb bay doors unless/until cleared by maintenance. (T-3).

6.6. Release Verification.

6.6.1. The primary means of release verification is cockpit indications, as defined for WIU/RIU releases (paragraphs 6.2.10 and 6.2.11.). However, aircrew will obtain and consider all readily available sources of information (targeting pod, ground party reports, wingman reports, etc.) when assessing weapon release or system malfunctions. (T-3). If contradictory indications are found and cannot be resolved, crews should follow hung weapons procedures.

6.6.2. Training. Visual confirmation between weapon releases is not required as long as the OAS/bomb indicator lights do not indicate (a) hung weapon(s). Aircrew with hung weapon indications will follow hung weapons procedures unless/until their status is changed. (T-3).

6.6.3. Contingency Operations. Requirements for visual confirmation and hung weapons procedures may be adjusted based on theater commander guidance, SPINS, and local procedures. If mission priorities and ALR justify the risk (if any) of inadvertent release, store-to-store or store- to-ship contact, the AC may continue releases if hung indications exist. Crews will attempt to confirm and/or correct the issue when able, and follow hung weapon procedures for recovery. (T-3).

6.6.4. For RIU weapons, aircrew should obtain visual confirmation prior to departing the range or employment area. If the aircrew cannot obtain visual confirmation that no weapons are hung, they will adhere to hung weapons procedures unless/until their status is changed. (T-2).

6.6.5. If a range control officer (RCO)/ground party and/or targeting pod (TGP) video are available and fail to spot a weapon, crews will assess the possibility of a dud, low-order detonation, or a weapon falling off target. (T-3). If such assessment casts doubt on weapons or weapon system reliability, discontinue releases unless mission priorities and ALR justify continuing. (T-3). In all cases, attempt to spot the actual impact, capture applicable data and report to appropriate agencies during/after flight. (T-3).

6.7. Weapon Jettison. Aircrew will brief jettison contingencies, applicable restrictions, and weapon- specific procedures during crew or step brief. (T-3) Attempt a weapons jettison if required for safety of flight, operational requirements, or if there is concern that a hung weapon may separate. If hung weapons are not jettisoned, the crew will accomplish the post release/abort checklist and return directly to home station or other suitable landing base. (T-3).

6.7.1. Training. If hung indications are encountered, contact the RCO for authorization to release or jettison hung weapons in a suitable area, if local guidance allows. Follow range rules, RCO instructions and technical order guidance. (T-1).

6.7.2. Contingency Operations. Hung weapons may be jettisoned IAW SPINS and/or HHD/local guidance.

6.8. Hung Weapon Procedures. If a weapon is known or suspected to be hung and cannot be visually confirmed to have separated from the aircraft, comply with the following. If a jettison is appropriate and can be visually confirmed, or hung indications are resolved by visual confirmation, leaving only retained weapons or no weapons, crews may return to normal guidelines. 1760 weapons that do not display “xy:HUNG” should be considered retained. Advise maintenance personnel on landing and annotate in forms. (T-3).

6.8.1. Do not attempt any further releases, except as provided in [paragraph 6.6.3](#). (T-3).

6.8.2. If necessary, accomplish the bomb bay check. Due to risk to personnel, such checks should not be attempted unless a specific compelling need exists to enable additional releases or follow-on activity rather than applying hung weapons restrictions. (T-2).

6.8.3. During recovery, comply with restrictions for carried weapons. Additionally, accomplish air refueling only if required to recover the aircraft. (T-3). Do not rotate the CRL/CSRL. (T-3). Avoid overflight of populated areas, do not accomplish simulated emergency training, and fly a single approach to a full stop. (T-2).

6.8.4. Aircraft with hung weapons will declare an emergency prior to landing (T-3). Aircrew with hung weapons will accomplish a ground weapons check with maintenance immediately after landing and will follow locally developed guidance for safe recovery and de-arming. (T-3).

6.9. Targeting Pod (TGP) Restrictions. Minimum altitude for use of turret-based targeting pods is 1,000 feet AGL (e.g. LITENING). (T-3).

Chapter 7

ADDITIONAL OPERATIONAL LIMITS AND RESTRICTIONS

7.1. New/Modified Aircraft Equipment/Weapons. Crewmembers not qualified in the operation of new or modified aircraft equipment are restricted in aircrew duties as follows:

7.1.1. They will not be placed on alert with an aircraft so equipped or modified. (T-2).

7.1.2. They will not operate that equipment on any flight unless supervised IAW the supervisory requirements of the syllabus, training plan, or squadron commander. (T-2).

7.2. Fuel Quantity Indication System Failure. During peacetime missions, each fuel quantity indicator for each fuel tank must be fully operational. (T-3). Exceptions:

7.2.1. When a standard fuel load results in one or more empty tanks, the respective fuel quantity indicator for the empty tank need not be fully operational provided:

7.2.1.1. The tank will remain empty throughout the flight, including inflight refueling.

7.2.1.2. The fuel quantity gauge indicates zero.

7.2.1.3. The circuit breaker for the respective indicator is pulled and a safety clip installed to prevent inadvertent resetting.

7.2.2. Aircraft may be flown with one external or one outboard, but not more than one total tank gauge, wing tank gauge inoperative or malfunctioning, provided the following procedures are adhered to:

7.2.2.1. The aircraft is loaded with a standard fuel load. (T-3).

7.2.2.2. The circuit breaker for the inoperative or malfunctioning gauge is pulled and a safety clip installed to prevent inadvertent resetting. In this situation, the pilots must realize that regardless of the gauge indication, the total fuel quantity indicator will be receiving indications that the tank is empty. Therefore, there will be a discrepancy between the total fuel quantity indication and the actual amount of fuel on board. (T-3).

7.2.2.3. The fuel flow indicator for that tank is fully operational. (T-3).

7.2.2.4. Pilots must be vigilant when using fuel from a tank having an inoperative or malfunctioning fuel gauge since the only indication of fuel flow will be the fuel flow indicator light, lateral trim indications, and balance of fuel between main tanks one and four. (T-3).

7.3. Takeoffs and Critical Phases.

7.3.1. Takeoffs with one or more engines inoperative from start of takeoff roll are prohibited. (T-2).

7.3.2. During emergency evacuation, takeoff with one or more engines inoperative may be accomplished at the discretion of the wing commander or if directed by higher headquarters. wing commanders or higher headquarters may authorize actual RCR (or 12 if it cannot be measured) for wet runway takeoff data computations in emergency conditions.

7.3.3. An A-coded pilot must occupy a primary seat during all critical phases of flight. (T-3). For weapons releases, an IP may supervise two pilots (neither with an A-code) from the IP seat. (T-3).

7.4. Unusual Attitudes and Stalls. Unusual attitudes and stalls are prohibited. (T-0).

7.5. Initial Buffet.

7.5.1. Perform all inflight initial buffet practice as prescribed in the flight manual and under IP supervision (pilot in a primary seat). (T-3).

7.5.2. Pilots must review and discuss the correct recovery procedures and limitations for accomplishing initial buffet with the crew during mission planning. (T-3).

7.5.3. Practice recovery from initial buffet at a minimum altitude of 20,000 feet above the terrain. If clouds exist between the aircraft and the terrain, the aircraft must be at least 10,000 feet above the tops of the clouds. Do not practice recovery from initial buffet above FL 300 or at gross weights above 300,000 pounds. (T-3).

7.5.4. Perform the entire initial buffet maneuver with wings level. (T-2).

7.5.5. Do not practice initial buffet with weapons or missiles loaded. (T-2).

7.6. Fuel Minimums. The fuel reserve requirements of AFI 11-202 Vol 3 apply as augmented below:

7.6.1. Emergency fuel is 12,000 pounds in the main tanks. Minimum fuel is 20,000 pounds in the main tanks. Ballast fuel required in auxiliary tanks cannot be considered part of emergency or minimum fuel. Crews will land at or above minimum fuel. (T-2). If at any point in flight the crew expects to land below emergency fuel, adjust the profile (to include diverting, as needed) and/or declare an emergency. (T-3).

7.6.2. Standard recovery fuel is 40,000 pounds. This is a general planning factor, and may be increased based on alternate requirements, follow-on missions, or other factors. If an alternate is required, fuel may be planned based on diverting to then landing at the alternate with minimum fuel – standard recovery fuel need not be applied.

7.6.3. For remote or island destinations, the planning factor is 54,000 pounds. This may be reduced if an alternate is not required and minimum fuel is assured.

7.7. Emergency Limitations.

7.7.1. Contact the unit or controlling command post when encountering emergencies. This should not interfere with immediate concerns dictated by the situation (i.e. aircraft control, checklist procedures, etc.). Consider using the supervisor of flying (SOF), Duty IP, or other agencies (e.g. Boeing) for assistance. (T-3).

7.7.1.1. Informing ATC of an emergency should be accomplished after critical actions at a minimum, and may be delayed until shortly prior to landing unless assistance is needed. If immediate maneuvering is required (e.g., emergency descent), consider switching IFF to 7700 when able.

7.7.1.2. Aircrew may squawk 7600 if effective communication with ATC is lost (e.g., excessive interference), even if radios are still operative.

7.7.2. In an actual emergency, terminate all training and emergency procedures practice. Crewmembers will return to their respective crew positions and remain there unless operational requirements or the nature of the emergency dictate otherwise. Resume training only when the pilot in command determines no hazard to safe aircraft operations exists. (T-3).

7.7.3. If aborting the mission only limited training is authorized while flying to the recovery field and/or reducing gross weight for landing. Low-level, fighter activity, air refueling (unless required for safe recovery of the aircraft) and transition are prohibited. (T-3).

7.7.4. If continuing the mission, identify and mitigate the effects on the mission of the malfunction(s), especially those that result in:

7.7.4.1. Loss of pressurization.

7.7.4.2. Loss of mapping radar and weather avoidance capability.

7.7.4.3. Loss of navigation capability.

7.7.4.4. Degraded instrument capability.

7.7.4.5. Potential effect of multiple or compound equipment malfunctions.

7.7.5. If it becomes necessary to shut down two or more engines, or one engine for fire or fire indication, abort the mission. Aircraft with confirmed or suspected fuel leaks will abort the mission. (T-3).

7.7.6. Aircrew should declare an in-flight emergency (IFE) for any of the following situations:

7.7.6.1. Any time an aircraft malfunction requires priority or special handling by ATC. This does not include equipment malfunctions with procedural implications (e.g., transponder inoperative) rather than direct safety concerns.

7.7.6.2. Any time an Emergency Procedure (EP) checklist states “land as soon as possible.”

7.7.6.3. Any situation where aircrew refer to a technical order emergency checklist that directs additional/alternate procedures or restrictions for landing.

7.7.6.4. In any case where current or foreseeable system failures could make immediate ground assistance (e.g., fire, medical, maintenance, supervision) advisable.

7.7.6.5. Any engine loss, fire, fuel or flammable leak, or complete electrical failure, even if it appears to have been resolved.

7.7.6.6. If any doubt exists in the opinion of the aircrew or SOF about the safety of the aircrew or aircraft’s performance.

7.8. Inflight Simulated Emergency Procedures.

7.8.1. Brief all practice maneuvers or emergency procedures before the maneuver (either inflight or during mission planning). The pilot should alert all crewmembers prior to all maneuver demonstrations or inflight emergency procedures practice. (T-3).

7.8.2. Do not practice compound emergencies during critical phases of flight except those specifically authorized for flight instructor course (FIC) training. See [Table 7.1](#) for additional simulated emergency restrictions. (T-2).

Table 7.1. Simulated Emergency and Transition Limitations.

Maneuver	Max Wt	Weather	IP Supervision (IP in a primary	Additional Restrictions	Remarks
Simulated Engine Loss on Takeoff	290,000 lbs	Note 6	Required	N/A	Limited to one engine simulated inoperative above S-1 speed or 100 KIAS, whichever is higher. Dry runway. Max 10 kt crosswind component.
Simulated Six Engine Approach	290,000 lbs	Note 1	Required for other than day VFR	Note 2	
Simulated Six Engine Landing	290,000 lbs	Note 1	Required	Note 3	Dry runway. Max 10 kt crosswind component.
Simulated Six Engine Approach and Go-Around (Symmetric)	270,000 lbs	Note 1	Required for other than day VFR	Note 2	
Flaps Up Approach	290,000 lbs	Note 1	Required for other than day VFR	Notes 2 & 5	
Flaps Up Touch-and-go	250,000 lbs	Note 1	Required	Notes 2, 4, 5, & 8	Qualified Instructor Required. No gusty winds.
Low Approaches with One Engine Shut Down	290,000 lbs	Note 1	Required for other than day VFR	Note 2	Prohibited if engine(s) was shut down for fire, fire indication, or fuel leak.
Traffic Pattern Operations	325,000 lbs				
Landing Attitude Demonstration	290,000 lbs	Day/Night Note 6	Required		Flaps down, touch-and-go limitations apply

Simulated Rudder/Elevat or Out Approach	270,000 lbs		Required	Notes 2 & 8	Qualified Instructor Required. Avoid turbulence. Resume normal control inputs immediately if excessive deviations occur.
Two-Engine Go-Around Capabilities	250,000 lbs		Required	Notes 7 & 8	Qualified Instructor Required.

Notes:

1. Day/Night. No lower than circling minimums or 1,000 feet ceiling and 3 miles visibility (2 miles if under radar contact), whichever is higher.
2. 200 feet Height Above Touchdown (HAT) or Decision Height (DH)/Minimum Descent altitude (MDA) for the approach being flown, whichever is higher.
3. Comply with the following if a touch-and-go is to be accomplished: Touch-and-go limitations apply. No other simulated emergencies may be practiced during the maneuver. Rudder trim must be centered when decision is made to land. Eight engine symmetrical thrust must be used for takeoff. If unplanned go-around is executed, symmetrical thrust will be established on all engines. **(T-2).**
4. Dry runway crosswind component is 10 knots maximum. Touchdown must be made in the first third of the runway or go-around will be initiated. **(T-2).**
5. 200 feet AGL to make decision to land or go-around.
6. Discernible horizon and the end of the runway visible.
7. Initiate go around no lower than 200 AGL for flaps up and 800 AGL for flaps down two-engine go-around capabilities demonstrations.
8. Operations group commander approval required if accomplished outside of formal syllabus. "Qualified Instructor" is defined as a FIC instructor or an instructor trained by FIC cadre and certified by the operations group commander.

Chapter 8

LOCAL OPERATING PROCEDURES

8.1. General. Distribute this chapter to MAJCOM/NAF OPRs, as applicable. Specific items should include, but need not be limited to, the following:

8.1.1. Purpose

8.1.1. **(MINOTAFB)** Purpose. This chapter establishes 5 BW B-52 local operating procedures.

8.1.2. Applicability

8.1.2. **(MINOTAFB)** Applicability. This chapter applies to all 5 BW B-52 operations and aircrew.

8.1.3. Recommended Changes

8.1.3. **(MINOTAFB)** Recommended Changes. Submit change requests to 5 OG/OGV using the AF Form 847. The waiver authority for this publication is the 5th Operations Group Commander (5 OG/CC).

8.1.4. Normal Operating Procedures

8.1.4.1. **(Added-MINOTAFB)** Coordination and Mission Planning

8.1.4.1.1. **(Added-MINOTAFB)** Plan and execute all missions IAW the daily B-52 schedule. Any personnel changes from the published schedule prior to the day of flight require a Squadron Assistant Director of Operations (SQ/ADO) or higher approval.

8.1.4.1.2. **(Added-MINOTAFB)** All personnel changes to the daily flying schedule on the day of flight require approval by the Operations Supervisor (Ops Sup/Top3). The Ops Sup will brief the SQ/DO or SQ/CC of any personnel changes.

8.1.4.1.3. **(Added-MINOTAFB)** Do not schedule aircrew for any activity for a period of 12 hours after scheduled land time without SQ/DO approval.

8.1.4.1.4. **(Added-MINOTAFB)** If taking off more than 30 minutes late, AC's will plan to fly duration. Advise the Ops Sup/SOF of updated late land time for coordination with the Maintenance Production Supervisor. If planned training cancels, or other conditions arise, the crew may request CHARLIE approval to land as scheduled or later when training is complete. Formations will not sympathetic delay beyond 30 minutes unless necessary to meet mission requirements.

8.1.4.1.5. **(Added-MINOTAFB)** Sortie Cancellation. ACs are the final authority for operation of their assigned aircraft per AFMAN 11-202v3 paragraph 2.3.. ACs may cancel a sortie due to safety concerns in coordination with the Ops Sup. When excessive training degradations occur, the AC may request approval to cancel from CHARLIE. Any sorties delayed more than 4 hours past the planned takeoff require CHARLIE approval or are cancelled.

8.1.4.1.6. **(Added-MINOTAFB)** Sortie Types

8.1.4.1.6.1. **(Added-MINOTAFB)** Mission Plan-Fly (MP-F). Sorties in which aircrew generate all mission materials and conduct appropriate briefings on mission planning day. Re-accomplish the Mission Brief (MB) if not executed within 72 hours. Upgrade or formal syllabus sorties should use MP-F procedures.

8.1.4.1.6.2. **(Added-MINOTAFB)** Show-n-Go Mission Planning Cell (SNG-MPC). Sorties in which an MPC generates all mission materials and provides the MB. After the MB, aircrew will conduct all other necessary briefings and execute the mission the same day. Focus is on employing tactics that maximize an aircrew's combat capabilities.

8.1.4.1.6.3. **(Added-MINOTAFB)** Show-n-Go Off-the-Shelf (SNG-OTS). Sorties in which the Squadron Weapons and Tactics Flight provides mission materials. Aircrew modify the mission materials for mission requirements, conduct appropriate briefings, and execute the mission within the same day. SNG-OTS sorties and products are not permitted when conducting HE/inert weapons events. For all HE/inert weapons events utilize MP-F or SNG-MPC sorties and products.

8.1.4.1.6.3.1. **(Added-MINOTAFB)** Squadron Weapons and Tactics Flight will generate generic mission materials and save on the 5 OG secret standalone network (BUFFNET) to minimize aircrew mission planning on flight date.

8.1.4.1.6.3.2. **(Added-MINOTAFB)** OGV will maintain Stereo routes coordinated with ATC for front lines to PR2 without AR and Standard Low Level charts for local IR routes.

8.1.4.1.6.4. **(Added-MINOTAFB)** Pilot-Proficiency Sortie (PPS). Sorties focus on pattern training and/or air refueling. Crews will generate all mission materials, conduct appropriate briefings and execute the mission within the same day. PPS sorties are typically planned as Engine Running Crew Change (ERCC) outputs and will use the time lines directed in [Table 8.1](#).

Table 8.1. (Added-MINOTAFB) Training Mission Pre-Takeoff Timeline.

	Show	Step Brief	Bus	Eng Start
MP-F, SNG-MPC, SNG-OTS ^{1,2,3}	As Req	2+00	1+45	0+40
ERCC4	As Req	1+15	1+00	N/A
Quick Turn5 (≤90k refuel)	As Req	2+15	2+00	As Req
Quick Turn5 (>90k refuel)	As Req	2+45	2+30	As Req
NOTES: Add 0+15 to step brief and bus times during winter operations (1 Nov - 31 Mar) and/or for sorties containing weapons loads greater than nine to allow for weapons preflight. Add 0+10 to engine start during winter operations. Add 0+30 to all times for alert/quick taxi starts. ERCC output bus time is scheduled for input land time. See Attachment 7 Quick Turn output bus time is at the input scheduled land time. See Attachment 7				

Table 8.2. (Added-MINOTAFB) HHD Mission Pre-Takeoff Timeline.

	Show	Msn Brief	Step Brief	Arming	Bus	Eng Start	Crew Swap
Preflight ^{1,2,3}	As Req	As Req	2+25	N/A	2+20	1+15	0+50
Flight Crew ³	As Req	3+45	1+45	1+30	1+00	N/A	0+50

NOTES:
 Add 0+15 to step brief and bus times during winter operations (1 Nov - 31 Mar) and/or for sorties containing weapons loads greater than nine to allow for weapons preflight.
 Add 0+10 to engine start during winter operations.
 See 5 OG HHD Standards for additional information.

8.1.4.1.7. **(Added-MINOTAFB)** Prior to scheduled air refueling activity the Lead Planner (LP) or designated aircrew member will contact the respective refueling unit(s) to confirm the following: air refueling track, rendezvous type/point, control time, base altitude, off-load, EMCON, number of tankers, tanker call sign, and any slip capability.

8.1.4.1.8. **(Added-MINOTAFB)** Fuel Planning.

8.1.4.1.8.1. **(Added-MINOTAFB)** The primary takeoff alternate is Ellsworth AFB. If Ellsworth is unavailable, the Ops Sup will set a suitable alternate for each day based on weather.

8.1.4.1.8.2. **(Added-MINOTAFB)** Flight Schedulers and higher headquarters mission MPCs shall request fuel quantities so missions arrive at the Minot AFB IAF with at least 50,000 lbs (70,000 lbs from 1 Nov - 31 Mar). ACs will ensure that AFMAN 11-202v3 fuel requirements and minimums in Para 7.6. are met. Crews may recover with less than 50,000 lbs (70,000 lbs from 1 Nov - 31 Mar) if required to meet operational/training objectives after reviewing the status of home station and alternate airfields weather.

8.1.4.1.9. **(Added-MINOTAFB)** Reduced Vertical Separation Minima (RVSM) Procedures. Non-RVSM-compliant aircraft will use the following to coordinate access to RVSM airspace prior to flight:

8.1.4.1.9.1. **(Added-MINOTAFB)** Coordinate with the 5 BW Airspace Management Office during mission planning for Letter of Agreement (LOA)/Memorandum of Understanding (MOU) procedures.

8.1.4.1.9.2. **(Added-MINOTAFB)** Annotate RVSM airspace requests in final level off block, or remarks section (e.g., "Request CROSSBOW ATCAA FL270B310 Non-RVSM E1700X1800").

8.1.4.1.9.3. **(Added-MINOTAFB)** Coordinate for approval with the 5 BW Airspace Management Office for missions that require access to RVSM airspace (e.g. fuel considerations).

8.1.4.1.9.4. **(Added-MINOTAFB)** Whenever RVSM denial affects mission accomplishment, the AC (or Flight Lead) will file a RVSM denial form with the 5 BW Airspace Management Office.

8.1.4.2. (Added-MINOTAFB) Grade sheets

8.1.4.2.1. (Added-MINOTAFB) For all flight and WST events when syllabus training is conducted, the assigned instructor will submit a Grade sheet to Squadron Training Flight no later than (NLT) two business days from the event to ensure timely documentation of training/student performance.

8.1.4.2.2. (Added-MINOTAFB) Any time an instructor, SQ/CC, or SQ/DO determines past or current non-syllabus training performance (substandard or commendable) warrants documentation, inform squadron leadership at the appropriate level and submit a Grade Sheet to Squadron Training Flight.

8.1.4.3. (Added-MINOTAFB) Pre-Takeoff.

8.1.4.3.1. (Added-MINOTAFB) Required Publications.

8.1.4.3.1.1. (Added-MINOTAFB) Aircrew will ensure that EFBs have the most recent currency of Technical Orders (T.O.s) and directives prior to flight.

8.1.4.3.1.2. (Added-MINOTAFB) See [Attachment 10](#) for T.O. requirements.

8.1.4.3.2. (Added-MINOTAFB) In addition to the briefings required by AFMAN 11-2B-52v3, the AC will complete the Operations Risk Assessment Matrix and brief the crew on mitigating areas of concern. If any risk factor is rated high, the AC will obtain the Ops Sup's initials in that area. If the overall risk assessment is rated as high or extreme, ACs will inform the Ops Sup, thoroughly brief all factors causing the increased score and proposed mitigation, and obtain the appropriate signature IAW the ORM matrix.

8.1.4.3.3. (Added-MINOTAFB) Flight Plan Filing Procedures. Crews will file in the following priority order: 1) Hard copy DD Form 1801 given to Ops Sup who will route to Base Ops. 2) Delivering a hard copy DD Form 1801 to Base Ops. 3) Electronically file a copy through Foreflight. Crews are not authorized to step without ensuring that the Ops Sup has received an electronic or signed hard copy of the 1801.

8.1.4.3.4. (Added-MINOTAFB) Load Adjuster Policy.

8.1.4.3.4.1. (Added-MINOTAFB) Due to load adjuster (slip stick) availability and durability limitations, aircrew should not bring load adjusters on the aircraft for routine training sorties. Special missions that may warrant checking out a load adjuster include off-station, long duration, or oceanic sorties.

8.1.4.3.4.2. (Added-MINOTAFB) If load adjuster calculations are required for emergency or non-emergency situations (e.g. stepping to an unplanned spare), the primary point of contact (POC) is the Duty Instructor Pilot (DIP). Alternatively, the Ops Sup may utilize the assistance of any qualified pilot for non-emergency situations.

8.1.4.4. (Added-MINOTAFB) Thunderstorms or Lightning During Ground Operations.

8.1.4.4.1. (Added-MINOTAFB) Lightning Watch. Potential exists for lightning within 5 NM of the base within the next half hour. This declaration does not require evacuation of the ramp; however, maintenance personnel will begin preparing their equipment to ensure they can evacuate as soon as a lightning warning is issued.

8.1.4.4.2. **(Added-MINOTAFB)** Lightning Warning. Lightning (i.e. thunderstorm) has been observed within 5 NM of the base. Aircrew shall evacuate the ramp with maintenance personnel or elect to remain in the aircraft. If lightning is expected to remain in the area for an extended period, aircrew may shutdown engines. Aircraft grounding is not required.

8.1.4.4.5. **(Added-MINOTAFB)** Training Quick-Taxi. Quick Taxi using the boldface items of the checklist. Crews will ensure the entire Taxiing and Before Lineup Checklist is completed prior to takeoff.

8.1.4.4.6. **(Added-MINOTAFB)** Generator Operations. Allow oil temperature to reach 40° C prior to turning generators on unless operation needs dictate or when using Quick- Taxi procedures. For cold weather operations consider performing anti-ice checks first to bring oil to temperature faster and leave engines 4 and 5 up for stab trim checks.

8.1.4.4.7. **(Added-MINOTAFB)** Taxi Procedures. Turning the taxi lights ON indicates the aircraft is ready to taxi. Flashing the taxi lights multiple times signals maintenance personnel to return to interphone. Minot AFB taxiway obstruction guidance and figures are provided in [Attachment 9](#).

Table 8.3. (Added-MINOTAFB) Local Radio Standards.

GROUND CALLSIGN	PARTY
WARBIRD	WG/CC
CHARLIE	OG/CC
BOMBER 1	23 BGS Maintenance Pro Sup
HAWK 1	69 BGS Maintenance Pro Sup
ICER CONTROL	Ops Sup/Step Desk during normal ops
ICE KING/AVALANCE	Ops Sup during generations
FOXTROT	SOF
ICEMAN	DIP
RAYMOND 12	Minot Command Post
CHIEF 1	Fire Chief
IRON 1	Munitions Supervisor
FLYING CALLSIGNS	PARTY
WARBIRD 01	WG/CC
WARBIRD 02	WG/CD
ICER 01	OG/CC
ICER 02	OG/CD
IRON 01	OSS/CC
IRON 02	OSS/DO
CHILL 01	23 BS/CC
CHILL 02	23 BS/DO
FEAR 01	69 BS/CC
FEAR 02	69 BS/DO

8.1.4.7.1. **(Added-MINOTAFB)** Radio “Blind Spots” that exist on the ramp may necessitate the use of alternate transmitters to communicate with air traffic control (ATC). Formations may request single-frequency operations with ATC on initial radio check-in to combine ground, clearance delivery, tower, and departure frequencies.

8.1.4.7.2. **(Added-MINOTAFB)** Formations will use **Table 8.3** frequencies and air-to-air TACAN channels for all local training missions. The first scheduled formation of the day will utilize the respective squadron interplane and TACAN. Additional formations will use interplane 1, 2, and 3.

Table 8.4. (Added-MINOTAFB) Formation Frequencies/TACAN.

Flight	Frequencies	A/A TACAN
23 BS Interplane	323.750	23Y/86Y
69 BS Interplane	369.150	18Y/81Y
Interplane 1	252.5	51Y/114Y
Interplane 2	252.7	52Y/115Y
Interplane 3	252.9	53Y/116Y

8.1.4.8. **(Added-MINOTAFB)** Flight Level and Low Outside Air Temperature (OAT) Avoidance. Rather than descending to a lower altitude, aircrew may elect to increase airspeed or climb when encountering indicated outside air temperatures (IOAT) within 5°C above the freezing point of the fuel (-40°C for Jet A++/F-24). Additionally, warmer air may exist above your flight level; contact Pilot Meteorological Service (PMSV) for forecasted temperatures at higher flight levels.

8.1.4.9. **(Added-MINOTAFB)** Transition Training Restrictions

8.1.4.9.1. **(Added-MINOTAFB)** When the weather is less than 500 feet or 1 mile (1,000 feet or 2 miles with only a non-precision approach available), terminate transition before the fuel remaining is less than the fuel required for recovery to the planned divert base.

8.1.4.9.2. **(Added-MINOTAFB)** Bird Watch Condition (BWC) Restrictions

8.1.4.9.2.1. **(Added-MINOTAFB)** See AFI 91-212 MAFBSUP, for BWC definitions.

8.1.4.9.2.2. **(Added-MINOTAFB)** BWC LOW. No restrictions.

8.1.4.9.2.3. **(Added-MINOTAFB)** BWC MODERATE. Only initial takeoffs and full stop landings are allowed.

8.1.4.9.2.4. **(Added-MINOTAFB)** BWC SEVERE. Local training and mission departures and arrivals require approval from the 5 OG/CC or a designated authority.

8.1.4.9.2.5. **(Added-MINOTAFB)** Minot AFB BWC restrictions apply to all 5 BW aircraft, regardless of where transition training is conducted. Prior to step, aircrew will utilize all available Avian Hazard Advisory System (AHAS)/Bird & Wildlife Aircraft Strike Hazard (BASH) tools to determine bird status along the entire route of flight and all transition locations.

8.1.4.9.2.6. **(Added-MINOTAFB)** After observing or encountering MODERATE or SEVERE bird activity, aircrew will contact FOXTROT and pass the following information: location and altitude of birds, time of sighting, approximate number and type of birds, and type of activity (e.g. soaring, flying to/from a specific location).

8.1.4.10. **(Added-MINOTAFB)** Traffic Pattern Icing Restrictions

8.1.4.10.1. **(Added-MINOTAFB)** Definitions. In addition to the definitions below, reference Air Force Handbook (AFH) 11-203v1 Weather for Aircrews, and Flight Information Handbook (FIH) for expanded information on levels of icing intensity.

8.1.4.10.1.1. **(Added-MINOTAFB)** LIGHT. Slight accumulation (one thin layer less than an inch thick) on wipers that remains and does not build; easily handled by windshield anti-icing; no sign of buildup on engine cowls and/or wing leading edges.

8.1.4.10.1.2. **(Added-MINOTAFB)** MODERATE. Buildup on the windscreen, but removed with windshield anti-ice on high setting; accumulation continues to build on wipers; engine cowls and/or wing leading edges are free from ice.

8.1.4.10.1.3. **(Added-MINOTAFB)** SEVERE. Rapid buildup on windscreen even with windshield anti-ice on high setting; engine cowlings and wings show rapid continuing accumulation.

8.1.4.10.2. **(Added-MINOTAFB)** Traffic pattern operations are prohibited in areas of forecast or reported SEVERE icing. Aircrew may execute one approach to a full stop in forecast or reported MODERATE icing.

8.1.4.10.3. **(Added-MINOTAFB)** Aircrew will provide Minot AFB Weather and Approach Control Pilot Reports (PIREPs) if MODERATE or SEVERE icing is reported or encountered.

8.1.4.11. **(Added-MINOTAFB)** Off-Station Transition Restrictions

8.1.4.11.1. **(Added-MINOTAFB)** Aircrew must obtain approval for off-station transition in accordance with [Table 8.4](#). See [para 8.1.4.12.6](#) for additional Minot International Airport restrictions. If annotated on the schedule, approval is granted. If not coordinated prior to or at step in accordance with [Table 8.4](#). Ops Sup approval and CHARLIE notification is required.

Table 8.5. (Added-MINOTAFB) Off-Station Transition Restrictions.

Airfield	Approval	Restrictions
Barksdale AFB	AC	None
Dyess AFB	Ops Sup	Coordinate w/Dyess Base Ops
Ellsworth AFB	AC	None
Fairchild AFB	AC	Low Approaches Only
Fargo International	AC	Low Approaches Only
Grand Forks AFB	AC	Low Approaches Only
Hill AFB	Ops Sup	Coordinate w/Hill Base Ops
McConnell AFB	Ops Sup	Low Approaches Only
Minot International	AC	Low Approaches Only
Mountain Home AFB	Ops Sup	Coordinate w/Mountain Home Base Ops
NAS Fallon	Ops Sup	Coordinate w/Fallon Base Ops
Nellis AFB	Ops Sup	Coordinate w/Nellis Base Ops
Offutt AFB	AC	None
Tinker AFB	AC	None
Whiteman AFB	Ops Sup	Coordinate w/Whiteman Base Ops

8.1.4.11.2. **(Added-MINOTAFB)** Aircrew approved for off-station transition training will thoroughly review and coordinate transition activity during mission planning to confirm runway size, runway load bearing capacity, airfield operating hours, BASH, and equipment support for planned activity.

8.1.4.11.3. **(Added-MINOTAFB)** Bird Condition. See [para 8.1.4.10](#) for required actions and restrictions that apply to off-station transition.

8.1.4.11.4. **(Added-MINOTAFB)** ACs will pass off-station transition location(s) and timeframe(s) to weather personnel during mission planning to ensure accurate weather information is briefed.

8.1.4.11.5. **(Added-MINOTAFB)** Civilian Field Transition Training. (N/A Minot International) Transition requires 5 BW/CC approval. Submit civilian field transition requests to Squadron Flight Scheduling for input into PEX remarks prior to the weekly Wing Stand-Up meeting. This section does not apply to sorties scheduled for “Flyby,” “Air show” or “Aerial Demonstration.” Aircrew will utilize VHF approach and tower frequencies when conducting Civilian Field Transition Training.

8.1.4.11.6. **(Added-MINOTAFB)** Minot International Airport Restrictions.

8.1.4.11.6.1. **(Added-MINOTAFB)** Low approaches (including simulated emergency patterns) to Runway 31/13 are permitted when Magic City Tower is open.

8.1.4.11.6.2. **(Added-MINOTAFB)** Approaches to Runway 08 are not allowed.

8.1.4.11.6.3. **(Added-MINOTAFB)** Approaches to Runway 26 are allowed if circling to Runway 31/13. Circle northeast of Runway 31/13 to avoid over flight of populated areas. Do not request the approach to Runway 26 if reported weather is less than 1,000 feet or 3 miles.

8.1.4.12. **(Added-MINOTAFB)** Cold Weather Operating Procedures.

8.1.4.12.1. **(Added-MINOTAFB)** Snow and Ice Removal. ACs have final decision authority on whether an aircraft should be de/anti-iced or cleared of snow prior to flight. At a minimum, meet the requirements of AFMAN 11-202v3 and 1B-52H-1.

8.1.4.12.2. **(Added-MINOTAFB)** When anti-icing is required, pilots will make the required adjustments to the S2 distance, and the minimum runway required prior to takeoff. See 1B-52H-1-1 for details.

8.1.4.12.3. **(Added-MINOTAFB)** See [Attachment 12](#) for further reading on de/anti-icing.

8.1.4.12.4. **(Added-MINOTAFB)** Cold Weather Engine Ground Operations.

8.1.4.12.4.1. **(Added-MINOTAFB)** Induction Icing. Aircrew shall use caution if the ATIS is reporting any potential icing conditions. Induction icing is the formation of ice in an aircraft's engine air intake, restricting airflow and causing power loss, affecting jet engines (inlet icing). This advisory is issued by 5 OSW when the temperature is $\leq 47^{\circ}\text{F}$ with visibility < 1 SM OR dew point depression $\leq 4^{\circ}\text{F}$ OR visible moisture present. Aircrew may start and operate engines on the ground during induction icing advisories but shall shut down engines as soon as practicable if ice is observed forming on the B-52 engine inlets.

8.1.4.12.4.2. **(Added-MINOTAFB)** Freezing Fog/Precipitation. Freezing fog is an advisory issued by 5 OSW when the temperature is $\leq 32^{\circ}\text{F}$ with visibility $< 5/8$ SM. Aircrew may start and operate engines on the ground during forecast freezing precipitation or freezing fog but shall shut down engines as soon as practicable if ice is observed forming on the B-52 engine inlets.

8.1.4.12.4.3. **(Added-MINOTAFB)** Under both circumstances, aircrew will check for engine auxiliary air inlet icing in conjunction with anti-ice engine run requirements. Aircrew will brief crew chiefs to look for induction or aircraft icing since they may have the best view and can conduct tactile checks of aircraft surfaces. Unless operational urgency dictates, aircrew should not taxi until conditions allow for takeoff so crew chiefs can best monitor potential ice buildup.

8.1.4.12.5. **(Added-MINOTAFB)** Cold Weather Taxiing.

8.1.4.12.5.1. **(Added-MINOTAFB)** Aircrew may receive updates on status of airfield snow removal and aircraft deicing operations from FOXTROT.

8.1.4.12.5.2. **(Added-MINOTAFB)** When runway or taxiway RCR is less than 8, CHARLIE approval is required to taxi, takeoff or land. When there is any doubt about actual surface conditions or taxiway and/or runway conditions are deemed too hazardous, aircrew will terminate aircraft movement.

8.1.4.12.5.3. **(Added-MINOTAFB)** Airfield management may assign RCR values for each third of the runway (approach, mid, departure) during low RCR conditions. These values are for advisory purposes. Aircrew will only use “overall” surface condition readings and RCRs for aircraft operations (e.g. LSR 12).

8.1.4.12.6. **(Added-MINOTAFB)** Pre-Takeoff Checks.

8.1.4.12.6.1. **(Added-MINOTAFB)** See 1B-52H-1 “Snow and Ice Removal” for pre-takeoff checks. Accomplish the following checks requiring inspection from the outside of the airplane:

8.1.4.12.6.1.1. **(Added-MINOTAFB)** Advise ATC of end of runway (EOR) check. Consider doing an engine anti-ice run prior to starting the check.

8.1.4.12.6.1.2. **(Added-MINOTAFB)** The SOF is the primary to complete the EOR check utilizing the SOF vehicle. Secondary options include a designated crew member, formation member or 5 BW Flight Safety Officer.

8.1.4.12.6.1.3. **(Added-MINOTAFB)** Confirm the parking brake is set and the radar is down.

8.1.4.12.6.2. **(Added-MINOTAFB)** Upon satisfactory completion of the pre-takeoff check, takeoff as soon as practicable. If the check reveals unacceptable levels of icing coordinate with BOMBER/HAWK 1 on 321.0 for additional de-icing in the EOR.

8.1.5. Instrument Procedures

8.1.6. Weapons Employment

8.1.6.1. **(Added-MINOTAFB)** HE/Inert Weapon Releases

8.1.6.1.1. **(Added-MINOTAFB)** Aircrew will thoroughly brief range/low level (LL) route, weapon delivery, and abort/hung weapon procedures during sortie study.

8.1.6.1.2. **(Added-MINOTAFB)** A qualified Mission Lead (ML) must approve the target card prior to use.

8.1.6.1.3. **(Added-MINOTAFB)** Aircrew accomplishing the same weapon/mission activity on consecutive days (i.e., MP-F sorties) do not require an additional target study, provided there are no changes to the crew or previously briefed information.

8.1.6.1.4. **(Added-MINOTAFB)** See [Attachment 11](#) Weapons Flow Chart.

8.1.6.2. **(Added-MINOTAFB)** HE/Inert Weapon Recovery Procedures

8.1.6.2.1. **(Added-MINOTAFB)** See Runway Sweep Procedures

8.1.6.2.2. **(Added-MINOTAFB)** For multiple aircraft returning after HE/inert weapons releases, coordinate with the SOF to ensure landings are staggered and allow enough time for EOR checks.

8.1.6.2.3. (Added-MINOTAFB) Retained Weapon Recovery Procedures

8.1.6.2.3.1. (Added-MINOTAFB) Sorties returning with retained weapons will inform 5 BW/CP. Declaring an IFE is not required.

8.1.6.2.3.2. (Added-MINOTAFB) See HE/Inert Weapon EOR Procedures.

8.1.6.2.3.3. (Added-MINOTAFB) After engine shutdown and before applying external power, weapons personnel will meet the aircraft to pin the weapons. Do not allow any personnel to enter the bomb bay when power is applied to the aircraft.

8.1.6.2.4. (Added-MINOTAFB) Hung Weapon Recovery Procedures

8.1.6.2.4.1. (Added-MINOTAFB) Sorties returning with hung weapons will inform 5 BW/CP and SOF as soon as practicable. Aircrew will provide the following information: number, type, and location of hung and whether or not a visual confirmation was made. 5 BW/CP will notify the Maintenance Operations Center (MOC) and Explosive Ordnance Disposal (EOD).

8.1.6.2.4.2. (Added-MINOTAFB) Aircrew will declare an IFE and perform a straight-in approach to the runway in use.

8.1.6.2.4.3. (Added-MINOTAFB) See HE/Inert Weapon EOR Procedures.

8.1.6.2.4.4. (Added-MINOTAFB) If required to jettison external stores, the external stores jettison area is MIB 309/015 heading 170 @ 240 KIAS with altitude assigned by ATC.

8.1.6.2.4.5. (Added-MINOTAFB) See Minot AFB Instruction (MAFBI) 13-250, Airfield Operations and Base Flying Procedures for additional information on hung weapons procedures and stores jettison.

8.1.6.2.5. (Added-MINOTAFB) HE/Inert Weapon EOR Procedures

8.1.6.2.5.1. (Added-MINOTAFB) AMXS will conduct EOR check on return of all sorties that carry weapons (HE/inert) regardless of indications (i.e. clean, retained or hung).

8.1.6.2.5.2. (Added-MINOTAFB) Clear the active runway at the end (Alpha or Delta) and enter the respective hammerhead. Wait for the maintenance production supervisor to establish radio contact on 321.0. Once the AC confirms the brakes are set and radar is down, the ground weapons check team will chock the aircraft and establish ground communication. DO NOT open bomb bay doors. Weapons personnel will visually inspect the aircraft to ensure all weapons are released or that retained weapons are secure. For internal munitions, weapons personnel will look through the aft wheel well catwalk door to ensure no weapons are on the doors or hanging unsecured (i.e. by one lug).

8.1.6.2.5.3. (Added-MINOTAFB) If the weapons are released (aircraft is clean) or the retained weapons are secure, the crew chief will inform the AC the aircraft is safe to taxi back to parking. Once personnel are clear of the aircraft, taxi to park and leave bomb bay doors closed if internal weapons were carried.

8.1.6.2.5.4. **(Added-MINOTAFB)** Weapons personnel will attempt to pin hung weapons. If the pinned weapons are deemed to be in a safe configuration the IFE should be terminated and the AC may taxi back to parking.

8.1.6.2.5.5. **(Added-MINOTAFB)** If an unsafe condition is discovered (i.e. unsecure weapon, unsafe weapon, or hung weapon that cannot be pinned) the weapons team chief will immediately notify the AC. The AC will not taxi and will shut down and egress the aircraft.

8.1.6.2.6. **(Added-MINOTAFB)** Runway Sweep Procedures

8.1.6.2.6.1. **(Added-MINOTAFB)** A runway sweep is required for all sorties returning after an attempted release (successful or not) of any external lanyard-type weapon regardless of status.

8.1.6.2.6.2. **(Added-MINOTAFB)** For aircraft with clean indications (no retained, hung or unconfirmed hung external weapons) that plan touch and go's, a sweep is required following the first touch and go.

8.1.6.2.6.3. **(Added-MINOTAFB)** Runway sweeps are not required after low approaches or aircraft that had only internal weapons.

8.1.6.2.7. **(Added-MINOTAFB)** HE/Inert Weapon Debrief, Analysis, and Review

8.1.6.2.7.1. **(Added-MINOTAFB)** After releasing weapons, MLs will debrief all weapon scores. At a minimum, the debrief will include an analysis of hit criteria and aircrew-controlled factors that contributed to hit accuracy and timing.

8.1.6.2.7.2. **(Added-MINOTAFB)** AF 4037s will be submitted by the Radar Navigator (RN) with post-mission paperwork for all unusual occurrences, suspected malfunctions, or no-spots to their Squadron Weapons and Tactics, who will submit the squadron's Forms 4037 to the Wing Weapons Officer (WWO). RNs will provide a detailed explanation of all events leading up to release on the reverse side of the form in the crew narrative block (e.g., "GPS INU ground alignment, EGC/EIA, stable platform, good aiming on all offsets, zero FCI deflection at release). RNs employing unreliable weapons or maintenance problems will provide further information as requested by the WWO or to a maintenance specialist for review.

8.1.7. NVG Procedures

8.1.7. **(MINOTAFB)** NVG / Aircrew Flight Equipment (AFE) Procedures

8.1.7.1. **(Added-MINOTAFB)** NVG Procedures. Any qualified aircrew desiring to accomplish NVG training will advise AFE during mission planning to allow sufficient time for pre-flight actions. Upon return, place NVGs on post-flight shelf located in AFE.

8.1.7.2. **(Added-MINOTAFB)** Survival Vest Procedures. Carry and wear of the survival vest is optional for training sorties inside the Continental United States (CONUS). Carry of the vest is mandatory (wear optional) for missions outside of the Continental United States (OCONUS) and sorties with significant time over open water/ocean, including those over the Atlantic, Pacific, or Gulf of Mexico. Wear is mandatory for combat sorties from start countermeasures (SCM) to terminate countermeasures (TCM).

8.1.7.3. (Added-MINOTAFB) Laser Eye Protection (LEP) Procedures.

8.1.7.3.1. (Added-MINOTAFB) Each pilot scheduled to fly while employing the combat laser will check out LEP from AFE. Upon return, each pilot will place the LEP under their respective helmet on post-flight shelf located in AFE. Targeting pod sorties utilizing the training laser only do not require the use of LEP.

8.1.7.3.2. (Added-MINOTAFB) LEP wear is IAW the guidelines established in AFMAN 11-214, Air Operations Rules and Procedures, and AFMAN 11-301v1 Aircrew Flight Equipment (AFE) Program.

8.1.8. Abnormal Operating Procedure.

8.1.8. (MINOTAFB) **Abnormal Operating Procedure.** Aircrew will respond to aircraft malfunctions or anomalies with actions IAW aircraft T.O.s, directives, or those directed by the DIP with CHARLIE approval. Aircrew may assist maintenance personnel during troubleshooting procedures provided those actions are IAW aircraft T.Os.

8.1.8.1. (Added-MINOTAFB) In-Flight Emergencies.

8.1.8.1.1. (Added-MINOTAFB) See AFMAN 11-2B-52v3 for general guidance on in-flight emergencies.

8.1.8.1.2. (Added-MINOTAFB) ACs are the final authority for decisions affecting the safety of the aircraft. Unless time critical, IFE aircraft will request CHARLIE approval to penetrate. Relay request through FOXTROT and ensures proper coordination with emergency services is complete. After landing, CHIEF 1, acting as the incident commander (IC), will terminate the IFE.

8.1.8.1.3. (Added-MINOTAFB) As necessary, the DIP will provide aircrew with performance/landing data, weather/divert factors, a sanity check of aircrew's proposed course of action, and advice to aid aircraft recovery.

8.1.8.1.4. (Added-MINOTAFB) CONFERENCE HOTEL. Refer to AFI 11-418, Operations Supervision, and AFI 11-418 MAFBSUP for expanded CONFERENCE HOTEL information and procedures.

8.1.8.1.4.1. (Added-MINOTAFB) CONFERENCE HOTELS are a means to make aircraft specialists available to operations personnel to pose system-related questions that cannot be answered locally.

8.1.8.1.4.2. (Added-MINOTAFB) CONFERENCE HOTELS are hosted by 5BW/CP and include, but not limited to, the following personnel: CHARLIE, CHIEF 2, ICEMAN, FOXTROT and BOMBER/HAWK 1. As the situation dictates, the 5 BW/CC, 5 BW/CD, EOD, civilian aircraft specialists, highly experienced crew members and various other personnel may also provide input.

8.1.8.1.5. (Added-MINOTAFB) Controlled Bailout Area. The controlled bailout area is a 4 NM long by 2 NM wide area outbound on the Deering TACAN 245 radial starting at 4 DME. See MAFBI 13-250, Airfield Operations and Base Flying Procedures, for information/depiction of the Minot AFB Controlled Bailout Area.

8.1.8.2. (Added-MINOTAFB) Assorted Aircraft Malfunction Guidance.

8.1.8.2.1. **(Added-MINOTAFB)** Anti-Ice Malfunction. Aircrew experiencing anti-icing system malfunctions during periods of forecasted or reported MODERATE or SEVERE icing will hold outside of affected areas until conditions improve or a decision to divert is made.

8.1.8.2.2. **(Added-MINOTAFB)** Antiskid Malfunctions

8.1.8.2.2.1. **(Added-MINOTAFB)** Consider RCR, runway surface condition (RSC), drag chute failure and landing weight to determine the best course of action. For a dry runway, land no heavier than 290,000 lbs. Calculate landing weight to allow minimum braking for the available runway. Use the entire runway and drag chute to slow the aircraft.

8.1.8.2.2.2. **(Added-MINOTAFB)** Aircraft will not perform touch-and-go landings but may perform low approaches.

8.1.8.2.2.3. **(Added-MINOTAFB)** Crews may declare an emergency for dry runway conditions at their discretion but shall declare an emergency for RCRs less than 23 and all RSCs other than dry for the braking surface of the runway.

8.1.8.2.2.4. **(Added-MINOTAFB)** Coordinate with FOXTROT and BOMBER/HAWK 1 (as required) to monitor possible locked wheel or blown tire conditions during rollout. If a blown tire is suspected, do not taxi beyond the hammerhead until tires, brakes and wheels are inspected by maintenance personnel.

8.1.8.2.3. **(Added-MINOTAFB)** Bird Strike. Per the 1-B-52H-1, consider bird strikes to have caused at least secondary structural damage. Follow 1B-52H-1 Section 3 guidance for structural damage and consider early termination of the flight.

8.1.8.2.4. **(Added-MINOTAFB)** Lightning Strike/Static Discharge. Aircrew will terminate the mission for any known or suspected lightning strikes or aircraft static discharges caused by excessive static electricity buildup when flying in certain conducive environmental conditions. Follow T.O. procedures for structural damage.

8.1.8.2.5. **(Added-MINOTAFB)** Stuck Outboard Strut Bleed Valves. ACs may elect to start engines 1 & 2 or 7 & 8 with an air cart. Be aware of the loss of ability to motor an engine using another nacelle in case of ground fire in affected outboard nacelle. After landing, shut down the affected outboard engines in the hammerhead as soon as practicable IAW the T.O.

8.1.8.3. **(Added-MINOTAFB)** Divert, Returning Divert, and Off-Station Recovery Procedures.

Table 8.6. (Added-MINOTAFB) Alternate Airfield Fuel Requirements.

Airfield	Longest Runway	Distance (NM)	HDG (Mag)	ETE (H+MM)	Divert Fuel @ FL280	Divert Fuel @ FL350
^ Ellsworth (KRCA)	13-31 13497x300'	267	190	0+37	39K	38K
Offutt (KOFF)	13-31 11703x150'	496	144	1+08	47K	44K
Whiteman (KSZL)	01-19 12400x200'	673	141	1+31	54K	49K
*Tinker (KTIK)	18-36 11100x200'	798	160	1+47	59K	53K
*Barksdale (KBAD)	15-33 11758x299'	1016	151	2+16	67K	59K
†Fairchild (KSKA)	05-23 13899x150'	657	266	1+28	53K	49K
† Grand Forks (KRDR)	18-36 12351x150'	161	092	0+24	34K	34K
McConnell (KIAB)	01-19 12007x150'	672	157	1+30	54K	49K

NOTES:

^ Preferred divert base

* B-52 maintenance availability. If closed, Barksdale AFB can re-open with one hour notification.

† Emergency landing surface. Runway lights 85' both sides of centerline -- Damage to tip gear expected.

Assumptions:

Divert Fuel = total fuel in tanks needed to depart Minot AFB traffic pattern, climb to depicted altitude, and arrive over alternate airfield with 24,000 lbs.

Clean configuration (add 10% to fuel requirements when equipped with HSABs)

Subtract approximately 3,500 lbs. when diverting from MIB IAF at FL 200.

ETE & Fuels calculated at .765M

Climb computed for NRT thrust.

HDG, ETE, and fuel required are for a no wind standard day (re-compute for non-standard day or headwinds)

Distances and HDGs were calculated from MIB TACAN to alternate TACAN.

h. See Airfield Diagram and NOTAMs for hours of operation and additional information.

8.1.8.3.1. **(Added-MINOTAFB)** If weather or RCR falls below landing minima, coordinate through FOXTROT for alternate availability and OG guidance. Crews are expected to proceed to the primary divert base briefed at step unless unable or directed otherwise by the Ops Sup or CHARLIE. Notify 5 BW/CP and FOXTROT of directed divert base; include the planned fuel reserve overhead the divert base. After landing, contact the Ops Sup and 5 BW/CP with the tail number, land time, and AC's contact information. Reference the requirements in para 8.1.7.4 to ensure international treaty compliance.

- 8.1.8.3.2. **(Added-MINOTAFB)** Crews will secure all removable classified material at the divert base's CP.
- 8.1.8.3.3. **(Added-MINOTAFB)** Returning divert aircraft will obtain 5 OG/CC approval prior to launch.
- 8.1.8.4. **(Added-MINOTAFB)** New Strategic Arms Reduction Treaty (NST) Notifications.
- 8.1.8.4.1. **(Added-MINOTAFB)** If a sortie recovers at a location other than Minot AFB, the AC (or Flight Lead) will comply with the following requirements:
- 8.1.8.4.2. **(Added-MINOTAFB)** Contact 5 BW/CP within one hour of landing.
- 8.1.8.4.3. **(Added-MINOTAFB)** Notify 5 BW/CP two hours before takeoff.
- 8.1.8.4.4. **(Added-MINOTAFB)** Notify 5 BW/CP with exact takeoff time within one hour after departure.
- 8.1.8.4.5. **(Added-MINOTAFB)** No report is required if landing at the same airfield from which the aircraft departed.
- 8.1.8.4.6. **(Added-MINOTAFB)** The Ops Sup has primary responsibility for ensuring compliance with NST notifications, both locally and at deployed locations.
- 8.1.8.5. **(Added-MINOTAFB)** Landings Outside of Normal Airfield Operating Hours. Requests to schedule landings outside of normal/scheduled airfield operating hours require coordination with OSS/CC/DO via the Ops Sup prior to CHARLIE approval. Unscheduled landings outside of normal airfield operating hours require CHARLIE approval followed by coordination with OSS/CC/DO.
- 8.1.9. Classified Local Electronic Warfare Mission Guide
- 8.1.9.1. **(Added-MINOTAFB)** Location. Combat Crew Communications Flight (5 OSS/CCC) maintains the Classified EA Mission Material Binders. Binders contain the EA Handbook and additional documents deemed necessary by the Wing Electronic Warfare Officer (5 BW/EW).
- 8.1.9.2. **(Added-MINOTAFB)** Procedures. EWs will check out and carry a Classified EA Mission Materials Binder for all training and operational missions.
- 8.1.10. **(Added-MINOTAFB)** Check Flight Program
- 8.1.10.1. **(Added-MINOTAFB)** Administrative. 5 OG/OGV is the OPR.
- 8.1.10.1.1. **(Added-MINOTAFB)** The designated check flight airspace for Minot AFB is the Powder River Training Complex. The check flight portion will be flown during the first part of the sortie within the designated airspace of the base from which the flight was launched, except when the flight must be conducted under specific environmental conditions not compatible with local conditions or restrictions. EXCEPTION: If practical, accomplish Functional Check Flights (FCFs) in the immediate area of the departure base to determine aircraft airworthiness.

- 8.1.10.1.2. **(Added-MINOTAFB)** All check flight crew members will review the T.O. 1-1-300, AFI 21-101, Aircraft and Equipment Maintenance Management, (to include supplements), and applicable -6 checklists prior to flight.
- 8.1.10.1.3. **(Added-MINOTAFB)** Prior to execution, brief the check flight profile to the 5 OG/CC (or designated representative) and 5 OG/OGV check flight representative. Aircrew will receive a briefing from 5 MXG/QA explaining the purpose behind the check flight. Upon landing, ACs will provide all necessary information regarding airworthiness to ensure proper documentation.
- 8.1.10.1.4. **(Added-MINOTAFB)** Mission or training events may occur after the check flight portion is accomplished, provided the primary aircraft systems defined in T.O. 1-1-300 paragraph 4.1 are verified as functional and the aircraft is airworthy.
- 8.1.10.1.5. **(Added-MINOTAFB)** Check flights aircrew are defined by the T.O. plus any personnel designated by the OG/CC, or equivalent, as required for the mission.
- 8.1.10.2. **(Added-MINOTAFB)** Functional Check Flights
- 8.1.10.2.1. **(Added-MINOTAFB)** Conduct FCFs only by aircrew certified for FCF operations IAW with this section.
- 8.1.10.2.2. **(Added-MINOTAFB)** See AFMAN 11-2B-52v1 for program requirements.
- 8.1.10.2.3. **(Added-MINOTAFB)** Flying squadrons will nominate FCF aircrew for OG/CC approval.
- 8.1.10.2.4. **(Added-MINOTAFB)** The OPR will maintain a PEX training course for FCF approved aircrew.
- 8.1.10.2.5. **(Added-MINOTAFB)** Upon completion of the FCF training course, OGV will annotate aircrew in writing certification by the OG/CC. Upload this Memorandum for Record (MFR) to the aircrew training folder.
- 8.1.10.3. **(Added-MINOTAFB)** Operational Check Flights (OCFs)
- 8.1.10.3.1. **(Added-MINOTAFB)** Experienced Aircrew will accomplish all OCFs (minimum AC and RN). No upgrade training is required.
- 8.1.10.3.2. **(Added-MINOTAFB)** Coordinate OCF missions and crews through wing scheduling. At a minimum, brief the 5 OG/CC and approve crew members and sortie profile.

MARK D. KELLY, Lt Gen, USAF
Deputy Chief of Staff, Operations

(MINOTAFB)

JESSE W. LAMARAND, Colonel, USAF
Commander

Attachment 1**GLOSSARY OF REFERENCES AND SUPPORTING INFORMATION*****References***

JO 7610.4U, *Special Operations*, 1 September 2017

CJCSM 3212.02., *Performing Electronic Attack in the United States and Canada for Tests, Training and Exercises*, 31 December 2013

(Added-MINOTAFB) AFGSC B-52 *Ready Aircrew Program (RAP) Tasking Memorandum*, 1 October 2021

(Added-MINOTAFB) AFH 11-203v1, *Weather for Aircrews*, 11 January 2012

(Added-MINOTAFB) AFI 11-214, *Air Operations Rules and Procedures*, 7 July 2020

(Added-MINOTAFB) AFI 11-215, *Flight Manuals Program*, 24 March 2019

(Added-MINOTAFB) AFI 11-301v1, *Aircrew Flight Equipment (AFE) Program*, 9 October 2017

(Added-MINOTAFB) AFI 11-418, *MAFB_SUP, Operations Supervision*, 31 January 2020

(Added-MINOTAFB) AFI 11-418, *Operations Supervision*, 27 February 2020

(Added-MINOTAFB) AFI 21-101, *AFGSCSUP, Aircraft and Equipment Maintenance Management*, 18 January 2021

(Added-MINOTAFB) AFI 21-101_AFGSCSUP_MINOTAFBSUP, *Aircraft and Equipment Maintenance Management*, 2 April 2017

(Added-MINOTAFB) AFI 33-322, *Records Management and Information Governance Program*, 27 July 2021

(Added-MINOTAFB) AFI 91-212, *MAFBSUP, Minot AFB Local Bird/Wildlife Aircraft Strike Hazard Plan*, 25 June 2020

(Added-MINOTAFB) AFMAN 11-202v3, *AFGSCSUP, General Flight Rules*, 8 July 2019

(Added-MINOTAFB) AFMAN 11-202v3, *Flight Operations*, 9 June 2020

(Added-MINOTAFB) AFMAN 11-2B-52v1, *B-52 Aircrew Training*, 12 February 2019

AFPD 11-2, *Aircraft Rules and Procedures*, 19 January 2018

AFPD 11-4, *Aviation Service*, 1 September 2004

AFI 11-214, *Air Operations Rules and Procedures*, 14 August 2012

AFI 33-360, *Publications and Forms Management*, 1 December 2015

AFMAN 11-202 V3, *General Flight Rules*, 10 August 2016

AFMAN 11-2B-52 V1, *B-52 Aircrew Training*, 6 November 2015

AFPAM 11-216, *Air Navigation*, 28 February 2018

AFGSCI 13-520-S V2, *Bomber Nuclear Mission Preparation*, 19 August 2018

AFI 11-202 Volume 3, *General Flight Rules*, 2 October 2018

(Added-MINOTAFB) DAFI 21-101, *Aircraft and Equipment Maintenance Management*, 15 January 2020

(Added-MINOTAFB) DAFI 33-360, *Publications and Forms Management*, 30 November 2015

AFTTP 3-3.B52. *Combat Aircraft Fundamentals*, 7 December 2016

(Added-MINOTAFB) MINOTAFBI 11-250, *Airfield Operations and Base Flying Procedures*, 8 January 2014

(Added-MINOTAFB) T.O. 1-1-300, *Maintenance Operational Checks and Check Flights*, 15 March 2012

(Added-MINOTAFB) T.O. 1B-52H-1, *Flight Manual*, 12 October 2021

(Added-MINOTAFB) T.O. 1B-52H-1-1, Appendix 1 *Performance Data*, 17 March 2021

(Added-MINOTAFB) T.O. 1B-52H-34-2-1, *Aircrew Weapons Delivery Manual*, 5 August 2019

(Added-MINOTAFB) T.O. 1B-52H-6CF-1, *Acceptance and/or Functional Check Flight Procedures*, 14 February 2019

Adopted Forms

(Added-MINOTAFB) AF Form 4037, *OAS Briefing/Debriefing Analysis & Review*
AF Form 847, Recommendation for Change of Publication

(Added-MINOTAFB) AFTO Form 6, B-52 *Aircraft Refueling and Defueling Log*

(Added-MINOTAFB) AFTO Form 781A, *Maintenance Discrepancy and Work Document*

(Added-MINOTAFB) AFTO Form 781H, *Aerospace Vehicle Flight Status and Maintenance*

(Added-MINOTAFB) DD Form 1801, *DoD International Flight Plan*

DD Form 1801, *International Flight Plan*

(Added-MINOTAFB) Form F, *Weight and Balance Clearance Form*

Abbreviations and Acronyms

(Added-MINOTAFB) AC—Aircraft Commander

(Added-MINOTAFB) ACN—Aircraft Classification Number

(Added-MINOTAFB) AFB—Air Force Base

(Added-MINOTAFB) AFE—Aircrew Flight Equipment

(Added-MINOTAFB) AFGSC—Air Force Global Strike Command

(Added-MINOTAFB) AFH—Air Force Handbook

(Added-MINOTAFB) AFI—Air Force Instruction

(Added-MINOTAFB) AFMAN—Air Force Manual

(Added-MINOTAFB) AFRIMS—Air Force Records Information Management System

(Added-MINOTAFB) AFTO—Air Force Technical Order

AFTTP—Air Force Tactics, Techniques, and Procedures

ADI—Attitude Direction Indicator

AGL—Above Ground Level

(Added-MINOTAFB) AHAS—Avian Hazard Advisory System

AHRS—Attitude and Heading Reference System

AIU—Armament Interface Unit

(Added-MINOTAFB) APA—Alternate Parking Apron

ARDA—Airborne Radar Directed Approach

ASL—Above Sea Level

ALTRV—Altitude Reservation

AOC—Air Operations Center

ARTCC—Air Route Traffic Control Centers

(Added-MINOTAFB) ASLO—Air Show Liaison Officer

ATC—Air Traffic Control

(Added-MINOTAFB) ATCAA—Air Traffic Control Assigned Airspace

ATD—Aircrew Training Device

ATO—Air Tasking Order

BAM—Bird Avoidance Model

(Added-MINOTAFB) BASH—Bird/Wildlife Aircraft Strike Hazard

(Added-MINOTAFB) BW—Bomb Wing

(Added-MINOTAFB) BWC—Bird Watch Condition

CHUM—Chart Update Manual

(Added-MINOTAFB) CONUS—Continental United States

(Added-MINOTAFB) CP—Command Post

CRL—Conventional Rotary Launcher

CSRL—Cruise Missile Rotary Launcher

DAFIF—Digital Aeronautical Flight Information File

DBRIC—Digital Bomb Release Interval Controller

DH—Decision Height

(Added-MINOTAFB) DIP—Duty Instructor Pilot

(Added-MINOTAFB) DME—Distance Measuring Equipment
(Added-MINOTAFB) DTC—Data Transfer Cartridge
(Added-MINOTAFB) EA—Electronic Attack
(Added-MINOTAFB) EEP—East Entry Point
(Added-MINOTAFB) EFB—Electronic Flight Bag
(Added-MINOTAFB) EGC—Enhanced Gyrocompass Mode
(Added-MINOTAFB) EIA—Enhanced Interrupted Alignment
EMCON—Emission Control
(Added-MINOTAFB) EOD—Explosive Ordnance Disposal
(Added-MINOTAFB) EOR—End of Runway
(Added-MINOTAFB) ERCC—Engine Running Crew Change
(Added-MINOTAFB) ETE—Estimated Time En route
(Added-MINOTAFB) EW—Electronic Warfare
EWO—Electronic Warfare Officer
EXORD—Execution Order
FAC—Forward Air Controller
FAAH—Federal Aviation Administration Handbook
FAF—Final Approach Fix
(Added-MINOTAFB) FCF—Functional Check Flight
(Added-MINOTAFB) FCI—Flight Command Indicator
(Added-MINOTAFB) FCIF—Flight Crew Information
FIC—Flight Instructor Course
FIE—Fighter Intercept Exercise
(Added-MINOTAFB) FIH—Flight Information Handbook
FLIP—Flight Information Program
(Added-MINOTAFB) FLIP—Flight Information Publication
(Added-MINOTAFB) FMP—Flight Manuals Program
(Added-MINOTAFB) FOD—Foreign Object Debris
(Added-MINOTAFB) GPS—Global Positioning System
HAT—Height Above Touchdown
(Added-MINOTAFB) HDG—Heading
HE—High Explosive

HHD—Higher Headquarters Directed

HF—High Frequency

(Added-MINOTAFB) HOT—Holdover Time

(Added-MINOTAFB) HSAB—Heavy Stores Adapter Beam

IAF—Initial Approach Fix

IAW—In Accordance With

(Added-MINOTAFB) IC—Incident Commander

IFF—Identification Friend or Foe

IFE—Inflight Emergency

INU—Inertial Navigation Unit

IMC—Instrument Meteorological Conditions

INS—Inertial Navigation System

(Added-MINOTAFB) IOAT—Indicated Outside Air Temperature

IP—Instructor Pilot

IR—IFR Military Training Route

JTAC—Joint Tactical Air Controller

(Added-MINOTAFB) KIAS—Knots Indicated Airspeed

(Added-MINOTAFB) LEP—Laser Eye Protection

(Added-MINOTAFB) LL—Low Level

(Added-MINOTAFB) LOA—Letter of Agreement

(Added-MINOTAFB) LOUT—Lowest Operational Use Temperature

LOWAT—Low Altitude

(Added-MINOTAFB) MAFBI—Minot Air Force Base Instruction

(Added-MINOTAFB) MAFBSUP—Minot Air Force Base Supplement

(Added-MINOTAFB) MAJCOM—Major Command

MALD—Miniature Air Launched Decoy

(Added-MINOTAFB) MAR—Mission Accomplishment Report

MARSA—Military Assumes Responsibility for Separation of Aircraft

MAP—Missed Approach Point

(Added-MINOTAFB) MC—Magnetic Course

MDA—Minimum Descent Altitude

MFD—Multi-Functional Display

(Added-MINOTAFB) MFR—Memorandum for Record
MIU—Missile Interface Unit
(Added-MINOTAFB) ML—Mission Lead
(Added-MINOTAFB) MOC—Maintenance Operations Center
(Added-MINOTAFB) MOU—Memorandum of Understanding
(Added-MINOTAFB) MPA—Mass Parking Apron
MPC—Mission Planning Cell
(Added-MINOTAFB) MP-F—Mission Plan-Fly
MSA—Minimum Sector Altitude
(Added-MINOTAFB) MSL—Mean Sea Level
MTR—Military Training Route
(Added-MINOTAFB) NAF—Numbered Air Force
(Added-MINOTAFB) NLT—No Later Than
NM—Nautical Miles
(Added-MINOTAFB) NOTAM—Notices to Airmen
(Added-MINOTAFB) NRT—Normal Rated Thrust
(Added-MINOTAFB) NST—New Strategic Arms Reduction Treaty
NVG—Night Vision Goggles
OAS—Offensive Avionics System
(Added-MINOTAFB) OAT—Outside Air Temperature
(Added-MINOTAFB) OCF—Operational Check Flight
(Added-MINOTAFB) OCONUS—Outside the Continental United States
ORM—Operational Risk Management
OPR—Office of Primary Responsibility
ORI—Operational Readiness Inspection
(Added-MINOTAFB) OSTF—Off-Station Training Flights
(Added-MINOTAFB) OTS—Off the Shelf
(Added-MINOTAFB) PIREP—Pilot Report
(Added-MINOTAFB) PMSV—Pilot Meteorological Service
(Added-MINOTAFB) POC—Point of Contact
(Added-MINOTAFB) PPE—Personal Protective Equipment
(Added-MINOTAFB) PPS—Pilot Proficiency Sortie

PTOB—Pre-Takeoff Brief

(Added-MINOTAFB) PTOB—Pre-Takeoff Briefing

(Added-MINOTAFB) RAP—Ready Aircrew Program

RCD—Release Circuits Disconnect

RCR—Runway Condition Reading

RCO—Range Control Officer

(Added-MINOTAFB) RDS—Records Disposition Schedule

RIU—Radar Interface Unit

RN—Radar Navigator

RNAV—Area Navigation

RNP—Required Navigation Performance

(Added-MINOTAFB) RSC—Runway Surface Condition

(Added-MINOTAFB) RSD—Removable Storage Device

(Added-MINOTAFB) RVSM—Reduced Vertical Separation Minima

(Added-MINOTAFB) SCM—Start Countermeasures

SMO—Stores Management Overlay

(Added-MINOTAFB) SNG—Show and Go

SOF—Supervisor of Flying

SPINS—Special Instructions

(Added-MINOTAFB) SSS—Staff Summary Sheet

(Added-MINOTAFB) TACAN—Tactical Air Navigation System

(Added-MINOTAFB) TAR—Training Activity Report

(Added-MINOTAFB) TC—Team Chief

(Added-MINOTAFB) TCM—Terminate Countermeasures

(Added-MINOTAFB) TDY—Temporary Duty

TDZ—Touchdown Zone

TERPs—Terminal Instrument Procedures

TGP—Targeting Pod

(Added-MINOTAFB) TO—Technical Order

(Added-MINOTAFB) TODA—Technical Order Distribution Alternate

(Added-MINOTAFB) TODO—Technical Order Distribution Officer

(Added-MINOTAFB) TOLD—Takeoff and Landing Data

UHF—Ultra High Frequency

VASI—Visual Approach Slope Indicator

VFR—Visual Flight Rules

VMC—Visual Meteorological Conditions

VR—VFR Military Training Route

(Added-MINOTAFB) WEP—West Entry Point

WIU—Weapons Interface Unit

WSO—Weapons System Operator

WST—Weapon System Trainer

Terms

(Added-MINOTAFB) Accountable Forms—Forms that the Air Force stringently controls, and which cannot be released to unauthorized personnel, since their misuse could jeopardize DOD security or result in fraudulent financial gain or claims against the government.

(Added-MINOTAFB) Administrative Change—Change that does not affect the subject matter content, authority, purpose, application, and/or implementation of the publication (e.g., changing the POC name, office symbol(s), fixing misspellings, etc.)

Air Traffic Control—The agency or agencies providing flight services and control for aircraft operations. This includes FAA authorities in the US, equivalent international agencies, and tactical control agencies (AWACS, etc) that provide clearances, separation, advisories, etc. If foreign or tactical equivalents do not provide services in a given area, requirements to coordinate with ATC are lifted and aircrew may continue IAW sound ORM.

(Added-MINOTAFB) Approval Authority—Senior leader responsible for contributing to and implementing policies and guidance/procedures pertaining to his/her functional area(s) (e.g., heads of functional two-letter offices).

Attempted Release—Aircrew have properly configured for release (or jettison) and the bombing system has issued a release pulse or command.

(Added-MINOTAFB) Authentication—Required element to verify approval of the publication; the approval official applies his/her signature block to authenticate the publication. The signature block includes the official's name, rank, and title (not signature).

Critical Phases of Flight—See AFI 11-202 Vol 3.

Mission Employment Area—Areas used to conduct training in weapons employment, tactics, low altitude navigation, threat avoidance, intercepts, and other areas directly related to B-52 employment. These areas include, but are not limited to, IR and VR routes, MOAs, ranges, and Restricted/Warning Areas.

Range Control Officer (RCO)—RCO or other range control personnel qualified to issue release clearance, confirm weapon release, or authorize use of jettison/salvo areas.

Route Width (Route Perimeter)—the route boundary limits within which aircraft are restricted to conduct operations.

Safe Clearance Altitude (SCA)—A minimum ‘hard’ MSL altitude for low-level operations, determined by applying the appropriate buffer to terrain/obstacles encountered on a route or area segment, flown by reference to the altimeter; as opposed to flying by TA procedures or attempting to hold an AGL altitude via the radar altimeter.

Attachment 2

LOW-LEVEL OPERATIONS ON MILITARY TRAINING ROUTES

A2.1. General. The guidance below is additive to the guidance given in **Chapter 3** and addresses procedures and restrictions specific to fly low-level routes defined by FLIP AP1/B (MTRs/IRs/VRs). MTRs may be IFR routes (denoted by IR and a four digit identifier) or Visual (denoted by VR and a three digit identifier). Crews will reference this attachment prior to flying such routes. (T-3).

A2.1.1. Altitude. IR routes are designed to be flown under IFR regardless of weather and all route segments are 1,500 AGL or above. VR have segments from the surface to 1500 AGL. B-52 Safe Clearance Altitudes (SCA), regardless of operating on an IR or VR, will be at least 1000 feet above (2000 in mountainous terrain as defined by the FAA in domestic airspace, host nation, or special instructions) the highest elevation or obstacle within 4 NM of the planned route, or the minimum altitude defined by the MTR, whichever is higher.

A2.1.2. B-52 crews will fly Military Training Routes at 360 knots ground speed unless mission requirements dictate otherwise. (T-3).

A2.2. Communications.

A2.2.1. Prior to entering an IFR Military Training Route (IR), confirm with ARTCC the entry and exit fix time, the requested altitude after exiting, and if applicable, the number of reentries. (T-3).

A2.2.2. Refer to Flight Information Publication (FLIP) AP/1B, *Area Planning - Military Training Routes*, for communications procedures on VFR Routes (VRs).

A2.2.3. During low-level, monitor Flight Service Station (FSS) for Significant Meteorological Information (SIGMET) and Airmen Meteorological Information (AIRMET) advisories at all times except at reporting/monitoring points, on the bomb run, when in contact with ARTCC, or when inflight priorities dictate otherwise. (T-3).

A2.2.4. Communications Failure on an IR Route. When flying a route without a published communications failure altitude, file the communications failure altitude in the remarks section of the DD Form 1801 and confirm with ATC prior to entry. (T-3).

A2.3. Weather Requirements.

A2.3.1. Visibility/Cloud Clearance Requirements. Abort the low-level route if unable to maintain FLIP AP-1B weather minima for the route. (T-0).

A2.3.2. Obtain updated weather within 30 minutes of route entry. (T-3).

A2.3.3. Use all available information to evaluate the possibility of encountering mountain wave effects. If it appears mountain wave effects could be encountered, climb to Minimum Safe Altitude (MSA) or IFR altitude early enough to avoid the effects. If mountain wave effects are encountered at any altitude, abort the area. (T-3).

A2.3.4. Aircrew will abort the low-level when notified of route/area closure if they have not passed the area of hazardous weather or flight conditions. If the aircrew is advised the route is closed after passing through the area of hazardous weather, the decision to continue or abort rests with the crew. Aircrews aborting a mission employment area due to hazardous weather or flight conditions should advise the home station command post and provide a Pilot Report (PIREP) of observed conditions. (T-3).

A2.4. Negative Altitude Variations. Aircrews will use altitude variations from PMSV (or compute using PMSV altimeter settings and D values) to determine which route segments are affected by excessive altitude variations. This information should be obtained as close as possible to the planned entry time. Crews unable to contact a PMSV station may enter using information from the preflight weather briefing.

A2.4.1. If any of the following situations occur during Instrument Meteorological Conditions (IMC) or at night, and the crew is unable to clear terrain visually, abort the route (NVGs may be used to clear terrain visually during night Visual Meteorological Conditions (VMC)):

A2.4.1.1. The difference between aircraft pressure altitude as indicated with the most current altimeter setting and the Offensive Avionics System (OAS)/Absolute Altitude (HA) computed true altitude exceeds -400 feet. This can be measured directly by taking an altitude calibration (for example, a 2420 Mean Sea Level (MSL) pressure altimeter reading and a 2000 feet OAS/ HA value would yield a -420 feet altitude variation).

A2.4.1.2. The aircraft radar altimeter indicates less than a 600 feet terrain crossing while at the MSA/IFR altitude.

A2.4.1.2.1. IR-800, points F to T: -600.

A2.4.1.2.2. IR-800, points AL to AX and AX to AS for racetrack routing: -600 feet.

A2.4.1.2.3. IR-801, points A to AL: Unlimited.

A2.4.2. When only the entry point area is forecast with excessive altitude variation, the crew may enter the route even with IMC conditions at the entry point. However, the crew cannot descend below 1000 feet above the IFR/MSA altitude for the route without entering and maintaining VMC. (T-3).

A2.4.3. When latter portions of the low-level route are forecast with excessive altitude variation and the entry point is within prescribed tolerances, crews may enter the route in IMC conditions and fly MSA/IFR altitude up to the area of excessive altitude variation. Prior to entering the area of excessive altitude variation, crews must be able to visually clear terrain in order to continue low-level operations. Once the forecast/observed area(s) of excessive altitude variation is overflown, subsequent portions of the low-level route may be flown.

A2.5. IR Route Timing Tolerances. Crews will use the timing tolerances as specified in FLIP AP/1B. In the absence of specified requirements, aircrew will enter only at scheduled time plus or minus 5 minutes. If the scheduled entry cannot be made within the above tolerance, the use of subsequent primary or alternate entry points/times is authorized provided the aircrew has been so briefed and will maintain route timing.

A2.6. VR Route Procedures. All flights on VRs will be conducted IAW AFI 11- 202 Vol 3. If FLIP AP/1B weather minimums cannot be maintained, the aircraft will abort the route. Aircraft will enter VRs only at designated route points. Exit only at designated route points unless weather conditions or an emergency situation dictates otherwise. (T-0).

A2.7. Route Deviation. If ATC issues instructions that cause the aircraft to deviate outside the route width or altitude structure (IRs or VRs), the aircrew may continue the mission provided the following conditions are met:

A2.7.1. ATC controllers can ensure positive radar surveillance until the aircraft is established back in the route structure.

A2.7.2. Mission timing tolerance can be met at the next low-level navigation point.

A2.8. Abort Procedures. Crews aborting low-level will obtain clearance from ATC prior to departing the low-level unless a safety of flight condition (turbulence, thunderstorms, equipment malfunctions, etc.) exists which necessitates an immediate climb or turn. If aborting without a clearance, climb to a safe altitude on a course which will avoid airways and Class A, B, C, and D controlled airspace when possible. In addition, aircrew aborting without a clearance will place the IFF to emergency setting, report the emergency and flight plan deviation as soon as possible and obtain a new clearance. If required to fly without an IFR clearance, cruise at appropriate VFR altitudes until IFR clearance is received. (T-2).

A2.9. Formation Low-Level.

A2.9.1. Prior to Descent to Low-level. Normally obtain low-level en route spacing, with ARTCC clearance, at high altitude prior to the entry point. If not obtained prior to entry, spacing for the low-level route may be acquired after all aircraft have entered the route structure by using airspeed differential or "S" turns within the corridor at the aircrew's discretion.

A2.9.2. Spacing for Degraded Aircraft Performance. If any aircraft has degraded performance (gear down, air refueling door open, etc.) to the extent they cannot meet formation time tolerances, but can meet published time tolerances, place that aircraft at the end of the formation before low-level entry. There can be no more than one degraded aircraft per low-level formation in IMC.

A2.9.3. Low-level En route.

A2.9.3.1. Spacing. Maintain low-level en route spacing by precise time control at each low-level action point. Reference AFTTP 3-3.B-52 for specific procedures.

A2.9.3.2. Altitude. All aircraft should plan to fly the same altitude schedule (SCA or MSA/IFR altitude) during low-level formation operations. Flight lead will direct formation to climb to MSA/IFR altitude prior to entering instrument conditions. If in instrument conditions, all aircraft will level off and fly MSA/IFR altitudes and maintain briefed timing separation for spacing. (T-3).

A2.9.3.3. Navigation:

- A2.9.3.3.1. If visual, maximize EMCON procedures. Each aircraft will fly autonomously and need not be in trail of preceding aircraft. Terrain masking ground track may be different for each aircraft within the formation. Each crew must be constantly aware of the position of all other aircraft in the formation. Maintain appropriate spacing.
- A2.9.3.3.2. Before flight, mission lead must brief en route threats, tactical considerations, update points, terrain masking plan, EMCON procedures, and visual or instrument procedures. Note: If conducting tactical maneuver training during en route navigation, it should take place in all aircraft. Turns in excess of 90 degrees heading change offer the potential for spacing conflicts when flight lead masks to the outside of a turn point and following aircraft masks to the inside. All aircraft must work from the same tactical scenario. Additionally, all aircraft should maneuver in response to threat signal activity.
- A2.9.3.4. Airspeed. Control airspeed to meet low-level action points within briefed timing tolerances. Bomb run airspeeds will ensure time on target and weapons release parameters are met.
- A2.9.4. Abort Procedures. Refer to [paragraph 3.3.9](#) for additional procedures.
- A2.9.4.1. Individual Aircraft. If an individual aircraft aborts during low-level, immediately notify the formation and follow appropriate procedures. Absent overriding tactical considerations, all aircraft in the formation will place radars and air-to-air TACAN to operate/on. The aborting aircraft will clear the formation and notify them of intentions. Aborting aircraft have priority over all other activity.
- A2.9.4.2. Aborting as a Formation. If the entire formation must abort the low-level route, follow appropriate procedures as defined in AFTTP 3-3.B-52. Additionally, absent overriding tactical considerations, all aircraft will immediately establish radio contact while placing appropriate radars and air-to-air TACAN to operate/on. Flight lead will direct altitude separation, headings, and airspeeds. Establish positive radar and/or visual contact before the formation performs any climbing maneuver other than to establish immediate altitude separation and maintain a safe terrain clearance. Establish abort routing, altitude, and procedures during the formation briefing. (T-3).
- A2.9.4.3. In instrument conditions, if an aircraft cannot assure positive separation from other aircraft or is unable to maintain formation, immediately initiate a climb out of the low-level route and follow lost wingman procedures. (T-3)

Attachment 3

STRANGE FIELD FAMILIARIZATION

A3.1. Procedures for Flights into Strange Airfields. The following procedures aid in the preparation for flights into strange airfields. This outline is a guide and crewmembers should review only the information that is appropriate to their mission (for example, load bearing capacity need not be reviewed for flights into airfields with similar aircraft).

A3.1.1. Crews should review the following information for each base of intended landing:

A3.1.1.1. FLIP Enroute Supplement:

A3.1.1.1.1. Traffic pattern/special practices

A3.1.1.1.2. Nav aids maintenance periods

A3.1.1.1.3. Facilities/services available

A3.1.1.1.4. Load bearing capacity

A3.1.1.2. FLIP Planning Documents:

A3.1.1.2.1. Special notices

A3.1.1.2.2. Preferred routing

A3.1.1.2.3. Terminal Control Areas

A3.1.1.2.4. International Civil Aviation Organization (ICAO) information

A3.1.1.3. Approach Plates:

A3.1.1.3.1. Airfield layout/obstacles/runway length and width

A3.1.1.3.2. Final approach runway alignment

A3.1.1.3.3. Airfield lighting

A3.1.1.3.4. Navigation chart (review for local terrain features and ARDA considerations)

A3.1.2. Before departure from each base, crews may use the following guide as a means of reviewing the arrival/approach procedures for the next intended landing base:

A3.1.2.1. Departure:

A3.1.2.1.1. Obstacles

A3.1.2.1.2. Rate of climb required

A3.1.2.1.3. Emergency/minimum safe altitudes

A3.1.2.1.4. Routing/nav aids/altitude restrictions

A3.1.2.2. Enroute Descent:

A3.1.2.2.1. Start descent point

A3.1.2.2.2. Rate of descent required

A3.1.2.2.3. Transition altitude

- A3.1.2.2.4. Terminal fix (IAF, FAF, Procedures turn fix, PAR, etc.)
- A3.1.2.2.5. Lost communications procedures
- A3.1.2.2.6. Emergency/minimum safe, sector altitudes
- A3.1.2.3. Published Penetration:
 - A3.1.2.3.1. IAF/holding fix
 - A3.1.2.3.2. Initial rate of descent required
 - A3.1.2.3.3. Transition altitude
 - A3.1.2.3.4. Altitude restrictions
 - A3.1.2.3.5. Emergency/minimum safe altitudes
 - A3.1.2.3.6. Final approach fix
 - A3.1.2.3.7. Lost communications procedures
- A3.1.2.4. Final Approach—Published or Radar:
 - A3.1.2.4.1. Rate of descent
 - A3.1.2.4.2. Timing
 - A3.1.2.4.3. Weather minimums/MDA/DH
 - A3.1.2.4.4. Missed approach procedures
 - A3.1.2.4.5. Lost communications procedures
 - A3.1.2.4.6. Transition to landing/runway environment

Attachment 4

STRATEGIC WEAPONS FERRY MISSION REQUIREMENTS

A4.1. Overview.

A4.1.1. A strategic weapons ferry mission is a peacetime operational procedure for the expedient relocation of nuclear cruise missiles, without warheads, using strategic combat aircraft. Units are encouraged and expected to use nuclear procedures to the maximum extent practicable (i.e. weapons preflight, loading, etc.), and comply with published guidance regarding in-flight training with weapons aboard.

A4.1.2. The term “tactical ferry” is a generic term for transportation of weapons and as such may be seen in nuclear cruise missile technical orders and other published guidance that applies to strategic weapons ferry missions.

A4.1.3. This directive does not apply to captive carry or other test flights conducted under Nuclear Weapon System Evaluation (NucWSEP). These test flights will be conducted IAW applicable project orders and test support plans.

A4.2. Implementation Order:

A4.2.1. A strategic weapons ferry mission (or series of missions) will be initiated with a AFGSC Implementation Order approved by the AFGSC, Director of Operations (AFGSC/A3). AFGSC/A3T will work with other staff agencies and with a point of contact (POC) in 8AF, 608 AOC, AFNWC/LG, and each unit involved to consolidate necessary information for Implementation Order preparation, and will plan to have the Implementation Order released not less than 45 days prior to first sortie. The Implementation Order will include, but is not limited to, the following information:

A4.2.1.1. Tasked units.

A4.2.1.2. Number of missiles and associated equipment to move by unit.

A4.2.1.3. Required end state of missile inventory.

A4.2.1.4. Configuration of pylons, Common Strategic Rotary Launcher (CSRL) and missiles as applicable.

A4.2.1.5. Pylon/CSRL System Interface Test/Missile Interface Test (SIT/MIT) requirements as applicable.

A4.2.1.6. Missile gain/loss documentation requirements.

A4.2.1.7. Crew qualification requirements.

A4.2.1.8. Sortie limitations.

A4.2.1.9. Coordinating instructions.

A4.2.1.10. POC for each organization.

A4.2.1.11. Funding instructions.

A4.2.1.12. Additional special instructions (SPINS) as required.

A4.2.1.13. Nuclear Weapons Related Material Transfer requirements.

A4.2.2. Implementation Order may modify or augment the directions in this manual.

A4.2.3. A sample Implementation Order is provided in [Figure A4.1](#) as an example.

A4.3. Crew Requirements:

A4.3.1. All crewmembers occupying primary crew positions will be RAP ready for the nuclear mission to a CMR or BMC rate (as assigned for to crew member's unit and duty assignment), IAW most recent AFGSC B-52 Ready Aircrew Program (RAP) Tasking Message.

A4.3.2. Strategic weapon(s) ferry missions must be flown by a full combat crew. The waiver authority for this requirement is AFGSC/A3.

A4.4. Crew Training:

A4.4.1. Crews assigned to strategic weapon(s) ferry sorties will conduct mission planning as a complete crew within 72 hours of mission execution. All crewmembers will review the following topics prior to each strategic weapon(s) ferry sortie during mission planning.

A4.4.1.1. Implementation Order Review: Briefing given by a wing POC for ferry operations with emphasis on items applicable to crewmembers, i.e. SPINS, sortie limitations, crew qualification requirements and aircraft configuration.

A4.4.1.2. Weather requirements.

A4.4.1.3. Divert procedures with emphasis on weapons security requirements at divert base.

A4.4.1.4. Fuel planning, to include ballast, air refueling and divert fuel.

A4.4.1.5. Fuel panel operations for applicable weapon load.

A4.4.1.6. Take off and heavy weight landings with applicable weapon load.

A4.4.1.7. Flight restrictions specific to a ferry mission.

A4.4.1.8. Emergency jettison: single missile, multiple missile and pylon as applicable.

A4.4.1.9. Center of gravity considerations, specifically fuel and jettison effects.

A4.4.1.10. Weapons preflight

A4.4.1.11. Operational Risk Management (ORM) Plan Review. Crew specific items as outlined in [paragraph A4.5.1](#) of this document.

A4.5. Operational Risk Management (ORM) Plan.

A4.5.1. Tasked wings will submit an ORM plan, coordinated through 8 AF 608 AOC, to AFGSC/A3T NLT 30 days prior to first strategic weapon(s) ferry sortie. The ORM plan must address the following topics at a minimum:

A4.5.1.1. Oversight of weapon payload verification prior to departing the weapons storage area.

A4.5.1.2. Oversight of weapon payload verification prior to aircraft loading.

A4.5.1.3. Oversight of weapon payload verification by aircrew or by wing weapons officer prior to aircrew acceptance.

- A4.5.1.4. Oversight of weapon preflight procedures.
- A4.5.1.5. Tanker support.
- A4.5.1.6. Communications requirements.
- A4.5.1.7. Weather considerations.
- A4.5.1.8. Bird-Aircraft Strike Hazard (BASH).
- A4.5.1.9. Sortie Go/No-Go criteria.
- A4.5.1.10. Enroute decision points.
- A4.5.1.11. Runway condition/runway condition reading (RCR).
- A4.5.1.12. CG/ballast issues.
- A4.5.1.13. Jettison.
- A4.5.1.14. Divert.
- A4.5.1.15. Command and Control Procedures.

A4.5.2. Weapon payload verification will include a plan to ensure agreement of Launcher/Pylon and missile serial numbers with approved unit schedule and work order.

A4.5.3. Units will identify issues requiring higher headquarters assistance as early as possible to ensure timely resolution prior to the first strategic ferry sortie.

A4.6. Sortie Execution:

A4.6.1. Commanders may delay or cancel strategic weapons ferry actions if required in the interest of safety. Unanticipated higher priority tasking (e.g. treaty visit requirements) may require delay or cancellation of ferry missions.

A4.6.2. Avoid scheduling arrivals during times of heavy pattern usage, and afford ferry sorties priority to minimize delays during recovery.

A4.6.3. Units will keep AFGSC/A3T and 8AF/608 AOC informed of daily strategic ferry sortie status during execution. AFGSC/A3T will coordinate communication method with unit POC. Advise AFGSC/A3T when sorties take off and land or become delayed (if not as scheduled, explain); unexpected risks noted and action taken and provide a POC who can be contacted for further information.

Attachment 5

LOST WINGMAN PROCEDURES

A5.1. Lost Wingman Procedures. Use these procedures when visual and radar contact are lost and positive separation cannot be assured. In any lost wingman situation, immediate separation of aircraft is essential to maintain safety. Upon losing sight of and radar contact with flight lead, or if unable to maintain formation due to disorientation, the wingman will simultaneously execute the applicable lost wingman procedure, transition to instruments, and notify flight lead. Use a bank angle equal to the number of degrees to turn to achieve separation. Smooth application of control inputs is imperative to minimize the effects of spatial disorientation. Any aircraft, which can maintain visual and/or radar contact with an aircraft executing a lost wingman maneuver, will remain in formation with that aircraft until otherwise directed by flight lead. When flight lead is notified by a lost wingman, they will take appropriate action as the situation dictates until assuring positive separation. Flight lead will establish a reference heading and altitude after initial separation is assured. During recovery, if the flight has a block altitude clearance, wingmen should establish appropriate altitude separation.

A5.1.1. Two-Aircraft Flights.

A5.1.1.1. In wings level flight (climbing, descending, or level) simultaneously transition to instruments, inform flight lead, turn 15 degrees away and maintain new heading for 15 seconds, then resume course. Return to formation or obtain separate clearance if required.

A5.1.1.2. On the outside of the turn, transition to instruments, roll to wings level, and inform flight lead. Continue straight ahead to ensure separation prior to resuming turn. Return to formation if able or obtain separate clearance as required.

A5.1.1.3. On the inside of the turn, simultaneously transition to instruments and maintain established bank angle, reduce airspeed by 10 KIAS to ensure clearance, and inform flight lead. Flight lead will simultaneously roll wings level, maintain airspeed, and acknowledge the wingman's call. If flight lead has acknowledged the lost wingman call and confirms lead aircraft is wings level, the wingman will, after 15 seconds, roll wings level, establish 500 feet altitude separation, turn to lead's referenced heading and attempt to acquire flight lead on radar. If flight lead does not acknowledge, the wingman will maintain established bank angle, establish 500 feet altitude separation and roll out on a new heading. Attempt to acquire flight lead on radar and form into enroute formation position. If radar contact cannot be reestablished, obtain separate clearance from the controlling agency.

A5.1.2. Three-Aircraft Flights. If only one aircraft in the flight is separated, the procedures listed above will provide safe separation. However, as it is impossible for number three to immediately ascertain if number two still has visual or radar contact with flight lead, it is imperative that number three's initial action be based on the assumption that number two is also separated. Number two will maintain position if in visual or radar contact. If number two goes lost wingman, follow the procedures outlined above; number three will follow the procedures listed below:

A5.1.2.1. In wings level flight (climbing, descending, or level) simultaneously transition to instruments, inform flight lead, turn 30 degrees away, maintain new heading for 30 seconds, then resume course. Adjust to formation or obtain separate clearance as required

A5.1.2.2. On the outside of the turn, simultaneously transition to instruments, inform flight lead and reverse direction of turn for 15 seconds to ensure separation from flight lead and number two. Adjust to formation or obtain separate clearance as required.

A5.1.2.3. On the inside of the turn, simultaneously transition to instruments and maintain established bank angle, reduce airspeed by 20 KIAS to ensure clearance, and inform flight lead. Flight lead will simultaneously roll wings level, maintain airspeed and acknowledge the wingman's call. If flight lead acknowledges the lost wingman call and confirms wings level, establish 1,000 feet altitude separation, turn to flight lead's referenced heading, and attempt to acquire flight lead and number two on radar. If flight lead does not acknowledge loss of visual contact, maintain established bank angle, establish 1,000 feet altitude separation, roll out on new heading, attempt to acquire flight lead on radar, and form into enroute formation position. If radar contact is not reestablished, obtain separate clearance from ATC.

A5.1.3. **All Aircraft.** At night, after establishing positive separation, absent overriding tactical concerns, all aircraft will display anti-collision and position lights to aid in reestablishing contact, if applicable.

Attachment 6 (Added-MINOTAFB)**OFF-STATION TRAINING FLIGHTS AND AIR SHOWS****A6.1. (Added-MINOTAFB) Off Station Training Flights (OSTF).**

A6.1.1. **(Added-MINOTAFB)** OSTF event coordinators will complete an electronic Staff Summary Sheet (eSSS) package for coordination and approval NLT 3 weeks prior to event departure (5 weeks prior for OCONUS events). Package must contain event details, applicable waivers and FLIP airfield diagrams.

A6.1.2. **(Added-MINOTAFB)** Non-Air Show OSTFs. Aircrew may request to remain overnight at airfields under the following conditions:

A6.1.2.1. **(Added-MINOTAFB)** 5 OG/CC approval is granted.

A6.1.2.2. **(Added-MINOTAFB)** Host airfield manager approval is granted.

A6.1.2.3. **(Added-MINOTAFB)** Adequate aircraft support and security is coordinated and available.

A6.2. (Added-MINOTAFB) Air Shows.

A6.2.1. **(Added-MINOTAFB)** Air shows are OSTFs generated by a host unit or an organization's written request for static or flyover support.

A6.2.1.1. **(Added-MINOTAFB)** For all Civilian Field airshow arrivals or flyovers aircrew will utilize VHF approach and tower frequencies for deconfliction with civilian traffic.

A6.2.2. **(Added-MINOTAFB)** Air Show Liaison Officer (ASLO). SQ/DOs will appoint permanent primary and alternate ASLOs. For each request, ASLOs will perform all initial coordination functions (including Foreign Clearance Guide requirements for OCONUS) until an aircrew is officially selected for the event. ASLOs will maintain a continuity binder containing, as a minimum, example air show packages and applicable instructions.

A6.3. (Added-MINOTAFB) Waivers.

A6.3.1. **(Added-MINOTAFB)** ASLOs will ensure waivers are included as necessary in the coordination package for all events requiring such documentation.

A6.3.2. **(Added-MINOTAFB)** The 5 OG/CC is the waiver authority for runway and taxiway requirements. Waivers are required in the following instances:

A6.3.2.1. **(Added-MINOTAFB)** Runway dimensions are less than 10,000 feet long and/or 200 feet wide. Taxiway paved surface (including shoulders) is less than 175 feet wide.

A6.3.2.2. **(Added-MINOTAFB)** Planned landing ground run plus 2,500 feet flare distance exceeds 80 percent of the available runway.

A6.3.2.3. **(Added-MINOTAFB)** Host airfield managers may grant waivers when published maximum load bearing capacities for runways, taxiways and parking ramps are less than planned aircraft gross weight for landing, taxi or subsequent takeoff. Consult the Flight Information Handbook (FIH) for associated B-52 landing gear classification (TT) and Aircraft Classification Numbers (ACN) requirements.

A6.4. (Added-MINOTAFB) Planning. ASLOs/aircrew will refer to AFMAN 11-2B-52v3, B-52 Operations Procedures, and T.O. 1B-52H-1, Flight Manual, Strange Field Procedures.

A6.4.1. **(Added-MINOTAFB)** AC duties. Conduct all pre-departure briefing and coordination actions from ASLO handoff through commander approval/disapproval, to include: SSS, OSTF checklist, airfield suitability, event timeline, waivers and aircraft security.

A6.4.1.1. **(Added-MINOTAFB)** Contact 5 SFS/SFO to plan all security arrangements. Assess the threat, security presence, detection, entry control, and response capabilities of available resources. For example, security support provided at a public airport in the US which provides 24-hour-a-day patrol of the parking area, and which has controlled access to the flight line area may be considered adequate given the absence of an increased threat.

A6.4.1.2. **(Added-MINOTAFB)** When destination security is not available, consider not supporting the mission or using an alternate airfield with appropriate security.

A6.4.1.3. **(Added-MINOTAFB)** Upon arrival at the event airfield, ACs will provide 5 BW/CP the following information: phone number for an official 24-hour duty section that can function as a POC in case of an emergency, land time, maintenance status and aircrew phone roster.

A6.4.1.4. **(Added-MINOTAFB)** Aircraft will not be left unattended at locations where security is inadequate. During display periods, at least two crew members will remain with the aircraft for information and security purposes. Ensure the procedures are known for requesting civilian or military police assistance. ACs will ensure aircrew sanitize the aircraft if left overnight (i.e. remove all personal items, professional gear, and high-theft flight equipment, except parachutes).

A6.4.2. **(Added-MINOTAFB)** Copilot duties. Compute TOLD for event airfield. Determine fuel requirements (on-load at air show and return fuel required) and notify scheduling. For flights to civilian fields, ensure that the local fuel contractor has a government "INTO-PLANE" fuel contract. Complete Form F with extra equipment. Equipment in 47-Section weighs 541 lbs. and includes chocks, hydraulic fluid, oil, ladder, and spare chute. Extra equipment added to the cabin weighs 94 lbs. (includes toolbox and launch kit). Adjust Form F for extra crew luggage.

A6.4.3. **(Added-MINOTAFB)** WSO duties. Complete respective mission paperwork (charts, flight plan, weapon cards, EDP, etc.).

A6.4.4. **(Added-MINOTAFB)** EW duties. Coordinate the following: minimum "red bag" requirements with 5 OSS/A-7CC, and classified storage (comm kit, DTC, etc.).

A6.5. (Added-MINOTAFB) Departure. Aircrew will depart with the following items: TDY orders with variations authorized, ID card (DD Form 2AF), line badge, normal flying gear and manuals, signed flight orders for all planned flights and sufficient MARs and mission planning materials to cover the TDY.

Attachment 7 (Added-MINOTAFB)**TAXI-BACK LANDING AND QUICK TURN PROCEDURES**

A7.1. (Added-MINOTAFB) Taxi-Back Landings. Taxi-back landings with or without an Engine Running Crew Change (ERCC), shall use the “Taxi-Back Landing” checklist and adhere to 1B- 52H-1 taxi-back landing limitations.

A7.1.1. (Added-MINOTAFB) ERCC Output Mission Planning and Admin

A7.1.1.1. (Added-MINOTAFB) Thoroughly mission plan ERCC sorties.

A7.1.1.2. (Added-MINOTAFB) The output crew utilize the input crew Form F, DTC, RSD, and red bag. Ensure these items are present during aircrew changeover.

A7.1.1.3. (Added-MINOTAFB) If the ERCC sortie has planned AR and filing an alternate is required, ACs will ensure the planned fuel on board at the ARCT plus 15 minutes is sufficient to reach the Minot AFB initial approach fix (IAF) with required reserves for a possible divert.

A7.1.2. (Added-MINOTAFB) Taxi-Back Landing/ERCC Input Aircraft Recovery

A7.1.2.1. (Added-MINOTAFB) The ERCC input aircrew will contact 5 BW/CP or FOXTROT as soon as practicable and relay estimated land time, fuel on board, Code 3s, and any issues that would prevent the aircraft from being used as the ERCC input. FOXTROT will relay ERCC input status to the ERCC output crew through ICE PALACE.

A7.1.2.2. (Added-MINOTAFB) ERCC input aircrew will plan to land at scheduled time and 270,000 lbs gross weight, or slightly below.

A7.1.2.3. (Added-MINOTAFB) Deploy the drag chute if any of the 1B-52H-1 taxi-back landing limitations are not met. Additionally, do not perform taxi back landings on wet runways.

A7.1.2.4. (Added-MINOTAFB) After landing, and when clear of the runway, taxi-back landing aircrew will accomplish the following:

A7.1.2.4.1. (Added-MINOTAFB) Complete the “Taxi-Back Landing” checklist up to step 12. Wheel chocks are not required until after taxiing to the approach end.

A7.1.2.4.2. (Added-MINOTAFB) Taxi to the approach end using minimum braking and contact BOMBER/HAWK 1 on 321.0.

A7.1.2.4.3. (Added-MINOTAFB) Once maintenance receives confirmation that brakes are set and the radar is down, chocks will be installed, and the crew chief will make contact on interphone. Release brakes after chocks are confirmed in place and accomplish crew changeover.

A7.1.3. (Added-MINOTAFB) ERCC Aircrew Changeover.

A7.1.3.1. (Added-MINOTAFB) Unless coordinated otherwise, aircrew changeover will occur at the approach end hammerhead of the active runway.

A7.1.3.2. **(Added-MINOTAFB)** ERCC input ACs will fill in the applicable information on the AFTO Form 781H. Complete the AFTO Form 781A, Discrepancy Sheet and make a copy of aircraft write-ups for maintenance debrief. ACs will ensure the aircraft forms remain on the aircraft.

A7.1.3.3. **(Added-MINOTAFB)** Crewmembers shall enter and exit the aircraft well clear of engines with double hearing protection donned.

A7.1.3.4. **(Added-MINOTAFB)** One ERCC input pilot will remain in a pilot seat to guard brakes and monitor systems. All other crewmembers will vacate the aircraft and join the ERCC output crew on the bus for changeover.

A7.1.3.5. **(Added-MINOTAFB)** The ERCC input AC will conduct a changeover briefing with ERCC output AC covering the maintenance status, target trim, unstick speed, brake energy absorbed and landing time.

A7.1.4. (Added-MINOTAFB) Aircrew Changeover Completed

A7.1.4.1. **(Added-MINOTAFB)** Unless operational needs dictate, wait until the brake energy level will not enter the caution zone if abort is initiated at S1.

A7.2. (Added-MINOTAFB) Quick Turn Procedures. Quick Turn procedures are when a single aircraft flies two sorties on the same day and taxi-back landing procedures are not used. Quick Turns allow for reinstallation of the drag chute and for aircraft refueling, with aircrew members maintaining custody of the aircraft. Standard procedure is to stop on the centerline of the Mass Parking Apron (MPA) and get pushed back into a parking spot if fuel servicing is required. Unless previously coordinated, the output crew will bring their own Form F, DTC, RSD, and red bag.

A7.2.1. **(Added-MINOTAFB)** Comply with all 1B-52H-1 Quick Turn restrictions.

A7.2.2. **(Added-MINOTAFB)** The turn time is the time between the front-line scheduled land and turn line scheduled takeoff. Actual turn time will not exceed 4+15.

Table A7.1. (Added-MINOTAFB) Aircraft Turn Times.

Turn Type	Chute Repack	Push Back	Refuel	Turn Time
ERCC 1				1+00
Quick Turn 2,3,4	X			1+30
	X	X		2+00
	X	X	≤90k added	2+00
	X	X	>90k added	2+00
NOTES:				
Conduct Taxi-back Landing procedures IAW the 1B-52H-1				
Conduct Quick Turn procedures IAW the 1B-52H-1.				
Push back: Ensure anti-skid is off and bypass keys are installed. Turn anti-skid on and remove bypass keys when complete.				
Refueling: An AFTO Form 6 will be drafted and signed by the refueling team and the turn AC				

A7.2.3. (Added-MINOTAFB) Quick Turn Input Crew Procedures

A7.2.3.1. **(Added-MINOTAFB)** The input crew shall contact FOXTROT as soon as practical if landing after scheduled land time.

A7.2.3.2. **(Added-MINOTAFB)** The input crew shall accomplish the “Quick Turn Continuation- In Crew” checklist in lieu of the “After Landing” and “Before Leaving Aircraft” checklists.

A7.2.3.3. (Added-MINOTAFB) Post-flight Procedures

A7.2.3.3.1. **(Added-MINOTAFB)** Fill in the applicable information on the AFTO Form 781A & H. Take notes on non-grounding aircraft write-ups for maintenance debrief. Ensure the maintenance forms remain with the aircraft.

A7.2.3.3.2. **(Added-MINOTAFB)** A pilot will remain with the aircraft to guard the brakes for pushback and to manage refueling as needed. This pilot should use the oncoming crew’s transportation to return to the operations building for crew debrief after changeover is complete.

A7.2.3.3.3. **(Added-MINOTAFB)** Remaining input crewmembers depart using base transportation to maintenance debrief for debrief of non-grounding maintenance issues and for completion of standard post-flight paperwork. They then return to the operations building for debrief.

A7.2.4. (Added-MINOTAFB) Quick Turn Output Crew Procedures

A7.2.4.1. **(Added-MINOTAFB)** The output crew shall accomplish standard mission planning and step procedures, including generating a new Form F for the planned fuel load. They should accomplish the “Quick Turn Continuation-Out Crew” checklist in lieu of standard ground operations. If using Quick Turn procedures, aircrew shall use the following additions to account for local procedures, pushback, and refueling operations:

- A7.2.4.2. **(Added-MINOTAFB)** Before Exterior Inspection – Accomplished
- A7.2.4.3. **(Added-MINOTAFB)** Exterior Inspection – Accomplished
- A7.2.4.4. **(Added-MINOTAFB)** Fuel Quantity Check – Completed (P-CP)
- A7.2.4.5. **(Added-MINOTAFB)** Antiskid – ON, guard closed (P)
- A7.2.4.6. **(Added-MINOTAFB)** Ground, Remove Bypass Keys – Removed (GC)
- A7.2.4.7. **(Added-MINOTAFB)** Ground Locks and Bypass Keys – Six and two, counted and stowed (N)
- A7.2.4.8. **(Added-MINOTAFB)** Engine Start Clearance – Obtained (P/CP)

Attachment 8 (Added-MINOTAFB)**ARDA PROCEDURES****A8.1. (Added-MINOTAFB) General.**

A8.1.1. **(Added-MINOTAFB)** Aircraft refueling in AR-629 have airspace priority. Aircrew desiring to execute an ARDA may request (or ATC may direct) a lower penetration altitude for separation.

A8.2. (Added-MINOTAFB) Runway 12. Reference Figure A8.1. Aircrew will execute the following:

A8.2.1. **(Added-MINOTAFB)** File or request the MIB 115/025, east entry point (EEP), and remain at FL230 (or as assigned).

A8.2.2. **(Added-MINOTAFB)** Request the "ARDA Penetration" with Minot Approach.

A8.2.3. **(Added-MINOTAFB)** When cleared for the penetration, proceed from the EEP inbound to Minot AFB on a MC of 295°. Clearance for the penetration includes clearance to maneuver to make the inbound course at the EEP good.

A8.2.4. **(Added-MINOTAFB)** When directly overhead Minot AFB (MIB), make a right turn to MC 315° and start a descent to 12,000 feet MSL.

A8.2.5. **(Added-MINOTAFB)** At 20 DME from MIB and when level at 12,000 feet MSL, turn left to MC 115° and begin descent to 4,500 feet MSL. Call, "(Call sign), turning inbound, ARDA Runway 12" to Minot Approach.

A8.2.6. **(Added-MINOTAFB)** At 10 DME from MIB, start descent to a minimum decision altitude (MDA) of 2,267 feet MSL (600 feet HAT). The descent rate should not descend the aircraft below any published IAP restrictions. Missed Approach Procedures (MAP) will be per local procedures.

A8.3. (Added-MINOTAFB) Runway 30. Reference Figure A8.2. Aircrew will execute the following:

A8.3.1. **(Added-MINOTAFB)** File or request the MIB 295/025, west entry point (WEP), and remain at FL230 (or as assigned).

A8.3.2. **(Added-MINOTAFB)** Request the "ARDA Penetration" with Minot Approach.

A8.3.3. **(Added-MINOTAFB)** When cleared for the penetration, proceed from the WEP inbound to Minot AFB on a MC of 115°. Clearance for the penetration includes clearance to maneuver to make the inbound course at the WEP good.

A8.3.4. **(Added-MINOTAFB)** When directly overhead Minot AFB (MIB), turn left to MC 095° and start a descent to 12,000 feet MSL.

A8.3.5. **(Added-MINOTAFB)** At 20 DME from MIB and when level at 12,000 feet MSL, turn right to MC 295° and begin descent to 4,500 feet MSL. Call "(Call sign), turning inbound, ARDA Runway 30" to Minot Approach.

A8.3.6. (Added-MINOTAFB) At 10 DME from MIB, start descent to an MDA of 2,238 feet MSL (600 feet HAT). The descent rate should not descend the aircraft below any published IAP restrictions. Missed Approach Procedures (MAP) will be per local procedures.

Figure A8.1. (Added-MINOTAFB) Runway 12 ARDA.

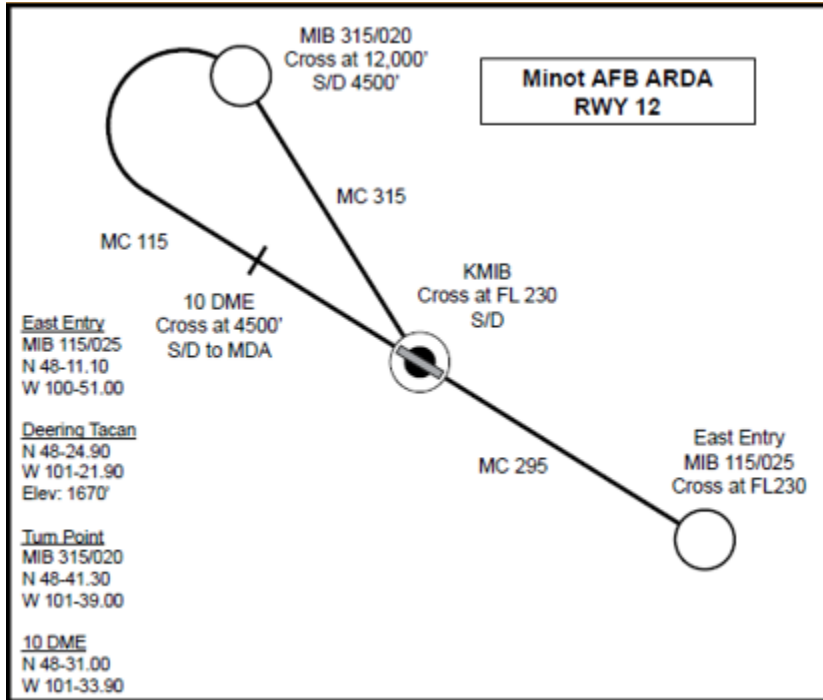
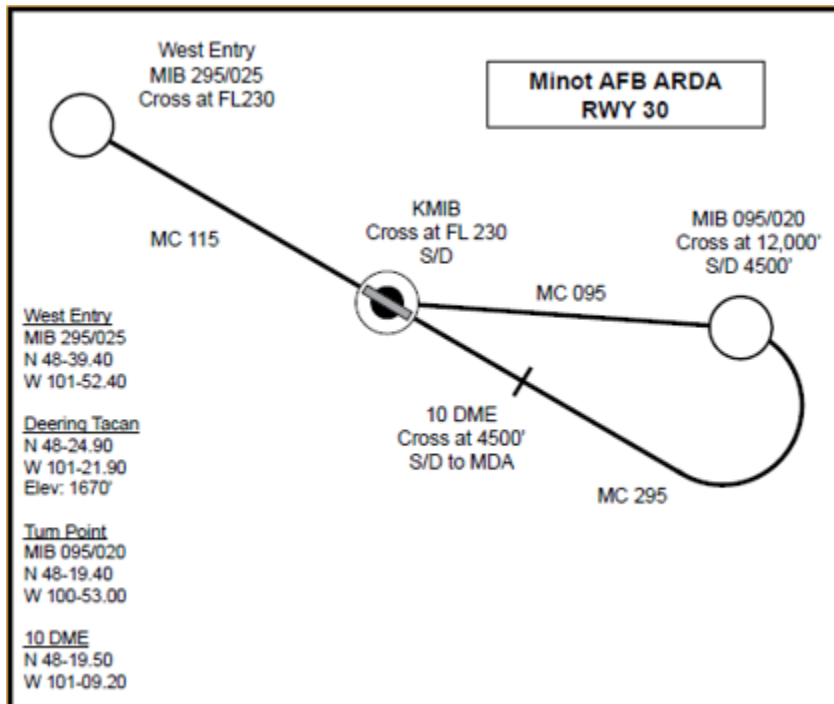

Figure A8.2. (Added-MINOTAFB) Runway 30 ARDA.



Attachment 9 (Added-MINOTAFB)**TAXI LANES AND OBSTRUCTION CLEARANCE**

A9.1. (Added-MINOTAFB) MPA and Alternate Parking Apron (APA). Areas are depicted in [Figure A9.1](#) and [Figure A9.2](#), respectively. They are the only areas on the airfield that have lines for obstruction clearance of 25 feet during B-52 taxi operations. The APA lines for 25 feet clearance are the dashed yellow lines, and the MPA lines for 25 feet clearance are the white dashed centerline for the driving lanes. Aircrew will make sure obstructions are outside these lines before commencing taxi operations in the MPA or APA.

A9.2. (Added-MINOTAFB) Outside the MPA and APA, there are no 25-foot obstruction clearance lines. On most Minot AFB taxiways, B-52 wings extend 5 feet beyond the edge of the prepared surface. To ensure the required 25-foot wingtip obstruction clearance, pilots will have to visually ensure a 30-foot obstruction clearance from the edge of the hard surface of the taxiway. A good visual reference for this clearance is the width of the taxiway asphalt shoulder itself which is 50 feet (Taxiway Echo shoulders are 58.5 feet). If an obstruction appears to be closer than this from the taxiway edge as depicted by the green area in [Figure A9.3](#) or if ever in doubt of safe obstruction clearance, STOP! Coordinate for ground personnel to move the obstruction or provide a qualified spotter (maintenance or operations personnel) to assist with taxiing.

Figure A9.1. (Added-MINOTAFB) MPA Taxi Obstruction Lines.



Figure A9.2. (Added-MINOTAFB) APA Taxi Obstruction Lines.

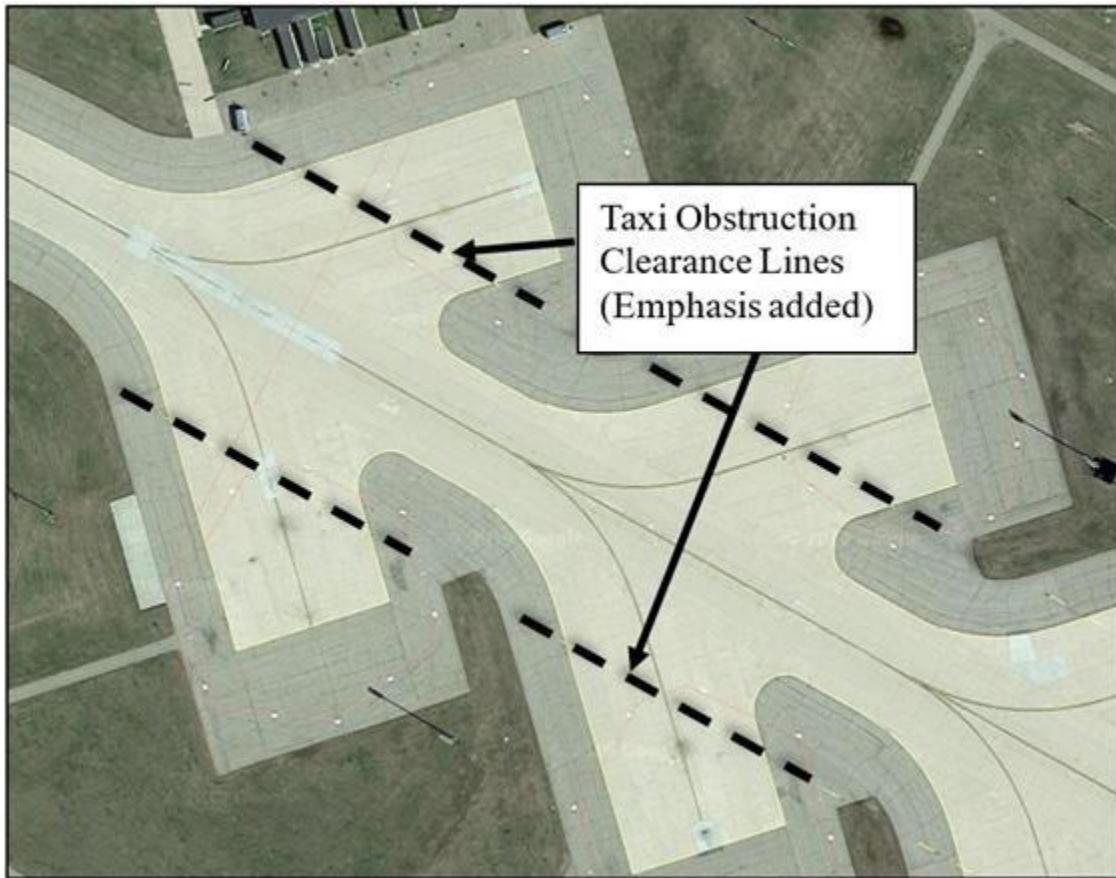
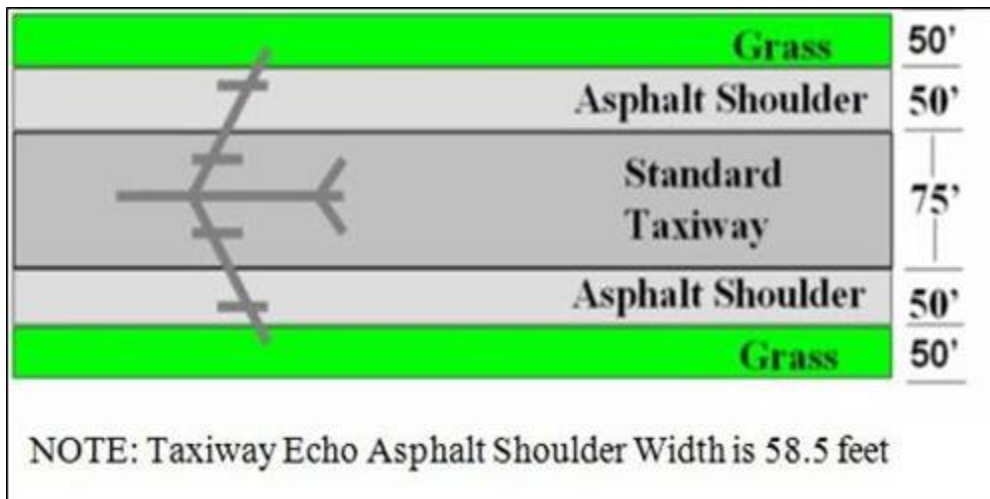

Figure A9.3. (Added-MINOTAFB) Taxiway Wingtip Clearance.



Attachment 10 (Added-MINOTAFB)**TECHNICAL ORDERS CONTROL**

A10.1. (Added-MINOTAFB) Distribution. 5 OGV is the OPR for the 5 OG Flight Manuals Program (FMP). 5OG Technical Order Distribution Officer (TODO) is assigned to 5OG/OGV. 5OG TODO will designate and provide oversight to all unit Technical Order Distribution Alternates (TODA). TODAs will manage unit accounts and request assistance and provide feedback to 5 OG/TODO.

A10.2. (Added-MINOTAFB) Responsibilities. IAW AFI11-215, Flight Manuals Program (FMP), each crew member is responsible for the condition and currency of all issued technical orders. represents T.O.s that should be maintained and not necessarily carried in flight. Comply with AFGSCI 11-270 requirements for carriage of paper and/or electronic publications on B-52 missions.

Table A10.1. (Added-MINOTAFB) Aircrew T.O. Requirements.

Technical Order	Title	Pilot	WSO	EWO
1B-52H-1	FLIGHT MANUAL	E	E	E
1B-52H-1CL-1	P, CP CL	P		
1B-52H-1-1	PERFORMANCE	E		
1B-52H-1-2	COMM SYSTEMS	E	E	E
1B-52H-1-2CL-1	COMM SYSTEMS CL	P	P	P
1B-52H-1-12	RN/N MANUAL		E	
1B-52H-1-12CL-1	RN/N CHECKLIST		P	
1B-52H-1-13	EW MANUAL			E
1B-52H-1-13CL-1	EW CHECKLIST			P
1B-52H-30-4	AGM-86B	E	E	E
1B-52H-30-4CL-1	AGM-86B CL	E	P	E
1B-52H-34-2 Series	WPN T.O.	E	E	E
1B-52H-34-2 Series CL-1	WPN CHECKLISTS	E	P	E
1-1M-34-CD-1	WPN MANUAL	E	E	E
NOTES: “E” indicates a requirement to maintain an electronic copy of that T.O./checklist (CL). “P” indicates a requirement to maintain a paper hard copy of that T.O./CL. Crews may maintain a paper copy in lieu of an electronic copy.				

Attachment 11 (Added-MINOTAFB)

WEAPONS FLOW CHART

Figure A11.1. (Added-MINOTAFB) Weapons Flow Chart.

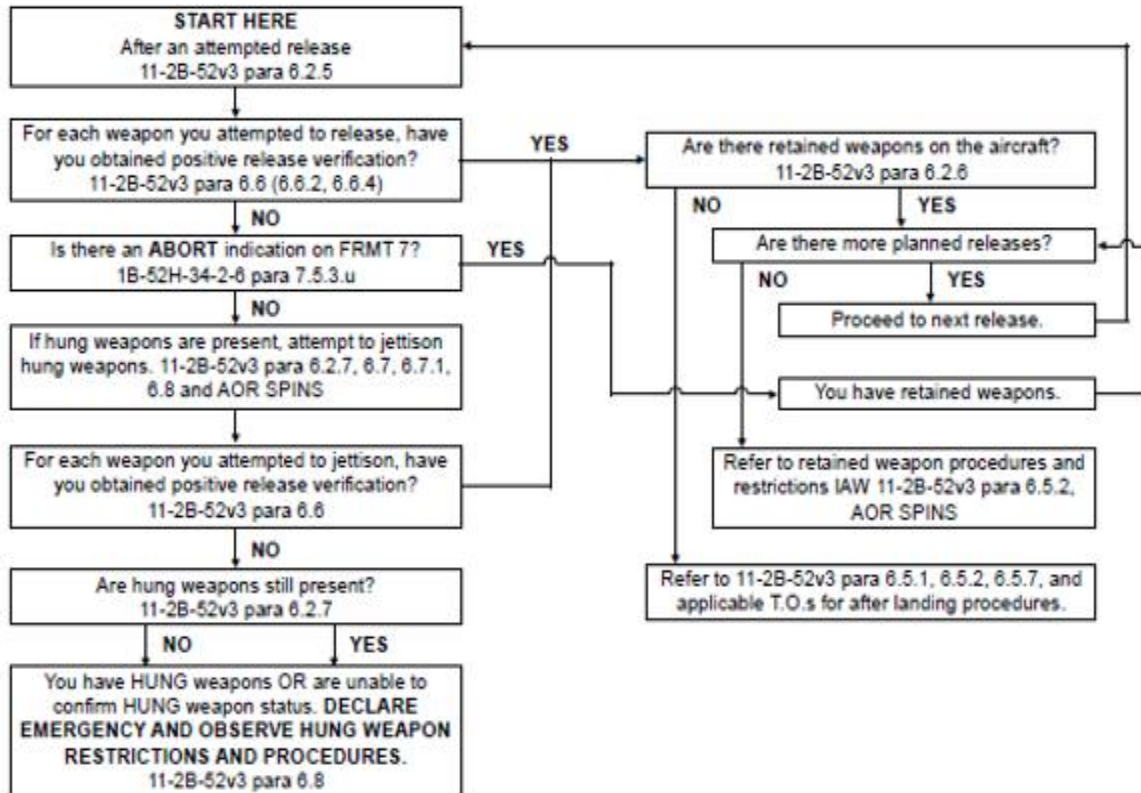

- 6.2.5. Attempted Release. Aircrew have properly configured for release (or jettison) and the bombing system has issued a release pulse or command.
- 6.6.2. Training. Visual confirmation between weapon releases is not required as long as the OAS/bomb indicator lights do not indicate (a) hung weapon(s). Aircrew with hung weapon indications will follow hung weapons procedures unless/until their status is changed. (T-3).
- 6.6.4. For RIU weapons, aircrew should obtain visual confirmation prior to departing the range or employment area. If the aircrew cannot obtain visual confirmation that no weapons are hung, they will adhere to hung weapons procedures unless/until their status is changed. (T-2).
- 6.8. Hung Weapon Procedures. If a weapon is known or suspected to be hung and cannot be visually confirmed to have separated from the aircraft, comply with the following. If a jettison is appropriate and can be visually confirmed, or hung indications are resolved by visual confirmation, leaving only retained weapons or no weapons, crews may return to normal guidelines. 1760 weapons that do not display "xy:HUNG" should be considered retained. Advise maintenance personnel on landing and annotate in forms. (T-3).
- 6.8.1. Do not attempt any further releases, except as provided in paragraph 6.6.3. (T-3).
- 6.8.2. If necessary, accomplish the bomb bay check. Due to risk to personnel, such checks should not be attempted unless a specific compelling need exists to enable additional releases or follow-on activity rather than applying hung weapons restrictions. (T-2).
- 6.8.3. During recovery, comply with restrictions for carried weapons. Additionally, accomplish air refueling only if required to recover the aircraft. (T-3). Do not rotate the CRL/CSRL. (T-3). Avoid overflight of populated areas, do not accomplish simulated emergency training, and fly a single approach to a full stop. (T-2).
- 6.8.4. Aircraft with hung weapons will declare an emergency prior to landing (T-3). Aircrew with hung weapons will accomplish a ground weapons check with maintenance immediately after landing and will follow locally developed guidance for safe recovery and de-arming. (T-3).
- 8.34.4. (Added) Weapon Jettison Procedures. Plan weapon jettison over the primary release target or authorized jettison target/location. Refer to guidance in the applicable range guide and SPINS. Coordinate with the Range Control Officer (RCO) prior to any jettison attempt. For suspected or actual hung internal munitions, perform a bomb bay check prior to jettison IAW T.O. 1B-52H-1 and 1B-52H-34-2-1 guidance.
- 1B-52H-34-2-6 para 7.5.3.u. (pg 7-119) xy:HUNG indication for 1760 weapons indicates a HUNG weapon, declare an emergency and observe hung weapon restrictions and procedures in 11-2B-52v3 para 6.8 (stated above)

Attachment 12 (Added-MINOTAFB)**COLD WEATHER OPERATIONS ANNEX****A12.1. (Added-MINOTAFB) De/Anti-Icing Definitions.**

A12.1.1. **(Added-MINOTAFB)** De-icing: process of removing accumulations of snow, frost, slush, and/or ice from the aircraft critical surfaces, crevices, openings, and hinge points.

A12.1.2. **(Added-MINOTAFB)** Anti-icing: process of preventing further accumulations of snow, frost, slush, and/or ice on clean aircraft critical surfaces by the application of AMS 1428 Type II or IV fluids.

A12.1.3. **(Added-MINOTAFB)** Holdover Time (HOT) – The estimated time a fluid prevents the formation of ice, snow, frost, or slush from reforming on surfaces under conditions of freezing precipitation. The time begins when the fluid first touches the aircraft. HOT depends on precipitation intensity and OAT. See FAA Holdover Time Guidelines for further information. HOT tables exist for flaps up and flaps down fluid application (i.e., Type IV Holdover Times vs Adjusted Type IV Holdover Times). Aircrew will utilize the most current and applicable table.

A12.2. (Added-MINOTAFB) Minot AFB De-icing and Anti-icing Fluid Properties and Operation.

A12.2.1. **(Added-MINOTAFB)** De/Anti-icing fluids must be tested every 12 months to ensure that the fluid conforms to SAE AMS 1424/1428 standards. De-icing fluid may be stored for 2 years under normal conditions.

A12.2.2. (Added-MINOTAFB) Type I De-ice Fluid (AMS 1424)

A12.2.2.1. **(Added-MINOTAFB)** Minot AFB uses Polar Plus LT deicing fluid by Cryotech Deicing Technology.

A12.2.2.2. **(Added-MINOTAFB)** De-icing fluid is diluted with water to a specific ratio based on OAT. This ratio can be adjusted/changed only when the truck is initially filled or when drained/refilled. Filling an empty truck requires ~1 hour while draining and refilling could take 2 to 3 hours.

A12.2.2.3. **(Added-MINOTAFB)** De-icing fluids have a negligible holdover capability and should not be used for anti-icing purposes. If takeoff does not immediately follow de-icing and ambient conditions result in frozen contaminants on the airplane, delay takeoff and complete de/anti-icing.

A12.2.3. (Added-MINOTAFB) Type IV Anti-ice Fluid (AMS 1428)

A12.2.3.1. **(Added-MINOTAFB)** Minot AFB uses Polar Guard Advance by Cryotech Deicing Technology.

A12.2.3.2. **(Added-MINOTAFB)** Anti-ice fluid is used at full strength (not diluted).

A12.2.4. (Added-MINOTAFB) Application

A12.2.4.1. **(Added-MINOTAFB)** All trucks can perform both de-ice and anti-ice operations since the fluids are stored in separate tanks on the trucks.

A12.2.4.2. **(Added-MINOTAFB)** De-icing fluid is typically heated to a range of 160° to 200° with a desired temperature of 180°. Anti-ice fluid is not heated when applied.

A12.2.4.3. **(MINOTAFB) MINOT AFB.** Aircraft should be de-iced 4 hours prior to launch and again prior to engine start if requested or if conditions warrant.

A12.2.4.4. **(MINOTAFB) MINOT AFB.** On inclement weather days SOF will proceed to the ramp prior to crew showtime at aircraft to ensure de-icing accomplishment.

A12.2.4.5. **(MINOTAFB) MINOT AFB.** See T.O. 1B-52H-1 “Snow and Ice Removal” for additional procedures and information.

Figure A12.1. (MINOTAFB) De-iced wing without contamination.



Figure A12.2. (MINOTAFB) De-iced wing with ice crystal contamination present.

