

**BY ORDER OF THE
SECRETARY OF THE AIR FORCE**



AIR FORCE MANUAL 11-231

18 NOVEMBER 2020

**AIR FORCE SPECIAL OPERATIONS
COMMAND
Supplement**

24 NOVEMBER 2021

Flying Operations

**COMPUTED AIR RELEASE POINT
PROCEDURES**

COMPLIANCE WITH THIS PUBLICATION IS MANDATORY

ACCESSIBILITY: Publications and forms are available for downloading or ordering on the e-Publishing website at www.e-Publishing.af.mil.

RELEASABILITY: There are no releasability restrictions on this publication.

OPR: AMC/A3TW

Certified by: AF/A3T
(Maj Gen James A. Jacobson)

Supersedes: AFI 11-231, 31 August 2005

Pages: 106

(AFSOC)

OPR: USAF/AFSOC/A3V

Certified by: AFSOC/A3V
(Col Michael C. Guisnard)

Pages: 9

This manual implements Air Force Policy Directive (AFPD) 11-2, *Aircrew Operations*, by prescribing standard methods and terminology for employment of the Computed Air Release Point (CARP) system. This system governs aircrew involved in computing air release point data during employment phases of aerial delivery operations. This manual applies to all civilian employees and uniformed members of the Regular Air Force, Air Force Reserve, and Air National Guard. Ensure all records generated as a result of processes prescribed in this publication adhere to Air Force Instruction 33-322, *Records Management and Information Governance Program*, and are disposed in accordance with the Air Force Records Disposition Schedule, which is located in the Air Force Records Information Management System. Refer recommended changes and questions about this publication to the office of primary responsibility (OPR) using the AF Form 847, *Recommendation for Change of Publication*. Route AF Form 847 from the field through Major Command (MAJCOM) publications/forms managers. Send comments and suggested improvements to this publication on AF Form 847, through channels, to Air Mobility Command

(AMC), Operations, Strategic Deterrence and Nuclear Integration Directorate, Flight Operations Division, Weapons and Tactics Branch (A3TW), 402 Scott Drive Unit 3A1, Scott AFB IL 62225-5302. MAJCOMs, direct reporting units (DRUs) and field operating agencies (FOAs) may supplement this manual. MAJCOMs, DRUs and FOAs will coordinate their supplement to this manual with AMC/A3TW before publication and forward one copy to AMC/A3TW after publication. The authorities to waive wing/unit level requirements in this publication are identified with a Tier (“T-0, T-1, T-2, T-3”) number following the compliance statement. See Department of the Air Force Instruction (DAFI) 33-360, *Publications and Forms Management*, for a description of the authorities associated with the Tier numbers. Submit requests for waivers through the chain of command to the appropriate Tier waiver approval authority, or alternately, to the requestor’s commander for non-tiered compliance items. The use of the name or mark of any specific manufacturer, commercial product, commodity, or service in this publication does not imply endorsement by the Air Force.

(AFSOC) AFMAN 11-231, *Computed Air Release Point Procedures*, is supplemented as follows: This supplement implements Air Force Special Operations Command (AFSOC) specific guidance and applies to commanders, operations and maintenance supervisors, and aircrews assigned or attached to all flying activities of AFSOC. This publication applies to the Regular Air Force, the Air Force Reserve, and the Air National Guard. This publication does not apply to the United States Space Force. Ensure that all records generated as a result of processes prescribed in this publication adhere to Air Force Instruction 33-322, *Records Management and Information Governance Program*, and are disposed in accordance with the Air Force Records Disposition Schedule, which is located in the Air Force Records Information Management System. Refer recommended changes and questions about this publication to the Office of Primary Responsibility (OPR) using the AF Form 847, *Recommendation for Change of Publication*; route AF Forms 847 from the field through the appropriate functional chain of command. This publication may be supplemented at any level, but all Supplements must be routed to the OPR of this publication for coordination prior to certification and approval. The authorities to waive wing/unit level requirements in this publication are identified with a Tier (“T-0, T-1, T-2, T-3”) number following the compliance statement. See DAFI 33-360, *Publications and Forms Management*, for a description of the authorities associated with the Tier numbers. Submit requests for waivers through the chain of command to the appropriate Tier waiver approval authority, or alternately, to the requestor’s commander for non-tiered compliance items in accordance with [paragraph 1.5](#) Compliance with the attachments in this publication are mandatory

SUMMARY OF CHANGES

This document is substantially revised and must be completely reviewed. Revisions include incorporating information pertaining to the Joint Precision Airdrop System (JPADS), Improved Containerized Delivery System (ICDS), Low Cost Aerial Delivery System (LCADS), and Low Cost Low Altitude (LCLA) airdrop and ballistic data. Ballistics data has been removed and is maintained online.

(AFSOC) This supplement aligns AFSOC requirements with AFMAN 11-231. Changes include: Successful airdrop criteria, center stick targeting procedures, minimum drop zone criteria, double

bag static line definition, and authorized software for leaflet airdrop planning. This document has been substantially revised to remove information incorporated in AFMAN 11-231.

Chapter 1—INTRODUCTION	8
1.1. General.....	8
1.2. Intended Use.....	8
1.3. Administration.....	8
1.4. Deviations.....	8
1.4. (AFSOC) Deviations.....	8
1.5. Waivers.....	8
1.5. (AFSOC) Waivers.....	9
1.6. Individual Circular Error Record.....	9
1.7. Successful Airdrop Criteria.....	9
1.8. CARP.....	9
Chapter 2—ROLES AND RESPONSIBILITIES	10
2.1. General.....	10
2.1. (AFSOC) General.....	10
2.2. Pilot in Command Authority.....	10
2.3. MAJCOM A3, Operations Directorate.....	10
Chapter 3—COMPUTED AIR RELEASE POINT SYSTEM	11
3.1. General.....	11
3.2. Responsibility.....	11
3.3. Methods of Airdrop.....	12
3.4. Types of Airdrop.....	12
3.5. Governing Factors.....	12
3.6. Parachute Characteristics.....	14
3.7. Drop Winds.....	15
3.8. Drop Zones.....	15
Figure 3.1. CARP Diagram.....	16
Chapter 4—COMPUTED AIR RELEASE POINT SOLUTIONS	17
4.1. General.....	17
4.2. Basic CARP Solutions.....	17
Figure 4.1. Corrected Drop Altitude Formula.....	17

Figure 4.2.	True Airspeed Formula.....	18
Figure 4.3.	Adjusted Rate of Fall Formula.....	18
Figure 4.4.	Average Temperature Formula.....	18
Figure 4.5.	Average Pressure Altitude Formula.....	18
Figure 4.6.	Time of Fall Formula.....	19
Figure 4.7.	Drift Effect.....	19
Figure 4.8.	Forward Travel Distance Formula.....	20
Figure 4.9.	Stopwatch Time Formula.....	20
Figure 4.10.	Usable DZ Time Formula.....	20
Figure 4.11.	Sample CARP Solution.....	22
4.3.	Plotting Instructions.....	23
Figure 4.12.	CARP Plotting Diagram.....	23
Chapter 5—HIGH ALTITUDE RELEASE POINT SOLUTIONS		24
5.1.	General.....	24
5.2.	Responsibilities.....	25
5.3.	Equipment.....	26
5.4.	Basic Assumptions.....	27
5.5.	Altitudes and Altimeters.....	27
5.6.	Ballistic Wind Determination.....	28
5.7.	HARP Principles.....	28
Figure 5.1.	HALO HARP Diagram.....	32
Figure 5.2.	HAHO HARP Diagram.....	33
5.8.	Completion of the AF Form 4015.....	33
Figure 5.3.	Drop True Altitude Formula.....	34
Figure 5.4.	Actuation Pressure Altitude Formula.....	35
Figure 5.5.	Absolute Actuation Altitude Formula.....	35
Figure 5.6.	High Velocity Mid-Pressure Altitude Formula.....	35
Figure 5.7.	High Velocity Adjusted Rate of Fall Formula.....	35
Figure 5.8.	High Velocity Time of Fall Formula.....	36
Figure 5.9.	High Velocity Drift Effect Formula.....	36
Figure 5.10.	Delay Distance Formula.....	36
Figure 5.11.	Deployed Mid-Pressure Altitude Formula.....	37
Figure 5.12.	Deployed Adjusted Rate of Fall Formula.....	37

Figure 5.13.	Total Deployed Time Formula.....	38
Figure 5.14.	Deployed Drive Time Formula.....	38
Figure 5.15.	Deployed Wind Effect Formula.....	38
Figure 5.16.	Deployed Drive Time Formula.....	38
Figure 5.17.	Forward Travel Distance Formula.....	39
Figure 5.18.	Stopwatch Time Formula.....	39
Figure 5.19.	Usable Green Light Length Formula.....	40
Figure 5.20.	Usable Green Light Time Formula.....	40
5.9.	Sample HARP Problem.....	40
Figure 5.21.	Sample AF Form 4015.....	42
5.10.	HARP Computation Using Formulas.....	43
Figure 5.22.	Total Wind Effect Formula.....	43
Figure 5.23.	Deployed Wind Effect Formula.....	43
Figure 5.24.	High-Velocity Drift Effect Formula.....	44
Figure 5.25.	Deployed Drive Distance Formula.....	44
5.11.	HARP Computation Using the Formula $D=KAV$	44
5.12.	Determining Drive Distance for the LAR.....	45
Figure 5.26.	Deployed Drive Distance in Meters Formula.....	45
Figure 5.27.	Deployed Wind Effect in Meters Formula.....	45
5.13.	HALO Plotting Instructions.....	45
Figure 5.28.	DDE Plot.....	45
Figure 5.29.	HVDE Plot.....	46
Figure 5.30.	FTD Plot.....	46
Figure 5.31.	DD Plot.....	47
5.14.	HAHO TDD Calculation.....	47
Figure 5.32.	HAHO TDD Formula.....	47
5.15.	HAHO Plotting Instructions.....	47
Figure 5.33.	HAHO HARP.....	48
Figure 5.34.	HAHO LAR.....	48
Figure 5.35.	Non-Standard Jumper Route of Flight.....	49
5.16.	In-Flight Updates.....	49
5.17.	Drop Documentation.....	49
5.18.	K-Factor.....	49

Figure 5.36.	USAF K-Factor Formula.	49
Chapter 6—LEAFLET RELEASE COMPUTATIONS		51
6.1.	General.....	51
6.2.	Mission Planning.	51
Figure 6.1.	Sequence of Events in a Leaflet Release.	52
Figure 6.2.	Multiple Bundle Release.....	53
Figure 6.3.	Determination of Major Axis and Target Length.	53
6.3.	Low Altitude Release Procedures (Method 1).....	54
Figure 6.4.	Preflight Data Example.....	54
Figure 6.5.	Low Altitude Leaflet Computation Sample (AF Form 4011).....	57
Figure 6.6.	Reverse Side of AF Form 4011.	58
6.4.	Low Altitude Release Procedures (Method 2).....	58
Figure 6.7.	Leaflet Drift Chart - 3000 Feet.	59
Figure 6.8.	Leaflet Drift Chart - 2500 Feet.	60
Figure 6.9.	Leaflet Drift Chart - 2000 Feet.	62
Figure 6.10.	Leaflet Drift Chart - 1500 Feet.	64
Figure 6.11.	Leaflet Drift Chart - 1000 Feet.	66
Figure 6.12.	Leaflet Drift Chart - 500 Feet.	69
6.5.	High Altitude Release Procedures.	71
Figure 6.13.	High Altitude Leaflet Computation Sample.	73
Figure 6.14.	Reverse Side of AF Form 4016 (Reverse).....	74
Figure 6.15.	Drift Vector Plot.	75
Figure 6.16.	Using Multiple Passes to Expand Major Axis.	76
6.6.	Accuracy Limitations.....	76
6.7.	(Added-AFSOC) Authorized Software.....	76
Chapter 7—SPECIAL PROCEDURES		77
7.1.	Ground Radar Aerial Delivery System (GRADS).....	77
Figure 7.1.	GRADS Graph Sample.	78
7.2.	General Radar Beacon Delivery Procedures.....	78
7.3.	Massive Ordnance Air Blast (MOAB) and C-130 Weapon System Delivery Procedures, General.	79
7.4.	Sight Angle Airdrop Technique.....	79
Figure 7.2.	Sight Angle Triangle.....	80

Figure 7.3.	Elevation Angle Chart.	81
Figure 7.4.	Placement of Scaling Markers.	83
7.5.	Infrared Detection Set (IDS) Airdrop (HC-130 or MC-130).	83
Figure 7.5.	IDS Depression Angle Airdrop Example.	84
7.6.	Rescue Airdrop Procedures.....	85
Table 7.1.	Rescue Airdrop Data.....	85
7.7.	Tri-wall Aerial Delivery System (TRIADS).....	86
7.8.	Maritime Craft Aerial Delivery System (MCADS) Rigid Hull Inflatable Boat (RHIB).	86
Chapter 8—C-17 AERIAL DELIVERY DATA		87
8.1.	C-17 Airdrop Airspeeds (in knots calibrated airspeed, KCAS).....	87
Table 8.1.	C-17 Airdrop Airspeeds (KCAS).....	87
8.2.	C-17 Airdrop Altitudes.	88
8.3.	Aerial Delivery Wind Limitations.	88
8.4.	C-17 Aerial Delivery Ballistics General.	88
Chapter 9—C-130 AERIAL DELIVERY DATA		89
9.1.	C-130 Aerial Delivery Airspeeds.....	89
Table 9.1.	C-130 Aerial Delivery Airspeeds (KIAS).....	89
9.2.	C-130 Aerial Delivery Altitudes.....	90
9.2.	(AFSOC) C-130 Aerial Delivery Altitudes.	90
9.3.	Aerial Delivery Wind Limitations.	90
9.4.	C-130 Aerial Delivery Parachute Ballistics.....	91
Attachment 1—GLOSSARY OF REFERENCES AND SUPPORTING INFORMATION		92
Attachment 2—ALTERNATIVE COMPUTED AIR RELEASE POINT SOLUTIONS		102
Attachment 3—(Added-AFSOC) SAMPLE COMPLETED AF FORM 4011 LOW ALTITUDE LEAFLET FORM.		113
Attachment 4—(Added-AFSOC) TARGETING CENTER STICK MINIMUM DZ SIZE TABLES.		114

Chapter 1

INTRODUCTION

1.1. General. This manual provides information for computed air release systems for airdrop of equipment and personnel.

1.2. Intended Use. This manual is intended for all US Air Force (USAF) aircrew members directly involved in computing air release points for airdrop operations of parachutists, equipment, supply bundles, and training bundles. AMC is the lead command for this manual. Individual MAJCOMs may supplement and waive elements of this manual for operational necessity. The T-2 waiver authority is the MAJCOM/A3 unless otherwise specified. Individual MAJCOMs will be responsible for providing HQ AMC ballistic data specific to their command or mission. Additionally, all lead MAJCOMs must identify which items in this manual apply to their aircrews for use in their specific mission. **Note:** Some aircraft are capable of computing wind adjusted release point solutions through onboard mission computers (MCs) without the use of procedures contained in this manual.

1.3. Administration. Organization commanders will ensure distribution of one copy per aircrew member who is directly involved in calculating air release points and one copy per operations section of airdrop tasked units. **(T-3).** Holders are responsible for posting revisions and changes.

1.3.1. Ballistics tables for this manual are updated and posted online as new information becomes available. The information is located in the AMC Aircrew Publications Library; Air Crew Pubs > Aircrew_Pubs_Library > Master_Library_Verified > Tactics Folder. The current link is: <https://cs2.eis.af.mil/sites/12679/aircrew%20pubs%20library/forms/better.aspx>

1.3.2. The data contained in the online ballistics tables supersedes all previous versions. When online data is unavailable, MAJCOM's tactics sections requiring ballistics data should have offline capability and maintain the most current appendices for aircrew use. If there is no online capability, crews should use the most current data that they have available.

1.3.3. **(Added-AFSOC)** All AFSOC cargo and personnel ballistic data will be derived from the most current version of the Approved Ballistic Data tables provided by AFLCMC (Air Transport Test Loading Activity (ATTLA) and/or HQ AMC unless changed by a more current FCIF. Due to continuous changes, ballistic data contained in any AFSOC Airdrop Computer Software (i.e., CAPS/CAT/XPLAN) will be checked against the most current Approved Ballistic Data tables. Any discrepancy will result in the member creating a "user defined chute" in the software to ensure ballistic accuracy. AFSOC Pilots, CSOs, Navigators and EWOs will check ballistic data for accuracy prior to conducting airdrop. **(T-2)**

1.4. Deviations. Aircrew may deviate from this manual to protect life, for safety of flight, or when an in-flight emergency requires immediate action. As soon as possible, inform respective MAJCOM of deviation and course of action taken.

1.4. (AFSOC) Deviations. Notify the AFSOC A3 via AFSOC/A3V of deviations to this AFMAN and Supplement.

1.5. Waivers. Directive guidance (will, shall, must, etc.) throughout this regulation are tiered IAW AFI 33-360, Publications and Forms Management. For examples of waivers and waiver

authorities, see AFI 33-360. Submit waiver requests through normal channels to respective MAJCOM. File approved waivers in the back of this manual until expired or rescinded.

1.5. (AFSOC) Waivers. Submit waiver requests of this AFMAN and Supplement to the AFSOC A3 via AFSOC/A3V. **(T-2)**

1.6. Individual Circular Error Record. Each unit should implement circular error (CE) records for aircrew members and aircraft responsible for CARP computations and who initiate the airdrop sequence (Not applicable to Air Combat Command (ACC), Air Force Special Operations Command (AFSOC), Air Education and Training Command (AETC); optional for C-17 or C-130Js when using MC calculated CARP). The following information will be considered when implementing a circular error average (CEA) program. **(T-3).**

1.6.1. CEA numbers should be updated every semi-annual period. Record a drop score over 600 yards as a 600 yards CE. Confirmed equipment malfunctions, troop exit delays, releases not controlled by the aircrew (such as jumpmaster directed airdrops), and racetracks should not be included in the computations.

1.6.2. AF Form 4012, *Individual Air Drop Circular Error Record*, is available for use.

1.7. Successful Airdrop Criteria.

1.7.1. Unilateral airdrop training (UAT). Successful criteria are determined by respective MAJCOM/A3.

1.7.1. **(AFSOC)** An airdrop is considered successful if 90% of the dropped load lands in recoverable condition within the Air Force Instruction (AFI) 13-217, *Drop Zone and Landing Zone Operations*, minimum drop zone (DZ) footprint. A successful airdrop does not preclude an aerial delivery review panel (ADRP) for an off DZ drop, malfunction, or injury and/or damage to personnel or property.

1.7.2. Other than UAT. Definition of a successful airdrop depends on supported commander's objectives. Typically an airdrop is considered successful if 90% of the dropped load lands in recoverable condition within the Air Force Instruction (AFI) 13-217, *Drop Zone and Landing Zone Operations*, minimum drop zone (DZ) footprint. A successful airdrop does not preclude an aerial delivery review panel (ADRP) for an off DZ drop, malfunction, or injury and/or damage to personnel or property.

1.8. CARP.

1.8.1. All low-altitude airdrops including supplies, equipment, and personnel using non-gliding canopies must use **Chapter 3** and **Chapter 4** CARP instructions unless otherwise specified in this manual. **(T-2).**

1.8.2. Personnel using gliding canopies must use **Chapter 5** High Altitude Release Point (HARP) instructions unless otherwise specified in this manual. **(T-2).**

Chapter 2

ROLES AND RESPONSIBILITIES

2.1. General. This chapter describes the roles and responsibilities of organizations involved in calculating a CARP. Commanders are responsible to ensure their crews are prepared to calculate CARPs in a variety of situations, not all of which can be covered in the document.

2.1. (AFSOC) General. AFSOC aircrews will compute a CARP/HARP solution for all airdrop operations IAW MDS specific manuals. **(T-2)**

2.2. Pilot in Command Authority.

2.2.1. The Pilot in Command (PIC), regardless of rank, is responsible for, and is the final authority for the operation of the aircraft.

2.2.2. This manual provides broad guidance and cannot address every situation. Aircrew should use best judgment to safely conduct flying operations.

2.3. MAJCOM A3, Operations Directorate.

2.3.1. For the purposes of this manual, flying MAJCOMS are: ACC, AETC, Air Force District of Washington, Air Force Global Strike Command, Air Force Materiel Command (AFMC), Air Force Reserve Command, AFSOC, AMC, Defense Intelligence Agency, National Guard Bureau, Pacific Air Forces, and United States Air Forces in Europe – Air Forces Africa, and Air Force Components to combatant commanders when led by a Commander, Air Force Forces (COMAFFOR).

2.3.2. MAJCOM A3s (or equivalent) are responsible for directing and training forces and for ensuring the respective operators are capable of accomplishing their CARP calculations.

Chapter 3

COMPUTED AIR RELEASE POINT SYSTEM

3.1. General. The CARP solution is based on average parachute ballistics and fundamental dead reckoning principles. These principles, laid out in this manual, minimize errors while providing ease of preflight and in-flight mission planning.

3.2. Responsibility. The pilot in command is ultimately responsible for ensuring a safe and accurate release point is calculated for all airdrops. The actual computation of the computed release point may be accomplished for a formation by a designated qualified aircrew member. However, each individual aircrew is responsible for its accuracy. The specific airdrop duties are in accordance with mission design series (MDS) specific guidance. At a minimum, aircrew members must establish and thoroughly brief all parameters associated with the release point. (T-3).

3.2.1. All personnel involved in airdrop should understand aerial delivery using a CARP is not an exact science. The system permits revisions close to the DZ and takes into considerations winds at various levels through which the parachute and load pass. When the aircrew member has a graphic presentation of the wind vectors and understands the characteristics of the parachutes used, they are better able to estimate the best release point.

3.2.2. Aircrew should be alert for changes in surface and altitude winds in the vicinity of the DZ. Often it is possible to spot a wind shear by observing a column of smoke. Information on winds at the different levels may not always be available. If this is the case, the aircrew member still can use the best known drop altitude and surface winds.

3.2.3. Last minute CARP changes may preclude detailed study of the CARP track by the pilot. The aircrew member, supporting the pilot flying, should be prepared to give directions and assist the pilot flying the aircraft in establishing the desired cross track for drift offset.

3.2.4. HC-130, MC-130, or EC-130 airdrops may be initiated in accordance with mission specific procedures.

3.2.5. C-17 and C-130J procedures. The C-17 and C-130J utilize an onboard mission computer system to compute a CARP solution. Both pilots are responsible for ensuring all computer entries are correct. The MC controls the time to airdrop sequence initiation, "Green Light." It also controls the end of usable DZ time, "Red Light," and updates the drift offset for the pilot to fly.

3.2.6. **(Added-AFSOC)** When using computer software for airdrop do not rely on software generated alerts to ensure airdrops are conducted within approved parachute parameters, and minimum drop zone size requirements. Software generated alerts may not be accurate in all instances or if the user-entered Drop Altitude or Actuation Altitude value is less than the minimum required for the selected parachute. AFSOC Pilots, Navigators, combat system officers (CSO) and Electronic warfare Officers (EWO) will verify results of all computer-generated products with the appropriate ballistic data listed within the ATTLA provided ballistics or active FCIF-released airdrop guidance to ensure planned drop altitudes are within the published performance parameters for the selected parachute and employment method (static line or MFF). Verification will be accomplished before conducting airdrop operations. (T-2)

3.3. Methods of Airdrop.

3.3.1. Personnel. Jumpers exit the aircraft under their own power.

3.3.2. Gravity. The aircraft maintains a “nose-high” attitude and in-flight release of load restraint allows the load to roll out of the aircraft. A rigging system may be used to initiate and accelerate load movement.

3.3.3. Extraction. An extraction device or parachute pulls the load from the cargo compartment.

3.3.4. Manual. The load is manually thrown or pushed from the aircraft (e.g., door bundles, standard airdrop training bundle (SATB), leaflets).

3.4. Types of Airdrop.

3.4.1. Free-Fall. Delivery of non-fragile items without the use of parachutes. Loads need special preparation to prevent damage from impact. The fall rate is approximately 130-150 feet per second (fps).

3.4.2. High velocity (HV). Delivery of certain supply items rigged in containers with an energy dissipater attached to the underside and slowed by a ring-slot parachute. The parachute stabilizes the load and retards the RoF to the point of acceptable landing shock. This system may include equipment loads dropped using reefed parachutes. The fall rate is approximately 65-100 fps.

3.4.3. Low velocity (LV). Delivery of personnel and various items of supply and equipment by use of cargo parachutes. Loads are prepared for airdrop by packing items in airdrop containers or by rigging them on platforms. The fall rate is approximately equal to or less than 28 fps.

3.4.4. Guided. Delivery of certain supply items rigged in containers with an energy dissipater attached to the underside and slowed by a parafoil. The parafoil is maneuvered by an autonomous guidance unit (AGU) which stabilizes the load and retards the RoF to the point of acceptable landing shock. The fall rate is approximately 20-30 fps.

3.5. Governing Factors.

3.5.1. The CARP is usually based on the first load to exit the aircraft except:

3.5.1.1. When door bundles precede personnel, compute separate CARPs for the personnel and for the bundle. **(T-2)**. Release the bundle on the personnel CARP after ensuring that the bundle will impact on the surveyed DZ. **(T-2)**.

3.5.1.2. JPADS mission planner (MP) allows the targeting of any single bundle in the stick.

3.5.1.3. Alternate bundle targeting. Aircrew may elect to target other than the first bundle exiting the aircraft to achieve a coordinated dispersal pattern. When utilizing these methods (i.e., center bundle, average flight station, etc.) aircrew will brief the user on expected ground dispersal. **(T-3)**. Aircrew will also ensure all planned loads for the release pass will remain within the confines of the given DZ. **(T-2)**.

3.5.1.3.1. **(Added-AFSOC)** Airdrop Center Stick Targeting Procedures.

3.5.1.3.1.1. **(Added-AFSOC)** AFSOC aircrew will use the data below, in addition to DAFMAN 13-217, when conducting Center Stick Targeting (also known as “bracketing the PI”) airdrop operations. Center Stick Targeting procedures are approved when airdropping CDS (including HVCDS, LCADS-LV, and LCADS-HV), CRS, CRL, HSLLDAS, LCLA, XCDS-HS, XCDS-LS, and Static Line Personnel. **(T-2)** Current AFMAN 11-231 and DAFMAN 13-217 guidance is based on the first object exiting the aircraft being targeted to land on a surveyed PI located near the leading edge of the DZ. Experience in deployed environments has shown that the more common employment method is to target the center of the stick to land on the center of the DZ. **(T-2) Note:** To account for the center bundle not rolling aft as soon as the release gate is cut, navigators/CSOs should call their “green light” call approximately 0.5 seconds early for manual gate cuts when targeting the center bundle (as opposed to the 1.5-second delay normally used for manual gate cuts).

3.5.1.3.1.2. **(Added-AFSOC)** Aircrews will use [Attachment 4](#) for determining minimum DZ size required for center stick targeting operations. During combat or contingency operations, the supported force will determine the minimum DZ size. **(T-2)**

3.5.1.3.1.2.1. **(Added-AFSOC)** DAFMAN 13-217 Table 3.2, Standard Point of Impact Placement, does not apply during Center Stick Targeting operations. During center stick targeting operations, standard PI placement is DZ center-point. **(T-2)**

3.5.1.3.1.2.2. **(Added-AFSOC)** The PI may be located anywhere within the surveyed DZ boundaries as long as the minimum required DZ size for that type airdrop and airdrop formation fits within the boundaries. All participants must be briefed when using this option. **(T-2)**

3.5.1.3.1.2.3. **(Added-AFSOC)** When center stick targeting procedures are used on existing surveyed drop zones, crews will ensure that the entire center stick targeting DZ (as computed IAW [paragraph 3.5.1.3.1.2](#)) fits within the boundaries of the original surveyed dz. All other DZ procedures remain unchanged. **(T-2)**

3.5.1.3.1.3. **(Added-AFSOC)** When performing CDS, HVCDS, LCADS-LV, LCADS-HV, XCDS-HS, or XCDS-LS, airdrops using center stick targeting procedures, crews will use the average weight of the stick for CARP computation purposes. Use the flight station position of the center of the stick for determining exit time. While this flight station and weight may not correspond exactly to any single bundle within the stick, this method provides an acceptable average for CARP computation. All other airdrop procedures related to CDS, HVCDS, LCADS-LV, LCADS-HV, XCDS-HS, or XCDS-LS remain unchanged. **(T-2)**

3.5.1.3.1.4. **(Added-AFSOC)** When performing LCLA, CRS, CRL, HSLLDAS, LCADS-HV, XCDS-HS, or XCDS-LS airdrops using center stick targeting procedures, crews will use the average weight of the stick for CARP computation purposes. Use the exit time from current applicable guidance. All other airdrop procedures related to LCLA, CRS, CRL, HSLLDAS XCDS-HS, or XCDS-LS

remain unchanged. **(T-2)**

3.5.1.3.1.5. **(Added-AFSOC)** When performing Static Line Personnel airdrops using center stick targeting procedures, crews will use the average weight of personnel in the stick for CARP computation purposes. Use the position of the center jumper in the stick for determining exit time, based on a one-second exit time for each jumper. For example, if there are 8 jumpers in the stick, “Green Light” would be called 3 seconds early for the fourth jumper to land on the PI. All other airdrop procedures related to Static Line Personnel remain unchanged. **(T-2)**

3.5.2. The actual ground pattern of sequentially airdropped loads depends on the following:

3.5.2.1. Time lapse between each load exiting the aircraft.

3.5.2.2. Aircraft stability from “Green Light” to last item exit (aircraft track, altitude, and airspeed).

3.5.2.3. Variation of loads and/or parachutes within a stick.

3.5.2.4. Ability of jumpers to see desired landing point and steer to it.

3.5.2.5. Weather (primarily winds).

3.5.3. Accurate airdrop requires timely DZ or target acquisition to assure proper alignment. The alignment or cross track drift offset, based on the most current winds, must be maintained by the pilot flying during the final approach to the release point and throughout the drop sequence. **(T-2)**.

3.6. Parachute Characteristics.

3.6.1. Parachute Ballistics. Each parachute has its own peculiarities. The ballistics given in the ballistics tables are acceptable averages. This average ballistic data is derived by the Air Transportability Test Loading Activity (ATTLA), AFMC, Air Force Life Cycle Management Center (AFLCMC), Wright-Patterson AFB, aerial delivery tests by US Army Airborne and Special Operations Test Directorate (ABNSOTD), US Army Developmental Test Command Yuma Test Center, and US Army Natick Soldier Research Development and Engineering Center (NSRDEC).

3.6.2. Foreign parachutists. When dropping foreign parachutists using host nation or commercial parachutes not listed in this manual, MAJCOM/A3 approval is required. **(T-2)**. The request should include all available ballistic data provided by the user or parachute manufacturer. MAJCOMs should coordinate with US Army NSRDEC and/or ATTLA to validate the ballistic data or provide an equivalent parachute type. The most recent USAF approved for use list (AFUL) for allied partner nation airdrop equipment and personnel parachute systems will be used when available. **(T-2)**. See [paragraph 5.1.2.5](#).

3.6.3. Gliding angle. Some parachutes (e.g., T-11) glide randomly in direction. Others (e.g., MC-6) are designed to glide in one direction. Unless the direction and speed of the glide are known, mission planners may not account for this value in the CARP.

3.6.4. Ballistics data entry. MAJCOM or ATTLA approved ballistics data may be used to overwrite aircraft MC ballistics.

3.7. Drop Winds. To accurately compute the wind effect on a load under canopy, planners must determine the mean effective wind (or ballistic wind) by averaging the wind vectors (direction and velocity) from airdrop altitude to the surface. **(T-3).** The drift effect is a function of the total time of fall (i.e., as time of fall increases, drift effect increases for a given ballistic wind). Wind observations taken as close to actual time over target (TOT) provide the most accurate data. As time elapses between observation and actual TOT, wind accuracy may degrade. Winds should not be averaged mathematically if the difference in directions exceeds 90° or if the difference in velocity exceeds 15 knots (kts). When this occurs, a vectorial average of the winds should be used in accordance with Air Force Pamphlet (AFPAM) 11-216, *Air Navigation* (See [paragraph 5.6.3.1](#) and [paragraph 5.6.3.2](#)). Wind sources include, but are not limited to, the following:

3.7.1. Forecast winds. Weather facilities report winds in true bearing. Normally, the weather forecaster is not trained to calculate the vectorial average of winds, therefore, the aircrew member should request winds at the needed altitudes and compute the average. The Air Force Weather Agency (AFWA) has wind information available at https://weather.af.mil/AFW_WEBS/ or https://weather.af.smil.mil/AFW_WEBS/ on Secret Internet Protocol Router Network (SIPRNet).

3.7.2. In-flight visual indications of wind (smoke, dust, etc.).

3.7.3. Electronic and navigation systems (Doppler, self-contained navigation system (SCNS), inertial navigation system (INS), global positioning system (GPS), light detection and ranging (LiDAR), etc.).

3.7.4. Ground party (Combat Control Team (CCT), Special Tactics Team (STT), and Drop Zone Controller (DZC)) furnish magnetic winds. The ground party may report winds as a mean effective wind (MEW). The MEW is an average wind, referenced in constant speed and direction, extending from the DZ surface to drop altitude. When verified with in-flight data, aircrews may consider the MEW a very desirable cross-check source for winds being utilized for the airdrop.

3.7.5. Real-time data collection source (dropsondes or weather balloons).

3.8. Drop Zones. See AFI 13-217 for drop zone information.

Figure 3.1. CARP Diagram.

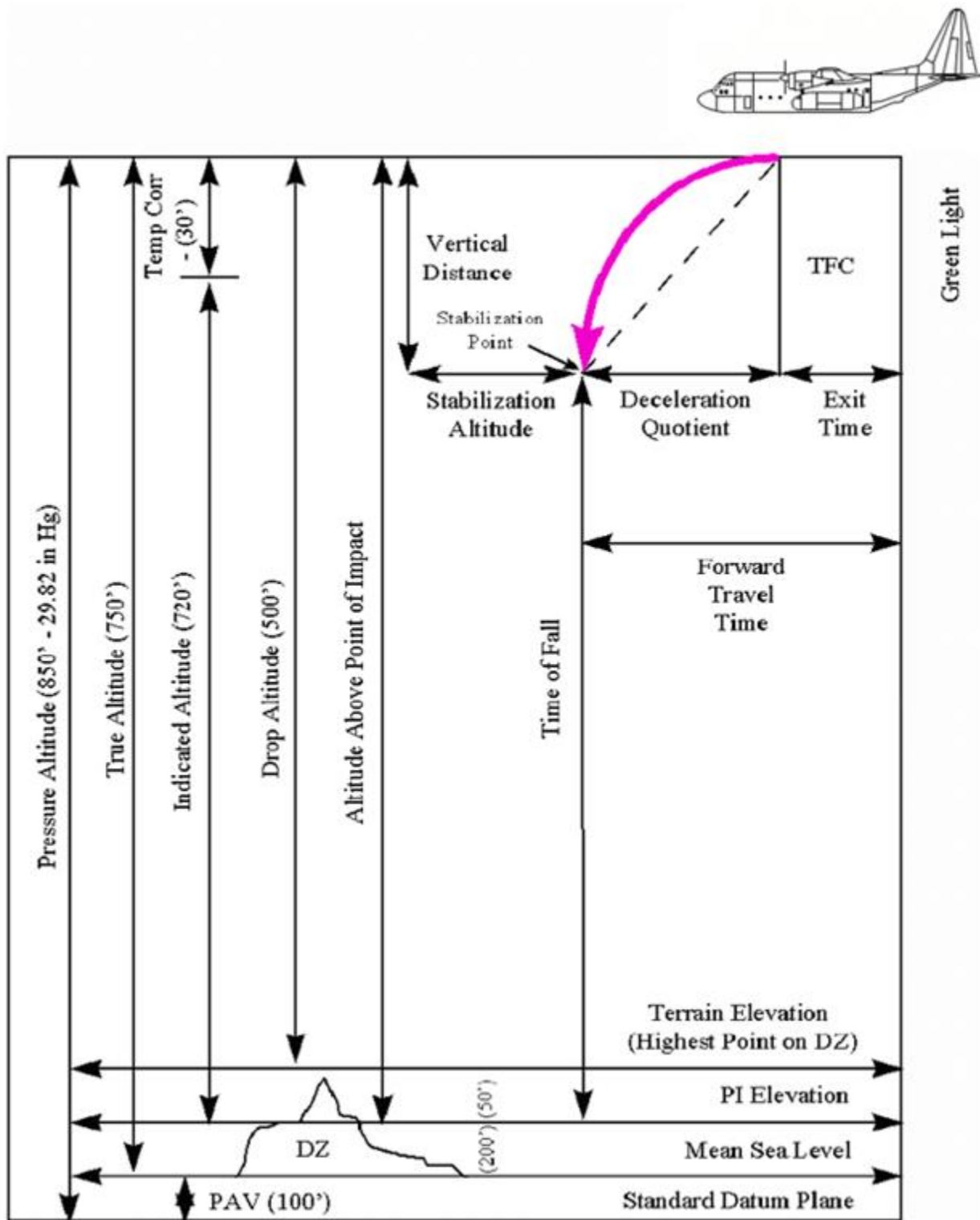

Chapter 4

COMPUTED AIR RELEASE POINT SOLUTIONS

4.1. General. The primary method of planning a CARP is through MAJCOM-approved mission planning software (MPS). Aircrew will use approved MPS to calculate CARPs. **(T-3).** Navigators, Combat System Officers (CSOs), and aircraft commanders will verify the accuracy of all MPS products. **(T-3).** The secondary or manual method for computing the air release point is the basic computer solution where all CARP requirements are solved using the MB-4 computer (whiz wheel). The formulas used in this chapter are based on use of the MB-4. During execution of C-17 and C-130J airdrop operations, CARPs are calculated in the MC. Parachute ballistic data is contained in a database within the MC. When necessary, this manual or MAJCOM-approved data can be manually entered when the parachute being used is not part of the MC database. Regardless of computation method, aircrew will brief all planned release points. **(T-3).**

4.2. Basic CARP Solutions. When necessary, the AF Form 4018, *Computed Air Release Point Computations*, or MAJCOM-approved software generated products, will be used by aircrew to solve and record data. **(T-3).** **Figure 3.1** provides sample CARP solutions for container delivery system (CDS), heavy equipment, and personnel. The basic steps for the AF Form 4018 are as follows:

- 4.2.1. Item 1. Drop altitude. Selected above ground level (AGL) drop altitude (absolute altitude) in feet.
- 4.2.2. Item 2. Terrain elevation. Elevation, in feet, of the highest point on the surveyed DZ.
- 4.2.3. Item 3. True altitude. Computed mean sea level (MSL) drop altitude, in feet (item 1 plus item 2). True altitude is the altitude to be flown when the altimeter setting is derived by in-flight altimeter calibration.
- 4.2.4. Item 4. Pressure altitude variation (PAV). The pressure difference, in feet, between mean sea level and the standard datum plane. PAV is computed by taking the difference between the forecast DZ altimeter setting and the standard day pressure (29.92 inches of Mercury) and multiplying by 10. PAV is positive if the forecast altimeter setting is less than 29.92 and negative if the forecast altimeter setting is greater than 29.92 (formula A).
- 4.2.5. Item 5. Pressure altitude. Drop altitude, in feet above the standard datum plane (Item 3 plus Item 4). Used to compute true airspeed and corrected drop altitude.
- 4.2.6. Item 6. Corrected drop altitude. Drop altitude corrected for air density by using formula B and the ALTITUDE CORRECTIONS window on the MB-4 computer. See **Figure 4.1**.

Figure 4.1. Corrected Drop Altitude Formula.

$$\frac{\text{True Altitude Temperature (Item 9)}}{\text{Pressure Altitude (Item 5)*}} = \frac{\text{Drop Altitude (Item 1)**}}{\text{Corrected Drop Altitude (Item 6)**}}$$

* Placed in the ALTITUDE CORRECTIONS WINDOW of the MB-4 computer.

** Drop altitude placed on the outer edge of the MB-4, corrected drop altitude is read on the inner wheel of the MB-4.

4.2.7. Item 7. Terrain elevation. Same as Item 2.

4.2.8. Item 8. Indicated altitude. The altitude to be flown with the DZ altimeter setting set in the barometric scale of the aircraft altimeter. Computed by adding the corrected drop altitude (Item 6) to terrain elevation (Item 7).

4.2.9. Item 9. True altitude temperature. Temperature at drop altitude in degrees Celsius used to compute Item 6 and Item 11.

4.2.10. Item 10. IAS/CAS/EAS. Indicated airspeed (IAS) for the drop as specified by the appropriate directives. Calibrated airspeed (CAS) equals IAS corrected for pitot static error, aircraft attitude, and instrument error. Equivalent airspeed (EAS) equals CAS corrected for compressibility.

4.2.11. Item 11. True airspeed. True airspeed (TAS) is computed on the MB-4 using the DENSITY ALTITUDE COMPUTATIONS window and the formula in [Figure 4.2](#).

Figure 4.2. True Airspeed Formula.

$$\frac{\text{True Altitude Temperature (Item 9)}}{\text{Pressure Altitude (Item 5)*}} = \frac{\text{True Airspeed (Item 11)**}}{\text{Equivalent Airspeed (Item 10)**}}$$

* Use the DENSITY ALTITUDE COMPUTATIONS window of the MB-4 computer.

** TAS is read from the outer wheel of the MB-4. EAS is read on the inner wheel.

4.2.12. Item 12. RoF. Extracted from the parachute ballistic data. This velocity is expressed in feet per second.

4.2.13. Item 13. Adjusted rate of fall (ARoF). RoF corrected for air density. Compute on the MB-4 computer using the DENSITY ALTITUDE COMPUTATIONS window and Formula C. See [Figure 4.3](#).

Figure 4.3. Adjusted Rate of Fall Formula.

$$\frac{\text{Average Temperature*}}{\text{Average Pressure Altitude*}} = \frac{\text{ARoF (Item 13)}}{\text{RoF (Item 12)**}}$$

* Average temperature is the average between true altitude temperature and surface temperature. See [Figure 4.4](#).

Figure 4.4. Average Temperature Formula.

$$\text{Average Temperature} = \frac{\text{True Altitude Temperature} + \text{Surface Temperature}}{2}$$

* Average temperature vs. average pressure altitude is read against the DENSITY ALTITUDE COMPUTATIONS window of the MB-4 computer. Average pressure altitude is calculated by taking item 5 minus one-half of item 1. See [Figure 4.5](#).

Figure 4.5. Average Pressure Altitude Formula.

$$\text{Average Pressure Altitude} = \text{Pressure Altitude (Item 5)} - \frac{\text{Drop Altitude (Item 1)}}{2}$$

** ARoF is read on the outer wheel of the MB-4.

- 4.2.14. Item 14. Altitude above point of impact (PI). The difference in feet between the true altitude and the PI measured in feet AGL (formula D).
- 4.2.15. Item 15. Vertical distance (VD). Extracted from the parachute ballistic data.
- 4.2.16. Item 16. Stabilization altitude. Item 14 minus item 15.
- 4.2.17. Item 17. Time of fall. The elapsed time, in seconds, it takes for the load to fall from stabilization altitude to the PI. Compute using formula E. See [Figure 4.6](#).

Figure 4.6. Time of Fall Formula.

$$\text{Time of Fall (Item 17)} = \frac{\text{Stabilization Altitude (Item 16)}}{\text{Adjusted RoF (Item 13)}}$$

- 4.2.18. Item 18. Time of fall constant (TFC). A time constant in seconds used to determine drift effect during the time the parachutist or load falls after exiting the aircraft until reaching the stabilization altitude. TFC is usually extracted from the parachute ballistic data.
- 4.2.19. Item 19. Total time of fall. Item 17 plus item 18.
- 4.2.20. Item 20. Ballistic wind. The expected wind, interpolated from all available sources, which affects the load on its way the ground. (Refer to [paragraph 5.6](#) for techniques to calculate ballistic wind.) CCT or STT furnished surface and mean effective winds are reported as magnetic, while onboard computers may provide winds in magnetic, true, or grid reference.
- 4.2.21. Item 21. Drift effect. Distance in yards computed using formula F. See [Figure 4.7](#).

Figure 4.7. Drift Effect

$$\frac{\text{Total Time of Fall (Item 19)}}{1.78 \text{ yards}^*} = \frac{\text{Drift Effect (Item 21)}}{\text{Ballistic Wind (Item 20)}}$$

The 1.78 constant is used to convert knots to yards per second. 1.94 constant is used to convert knots to meters per second. Item 21 may be divided to include space for drift effect based the increment used in constructing the wind circle (see [paragraph A2.2](#)).

- 4.2.22. Item 22. Drop altitude wind. Expected wind at drop altitude used to compute drift and groundspeed.
- 4.2.23. Item 23. DZ course. DZ centerline course referenced in magnetic, true, or grid obtained from the DZ survey or zone availability report (ZAR).
- 4.2.24. Item 24. Drift correction. Expected run-in heading correction necessary to parallel DZ course.
- 4.2.25. Item 25. DZ heading. Item 23 corrected by item 24.
- 4.2.26. Item 26. Groundspeed. Expected aircraft speed relative to the ground. Aircraft TAS corrected for forecast drop altitude winds
- 4.2.27. Item 27. Exit time (ET). Elapsed time, in seconds, from “green light” until the parachutist or load exits the aircraft. Obtained from parachute ballistic data.

4.2.28. Item 28. Deceleration quotient (DQ). A constant in seconds during airdrop tests that compensates for the nonlinear deceleration in forward speed of an airdrop item as it approaches stabilization. Obtained from parachute ballistic data.

4.2.29. Item 29. Forward travel time (FTT). Item 27 plus item 28 or extracted from the parachute ballistic data.

4.2.30. Item 30. Forward travel distance (FTD). Item 29 converted to distance using formula G. See **Figure 4.8**.

Figure 4.8. Forward Travel Distance Formula.

$$\frac{\text{Groundspeed (Item 26)}}{1.78\text{yds}/1.94\text{mtrs}} = \frac{\text{FTD (Item 30)}}{\text{FTT (Item 29)}}$$

4.2.31. Item 31. Stopwatch distance. Ground distance in yards along track from a timing point to the CARP.

4.2.32. Item 32. Stopwatch time. Item 31 converted to time, in seconds, using formula H. See **Figure 4.9**.

Figure 4.9. Stopwatch Time Formula.

$$\frac{\text{Groundspeed (Item 26)}}{1.78\text{yds}/1.94\text{mtrs}} = \frac{\text{Stopwatch Distance (Item 31)}}{\text{Stopwatch Time (Item 32)}}$$

4.2.33. Item 33. Usable DZ length. The distance in yards from the PI to the end of the DZ, minus the safety zone distance use formula I.

4.2.33.1. Personnel airdrops. During training missions aircrew will subtract 200 yards from the trailing edge to account for the safety zone. **(T-2). Exception:** With concurrence of the user, AFSOC and ACC units are not required to use a safety zone when dropping US SOF and/or Guardian Angel (GA) personnel.

4.2.33.2. Sequential heavy equipment. Aircrew will subtract 400 yards from the trailing edge for each additional platform during sequential heavy equipment extractions. **(T-2).**

4.2.33.3. Mass CDS. Aircrew will subtract 50 yards for each additional lateral row of containers. **(T-2). Note:** A lateral row is not the same as a stick.

4.2.34. Item 34. Usable DZ time. Item 33 converted to time, in seconds, using formula H. See **Figure 4.10**.

Figure 4.10. Usable DZ Time Formula.

$$\frac{\text{Groundspeed (Item 26)}}{1.78\text{yds}/1.94\text{mtrs}} = \frac{\text{Usable DZ Length (Item 33)}}{\text{Usable DZ Time (Item 34)}}$$

4.2.34.1. Not less than 3 seconds except when dropping High Speed Low Level Aerial Delivery System (HSLADS) and extracted CDS, high speed (XCDS-HS), which may be 2 seconds. **(T-2).**

4.2.34.2. The planned interval between each parachutist's exit is one second, therefore, this value equates to the maximum number (in addition to the first person exiting) of

paratroopers who can safely be dropped in a single stick (e.g., if formula H yields a time of 10 seconds, then the maximum number of paratroopers in each stick is 11). The number of sticks of personnel is equal to the number of troop doors in use during that pass, therefore the maximum number of troopers that can be dropped in a single pass is computed by multiplying the number of troop doors in use by the maximum number of troopers in a stick. During jumpmaster directed airdrops, the jumpmaster will determine the minimum allowable DZ time through coordination with the aircrew. **(T-3)**.

4.2.35. Item 35. Red light time. Total time from the timing point to the end of Usable DZ Time (Item 32 + Item 34).

Figure 4.11. Sample CARP Solution.

COMPUTED AIR RELEASE POINT COMPUTATIONS						DATE 1 Mar 10			
NAVIGATOR'S NAME (Print) <i>Laura Curvey</i>			CALL SIGN KANTO 24	ORGANIZATION 36 AS	NAVIGATOR'S SIGNATURE <i>Laura Curvey</i>				
FACTORS		DATA	DROP DATA	RESULTS					
1	DROP ALTITUDE	800	650	400	PREFLIGHT ALTIMETER SETTING	30.00	29.92	29.85	
2	TERRAIN ELEVATION +	560	560	560	DROP ZONE	ROCK	COYLE	PUDGY	
3	TRUE ALTITUDE	1360	1210	960	SCHEDULED DROP TIME(S)	2000	2100	2200	
4	PRESSURE ALTITUDE VARIATION + A	-80	0	70	LOAD	PER	HE	CDS	
5	PRESSURE ALTITUDE	1280	1210	1030	LOAD WEIGHT	225	3500	1200	
6	CORRECTED DROP ALTITUDE B	795	645	395	PARACHUTE (Type and number)	1 x MC1-1	2xG-12D	1xG-12D	
7	TERRAIN ELEVATION +	560	560	560	FLIGHT STATION OF LOAD	DOOR	540	737	
8	INDICATED ALTITUDE	1355	1205	955	$\begin{matrix} \frac{29.92}{(29.85)} & \left(\frac{30.00}{29.92} \right) \\ + & \frac{+7}{-8} & = & \frac{-8}{-8} \end{matrix}$				
9	TRUE ALTITUDE TEMPERATURE	+15	+15	+15					
10	IASCAS/EAS	130/132	140/142	130/129					
11	TRUE AIRSPEED	135	146	131	$\frac{\text{Temperature}}{\text{Pressure Altitude}} = \frac{\text{Drop Altitude}}{\text{(Corrected Drop Altitude)}}$ (ALTITUDE WINDOW)				
12	RATE OF FALL	17.4	26.2	20.0	$\frac{\text{Average Temperature}}{\text{Average Pressure Altitude}} = \frac{\text{(Adjusted Rate of Fall)}}{\text{Rate of Fall}}$ (DENSITY ALTITUDE WINDOW)				
13	ADJUSTED RATE OF FALL C	17.7	26.5	20.3	FORMULA				
14	ALTITUDE ABOVE POINT OF IMPACT D	820	670	400	True Altitude 1360 1210 960 Minus Point of Impact Elevation 540 540 560 (Altitude above Point of Impact) 820 670 400				
15	VERTICAL DISTANCE	-	180	540	370	$\frac{\text{Adjusted Rate of Fall}}{\text{Stabilization Altitude}} = \frac{1.0}{\text{(Time of Fall)}}$			
16	STABILIZATION ALTITUDE	640	130	30	$\frac{\text{Total Time of Fall}}{1.78 \text{ yds}/1.94 \text{ mtrs.}} = \frac{\text{(Drift Effect)}}{\text{Wind Speed}}$				
17	TIME OF FALL E	36.2	4.9	1.5	$\frac{\text{Groundspeed}}{1.78 \text{ yds}/1.94 \text{ mtrs.}} = \frac{\text{(Forward Travel Distance)}}{\text{Forward Travel Time}}$				
18	TIME OF FALL CONSTANT +	5.4	14.4	5.6	$\frac{\text{Groundspeed}}{1.78 \text{ yds}/1.94 \text{ mtrs.}} = \frac{\text{Distance}}{\text{(Time)}}$				
19	TOTAL TIME OF FALL	41.6	19.3	7.1	Usable DZ Remaining (PI to TE) 1200 500 600 Minus Safety Zone Distance 200 0 0 Usable Drop Zone Length 1000 500 600				
20	BALLISTIC WIND	250/10	190/10	120/10	D A T A				
21	DRIFT EFFECT F	234	109	40	SURFACE WIND 200/6 200/4 CALM				
22	DROP ALTITUDE WIND	250/15	190/20	120/15	MEAN EFFECTIVE WIND - 200/7 -				
23	MAG/TRUE COURSE	040	022	302	ALTITUDE WIND 250/10 230/15 180/4				
24	DRIFT CORRECTION	-3	+2	0	D R O P				
25	MAG/TRUE HEADING	037	024	302	BALLISTIC WIND USED (M) (I) I I I				
26	GROUND SPEED	148	165	146	GROUND SPEED (C) (D) (S) C 145 C 161 C 147				
27	EXIT TIME		4.6	4.2	DRIFT (C) (D) (S) C 3R C 0 C 1R				
28	DECELERATION QUOTIENT +		1.5	2.7	GREEN LIGHT TIME (S) (V) V S 11.9 V				
29	FORWARD TRAVEL TIME	3.2	6.1	6.9	RED LIGHT TIME 3 SEC 2 SEC 4 SEC				
30	FORWARD TRAVEL DISTANCE G	266	567	563	R E S U L T S				
31	STOP WATCH DISTANCE	269	173	375	TOT +.6 -.9 +1.1				
32	STOP WATCH TIME H	3.2	1.9	4.6	FORMATION POSITION (S) (V) V 1/1 S 1/2 V 1/2				
33	USABLE DROP ZONE LENGTH I	1000	500	600	RAW CIRCULAR ERROR 250/6 100/6 PI				
34	USABLE DROP ZONE TIME H	12.0	5.4	7.3	CORRECTED CIRCULAR ERROR 250/6 87/7 PI				
35	RED LIGHT TIME (32 PLUS 34)	15.2	7.3	11.9					

AF IMT 4018, 19980501, V2

Replaces AMC Form 512, Apr 93, which is obsolete.

4.3. Plotting Instructions. Using any DZ mosaic, plot the drift effect upwind from the PI. Plot the FTD back-track from the end of the drift effect vector, parallel to the run-in course. The end of this plot is the CARP. The reverse may also be used. Plot the FTD back along DZ run-in axis. Then plot the drift effect vector from the end of FTD vector. The end of this combined vector is the CARP (**Figure 4.12.**). [Attachment 2](#) details other means of plotting CARPs.

Figure 4.12. CARP Plotting Diagram.

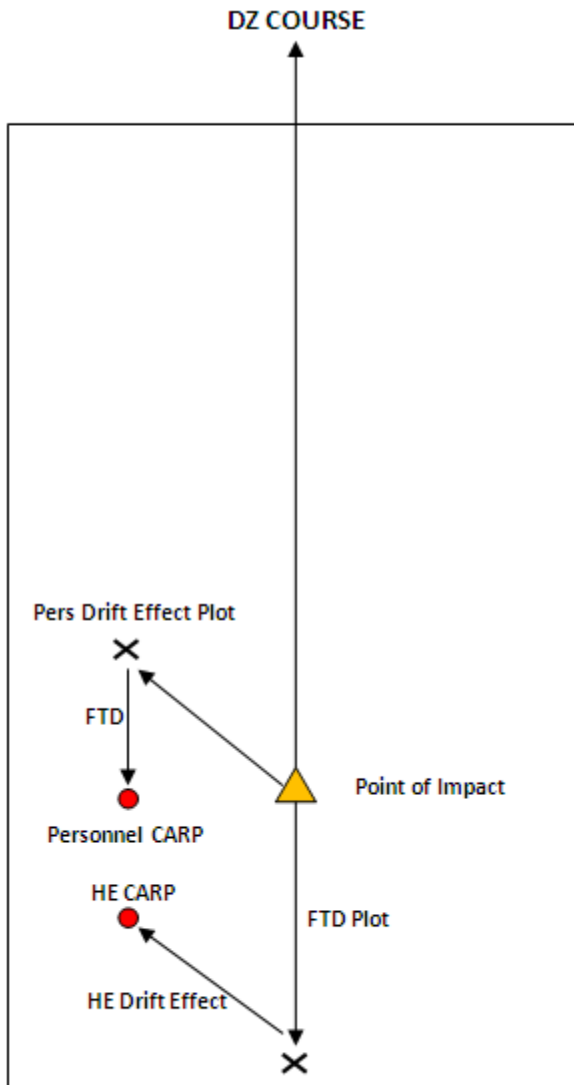

Chapter 5

HIGH ALTITUDE RELEASE POINT SOLUTIONS

5.1. General. High altitude airdrops are airdrops conducted above 3,000 feet AGL. The HARP solution is a basic CARP solution with the addition of a third (high-velocity or free fall) vector. High altitude drops are conducted with personnel High Altitude Low Opening (HALO), High-Altitude High-Opening (HAHO), or 2-stage equipment. CDS dropped at high altitude is commonly dropped using a high-velocity parachute to minimize exposure to wind drift. However, CDS may be dropped using HALO methods with a timer or barometrically actuated second-stage parachute release to further reduce exposure to wind drift. The primary method of planning a HARP is through MAJCOM-approved mission planning software (MPS). Aircrew will use approved MPS to calculate HARPs. **(T-3).** Navigators, CSOs, and aircraft commanders will verify the accuracy of all computer-generated products. **(T-3). Note:** The manual method for computing the HARP is the AF Form 4015, *High Altitude Release Point Computation*, where all requirements are solved using the MB-4 computer (whiz wheel). The formulas used in this chapter are based on use of the MB-4.

5.1.1. [Not applicable to AFSOC] During execution of C-17 and C-130J operations, computations are calculated in the MC. Parachute ballistic data is contained in a database within the MC. When necessary, this manual or MAJCOM-approved data can be manually entered when the parachute being used is not part of the MC database. Regardless of computation method, aircrew will brief all planned release points. **(T-3).**

5.1.2. Ram-air canopies that are not listed in this manual, Ballistics Tables or relevant flight crew information files (FCIF) but are listed in service approved lists (listed below), or approved by US Special Operations Command (USSOCOM), Joint Special Operations Command (JSOC), or other USSOCOM Component Fielding and Deployment Release are approved for use during HALO and HAHO operations. The jumping unit must be prepared to produce the applicable service AFUL or fielding and deployment release at the request of the aircrew. **(T-2).** Release procedures may be either jumpmaster directed or aircrew HARP. When conducting operations under the provisions of this paragraph, the jumpmaster shall inform the crew of the K-factor for the parachute(s) being used, aircrew and jumpmaster shall use the lowest performing parachute (largest K-factor) when calculating the release point and programming the mission computer. **(T-2).** In the absence of a published K-factors, aircrew and jumpmaster shall use MC-4 ballistics for release point computation and aircraft MC programming. **(T-2).** Approved service specific ballistic data can be found in the sources listed in the following paragraphs.

WARNING: Using a K-factor lower than what the parachute is capable of may result in jumpers landing off drop zone. Adhere to all individual service specific restrictions and limitations and all manufacturer parachute performance specifications and limitations.

5.1.2.1. Air Force AFUL, available online at <https://usaf.dps.mil/teams/AF-PPP/sitepages/approved%20for%20use%20list.aspx>

5.1.2.2. Naval Sea Systems Command Instruction (NAVSEAINST) 13512.1M, *Premeditated Personnel Parachuting and Cargo Airdrop Equipment Authorized for Navy Use*.

5.1.2.3. Headquarters Army Technical Bulletin (TB) 43-0001-80, *Personnel Parachute Authorized for Use List*.

5.1.2.4. US Army memorandum for record with interim authorization for personnel parachutes. Jumpmasters must supply aircrews with interim authorization memorandum for record prior to executing any airdrop involving a parachute on the interim authorization list. **(T-2)**.

5.1.2.5. The jumping unit must be prepared to produce the applicable Service AFUL or Fielding and Deployment Release at the request of the aircrew. If the jumping unit is unable to provide the ballistics for a chute listed in AFUL, or the ballistics are not listed in the AMC consolidated ballistic spreadsheet, then aircrew will use MC-4 ballistics for release point calculations. **(T-2)**.

5.1.2.6. Allied or partner nation AFUL. ATTLA hosts the allied or partner nation airdrop AFUL. Equipment and personnel systems listed in that document are approved for deployment from USAF MC-130H, C-130H, HC-130P, HC-130J, MC-130J, C-130J, C-130J-30, and C-17 aircraft in support of multinational airdrop. Approval to conduct the operation is the responsibility of the dropping MAJCOM and allied partner nation sponsoring organization. The allied or partner nation AFUL is available on ATTLA's website:

https://intelshare.intelink.gov/sites/attla/_layouts/15/start.aspx#/SitePages/Home.aspx.

5.2. Responsibilities. Aircrews are required to have a MC generated, manually computed, or solution from approved MPS for every high altitude airdrop. **(T-3)**. For multiple passes, aircrew will re-compute the HARP whenever drop altitude, actuation altitude, or significant wind changes occur. **(T-3)**.

5.2.1. In the event a parachutist cannot maneuver after exiting the aircraft (due to loss of visual ground references, injury, unconsciousness, or uncontrollable attitudes), or in the case of equipment delivery, an accurate HARP should ensure the load arrives in the vicinity of the intended PI. When dropping personnel or guided equipment and/or supplies, this paragraph does not preclude using the launch acceptability region (LAR) as specified in **paragraph 5.7.5** to conduct the drop.

5.2.2. Although an experienced parachutist can maneuver approximately 500 feet horizontally for each 1000 feet of free fall, this capability is not factored as part of the HARP. As a result, the HARP can help ensure the parachutist arrives in the vicinity of the intended PI in the event he cannot maneuver after exiting the aircraft (due to loss of visual ground references, injury, unconsciousness, or uncontrollable attitudes). Reference **paragraph 5.7.5** to factor in parachute forward drive.

5.2.3. Due to the altitudes involved in these types of airdrops, visual methods of directing the aircraft to the HARP are normally less accurate than other electronic methods. These electronic methods include INS, aircraft MC, GPS, and radar. All of these systems still require use of HARP computations, but they generally lead to better results. If the objective area or surrounding area is obscured, there may be no way to visually direct the aircraft toward the computed release point or for the jumpers to visually steer towards the PI. Operational procedures and directives may require use of these systems for high altitude deliveries.

5.3. Equipment.

5.3.1. Personnel.

5.3.1.1. Parachute system. The standard free fall parachute system consists of a main pack and canopy, reserve pack and canopy, and harness. The canopy design is similar to an aircraft's wings, with curved upper surfaces (top skin) and flat lower surfaces. This design is known as ram air parachute system (RAPS) or commonly referred to as "square parachutes." Examples of RAPS include the MC-4, MC-5, MS-360, MP-360, and HG-380. The last three digits of the RAPS usually refer to the square footage of the canopy (360 sq. ft on the MS-360 and 380 sq. ft on the HG-380). The large surface area of RAPS provide considerable maneuverability and forward speed. The RAPS utilize an inflated airfoil design, which allows it to glide in a controlled direction. The jumper operates hand controls that allow turns and altitude changes. Aircrew will coordinate with the jumpmaster to determine which chute (main or reserve) to use to calculate the HARP. **(T-3)**. Typically, the reserve parachute has worse performance characteristics than the main. Regardless of which chute is used to calculate the HARP, proper planning, risk assessment, and acceptance shall be conducted by the supported unit. **(T-0)**. This planning will include map or imagery study of release point, projected canopy flight path, potential hazards or obstacles, and identification of alternate landing areas. **(T-2)**. Any adjustment to the HARP required as a result of this assessment will be briefed to the aircrew by the jumpmaster. **(T-3)**. The supported unit accepts responsibility for the adjusted HARP. Crews shall use the K-Factor for the lowest performing parachute (largest K-Factor) when calculating the HARP. **(T-2)**.

5.3.1.2. Non-tactical ram-air parachute systems (NTRAPS). NTRAPS, formerly known in the USAF as advanced parachute systems (APS), is the military designation given to civilian parachutes when used in military aircraft. When dropping NTRAPS crews will use MC-4 ballistics. **(T-2)**. See AFI 10-3503, *Personnel Parachute Program*, for more information on NTRAPS.

5.3.1.3. Activation devices. An electronic automatic activation device (EAAD) such as the military Cybernetic Parachute Release System (CYPRES) is incorporated into the assembly to automatically activate the reserve parachute in case of emergency. This release allows automatic actuation down to a pre-set altitude (usually 1500-feet). Depending on the unit, other EAADs with different characteristics may be used. Jumpmasters will have the characteristics of the EAAD being used. **(T-2)**. Aircrew and jumpmasters will coordinate enroute flight time, intermediate terrain adjustments, forecast DZ altimeter setting, and EAAD settings or calculations. **(T-3)**. If available, the jumpmaster should receive an update of the local altimeter setting for the planned DZ from the aircrew at the 10-minute advisory. Manual ripcord actuation is the normal procedure. For more detailed information on DOD approved automatic activation devices refer to Army Techniques Publication (ATP) 3-18.11, *Special Forces Military Free-Fall Operations*, and TM 70244A-OI/A, *U.S. Marine Corps Military Freefall Operations*.

5.3.1.4. Other. Services are authorized to use equipment that is on their service AFUL on USAF aircraft. See [paragraph 5.1.2](#) with regard to use of non-standard parachute systems and for a list of service AFULs.

5.3.1.5. **(Added-AFSOC)** A form of high-altitude airdrop that utilizes a static line for chute actuation is called Double-Bag Static Line (DBSL). This procedure allows the jumpers to stay consolidated longer, increasing the likelihood of the jumpers landing together. Crews should use HAHO procedures for all DBSL airdrops unless mission computer limitations do not allow. Proper ballistics are provided by ATTLA in the Approved Consolidated Personnel Ballistic document mentioned in [paragraph 1.3.1](#). **(T-2)**

5.3.2. HALO CDS. To minimize the bundle impact of longer fall times, high-velocity parachutes are employed, providing less wind drift and more reliable ballistic profiles. However, high-velocity bundle impact speeds are much higher, increasing the likelihood of damage to bundle contents. HALO CDS allows for high altitude drops with low-velocity impacts, as the bundles fall under a high-velocity parachute and transition to a low-velocity parachute near the end of the fall sequence. These bundles descend at approximately 80-150 feet per second and at a predetermined altitude the high-velocity portion uses an automatic opening device (AOD) to transition to a low-velocity parachute which decelerates the bundle to impact velocity to approximately 28 feet or less per second. This method mitigates the effect of wind on the bundle. The presence of two different size parachutes and an AOD are used on HALO CDS. HALO CDS is not widely used but the aircrew must verify that an AOD staging device is being used. **(T-2)**.

5.4. Basic Assumptions.

5.4.1. Deployment altitude. The deployment altitude obtained from the jumpmaster is considered to be the altitude where full parachute deployment occurs and a constant rate of descent is established. Actuation altitude (for manual ripcord pull) is commonly approximated to be 500 feet above the deployment altitude. A more accurate calculation can be determined by using the deceleration distance (DD) from the parachute ballistic data. The DD is the altitude lost from actuation of the parachute to full deployment. The aircrew member should confirm which altitude, deployment or actuation, corresponds to the desired altitude received from the jumpmaster.

5.4.2. Standard units. The standard unit of measurement for all ground distances is meters for HALO and nautical miles (NM) for HAHO. A common technique is to maintain meters throughout all formulas and calculations and then converting meters into yards or nautical miles as the final step of the calculation. Conversion formulas are found on the bottom of the AF Form 4015. Formulas E-H on the AF Form 4015 all use 1.94 as a conversion factor which provides distances in meters.

5.5. Altitudes and Altimeters.

5.5.1. Altitudes. Pressure altitude or indicated true altitude is used as the aircraft drop altitude reference. Aircrew must convert drop altitude and actuation altitude to absolute altitudes for HARP computations. **(T-2)**. Indicated altitude is the altitude to be flown with an externally supplied (surface) DZ altimeter setting. Pressure altitude is the altitude to be flown with an altimeter setting of 29.92.

5.5.2. Altimeters. The high-altitude parachutist typically use the MA-10 or MA2-30 series altimeter. These adjustable altimeters can be set to display altitudes with respect to PI

elevation. This enables the parachutist to normally activate their own parachute, based on indicated altitude AGL. **CAUTION:** Some altimeters cannot override pressurization.

5.5.3. Actuation devices. Jumper EAADs are activated in part by the rapid change in pressure altitude during freefall. When EAADs are used, aircrew must ensure that all aircraft pressurization changes are coordinated with the jumpmaster to ensure that EAADs are not inadvertently actuated. **(T-2)**. Specifically, rapid pressurization and/or rapid descents while the aircraft is unpressurized may cause the EAAD to actuate.

5.6. Ballistic Wind Determination.

5.6.1. Calculating a ballistic wind. In accordance with AFPAM 11-216, if wind directions are fairly close together, a satisfactory average wind can be determined by arithmetically averaging the wind directions and wind speeds. However, the greater the variation in wind direction, the less accurate the result is. It is generally accepted that winds should not be averaged arithmetically if the difference in directions exceeds 90 degrees and/or the speed differs by more than 15 knots. In these cases, the wind should be averaged vectorially using the wind face and square grid portion of the MB-4 computer. Keep in mind that the 90 degree/15 knot difference in winds is not between each wind to be averaged, but the total difference between the first and last winds.

5.6.2. Weather support. Normally, the weather forecaster is not trained to calculate the vectorial average of winds, therefore, the aircrew member should request winds at the needed altitudes and compute the average. The Air Force Weather Agency (AFWA) has wind information available at:

https://weather.af.mil/AFW_WEBS/ or https://weather.af.smil.mil/AFW_WEBS/ for SIPRNet.

5.6.3. Types of ballistic wind. Depending on the type of drop being performed, aircrew must calculate several ballistic winds. **(T-3)**.

5.6.3.1. High velocity ballistic wind. During personnel freefall or the first stage of a 2-stage equipment drop, aircrew must calculate high velocity ballistic wind in order to determine the high velocity drift effect on the object. **(T-3)**. Winds should be accounted for at least every 2,000 feet from stabilization altitude down to (but not including) actuation altitude, since that is where free-fall stops. Use of closer wind intervals results in a more accurate release point.

5.6.3.2. Deployed ballistic wind. The deployed ballistic wind is calculated from actuation altitude, or the second stage of a 2-stage equipment drop, in order to determine the deployed drift effect on the object. Winds should be accounted for every 1,000 feet from actuation altitude, or aircraft exit altitude in the case of static line parachute deployment, down to the surface.

5.7. HARP Principles. High altitude airdrops consist of similar components when compared to a traditional CARP, **Figure 5.1.** and **Figure 5.2.**

5.7.1. HALO principles. HALO operations are jumps made with an exit altitude of up to 35,000 feet MSL and a parachute deployment altitude at or below 6,000 feet AGL. HALO infiltrations are the preferred military free fall (MFF) method of infiltration when the enemy air defense posture is not a viable threat to the infiltration platform. HALO computations are

based upon the wind drift of the canopy and do not account for the forward drive characteristics of the parachutes. Following deployment, parachutists spiral over the objective area until final approach and landing.

5.7.2. HAHO Principles. HAHO operations are standoff infiltration jumps made with an exit altitude of up to 35,000 feet MSL and a parachute deployment altitude at or above 6,000 feet AGL. HAHO infiltrations are the preferred method of infiltration when the enemy air defense threat is viable or when a low signature infiltration is needed. Standoff HAHO infiltrations provide commanders a means to drop MFF parachutists outside the air defense umbrella, where they can navigate undetected under canopy to the DZ or objective area. Mission planners can utilize the maximum standoff capability of HAHO drops to mask the actual objective area from the enemy. In addition to the wind drift of the canopy, HAHO calculations utilize the forward drive of the parachute. The HAHO HARP is designed to deliver the parachutists to a point where they arrive over the objective area at 1,000 feet AGL to perform one final approach and landing.

Note: Some jumpmasters refer to both HALO and HAHO as MFF jumps. When calculating the HARP, aircrew will clarify if there is a period of planned free-fall. **(T-3)**.

5.7.3. High altitude equipment principle. High-altitude equipment airdrops have similarities of HALO and HAHO airdrops. A single-stage high-altitude equipment airdrop commonly consists of a load rigged with a stabilizing, high-velocity or reefed parachute that allows the load to descend at approximately 65-250 feet per second that is actuated immediately upon exiting the aircraft, giving these types of airdrops similar vectors as a HAHO drop (single RoF all the way to the ground). Two-stage equipment airdrops commonly consist of a high-velocity parachute portion, followed by the activation of a larger canopy to slow the descent as the load approaches the ground. This gives two-stage equipment airdrops similar vectors as a traditional HALO drop (two different rates of fall). The JPADS is also considered a high-altitude CDS operation. The primary difference between JPADS and traditional CDS is the GPS guided gliding capability of JPADS. HAHO and HALO methods are used to determine the HARP for JPADS, however, this manual does not provide a manual HARP calculation method or ballistics for JPADS. The JPADS HARP is exclusively calculated using software.

5.7.4. HARP Vectors. The HARP is a basic CARP solution with a provision for an additional free fall or high velocity vector. The HARP is computed using the AF Form 4015. Mission planners or aircrew must evaluate each mission to determine which portions of the HARP are required, and thus, which portions of the AF Form 4015 are needed. **(T-3)**.

5.7.5. LAR. A LAR is created to account for the ability of modern RAPS to drive considerable distances, even in no-wind situations. A LAR also recognizes the ability of a MFF parachutist to be dropped within a large area and maneuver to a DZ. Within the LAR, it is possible for the jumper to exit the aircraft and reach the objective area. Additionally, the LAR provides flexibility to mission planners when tactics, terrain, or airspace preclude aircrew from driving to the exact calculated HARP location. On a HALO calculation forward drive is not used to calculate the HARP, but is used to calculate the deployed drive distance (DDD) which in turn defines the LAR. LARs can be used for both HALO and HAHO airdrops, however, aircrew will use the calculated release point as the primary HARP location. **(T-3)**. Although the HARP should be the primary location for release, drops may be conducted anywhere within the confines of the LAR as long as it is agreed upon with the jumpmaster.

5.7.5. (AFSOC) AFSOC aircrews will compute a Launch Acceptability Region (LAR) for all MFF airdrops. Aircrews whose aircraft mission computers cannot create one, will use the Launch Acceptability Region (LAR) Calculator, XDROP, or HARP calculation software published by FCIF to conduct MFF airdrops. The LAR provides the crew and jumpers with a realistic usable drop zone time for MFF airdrops based on parachute performance, rather than drop zone size.

5.7.6. Green light timing. Usable DZ time for static line personnel airdrops are based on DZ length (see [paragraph 4.2.33](#)). However, in accordance with AFI 13-217 DZ, size for MFF airdrops is at the discretion of the jumpmaster. MFF airdrops are routinely conducted to very small DZs where a green light time based on DZ length unnecessarily limits the release time available to MFF jumpers. Therefore, green light time for MFF airdrops (both crew-directed and jumpmaster-directed) shall be based on the amount of time it takes the aircraft to traverse the computed LAR. (T-3).

5.7.6.1. During crew-directed MFF airdrops, crews may turn on the green light at the computed release point or at the point requested by the user, provided it falls within the LAR. (T-2).

5.7.6.2. During jumpmaster-directed MFF airdrops, crews may turn on the green light upon entering the leading edge of the LAR or as coordinated with the jumpmaster. The jumpmaster is responsible for accuracy when jumpmaster-directed release procedures are used. (T-2).

5.7.6.3. During all MFF airdrops, once the green light is on, crews may delay turning on the red light until they reach the trailing edge of the updated LAR.

WARNING: Dropping at the edge of the LAR puts the parachutists and/or cargo at their maximum theoretical drive distance. In the interest of safety, a percentage of the computed parachute drive distance should be used. For training, consider using a safety factor (SF) of 80% to account for jumper proficiency, DZ size, and non-uniform winds. For contingency, the jumpmaster is responsible for specifying the SF utilized for the airdrop.

5.7.6.3. (AFSOC) **WARNING:** If both an adjusted LAR radius, safety factor, and/or a reduced percentage of the ballistic wind velocity are used, aircrews must be aware of high winds from drop altitude to the surface. Applying both values may place the HARP (the jumper) too close to the PI at too high an altitude to overcome the parachute drift due to wind effects. (T-2)

5.7.6.4. SF or safety percentage (SP). On HAHO calculated releases, jumpmasters may request a SF to provide a buffer area to permit the parachutists to assemble under canopy and establish a landing pattern over the DZ. The typical SF is 1,000 feet for assembly and 1,000 feet for approach and landing for a total of 2,000 feet. This means, on a perfectly calculated HARP, parachutists would overfly the DZ at an altitude of 1,000 feet before initiating their landing pattern. To provide for an additional level of safety, a SP may be used. The SP is used to reduce the DDD of the parachute (typically by 80%) to account for jumper proficiency, DZ size, and non-uniform winds. Ultimately, the jumpmaster is responsible for specifying the SF and SP.

WARNING: Jumpmasters may request an additional 1,000 feet to be included into the SF to decrease the distance of the HARP for training for a total of 3,000 feet. This means that if

parachutists do not initiate actions to account for the closer release to the DZ (doglegs, or s-turns), they should arrive over the DZ at 2,000 feet AGL, which can be hazardous at high winds. Should jumpmasters request a SF of 3,000 feet, it is unwise to use a SP in addition to the 3,000 foot SF because in a moderate to high wind situation parachutists could have a high potential to be blown downwind of the DZ. Ultimately, jumpmasters are responsible for the SF or SP used.

5.7.6.4. **(AFSOC) WARNING:** If both an adjusted LAR radius, safety factor, and/or a reduced percentage of the ballistic wind velocity are used, aircrews must be aware of high winds from drop altitude to the surface. Applying both values may place the HARP (the jumper) too close to the PI at too high an altitude to overcome the parachute drift due to wind effects. **(T-2)**

Figure 5.1. HALO HARP Diagram.

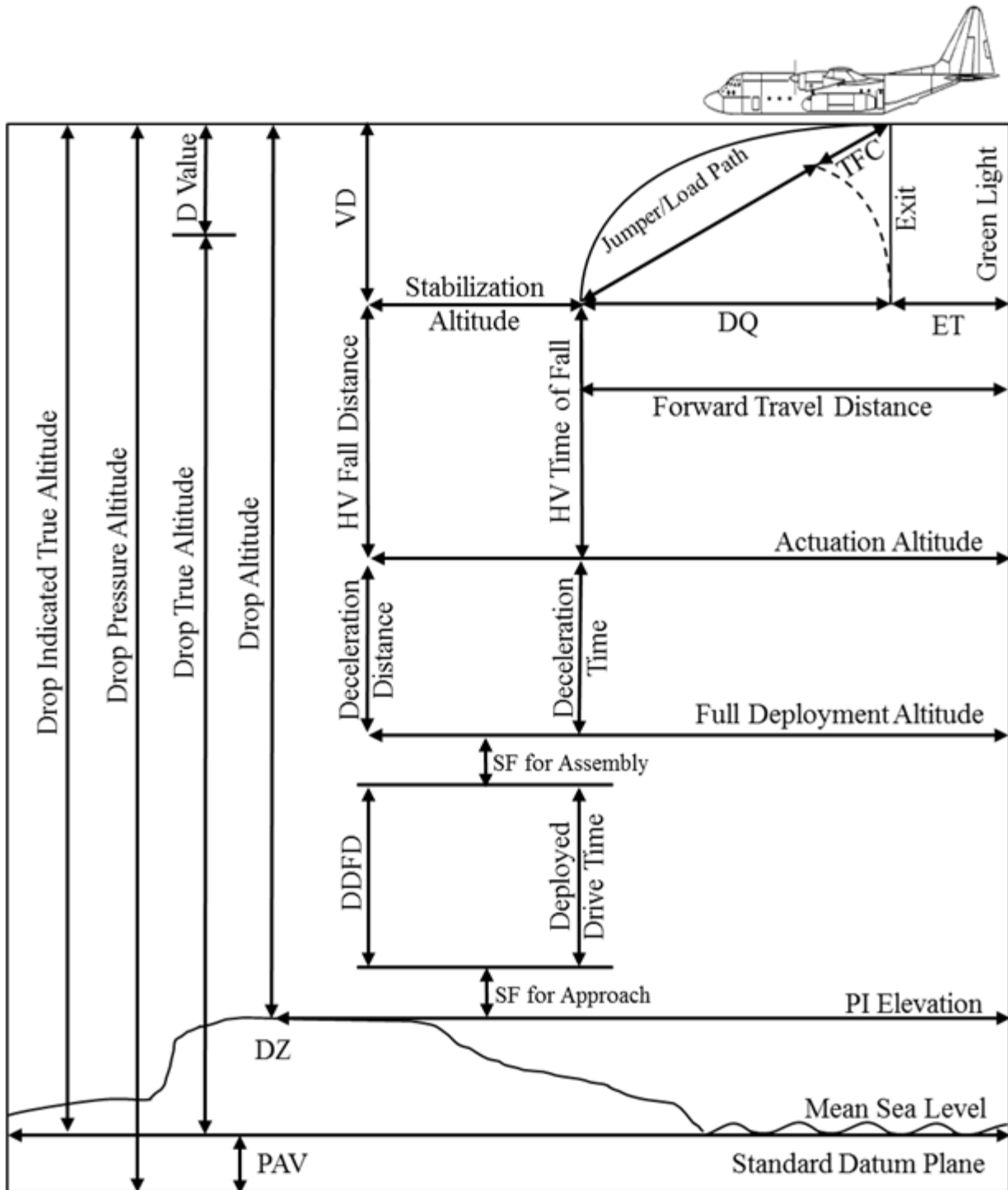
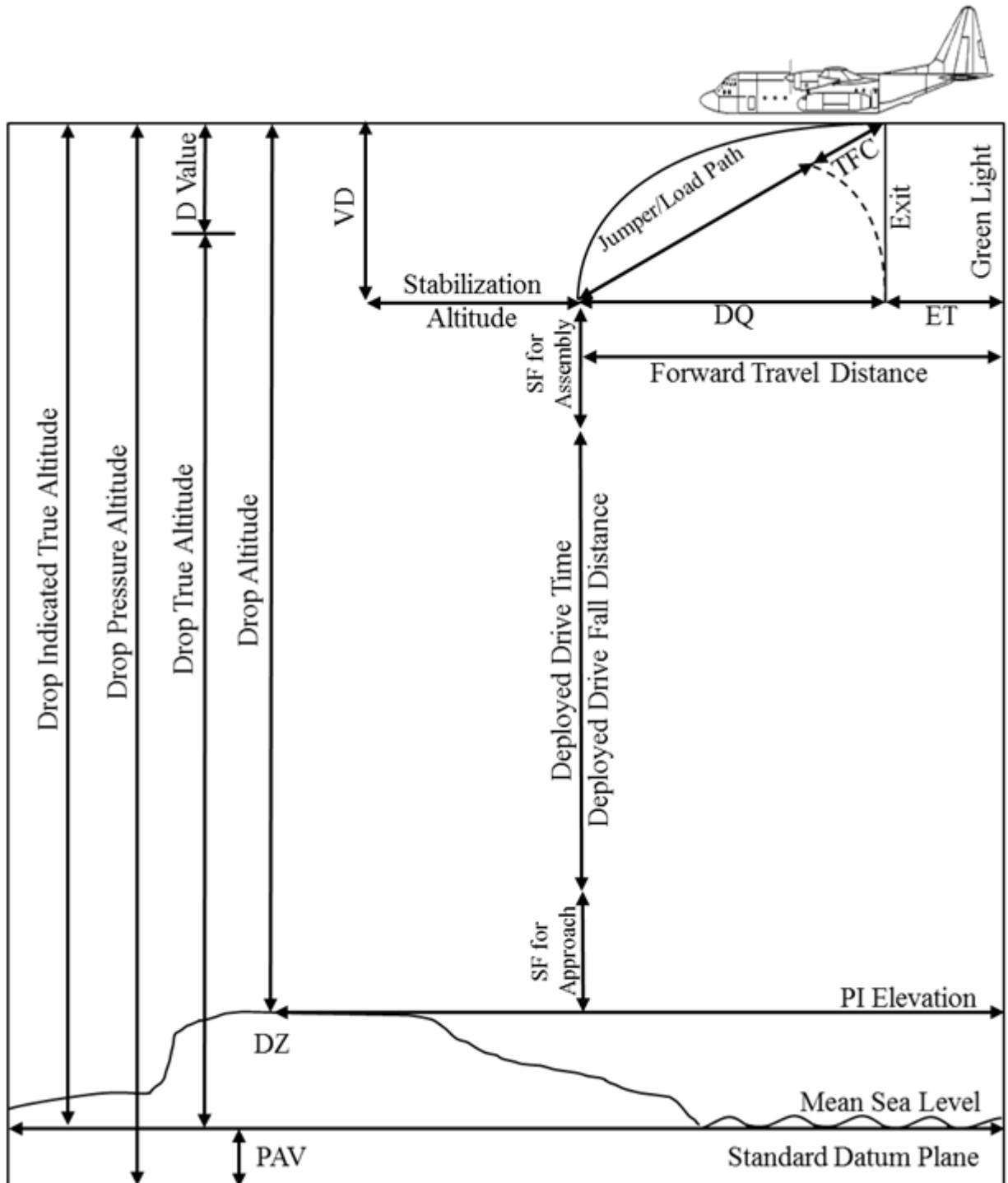

Figure 5.2. HAHO HARP Diagram.



5.8. Completion of the AF Form 4015. The AF Form 4015 has been significantly revised and merged with the AF Form 4017. AF Form 4017 is now obsolete. The following calculation method is for use by aircrew navigators and requires a MB-4 computer (whiz wheel). This method is also intended to be an outline for computer based calculation methods. All types of high-altitude airdrops can be manually calculated using this worksheet and the following procedures:

5.8.1. Item 1. Drop indicated true altitude. Altitude, in feet above mean sea level, to be flown with the DZ altimeter setting in the barometric scale of the pressure altimeter.

5.8.2. Item 2. PAV. Pressure difference, in feet, between mean sea level and the standard datum plane. The PAV is computed using the DZ altimeter setting. If the DZ altimeter setting is greater than 29.92, the PAV is subtracted from the indicated true altitude to obtain pressure altitude. The PAV is added when the altimeter setting is less than 29.92 (compute using Formula A in AF Form 4015).

5.8.3. Item 3. Drop pressure altitude. Drop altitude, in feet above the standard datum plane. The altitude to be flown with 29.92 set in the pressure altimeter. Item 1 plus Item 2.

5.8.4. Item 4. “D” value. The difference, in feet, between the true altitude of the aircraft and the pressure altitude of the aircraft. The “D” is obtained from the weather forecaster or can be measured enroute by radar altitude plus terrain elevation minus pressure altitude.

5.8.5. Item 5. Drop true altitude. Altitude, in feet above mean sea level. Item 3 plus item 4. To verify forecast “D” values, or if a “D” value cannot be obtained, drop true altitude may be approximated by using the ALTITUDE COMPUTATIONS window of the MB-4 computer and the formula in [Figure 5.3](#).

Figure 5.3. Drop True Altitude Formula.

$$\frac{\text{Drop Altitude Temperature}^{**}}{\text{Drop Pressure Altitude (Item 3)}} = \frac{\text{(Drop True Altitude)}}{\text{Indicated True Altitude (Item 1)}^*}$$

* Drop pressure altitude is placed on the outer edge of the MB-4 and Indicated True Altitude is read on the inner wheel.

** Drop altitude temperature is temperature in degrees Celsius at drop altitude.

5.8.6. Item 6. PI elevation. MSL elevation, in feet, of the PI.

5.8.7. Item 7. Drop absolute altitude. Absolute altitude, in feet, above the PI (Item 5 minus Item 6)

5.8.8. Item 8. VD. Distance, in feet, the load or parachutist descends after exiting the aircraft until reaching a stabilized condition. Obtain from parachute ballistic data.

5.8.9. Item 9. Stabilization altitude. Item 7 minus Item 8, in feet AGL.

5.8.10. Item 10. PI pressure altitude. Item 6 plus Item 2, in feet MSL.

5.8.11. Actuation altitudes (For HALO only).

5.8.11.1. Item 11a. Actuation indicated altitude (ft AGL). Actuation altitude, in feet above ground level, intended by the jumper.

5.8.11.2. Item 11b. Actuation indicated true altitude (ft MSL). Uncorrected actuation altitude, in feet above mean sea level. Item 11a plus Item 6.

5.8.11.3. Item 11c. Actuation pressure altitude. Pressure altitude, in feet MSL, where actuation occurs. Calculate using Formula B in the ALTITUDE COMPUTATIONS window of the MB-4 computer. See [Figure 5.4](#).

Figure 5.4. Actuation Pressure Altitude Formula.

$$\frac{\text{Actuation Altitude Temperature}^{**}}{(\text{Actuation Pressure Altitude})} = \frac{\text{Actuation Indicated Altitude (Item 11a)}}{\text{Actuation Indicated True Altitude MSL (Item 11b)}^*}$$

* Actuation indicated altitude is placed on the outer edge of the MB-4. Actuation indicated true altitude is read on the inner wheel.

** Actuation altitude temperature is obtained from weather tables.

5.8.11.4. Item 11d. Absolute actuation altitude. Altitude in feet, above ground level where actuation occurs. Compute on the DR computer using the ALTITUDE COMPUTATIONS window and the formula in [Figure 5.5](#).

Figure 5.5. Absolute Actuation Altitude Formula.

$$\frac{\text{Act Alt Temp (item 28)}}{\text{Act Press Alt (item 11c)}} = \frac{(\text{Abs Act Alt})}{\text{Act Ind Alt (item 11a)}}$$

5.8.12. Item 12. High velocity fall distance (HVFD). Distance, in feet, the parachutist or load descends from stabilization altitude (Item 9) to absolute actuation altitude (Item 11d) of the personnel parachute or second stage recovery system (for equipment airdrops). Item 9 minus Item 11d. Zero for HAHO.

5.8.13. Item 13. High velocity rate of fall. Sea level, standard day RoF of free falling parachutist. Obtained from parachute ballistic data. Not applicable for HAHO.

5.8.14. Item 14. High velocity average temperature. Temperature, in degrees Celsius, used to compute adjusted RoF. Compute by averaging drop altitude and actuation altitude temperatures. Not applicable for HAHO.

5.8.15. Item 15. High velocity mid-pressure altitude (HVMPA). The average pressure altitude used to compute the adjusted RoF. Not applicable for HAHO. Compute using the formula in [Figure 5.6](#).

Figure 5.6. High Velocity Mid-Pressure Altitude Formula.

$$\text{HVMPA} = \frac{\text{Item 3-Item 8+Item 11c}}{2}$$

5.8.16. Item 16. High velocity adjusted rate of fall (HV ARoF). High velocity RoF, in feet per second, corrected for air density. Not applicable for HAHO. Compute on the MB-4 computer using the DENSITY ALTITUDE COMPUTATION window and Formula C. See [Figure 5.7](#).

Figure 5.7. High Velocity Adjusted Rate of Fall Formula.

$$\frac{\text{HV Average Temp. (Item 14)}}{\text{HVMPA (Item 15)}} = \frac{(\text{HV ARoF})}{\text{HV Rate of Fall (Item 13)}^*}$$

* HV ARoF is read on the outer wheel of the MB-4 and high velocity RoF is read on the inner wheel.

5.8.17. Item 17. High velocity time of fall. Elapsed time, in seconds, from stabilization altitude until actuation altitude. Zero for HAHO. Compute using the Formula D. See [Figure 5.8](#).

Figure 5.8. High Velocity Time of Fall Formula.

$$\frac{\text{HV ARoF (Item 16)}}{\text{HV Fall Distance (Item 12)}} = \frac{1.0}{\text{(HV Time of Fall)}}$$

5.8.18. Item 18. TFC. A time constant in seconds used to determine drift effect during the time the parachutist or load falls after exiting the aircraft until reaching the stabilization altitude. TFC is usually extracted from the parachute ballistic data.

5.8.19. Item 19. High velocity total time of fall. Time, in seconds, from parachutist or load exiting the aircraft until reaching actuation altitude (or ground level for single-stage equipment airdrops). Obtain by adding Item 17 and Item 18.

5.8.20. Item 20. High velocity ballistic wind (HVBW). Average wind, in knots, affecting the parachutist or load from stabilization to actuation. Compute using procedures in [paragraph 5.6.3](#).

5.8.21. Item 21. High velocity drift effect (HVDE). Total drift in meters incurred by the parachutist or load while descending from drop altitude to actuation altitude. Compute using the formula in [Figure 5.9](#).

Figure 5.9. High Velocity Drift Effect Formula.

$$\frac{\text{HV Total Time of Fall (Item 19)}}{1.94} = \frac{\text{(HV Drift Effect)}}{\text{HV Ballistic Wind Speed (Item 20)}}$$

5.8.22. Item 22. Actuation indicated altitude (ft AGL). Actuation altitude, in feet above ground level, intended by the jumper.

5.8.23. DD and deceleration time (DT).

5.8.23.1. Item 23a. DD. VD, in feet, the parachutist or load falls from staging system actuation until full deployment of the recovery parachute(s). Obtain from parachute ballistic data. Some timers can be set to utilize a 0-13 second delay upon reaching the actuation altitude. It is necessary to convert the selected delay to altitude lost during the delay period. Add this distance to the DD extracted from the ballistic data. Not applicable for HAHO. To determine altitude lost use the formula in [Figure 5.10](#).

Figure 5.10. Delay Distance Formula.

$$\frac{\text{HV ARoF (Item 16)}}{\text{(Delay Distance)}} = \frac{1.0}{\text{Delay Time}}$$

5.8.23.2. Item 23b. DT. Elapsed time, in seconds, from actuation of the staging system to deployment of the recovery parachute(s). Obtain from ballistic data. When using a time delayed activation device, add the number of seconds delay. This block is needed simply for input into the aircraft MC, as the DD is previously accounted for. Not applicable for HAHO.

5.8.24. Item 24. Safety Factor. The safety factor, in feet, which provides a buffer area after jumper exit to permit the parachutists to assemble under canopy and to establish the landing pattern and approach over the DZ. Common SFs are a thousand feet for assembly and one to two thousand feet for the approach to landing. It is abbreviated 'SF' in formulas and the units of measurement are in feet. The jumpmaster is responsible for specifying the SF.

5.8.24. (AFSOC) WARNING: If both an adjusted LAR radius, safety factor, and/or a reduced percentage of the ballistic wind velocity are used, aircrews must be aware of high winds from drop altitude to the surface. Applying both values may place the HARP (the jumper) too close to the PI, at too high an altitude to overcome the parachute drift due to wind effects. (T-2)

5.8.25. Item 25. Full deployment altitude (FDA). Altitude, in feet AGL, where full parachute deployment occurs and a constant rate of descent is established. For HALO Item 11a minus Item 23a. For HAHO and static line, equal to Item 9.

5.8.26. Item 26. Deployed drive fall distance (DDFD). Altitude, in feet AGL, where full parachute deployment occurs and a constant rate of descent is established minus SF. Item 25 minus Item 24.

5.8.27. Item 27. Deployed RoF. Sea level, standard day RoF, in feet per second obtained from parachute ballistic data.

5.8.28. Item 28. Deployed average temperature. Temperature, in degrees Celsius, used to compute deployed adjusted RoF. Compute by averaging surface temperature and deployment altitude temperature.

5.8.29. Item 29. Deployed mid-pressure altitude (DMPA). Average altitude, in feet, used to compute the deployed adjusted RoF. This altitude is the actuation pressure altitude (Item 11c) minus DD (Item 23a) plus the PI pressure altitude (Item 10) with the sum divided by two. See [Figure 5.11](#).

Figure 5.11. Deployed Mid-Pressure Altitude Formula.

$$DMPA = \frac{\text{Item 11c} - \text{Item 23a} + \text{Item 10}}{2}$$

5.8.30. Item 30. Deployed adjusted rate of fall (DARoF). Deployed RoF, in feet per second, corrected for air density. Compute on the MB-4 computer using the density altitude computations window and the Formula C. See [Figure 5.12](#).

Figure 5.12. Deployed Adjusted Rate of Fall Formula.

$$\frac{\text{Deployed Average Temperature (Item 28)}}{DMPA \text{ (Item 29)}} = \frac{DARoF}{\text{Deployed RoF (Item 27)}^*}$$

* DARoF is read on the outer wheel of the MB-4 and the deployed RoF is read on the inner wheel.

5.8.31. Item 31. Total deployed time (TDT). Elapsed time, in seconds, from full deployment altitude until the parachutist or load reaches ground level. Compute using the formula in [Figure 5.13](#).

Figure 5.13. Total Deployed Time Formula.

$$\frac{\text{DARoF (Item 30)}}{\text{FDA (Item 25)}} = \frac{1.0}{(\text{Total Deployed Time})}$$

5.8.32. Item 32. Deployed drive time (DDT). Elapsed time, in seconds, to traverse the DDFD. Compute using the formula in [Figure 5.14](#).

Figure 5.14. Deployed Drive Time Formula.

$$\frac{\text{DARoF (Item 30)}}{\text{DDFD (Item 26)}} = \frac{1.0}{(\text{Deployed Drive Time})}$$

5.8.33. Item 33. Deployed ballistic wind (DBW). Average magnetic wind, in knots, affecting the parachutist or load from actuation altitude, or aircraft exit altitude for static line operations to the ground. Compute using the procedures in [paragraph 5.6.3](#).

5.8.33. (AFSOC) WARNING: If both an adjusted LAR radius, safety factor, and/or a reduced percentage of the ballistic wind velocity are used, aircrews must be aware of high winds from drop altitude to the surface. Applying both values may place the HARP (the jumper) too close to the PI at too high an altitude to overcome the parachute drift due to wind effects. (T-2)

5.8.34. Item 34. Deployed wind effect (DWE). Total drift, in meters, incurred by the parachutist or load during the descent from deployment altitude to the ground. See [Figure 5.15](#).

Figure 5.15. Deployed Wind Effect Formula.

$$\frac{\text{Total Deployed Time (Item 31)}}{1.94} = \frac{(\text{Deployed Wind Effect})}{\text{Deployed Ballistic Wind (Item 33)}}$$

Note: If there is a significant change in wind direction (i.e., a wind shear), it may be necessary to compute the wind drift as two rather than one vector. Should this occur, inform the jumpmaster of where the shear occurs.

5.8.35. Item 35. Parachute forward drive (FD). The forward drive at sea level, in knots, capable by the deployed chute. Obtained from parachute ballistic data.

5.8.36. Item 36. Deployed drive distance (DDD). Maximum distance, in meters, that the fully deployed parachute can drive during the deployed drive time due solely to the forward drive of the parachute (i.e., no wind effect). This is also the maximum LAR radius. See [Figure 5.16](#).

Figure 5.16. Deployed Drive Time Formula.

$$\frac{\text{Deployed Drive Time (Item 32)}}{1.94} = \frac{\text{DDD (Item 36)}}{\text{FD (Item 35)}}$$

5.8.37. Item 37. Total wind effect (TWE). Total distance, in meters, that the parachute or load travels by the effects of the wind. Item 21 plus Item 34.

5.8.38. Item 38. Indicated/Calibrated/Equivalent/True Airspeed. Aircraft will drop using the type and specified airspeed in operational regulations. (T-2). Regardless of the type of

airspeed used as an entering argument, aircrew must calculate TAS for use in determining aircraft groundspeed (Item 43). **(T-3)**. See AFPAM 11-216 for methods of computing CAS, EAS, or TAS.

5.8.39. Item 39. Drop altitude wind. Forecast or in-flight wind, in magnetic, which dictates or affects the heading of the aircraft at release, FTD, and the timing problem.

5.8.40. Item 40. Magnetic course. Magnetic course to be flown at time of load release. Obtain from planning sheet or DZ survey.

5.8.41. Item 41. Drift correction. Calculated on the MB-4 using drop altitude wind, TAS, and magnetic course.

5.8.42. Item 42. Magnetic heading. Magnetic heading to be flown at time of load release.

5.8.43. Item 43. Ground speed (GS). Preflight or actual groundspeed calculated in knots.

5.8.44. Item 44. ET. Elapsed time, in seconds, from “green light” until the parachutist or load exits the aircraft. Obtained from parachute ballistic data.

5.8.45. Item 45. DQ. A constant in seconds during airdrop tests that compensates for the nonlinear deceleration in forward speed of an airdrop item as it approaches stabilization. Obtained from parachute ballistic data.

5.8.46. Item 46. FTT. ET plus deceleration quotient. Item 44 plus Item 45.

5.8.47. Item 47. FTD. Ground distance in meters along track the parachutist or load travels after "Green Light" until the forward momentum has stopped and the load begins drifting under parachute canopy. Compute using the formula in [Figure 5.17](#).

Figure 5.17. Forward Travel Distance Formula.

$$\frac{\text{Ground Speed (Item 43)}}{1.94} = \frac{\text{FTD (Item 47)}}{\text{FTT (Item 46)}}$$

5.8.48. Item 48. Stopwatch distance. Ground distance, in meters, measured on the DZ depiction from a ground reference point, or from an electronic aid, down track to the HARP.

5.8.49. Item 49. Stopwatch time. Time, in seconds, that elapses as the aircraft traverses the stopwatch distance. Compute using the formula in [Figure 5.18](#).

Figure 5.18. Stopwatch Time Formula.

$$\frac{\text{Ground Speed (Item 43)}}{1.94} = \frac{\text{Stopwatch Distance (Item 48)}}{(\text{Stopwatch Time})(\text{Item 49})}$$

5.8.50. Item 50. SP. A percentage of the total computed drive distance to be used in the interest of safety. Consider using a SP (such as 80%) to account for jumper proficiency, DZ size, non-uniform winds, etc. Used in Item 51 to reduce the overall size of the LAR. See [paragraph 5.7.6.4](#) for more information.

5.8.51. Item 51. Adjusted LAR radius. Distance, in meters, equal to the DDD (Item 36) multiplied by the safety % (Item 50). The adjusted LAR radius defines the desired area coordinated between aircrews and jumpmasters, within which a jumper should be released. Parachute malfunction, sudden shift in wind direction or speed, or other unforeseen events

could result in failure to reach the DZ even though a jumper is released within the adjusted LAR. See [paragraph 5.3.1.1](#) for operation planning recommendations. The adjusted LAR radius is only used for canopies with known forward drive capability.

5.8.51. (AFSOC) WARNING: If both an adjusted LAR radius, safety factor, and/or a reduced percentage of the ballistic wind velocity are used, aircrews must be aware of high winds from drop altitude to the surface. Applying both values may place the HARP (the jumper) too close to the PI at too high an altitude to overcome the parachute drift due to wind effects. (T-2)

5.8.52. Item 52. Offset. Distance, in meters, aircraft run-in through LAR is offset from LAR center point.

5.8.53. Item 53. Usable green light length. Distance, in meters, from the planned LAR entry to LAR exit on run-in course, include offset and SF, as applicable. See [Figure 5.19](#).

Figure 5.19. Usable Green Light Length Formula.

$$\text{Usable Green Light Length} = 2 \times \sqrt{(\text{Adjusted LAR Radius (Item 51)}^2 - \text{Offset (Item 52)}^2)}$$

5.8.54. Item 54. Usable green light time. Usable green light length converted to time, in seconds. Compute using the formula in [Figure 5.20](#).

Figure 5.20. Usable Green Light Time Formula.

$$\frac{\text{Ground Speed (Item 43)}}{1.94} = \frac{\text{Usable Green Light Length (Item 53)}}{(\text{Usable Green Light Time})}$$

5.8.55. Item 55. Red light time. Elapsed time, in seconds, from the timing point after which airdrops cannot be safely initiated. Red light time can be based on exiting the LAR or at expiration of usable green light time (Item 54).

5.8.55. (AFSOC) Crews will turn on the red light at any point during the airdrop sequence if they believe that the drop may occur outside safe parameters or when any aircrew member states “No Drop” or “Red Light”. (T-2)

5.9. Sample HARP Problem. The following HALO example is provided to show a completed AF Form 4015.

5.9.1. Givens.

5.9.1.1. Type of Drop: Crew-Directed HALO (with 80% LAR)

5.9.1.2. Green Light Timing: LAR

5.9.1.3. Parachute: MC-4 (FD = 19.8)

5.9.1.4. Total Rigged Weight: 300 lbs (including chute)

5.9.1.5. Free fall and parachute ballistics: HV RoF = 156.6 feet per second, TFC = 11.2 seconds, DQ = 7.5 seconds, VD = 2,900 feet, DD = 380 feet, DT = 3.4 seconds, Deployed RoF = 19.2 feet per second, ET = 2.3 seconds.

5.9.1.6. Exit location: C-130, ramp

- 5.9.1.7. Drop indicated true altitude: 20,000 feet MSL
- 5.9.1.8. Actuation indicated true altitude: 4,000 feet AGL
- 5.9.1.9. PI elevation: 250 feet
- 5.9.1.10. "D" value: +750 feet
- 5.9.1.11. Preflight altimeter setting: 30.30 inches of Mercury
- 5.9.1.12. SF: Jumpmaster desires 1,000 feet, opening delay, and 1,000 feet for approach. SF = 2,000 feet.

5.9.1.13. Atmospherics:

20,000ft: 150/60 -24 °C	Average HV ballistic wind:163/44
18,000ft: 155/55 -21 °C	Average deployed ballistic wind: 165/24
16,000ft: 150/47 -17 °C	Average HV temp: -9 °C
14,000ft: 160/50 -13 °C	Average deployed temp: 11 °C
12,000ft: 170/42 -9 °C	
10,000ft: 175/40 -5 °C	
8,000ft: 180/40 -1 °C	
6,000ft: 170/35 3 °C	
4,000ft: 170/30 7 °C	
3,000ft: 165/25 9 °C	
2,000ft: 165/25 11 °C	
1,000ft: 160/20 13 °C	
Surface: 150/13 15 °C	

- 5.9.1.14. Magnetic course: 180 degrees
- 5.9.1.15. Drop airspeed: 130 knots indicate airspeed (KIAS)

5.9.2. Solution. The in-flight HARP solution can be completed using MAJCOM-approved MPS (primary), or manually via the AF Form 4015 (secondary). Complete the AF Form 4015 in [Figure 5.21](#).

Figure 5.21. Sample AF Form 4015.

HIGH ALTITUDE RELEASE POINT COMPUTATION									
NAVIGATOR'S NAME (Print)		CALLSIGN		ORGANIZATION	DATE	SIGNATURE			
FACTORS		HALO	HAHO	3-Stage Eqpmnt	FACTORS		HALO	HAHO	3-Stage Eqpmnt
1	Drop Indicated True Altitude (Local Altimeter Set)				33	Deployed Ballistic Wind (DBW) (knots)			
2	Pressure Altitude Variation	A			34	Deployed Wind Effect (DWE)			
3	Drop Pressure Altitude (29.92 Set)				35	Parachute Forward Drive (FD)	E		
4	"D" Value	+			36	Deployed Drive Distance (DDD) (Item 32 + Item 35)			
5	Drop True Altitude (MSL)				37	Total Wind Effect (TWE)			
6	Point of Impact Elevation (MSL)	-			38	Indicated/Calibrated/Equivalent/True Airspeed			
7	Drop Absolute Altitude (AGL)				39	Drop Wind Altitude			
8	Vertical Distance (R)	-			40	Magnetic Course	+		
9	Stabilization Altitude (AGL)				41	Drift Correction			
10	Point of Impact Pressure Altitude (MSL)				42	Magnetic Heading			
11a	Actuation Indicated Alt (AGL) (Actuation altimeter reads "D" at PI)				43	Ground Speed (GS)			
11b	Actuation Indicated True Alt (MSL) (Local alt set in actuation altimeter)				44	Exit Time (ET)	+		
11c	Actuation Pressure Altitude (MSL) (29.92 set in actuation altimeter)				45	Deceleration Quotient (DQ)			
11d	Absolute Actuation Alt (AGL)	B			46	Forward Travel Time (FTT)	G		
12	HV Fall Distance (HVFD) (AGL) (Item 3 - Item 11d)		O		47	Forward Travel Distance (FTD)			
13	HV Rate of Fall (R/sec)		N/A		48	Stopwatch Distance			
14	Drop Alt Temp / Surface Temp HV Average Temp (°C)	/	N/A	/	49	Stopwatch Time			
15	HV Mid Pressure Alt (HVMPA) (Item 3 - Item 8 + Item 11c)/2		N/A		50	Safety Percentage (Safety %)	H		
16	HV Ad) Rate of Fall (HV ARoF) (R/sec)	C	N/A		51	Adjusted LAR Radius			
17	HV Time of Fall (sec)	D	N/A		52	Offset			
18	Time of Fall Constant (TFC)	+	N/A		53	Usable Green Light Length			
19	HV Total Time of Fall		N/A		Usable Green Light Length = $2 \times \sqrt{\text{Adjusted LAR Radius (Item 51)}^2 - \text{Offset (Item 52)}^2}$				
20	HV Ballistic Wind (HV BW) (kts)		N/A		54	Usable Green Light Time			
21	HV Drift Effect (HVDE)	E	N/A		$\frac{\text{Ground Speed (Item 43)} \times \text{Usable Green Light Length (Item 53)}}{1.94 \times \text{Usable Green Light Time}}$				
22	Actuation Alt (R/AGL)				A $\frac{29.92}{1.94} \times \left(\frac{\text{Temperature}}{\text{Pressure Altitude}} + \frac{\text{Drop Altitude}}{\text{(Corrected Drop Altitude)}} \right)$				
23a	Deceleration Distance (DD) (R)	-			B $\frac{\text{Temperature}}{\text{Pressure Altitude}} + \frac{\text{Drop Altitude}}{\text{(Corrected Drop Altitude)}}$				
23b	Deceleration Time (DT) (sec)				C $\frac{\text{Average Temperature}}{\text{Average Pressure Altitude}} \times \frac{\text{(Adjusted Rate of Fall)}}{\text{Rate of Fall}}$				
24	Safety Factor (SF) (R) (Assembly + Approach)	-			D $\frac{\text{Adjusted Rate of Fall}}{1.0}$				
25	Full Deployment Altitude (FDA) (R/AGL)				E $\frac{\text{Stabilization Altitude}}{\text{Total Time of Fall}} \times \frac{\text{(Time of Fall)}}{\text{(Drift Effect)}}$				
26	Deployed Drive Fall Distance (DDFD) (R/sec)				F $\frac{1.94}{\text{Total Time of Fall}} \times \frac{\text{Fed Drive}}{\text{(Drift Effect)}}$				
27	Deployed Rate of Fall	/	/	/	G $\frac{1.94}{\text{Groundspeed}} \times \frac{\text{Wind Speed}}{\text{(Distance)}}$				
28	Deployed Average Temperature				H $\left[\left(\frac{\text{Groundspeed (kts)}}{1.94} - \frac{\text{LAR Radius (m)}}{\text{(LAR Time)}} \right) \times 2 \right] \times \text{Safety \%}$				
29	Deployed Mid-Pressure Alt (DMPA)				Common Conversions: 1 yd = 0.91 m 1 NM = 2025 yds = 1853 m				
30	Deployed Adjusted Rate of Fall (DARoF) (R/sec)				Formulas: FTD = (ET + DQ) * GS DDE = DWE + DDD HVDE (m) = $\frac{0.61V(A - SF)}{HV \text{ ARoF}}$ DWE (m) = $\frac{0.61V(A - SF)}{\text{Deployed ARoF}}$ DDD (m) = $\frac{0.61FD(A - SF)}{\text{Deployed ARoF}}$				
31	Total Deployed Time (TDT) (sec)				NOTES:				
32	Deployed Drive Time (DDT) (sec)	F			Replaces AF IMT 4015 V2 and AF IMT 4017 V2, which are obsolete				

5.10. HARP Computation Using Formulas. As an alternative to filling out the AF Form 4015, aircrews have the option of approximating the HARP location with the following formulas for FTD, TWE, and DDD.

5.10.1. Formula standards. In all formulas, the following definitions apply:

5.10.1.1. Ballistic wind velocity. Each of the different ballistic winds (for high velocity and deployed vectors) are abbreviated ‘V’ and calculated in accordance with [paragraph 5.6.3](#).

5.10.1.2. SF. See [paragraph 5.8.24](#).

5.10.1.3. ARoF. The RoF must account for the average pressure altitude acting upon the object. **(T-3)**. This adjusted RoF is from stabilization to actuation (HV ARoF), actuation to the ground (deployed ARoF), or stabilization to the ground (also deployed RoF), depending on the type of drop being conducted. Use the RoF from the parachute ballistic data and Formula C from the AF Form 4015 to determine the adjusted RoF.

5.10.1.4. Conversion constants. For all of the below formulas 0.51 is used to convert from knots to meters per second. These constants can be replaced by 0.56 to convert from knots to yards per second.

5.10.1.5. Forward drive. The forward drive of the associated parachute, abbreviated FD and measured in knots.

5.10.2. FTD. FTD is computed the same way as a CARP, by adding the ET plus the DQ and converting that time into distance by using Formula G on the AF Form 4015. See [paragraph 4.2.30](#).

5.10.3. Total wind effect (TWE). TWE is comprised of a deployed wind effect component and a high-velocity drift effect (HVDE – HALO only) component. Compute TWE using the formula in [Figure 5.22](#).

Figure 5.22. Total Wind Effect Formula.

$$TWE = DWE + HVDE$$

5.10.3.1. Deployed wind effect (DWE). DWE is computed using the formula in [Figure 5.23](#).

Figure 5.23. Deployed Wind Effect Formula.

$$DWE \text{ (meters)} = \frac{0.51 \times DBW \times FDA}{DARoF}$$

Where:

DARoF = deployed adjusted RoF, in feet per second, see [paragraph 5.8.30](#). Item 30.

FDA = full deployment altitude, distance from actuation altitude to the ground, in feet, see [paragraph 5.8.25](#). Item 25.

DBW = deployed ballistic wind velocity, in knots, see [paragraph 5.8.33](#). Item 33.

Note: If there is a significant change in wind direction (i.e., a wind shear), it may be necessary to compute the wind drift as two rather than one vector. Should this occur, inform the jumpmaster of where the shear occurs.

5.10.3.2. High-velocity drift effect (HVDE). HVDE is calculated using the formula in [Figure 5.24](#).

Figure 5.24. High-Velocity Drift Effect Formula.

$$\text{HVDE (meters)} = \frac{0.51 \times \text{HVBW} \times \text{HVFD}}{\text{HV ARoF}}$$

Where:

HVFD = high velocity fall distance, distance from stabilization altitude to actuation altitude, in feet, see [paragraph 5.8.12.](#), Item 12.

HVBW = high velocity ballistic wind, average wind velocity, in knots, see [paragraph 5.8.20.](#), Item 20.

HV ARoF = high velocity adjusted RoF, in feet per second, see [paragraph 5.8.16.](#), Item 16.

5.10.4. Deployed drive distance (DDD). DDD is computed using formula below. In the interest of safety, a percentage (e.g., 90%) of the computed Deployed Drive Distance may be used. See [Figure 5.25](#).

5.10.4. (AFSOC) WARNING: If both an adjusted LAR radius, safety factor, and/or a reduced percentage of the ballistic wind velocity are used, aircrews must be aware of high winds from drop altitude to the surface. Applying both values may place the HARP (the jumper) too close to the PI at too high an altitude to overcome the parachute drift due to wind effects. (T-2)

Figure 5.25. Deployed Drive Distance Formula.

$$\text{DDD (meters)} = \frac{0.51 \times \text{FD} \times \text{DDFD}}{\text{DARoF}}$$

Where:

DARoF = deployed adjusted RoF, in feet per second, see [paragraph 5.8.30.](#), Item 30.

DDFD = deployed drive fall distance, distance from actuation altitude to the ground minus SF, in feet, see [paragraph 5.8.26.](#), Item 26.

FD = forward drive of the parachute, in knots, see [paragraph 5.8.35.](#), Item 35.

5.11. HARP Computation Using the Formula D=KAV.

5.11.1. The D=KAV formula is not authorized to calculate the deployed drift by USAF crews. (T-2). The D=KAV calculation is still acceptable to calculate the freefall drift of a HALO drop.

5.11.2. Other services may still allow the use of the D=KAV formula for deployed drift calculations. Crews shall be informed by the JM if the D=KAV is used for deployed drift calculations. (T-2).

5.12. Determining Drive Distance for the LAR.

5.12.1. For this section the following definitions apply:

A = actuation altitude in feet above ground level

D = drift effect in meters

DDD = deployed wind effect in meters

DWE = deployed wind effect in meters

FD = forward drive of parachute in knots

K = ballistic wind constant, see [paragraph 5.18](#)

V = average wind velocity in knots

5.12.2. Use $D=KAV$ formula to calculate the freefall vector of a HALO drop.

5.12.3. Calculate the deployed drive distance with the formula below. Multiplying the answer by 1852 converts the answer from nautical miles to meters. See [Figure 5.26](#).

Figure 5.26. Deployed Drive Distance in Meters Formula.

$$\text{DDD (meters)} = \left[\frac{(A - SF) \times FD}{K \times 1000} \right] \times 1852$$

5.12.4. Calculate the deployed wind effect with the formula below. Multiplying the answer by 1852 converts the answer from nautical miles to meters. See [Figure 5.27](#).

Figure 5.27. Deployed Wind Effect in Meters Formula.

$$\text{DWE (meters)} = \left[\frac{(A - SF) \times V}{K \times 1000} \right] \times 1852$$

5.13. HALO Plotting Instructions.

5.13.1. Select a properly scaled chart (higher airdrops result in larger offsets, necessitating smaller scale charts). Chart should be chosen such that the release point, route of flight (for aircraft and jumper), and PI and surrounding areas are visible and easily identifiable.

5.13.2. From the PI, plot deployed drift effect upwind of the PI, [Figure 5.28](#).

Figure 5.28. DDE Plot.

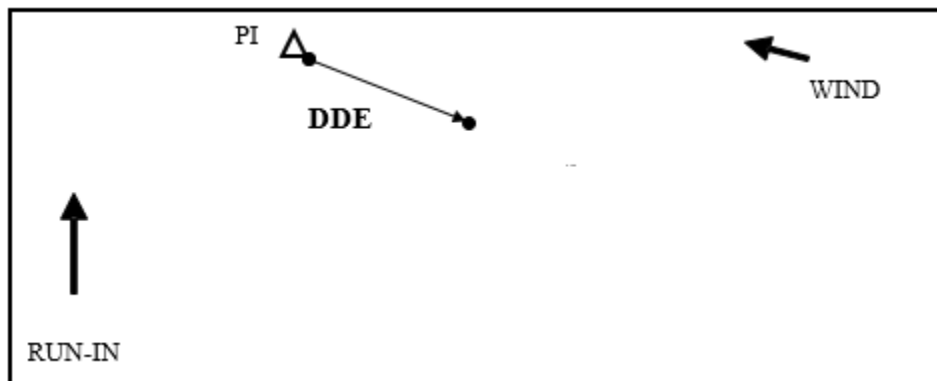

5.13.3. Next, plot the HVDE vector upwind of the DDE plot, **Figure 5.29**.

Figure 5.29. HVDE Plot.

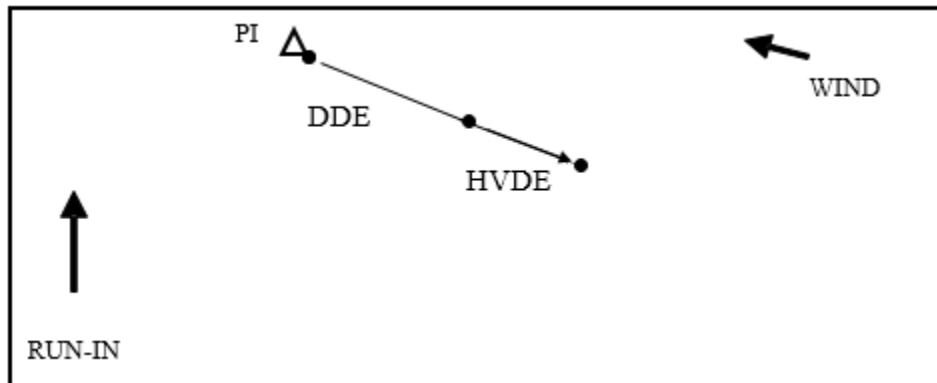

5.13.4. Next, plot the FTD from the HVDE plot in the reciprocal direction of the run-in course to account for the forward travel of the jumpers immediately following aircraft exit. This is the HALO HARP, **Figure 5.30**.

Figure 5.30. FTD Plot.

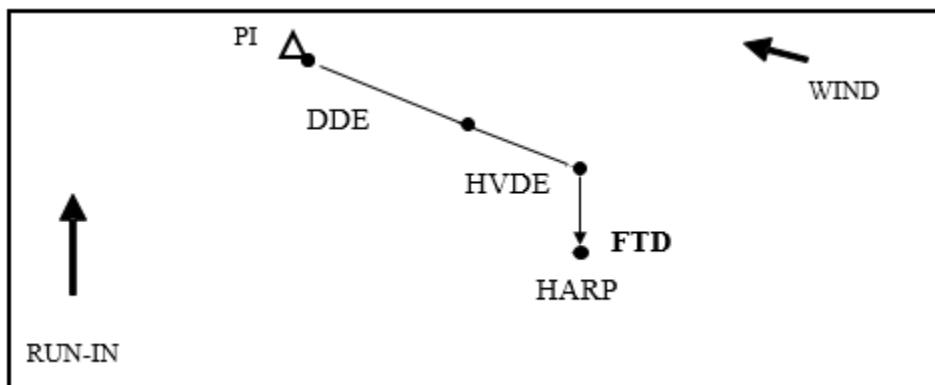

5.13.5. Identify the LAR. When required to plot the LAR, plot the DD as a radius centered on the HARP. The radius is half of the DD converted to kilometers, if necessary (Multiply by 1.85 to convert to KM). This circle represents the LAR, **Figure 5.31**.

Figure 5.31. DD Plot.

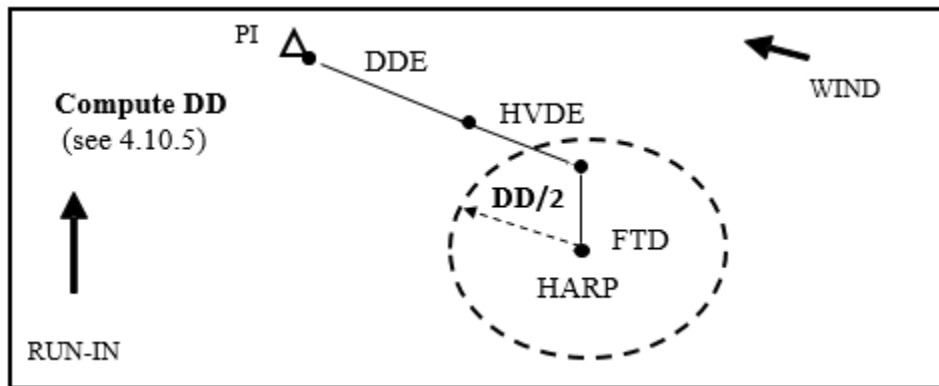

5.14. HAHO TDD Calculation. To calculate the HAHO TDD, use the formula below. Multiplying the answer by 1852 converts the answer from nautical miles to meters. See [Figure 5.32](#).

Figure 5.32. HAHO TDD Formula.

$$D \text{ (NM)} = \frac{(A-SF) \times (FD+V)}{K}$$

D = TDD, in nautical miles.

A = absolute altitude in thousands of feet

SF = safety factor altitude in thousands of feet

V = average wind velocity in knots

FD = forward drive of the parachute in knots

K = ballistic wind constant, see [paragraph 5.18](#)

5.15. HAHO Plotting Instructions. Select a properly scaled chart (higher airdrops result in larger offsets, necessitating smaller scale charts). Chart should be chosen such that the release point, route of flight (for aircraft and jumper), and PI and surrounding areas are visible and easily identifiable.

5.15.1. The HAHO HARP is computed by plotting the TDD in NM along the ballistic radial. Apply FTD to determine the HARP. See [Figure 5.33](#).

Figure 5.33. HAHO HARP.

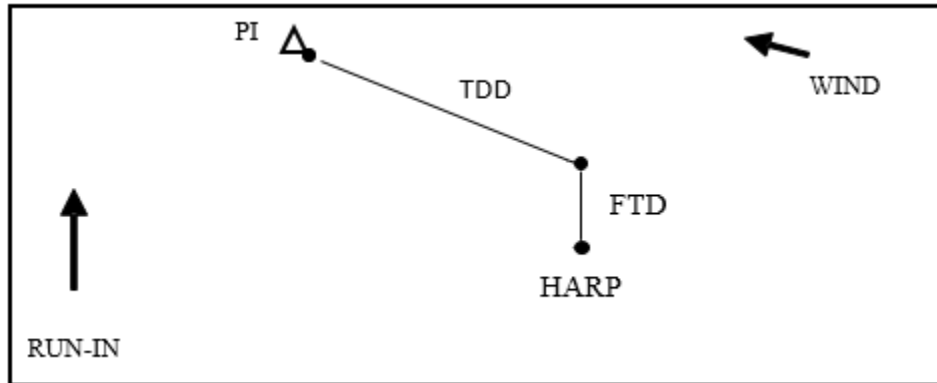

5.15.2. To plot the HAHO LAR, first plot the TDD and FTD. Then create the LAR by dividing the DD in half and plotting that distance in the reciprocal direction as the ballistic wind and parallel to the TDD. Next use the 1/2 DD as the radius to draw the LAR. See [Figure 5.34](#).

Figure 5.34. HAHO LAR.

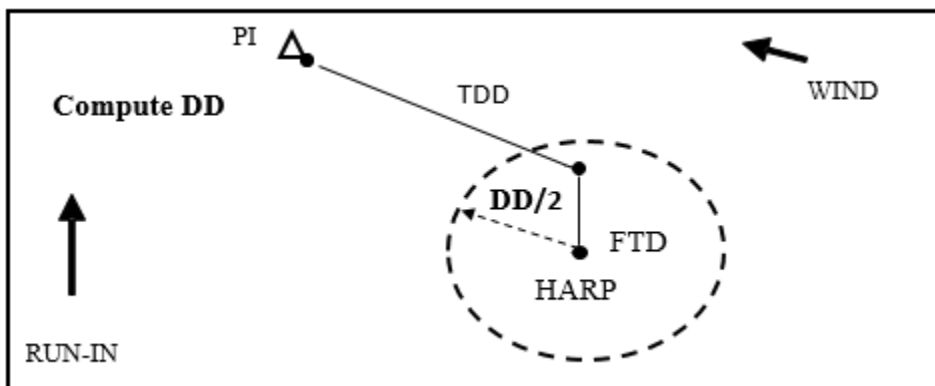

5.15.3. Jumper flight path review. After plotting the jumper route of flight, the aircrew member must examine the parachutists' descent profile in relation to surrounding terrain, threats, restricted airspace, and other limitations. **(T-2)**. If an obstacle exists, aircrew should coordinate with the jumpmaster for mitigation, an alternate tactic, or an alternate approach to the DZ.

5.15.4. Non-standard jumper route of flight. Tactics may dictate that drops cannot be made on the upwind line, due to intervening terrain, threat coverage, restricted airspace, or other limitations. In these situations, the aircrew must use the wind drift vector and drive distance to select an alternate release location that is still within the confines of the LAR in order to assure that the jumper can arrive at the PI. **(T-2)**. In the below example, the jumper could be dropped on the left edge of the LAR and still make it to the PI. If the obstacle precludes dropping from within the LAR, the drop must be fundamentally changed in terms of location, drop altitude, etc. See [Figure 5.35](#).

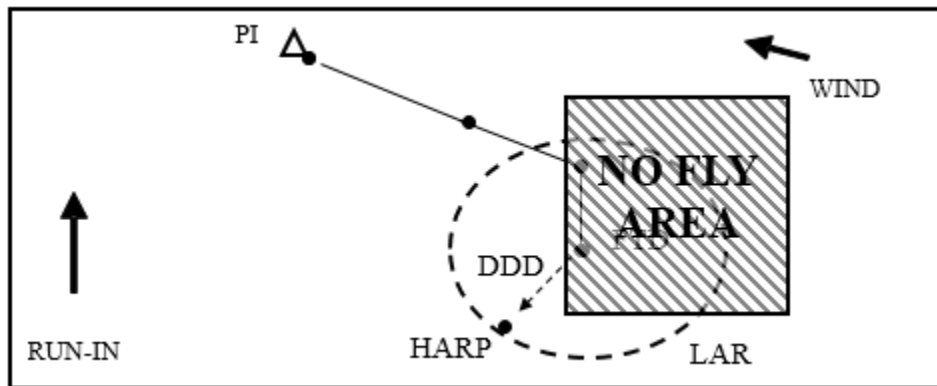
Figure 5.35. Non-Standard Jumper Route of Flight.

5.15.5. **CAUTION:** Jumping on the down-wind side of the LAR, requires additional planning for a jumper's flight path. When jumping on the down-wind side of the LAR, aircrew must coordinate with the jumpmaster to ensure they are aware jumping in this region may cause jumpers to overshoot the DZ. (T-2). Jumping at the most extreme down-wind edge of the LAR may be unrecoverable if sufficient safety altitudes and SFs have not been added.

5.16. In-Flight Updates. In flight updates of the HARP can be accomplished via MAJCOM-approved MPS, aircraft FMS, approved airborne mission network applications, or using manual computations.

5.17. Drop Documentation. (Not applicable for C-17 or C-130J when using MC calculated CARP) Complete documentation in accordance with [paragraph A2.4](#) and [paragraph A2.5](#).

5.18. K-Factor. The K-Factor for a parachute represents the nominal RoF for that parachute for a specific jumper weight (usually 300 lbs.) with embedded conversion factors to convert the final drift solution into the desired unit of distance. As K-Factor increases, the performance of the parachute decreases. The K-Factor is specific to each type of chute, and for each chute configuration, because it is calculated by using the ARoF for that particular parachute. Historically, a K-Factor of 3 is commonly used for high velocity HARP vectors, and a K-Factor of 25 is commonly used for deployed HARP vectors, although these are simply approximations of the true K-Factor. The C-130J aircraft MC uses a K-factor to generate a LAR, as does other HARP generating software. Other services use different methods for calculating K-factor, aircrew should be notified when using non-USAF methods or tables.

5.18.1. USAF K-Factor formula. This formula in [Figure 5.36](#) is the primary USAF method for K-Factor calculations. AMC ballistics in the 'HAHO' tab also use this equation. Crews shall use this equation for all K-Factor calculations. (T-2).

Figure 5.36. USAF K-Factor Formula.

$$K = \text{ARoF} \times 3.6$$

5.18.2. In the example of a freefalling jumper with an ARoF of 156.6 ft/sec, this gives a K-factor of 3.29. Similarly, a 300-lbs jumper under a deployed MC-4 canopy (RoF = 13.5 feet per second) would have a K-Factor of 48.6. For a 350-lbs jumper, the K-Factor is 52.6. It is acceptable to use published RoF data instead of ARoF if the adjusted RoF is not available.

Note: K-factors embedded in aircraft MCs are still acceptable for use. It is recommended that the MC K-factor be replaced using the above formula but this may not always be possible.

5.18.3. Other K-Factors. ATP 3-18.11, Appendix F, Table F-1 contains K-Factors for common MFF parachutes for HALO and HAHO.

Chapter 6

LEAFLET RELEASE COMPUTATIONS

6.1. General. The airdrop of leaflets in support of military information support operations (MISO) utilizes wind drift and dispersion problem measured in nautical miles rather than yards. These solutions are based on average leaflet characteristics and fundamental dead reckoning principles, complicated by the extremely long falling time from even relatively low drop altitudes. The following discussion covers the procedures for computing the best track, altitude and release point for leaflet drops. The CAT Leaflet tool is currently employed to calculate the leaflet CARP or HARP. Reference MDS specific Air Force Tactics, Techniques, and Procedures (AFTTP) 3-3 series publications for detailed employment TTP's. AFTTP's are located on the 561st Joint Tactics Squadron website.

6.2. Mission Planning. Leaflet versus CARP Theory. Leaflets move horizontally with the air mass until they reach ground level, offering little or no air resistance. Each type of leaflet has a characteristic RoF that can be used along with the ballistic wind vector to determine the release point for a given target center. Unlike parachute supported loads, however, leaflets have no forward travel vector. They do have an additional ballistic, called the spread factor that determines the size of the leaflet pattern when it hits the ground. This factor, combined with the size of the target and the wind speed, determines the drop altitude for low altitude drops. The size and shape of the target, combined with the ballistic wind direction, determines the release track of the aircraft. Leaflet operations are far more affected by in-flight conditions than CARP aerial delivery, since the actual ballistic wind affects not only the release location, but the inbound track, and for low altitude drops, the release altitude. Because of this, an accurate weather forecast is the single most important requirement for a successful leaflet mission.

6.2.1. Leaflet rate of fall. Leaflets are affected by up-drafts and down-drafts after their release, but overall they fall at a fairly constant rate of a few feet per second. The actual rate of leaflet descent varies with altitude due to the change in air density, but for low altitude drops, the rate is essentially equal to the leaflet constant sea level rate of fall. Average wind speed and RoF can be used to calculate the horizontal drift distance for the leaflets from their release point until ground contact.

6.2.2. Spread factor (RtTo). If the air was stable and all leaflets fell at exactly the same rate, they would drift with the wind in a tightly packed group to land on one spot. Instead, there is a predictable variation in the descent rates of the individual leaflets. For a given size and weight leaflet, the coefficient of variation, called RtTo or spread factor, is the ratio of the range of descent times for 90% of the leaflets to the average descent time. The larger this value, for a given drift distance, the more the leaflets spread apart. In addition, the leaflets spread a small amount, even in still air. The spread factor is independent of the total number of leaflets in the release, so that releasing a larger number of leaflets affects only the density of leaflets on the ground, and not the size of the ground pattern.

6.2.3. Target coverage planning.

6.2.3.1. Ground pattern size. The ground pattern from a single point release is elliptical in shape due to the variation in descent rates (**Figure 6.1**). Drift distance is measured along the ballistic wind direction to the center of the major axis, which is also parallel to the

ballistic wind. In addition to the spread from still air dispersion, this axis is lengthened by a factor equal to $RtTo$ times the drift distance. At low altitude, the length of the minor axis (width of the ground pattern) is due only to still air dispersion and is approximately equal to one-half the drop altitude - about 0.5 NM for a drop altitude of 6,000 feet. Because of the small size of the minor axis, a single point release is adequate only for narrow targets such as lines of communication and coastlines.

Figure 6.1. Sequence of Events in a Leaflet Release.

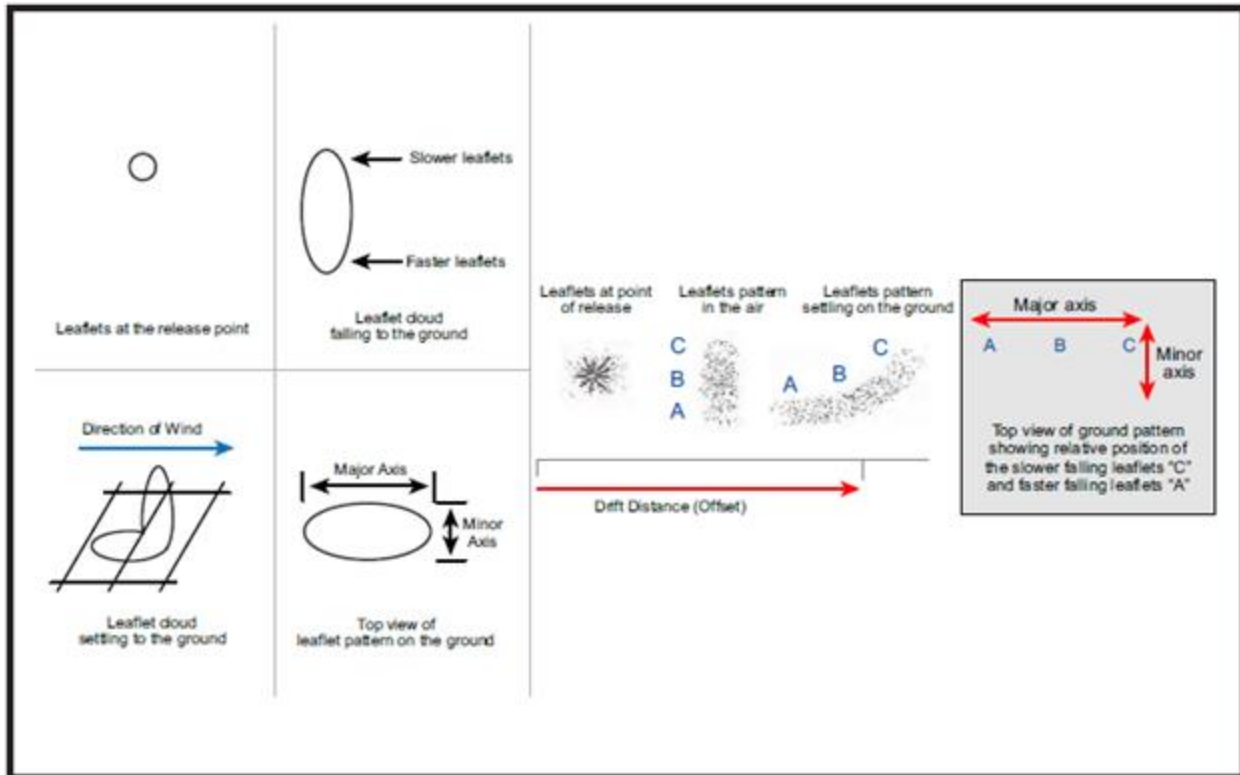

6.2.3.2. Multiple release planning. A continuous release hopper may be used if available, otherwise a series of bundles or delayed-opening packages may be dropped to cover the entire area. The area covered is always a parallelogram, with two sides parallel to the ballistic wind direction and two parallel to the aircraft track, **Figure 6.2**. The mission planner must determine the optimum parallelogram to cover the target with a minimum of spillover. **(T-3)**. To determine the ground pattern, start by drawing two lines parallel to the average wind direction at each end of the target, **Figure 6.3**, area labelled "A". These form the extreme pattern start and end points. Pick the track axis by drawing two parallel lines to enclose the target area but as little of the outside area as possible, **Figure 6.3**, area labelled "B". Finally, if excessive leaflets are to be wasted in order to include a small portion of the target area, the mission planner may elect to reduce the size of the selected parallelogram to optimize expended leaflets, **Figure 6.3**, area labelled "C". The distance along the track axis (from point A to B in **Figure 6.3**, area labelled "C") is the target length, and is used to determine the number of releases. The distance along the wind axis (from point C to D) is the major axis length, and is used to determine the drop altitude.

Figure 6.2. Multiple Bundle Release.

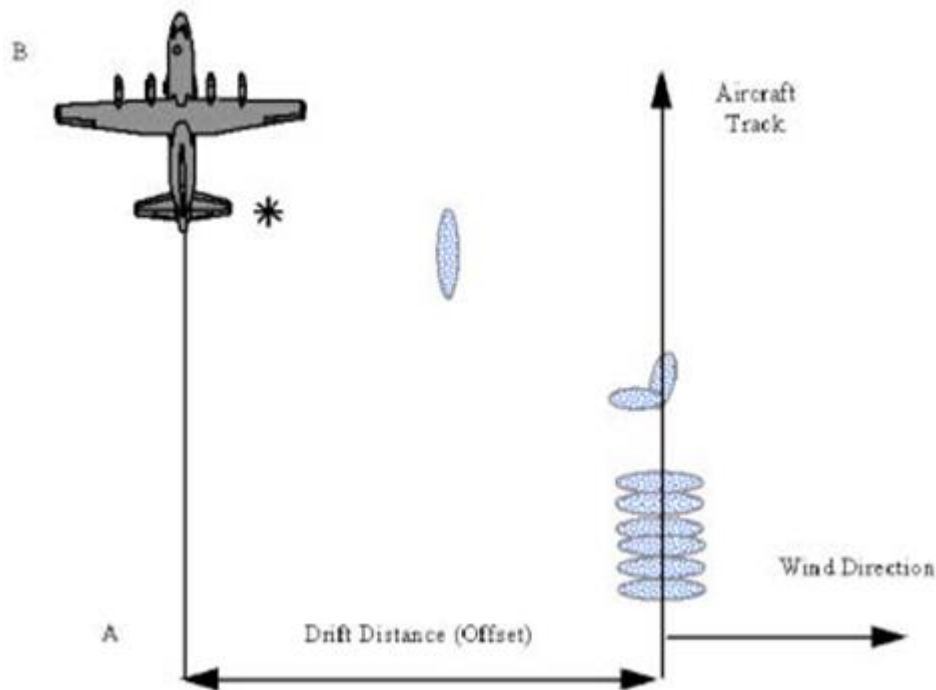
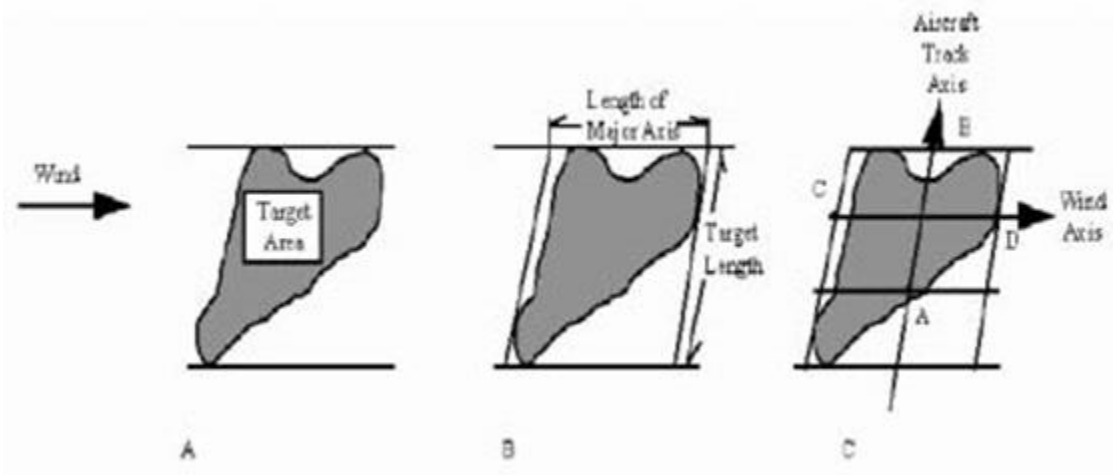

Figure 6.3. Determination of Major Axis and Target Length.



6.2.4. Low versus high altitude releases. High altitude leaflet drops permit a larger target area to be covered for a given number of leaflets. High level wind patterns, however, may place the release point inside denied airspace or expose the aircraft and crew to threats. A low altitude release may also be preferable if the target area is small, the number of leaflets is limited, or spillover into adjacent territory is to be avoided. In general, targets five miles in diameter or smaller are acceptable for low altitude drops.

6.3. Low Altitude Release Procedures (Method 1).

6.3.1. Winds. For low altitude leaflet drops, the ballistic wind affects the inbound track and the release altitude, as well as the location of the release point. Also, in a threat area, a climb to check winds over the target may not be possible. Mid-altitude winds can be checked enroute or during the climb to drop altitude. The computations shown below make it possible to update the release point using winds obtained in the climb, as long as the actual wind direction is fairly close to those used in preflight planning. Changes in wind speed, but not direction, affect the drop altitude more than the offset. These changes can be adjusted for after the climb to drop altitude has begun. Changes in the wind direction, on the other hand, are practically impossible to readjust close to the target area. This is because both the track axis and the major axis length are changed, affecting the drop altitude and the offset distance. For these reasons, an accurate preflight wind is extremely important. After obtaining preflight winds, consider the effect of any terrain in the target area and up to five to ten miles upwind of the target.

6.3.2. Wind averaging. Obtain forecast winds at the surface and at each 1,000 foot increment up to 4,000 feet above target elevation. Using the MB-4 computer wind face or graph paper, determine the net wind direction and velocity from the surface to each 1,000 foot altitude up to 4,000 feet. For additional wind vectoring techniques refer to AFPAM 11-216.

6.3.3. Instructions for completing AF Form 4011, *Low Altitude Leaflet Computations*. The net wind velocities from the averaging example above are used in the following example. While wind direction is not used directly in the calculations, the net wind direction at 4,000 feet (107 degrees) is used to determine the major axis length, [Figure 6.2](#), and [Figure 6.3](#).

6.3.3.1. Enter the preflight data for the example shown below, [Figure 6.4](#), on AF Form 4011, [Figure 6.5](#).

6.3.3.1. (AFSOC) See [Attachment 3](#) for example of AF Form 4011 completion, Low Altitude Leaflet Computation. (T-2)

Figure 6.4. Preflight Data Example.

Major axis of target (along net wind dir.): 3.0 NM

Length of target (along desired track): 4.0 NM

Leaflet type: 8.5" X 3.2" / 20# paper

6.3.3.2. If the paper weight is unknown, follow the instructions at the end of [Figure 6.6](#). With the leaflet size and paper weight, enter the reverse side of AF Form 4011, [Figure 6.6](#), to find the $RtTo$ and ground rate of fall (V_o) (0.43 and 1.7 ft/sec in the example). Enter these values in block 11, and enter the spread factor in the "1 NM drift distance" block on the graph as well. This value corresponds to 1 NM of drift distance. Mark the horizontal scale with a tick mark at the value of $RtTo$. Use dividers (or multiply $RtTo$ by 2, 3, 4, etc.) to mark tick marks at equal intervals along the rest of the horizontal scale. Label mark in intervals of 1 NM drift distance, [Figure 6.5](#).

6.3.3.3. Calculate $(RtTo)/V_o$ and enter the result in the "1 knot wind velocity" block on the graph (0.253 in the example). This value corresponds to 1 knot of wind velocity. As with the drift distance, mark the vertical scale in intervals of 1 knot. Label the marks in

intervals of 1 or 5 knots, as desired. Steps (1) and (2) above need not be repeated for each mission if the leaflet size and weight remains unchanged. The graph with marked and labeled scales may be reproduced and reused.

6.3.3.4. Mark the forecast surface wind on the vertical wind scale. Using the preflight net wind velocities calculated in **paragraph 6.3.2**, plot each net wind on each slanted altitude line, **Figure 6.5**. If necessary, obtain wind forecasts for higher altitudes and calculate additional net winds to extend the wind line as close as possible to the right side of the chart.

6.3.3.5. Mark a point (P on **Figure 6.5**) at the intersection of the wind line and the curved vertical line corresponding to the required major axis, interpolating as necessary. Project from point P vertically down to find the required offset distance upwind from the target track axis (6.4 NM in the example). Interpolate point P between the slanted altitude lines to find the required drop altitude (3000 feet in the example). Enter the Drop Altitude and Drift Distance in blocks 1 and 16 respectively.

6.3.3.6. AF Form 4011 completion requirements.

6.3.3.6.1. Item 1 - Drop altitude: The absolute altitude above the target (determined from graph).

6.3.3.6.2. Item 2 - Target elevation: Mean elevation of the target area.

6.3.3.6.3. Item 3 - True altitude: The drop altitude, in feet, above mean sea level (Item 1 plus Item 2).

6.3.3.6.4. Item 4 - PAV: The difference in feet between mean sea level and the standard datum plane. Compute using formula A and the forecast target altimeter setting, converting 0.01 inches of mercury to 10 feet of altitude.

6.3.3.6.5. Item 5 - Pressure altitude: Drop altitude, in feet, above the standard datum plane (Item 3 plus Item 4).

6.3.3.6.6. Item 6 - True altitude temperature: Temperature in degrees Celsius at the drop altitude.

6.3.3.6.7. Item 7 - Indicated altitude: The altitude to be flown with the target altimeter setting in the barometric scale or Kollsman window of the aircraft's pressure altimeter. Compute using formula B and the ALTITUDE COMPUTATIONS window of the DR computer.

6.3.3.6.8. Item 8. IAS/CAS/TAS: Indicated/Calibrated/True Airspeeds as specified by aircrew operational procedures, manuals, and directives. CAS equals IAS corrected for pitot-static error, aircraft attitude, and instrument error. EAS equals CAS corrected for compressibility. Use a drop IAS between 150 and 200 KIAS. Airspeeds above 200 KIAS are not recommended because leaflets may blow back into the cargo compartment. True airspeed is computed on the DR computer using the AIRSPEED COMPUTATIONS window and the formula:

Temperature = $\frac{(TAS)}{1.25}$

Pressure Altitude = $\frac{EAS^2}{2.98}$

- 6.3.3.6.9. Item 9 - Major axis/target length: The target major axis and length as measured from the chart.
- 6.3.3.6.10. Item 10 - Paper size/weight: Size and weight of leaflets to be dropped. If weight is unknown, follow directions on back of AF Form 4011.
- 6.3.3.6.11. Item 11 - RtTo,Vo: Spread factor and sea level RoF for the specified leaflet. Obtained from tables on back of AF Form 4011.
- 6.3.3.6.12. Item 12 - Minor axis: Width in NM of the ground pattern of each individual bundle. Always less than 1.0 NM for low altitude drops (approximately 0.08 NM per 1000 feet of drop altitude). Compute using formula C. (Not applicable to continuous (hopper) release operations.)
- 6.3.3.6.13. Item 13 - Navigator: Self-explanatory.
- 6.3.3.6.14. Item 14 - Target area: Geographic description, coordinates, or radial and DME of target area.
- 6.3.3.6.15. Item 15 - Start climb point: Distance in NM at which the aircraft should leave low level to arrive at drop altitude in time for the first release. Calculate using rate of climb at 180 KIAS (may be approximated) and the difference between drop altitude and low level enroute altitude.
- 6.3.3.6.16. Item 16 - Drift distance (Offset): Drift distance, in NM, the leaflets descend when dropped from altitude. Obtained from graph.
- 6.3.3.6.17. Item 17 - Drop altitude wind: The forecast or in-flight magnetic wind which determines the aircraft magnetic heading at release.
- 6.3.3.6.18. Item 18 - Magnetic course: The track axis selected for the target.
- 6.3.3.6.19. Item 19 - Drift correction: Computed on the DR computer using drop altitude wind, TAS and magnetic course.
- 6.3.3.6.20. Item 20 - Magnetic heading: The heading to be flown at release (Item 18 + Item 19).

Figure 6.5. Low Altitude Leaflet Computation Sample (AF Form 4011).

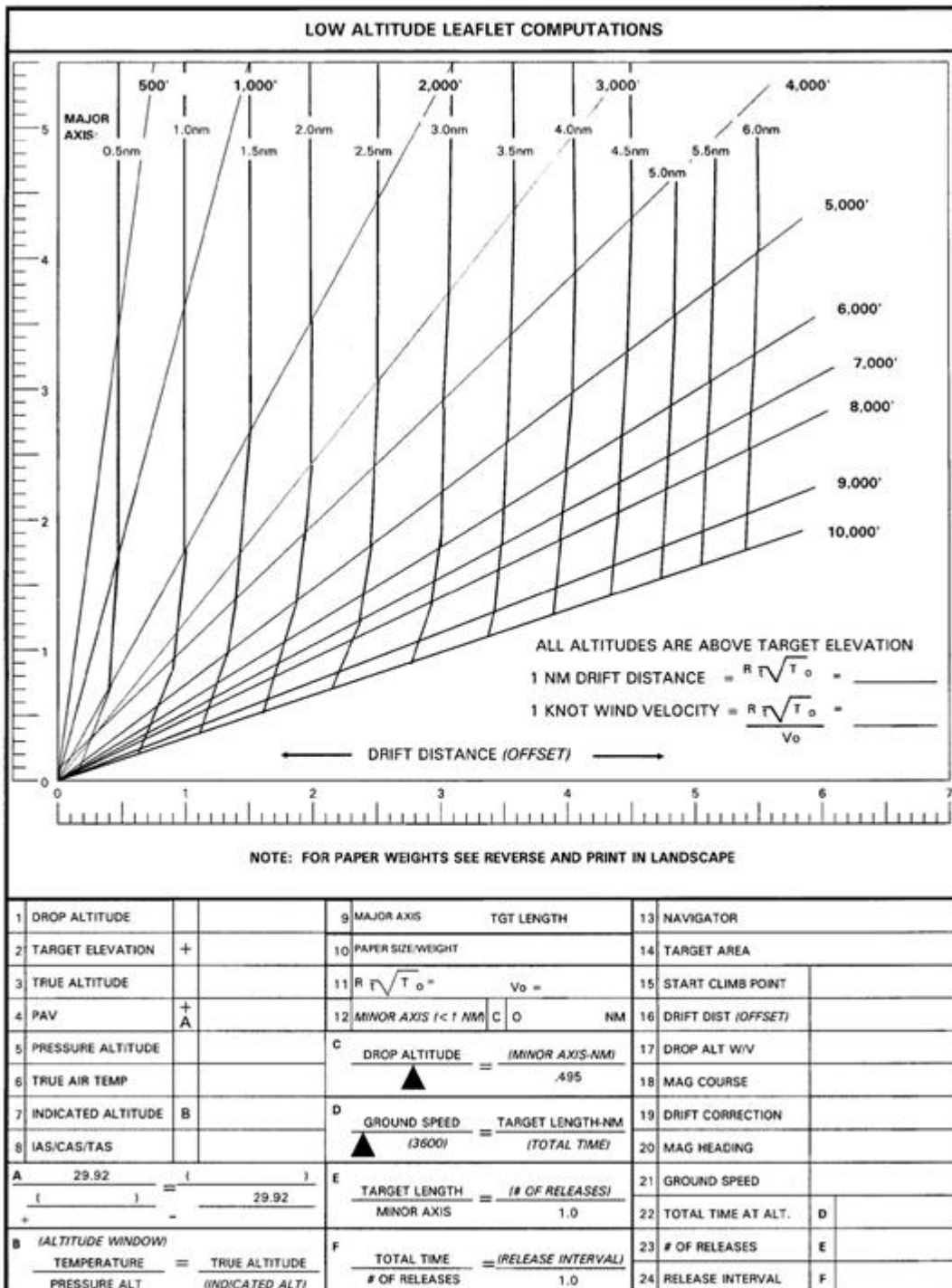

Figure 6.6. Reverse Side of AF Form 4011.**Notes:**

If paper weight is unknown, measure one pound of leaflets, multiply the area (LxW) of one leaflet by the number of leaflets in one pound, choose the paper weight listed below that most nearly equals your answer: 20,778 for 9 pound; 14,385 for 13 pound; 11,875 for 16 pound; 9,350 for 20 pound; 7,917 for 60 pound.

Asterisk values indicate leaflet is an autorotator.

6.3.3.6.21. Item 21 - Groundspeed: The preflight or actual groundspeed calculated using the drop altitude wind.

6.3.3.6.22. Item 22 - Total time at altitude: Time in seconds from the first release until the end of the release track. Compute using formula D and the seconds index (36) on the DR computer.

6.3.3.6.23. Item 23 - Number of releases: The number of bundles required for a multiple release. Compute using formula E. (Not applicable to continuous release operations.)

6.3.3.6.24. Item 24 - Release interval: Time in seconds between successive bundles for multiple drops. Compute using formula F. (Not applicable to continuous release operations.)

6.3.4. In-flight Procedures. Refer to employment volumes for specific aircraft for in-flight aircrew procedures and tactical checklists.

6.4. Low Altitude Release Procedures (Method 2).

6.4.1. **Figure 6.7.** to **Figure 6.12** contain 19 descent rates (V_0) that apply to many leaflets of various sizes and paper weights. Once the descent rate has been determined for a given leaflet, the drift distance to the center of the leaflet pattern or mass can be determined. For example, when dropping at 3000 feet the (V_0) for the 6"x3" leaflet (20 lb.) is 2.5' per second (**Figure 6.6**). For a 10 knot wind, reading across **Figure 6.7** to the 2.5 feet per second column, we find the total drift to the center of impact is 3.8 NM.

6.4.2. The length of the leaflet pattern or major axis can also be determined by multiplying the RtT_0 found on the reverse side of AF Form 4011 (**Figure 6.6**) by the total drift distance. For example, as determined above, center of mass for the 6"x3" leaflet in 20 lb. paper weight drifted 3.8NM in a 10 knot wind. To find the major axis of the leaflet pattern, multiply the spread factor (RtT_0) of 1.11 times the drift distance of 3.8 NM and the answer is 4.2 NM. To this add 1/2 of the release altitude which is 1500' or .25NM for a total major axis of 4.45 NM. The minor axis is then computed at 1/2 the release altitude. In this example the minor axis is .25 NM.

6.4.3. If a last minute decision is made to fly at a lower altitude due to high winds or low hanging clouds, an adjustment can be made to account for the change. Using the above example, if the drop is made from 2,000 feet, the drift distance is then 2/3rds of the answer shown or if from 500 feet, 1/6th of the answer shown.

6.4.4. The distance of ground elevation above sea level must also be taken into consideration. (**T-3**). The data in **Figure 6.7** to **Figure 6.12** is from the specified altitude to sea level. As in

the above example, if the target elevation is 500 feet, then the leaflet only falls 2500 feet or 5/6ths of the answer shown.

Figure 6.7. Leaflet Drift Chart - 3000 Feet.

WIND SPEED		DESCENT RATE (Vo)																	
	1.4	1.6	1.8	2.0	2.2	2.4	2.5	2.6	2.8	3.0	3.2	3.4	3.6	3.8	4.0	4.2	4.4	4.6	4.7
1	.6	.6	.5	.5	.4	.4	.4	.4	.3	.3	.3	.3	.3	.2	.2	.2	.2	.2	.2
2	1.3	1.1	1.0	.9	.8	.8	.8	.7	.7	.6	.6	.6	.5	.5	.4	.4	.4	.4	.4
3	1.9	1.7	1.5	1.4	1.3	1.2	1.1	1.1	1.0	.9	.9	.8	.8	.7	.7	.7	.6	.6	.6
4	2.6	2.2	2.0	1.8	1.7	1.6	1.5	1.5	1.3	1.2	1.1	1.1	1.1	1.0	.9	.9	.8	.8	.8
5	3.2	2.8	2.5	2.3	2.1	2.0	1.9	1.9	1.7	1.5	1.4	1.4	1.4	1.2	1.1	1.1	1.0	1.0	1.0
6	3.8	3.4	2.9	2.7	2.5	2.3	2.3	2.2	2.0	1.7	1.7	1.7	1.6	1.4	1.3	1.3	1.2	1.2	1.2
7	4.5	4.0	3.4	3.2	2.9	2.7	2.7	2.6	2.3	2.0	2.0	2.0	1.9	1.7	1.5	1.5	1.3	1.3	1.3
8	5.1	4.5	3.9	3.6	3.4	3.1	3.0	3.0	2.6	2.3	2.3	2.2	2.2	1.9	1.8	1.8	1.5	1.5	1.5
9	5.8	5.0	4.4	4.1	3.8	3.5	3.4	3.3	3.0	2.6	2.6	2.5	2.4	2.2	2.0	2.0	1.7	1.7	1.7
10	6.4	5.6	4.9	4.5	4.2	3.9	3.8	3.7	3.3	2.9	2.9	2.8	2.7	2.4	2.2	2.2	1.9	1.9	1.9
11	7.0	6.2	5.2	5.0	4.6	4.3	4.2	4.1	3.6	3.2	3.2	3.1	3.0	2.6	2.4	2.4	2.1	2.1	2.1
12	7.7	6.7	5.9	5.4	5.0	4.7	4.6	4.4	4.0	3.5	3.4	3.3	3.2	2.9	2.6	2.6	2.3	2.3	2.3
13	8.3	7.3	6.4	5.9	5.5	5.1	4.9	4.8	4.3	3.8	3.7	3.6	3.5	3.1	2.9	2.9	2.5	2.5	2.5
14	9.0	7.8	6.9	6.3	5.9	5.5	5.3	5.2	4.6	4.1	4.0	3.9	3.8	3.4	3.1	3.1	2.7	2.7	2.7
15	9.6	8.4	7.4	6.8	6.3	5.9	5.7	5.6	5.0	4.4	4.3	4.2	4.1	3.6	3.3	3.3	2.9	2.9	2.9
16	10.2	9.0	7.8	7.2	6.7	6.2	6.1	5.9	5.3	4.6	4.5	4.4	4.3	3.8	3.5	3.5	3.0	3.0	3.0

17	10.9	9.5	8.3	7.7	7.1	6.6	6.5	6.2	5.6	4.9	4.8	4.8	4.6	4.1	3.7	3.7	3.2	3.2
18	11.5	10.1	8.8	8.1	7.6	7.0	6.8	6.7	5.9	5.2	5.1	5.0	4.9	4.3	4.0	4.0	3.4	3.4
19	12.2	10.6	9.3	8.6	8.0	7.4	7.2	7.0	6.3	5.5	5.4	5.3	5.1	4.6	4.2	4.2	3.6	3.6
20	12.8	11.2	9.8	9.0	8.4	7.8	7.6	7.4	6.6	5.8	5.7	5.6	5.4	4.8	4.4	4.4	3.8	3.8
21	13.4	11.8	10.3	9.5	8.8	8.2	8.0	7.8	6.9	6.1	6.0	5.9	5.7	5.1	4.7	4.7	4.1	4.1
22	14.1	12.3	10.8	9.9	9.2	8.6	8.4	8.1	7.3	6.4	6.3	6.2	5.9	5.3	4.8	4.8	4.2	4.2
23	14.7	12.9	11.3	10.4	9.7	9.0	8.7	8.5	7.6	6.7	6.6	6.4	6.2	5.5	5.1	5.1	4.4	4.4
24	15.4	13.4	11.8	10.8	10.1	9.4	9.1	8.9	7.9	7.0	6.8	6.7	6.5	5.7	5.3	5.3	4.6	4.6
25	16.0	14.0	12.3	11.3	10.5	9.8	9.5	9.3	8.3	7.3	7.1	7.0	6.8	6.0	5.5	5.5	4.8	4.8
26	16.6	14.6	12.7	11.7	10.9	10.1	9.9	9.6	8.6	7.5	7.4	7.2	7.0	6.2	5.7	5.7	4.9	4.9
27	17.3	15.1	13.2	12.2	11.3	10.5	10.3	10.0	8.9	7.8	7.6	7.4	7.2	6.4	5.9	5.9	5.1	5.1
28	17.9	15.7	13.7	12.6	11.7	10.9	10.6	10.3	9.2	8.1	7.9	7.7	7.5	6.6	6.1	6.1	5.2	5.2
29	18.6	16.2	14.2	13.1	12.2	11.3	11.0	10.7	9.6	8.4	8.2	8.0	7.8	6.9	6.4	6.4	5.4	5.4
30	19.2	16.8	14.7	13.5	12.6	11.7	11.4	11.1	9.9	8.7	8.5	8.3	8.1	7.2	6.7	6.7	5.5	5.5

Figure 6.8. Leaflet Drift Chart - 2500 Feet.

	WIND SPEED		DESCENT RATE (Vo)																	
	1.4	1.6	1.8	2.0	2.2	2.4	2.5	2.6	2.8	3.0	3.2	3.4	3.6	3.8	4.0	4.2	4.4	4.6	4.7	
1	.5	.5	.4	.4	.3	.3	.3	.3	.3	.3	.2	.2	.2	.2	.2	.2	.2	.2	.2	.2
2	1.1	.9	.8	.8	.7	.6	.6	.6	.5	.5	.5	.4	.4	.4	.4	.4	.3	.3	.3	.2
3	1.6	1.4	1.2	1.2	1.0	.9	.9	.9	.8	.8	.7	.7	.6	.6	.5	.5	.5	.5	.5	.5

4	2.2	1.9	1.6	1.5	1.4	1.2	1.2	1.2	1.1	1.0	1.0	.9	.8	.8	.7	.7	.6	.6	.6
5	2.7	2.4	2.1	2.0	1.7	1.6	1.5	1.5	1.4	1.3	1.2	1.1	1.1	1.0	.9	.9	.8	.8	.8
6	3.2	2.8	2.5	2.3	2.0	1.9	1.8	1.7	1.6	1.5	1.4	1.3	1.3	1.1	1.1	1.1	1.0	1.0	1.0
7	3.8	3.3	2.9	2.7	2.4	2.2	2.1	2.0	1.9	1.8	1.7	1.5	1.5	1.3	1.3	1.3	1.1	1.1	1.1
8	4.3	3.8	3.3	3.1	2.7	2.5	2.4	2.3	2.2	2.0	1.9	1.8	1.7	1.5	1.4	1.4	1.3	1.3	1.3
9	4.9	4.2	3.7	3.5	3.1	2.8	2.7	2.6	2.4	2.3	2.2	2.0	1.9	1.7	1.6	1.6	1.4	1.4	1.4
10	5.4	4.7	4.1	3.9	3.4	3.1	3.0	2.9	2.7	2.5	2.4	2.2	2.1	1.9	1.8	1.8	1.6	1.6	1.6
11	5.9	5.2	4.5	4.3	3.7	3.4	3.3	3.2	3.0	2.8	2.6	2.4	2.3	2.1	2.0	2.0	1.8	1.8	1.8
12	6.5	5.6	4.9	4.7	4.1	3.7	3.6	3.5	3.2	3.0	2.9	2.6	2.5	2.3	2.2	2.2	1.9	1.9	1.9
13	7.0	6.1	5.3	5.1	4.4	4.0	3.9	3.8	3.5	3.3	3.1	2.9	2.7	2.5	2.3	2.3	2.1	2.1	2.1
14	7.6	6.6	5.7	5.5	4.8	4.3	4.2	4.1	3.8	3.5	3.4	3.1	2.9	2.7	2.5	2.5	2.2	2.2	2.2
15	8.1	7.1	6.2	5.9	5.1	4.7	4.5	4.4	4.1	3.8	3.6	3.3	3.2	2.9	2.7	2.7	2.4	2.4	2.4
16	8.6	7.5	6.6	6.2	5.4	5.0	4.8	4.6	4.3	4.0	3.8	3.5	3.4	3.0	2.9	2.9	2.6	2.6	2.6
17	9.2	8.0	7.0	6.6	5.8	5.3	5.1	4.9	4.6	4.3	4.1	3.7	3.6	3.2	3.1	3.1	2.7	2.7	2.7
18	9.7	8.5	7.4	7.0	6.1	5.6	5.4	5.2	4.9	4.5	4.4	4.0	3.8	3.4	3.3	3.3	2.9	2.9	2.9

19	10.1	8.9	7.8	7.4	6.5	5.9	5.7	5.5	5.1	4.8	4.6	4.2	4.0	3.6	3.4	3.4	3.0	3.0	3.0
20	10.8	9.4	8.2	7.8	6.8	6.2	6.0	5.8	5.4	5.0	4.8	4.4	4.2	3.8	3.6	3.6	3.2	3.2	3.2
21	11.3	9.9	8.6	8.2	7.1	6.5	6.3	6.1	5.7	5.3	5.0	4.6	4.4	4.0	3.8	3.8	3.4	3.4	3.4
22	11.9	10.3	9.0	8.6	7.5	6.8	6.6	6.4	5.9	5.5	5.3	4.8	4.6	4.2	4.0	4.0	3.5	3.5	3.5
23	12.4	10.8	9.4	9.0	7.8	7.1	6.9	6.8	6.2	5.8	5.5	5.1	4.8	4.4	4.1	4.1	3.7	3.7	3.7
24	13.0	11.3	9.8	9.4	8.2	7.4	7.2	7.0	6.5	6.0	5.8	5.3	5.0	4.6	4.3	4.3	3.8	3.8	3.8
25	13.5	11.8	10.3	9.8	8.5	7.7	7.5	7.3	6.8	6.3	6.0	5.5	5.3	4.8	4.5	4.5	4.0	4.0	4.0
26	14.0	12.2	10.7	10.1	8.8	8.1	7.8	7.5	7.0	6.5	6.2	5.7	5.5	4.9	4.7	4.7	4.2	4.2	4.2
27	14.6	12.7	11.1	10.5	9.2	8.4	8.1	7.8	7.3	6.8	6.5	5.9	5.7	5.1	4.9	4.9	4.3	4.3	4.3
28	15.1	13.2	11.5	10.9	9.5	8.7	8.4	8.1	7.6	7.0	6.7	6.2	5.9	5.3	5.0	5.0	4.5	4.5	4.5
29	15.7	13.6	11.9	11.3	9.9	9.0	8.7	8.4	7.8	7.3	7.0	6.4	6.1	5.5	5.2	5.2	4.6	4.6	4.6
30	16.2	14.1	12.3	11.7	10.2	9.3	9.0	8.7	8.1	7.5	7.2	6.6	6.3	5.7	5.4	5.4	4.8	4.8	4.8

Figure 6.9. Leaflet Drift Chart - 2000 Feet.

WIND SPEED	DESCENT RATE (Vo)
------------	-------------------

	1.4	1.6	1.8	2.0	2.2	2.4	2.5	2.6	2.8	3.0	3.2	3.4	3.6	3.8	4.0	4.2	4.4	4.6	4.7
1	.5	.4	.3	.3	.3	.3	.3	.2	.2	.2	.2	.2	.2	.2	.2	.2	.1	.1	.1
2	.9	.8	.7	.6	.6	.5	.5	.5	.5	.4	.4	.4	.4	.3	.3	.3	.3	.3	.3
3	1.4	1.2	1.0	.9	.9	.8	.8	.7	.7	.6	.6	.6	.5	.5	.5	.5	.4	.4	.4
4	1.8	1.7	1.4	1.2	1.2	1.1	1.0	1.0	.9	.8	.8	.8	.7	.6	.6	.6	.5	.5	.5
5	2.3	2.0	1.7	1.6	1.5	1.4	1.3	1.2	1.2	1.1	1.0	1.0	.9	.8	.8	.8	.7	.7	.7
6	2.7	2.3	2.0	1.9	1.8	1.6	1.5	1.4	1.4	1.3	1.2	1.1	1.1	1.0	.9	.9	.8	.8	.8
7	3.2	2.7	2.4	2.2	2.1	1.9	1.8	1.7	1.6	1.5	1.4	1.3	1.3	1.1	1.1	1.1	.9	.9	.9
8	3.6	3.1	2.7	2.6	2.5	2.2	2.0	1.9	1.8	1.7	1.6	1.5	1.4	1.3	1.2	1.2	1.0	1.0	1.0
9	4.1	3.5	3.1	2.8	2.7	2.4	2.3	2.2	2.1	1.9	1.8	1.7	1.6	1.4	1.4	1.4	1.2	1.2	1.2
10	4.5	3.9	3.4	3.1	3.0	2.7	2.5	2.4	2.3	2.1	2.0	1.9	1.8	1.6	1.5	1.5	1.3	1.3	1.3
11	5.0	4.3	3.7	3.4	3.3	3.0	2.8	2.6	2.5	2.3	2.2	2.1	2.0	1.8	1.7	1.7	1.4	1.4	1.4
12	5.4	4.7	4.1	3.7	3.6	3.2	3.0	2.9	2.8	2.5	2.4	2.3	2.2	1.9	1.8	1.8	1.6	1.6	1.6
13	5.9	5.1	4.4	4.0	3.9	3.5	3.3	3.1	3.0	2.7	2.6	2.5	2.4	2.1	2.0	2.0	1.7	1.7	1.7
14	6.3	5.5	4.8	4.3	4.2	3.8	3.5	3.3	3.2	2.9	2.8	2.7	2.6	2.2	2.1	2.1	1.8	1.8	1.8
15	6.8	5.9	5.1	4.7	4.6	4.1	3.8	3.6	3.5	3.2	3.0	2.9	2.8	2.4	2.3	2.3	2.0	2.0	2.0
16	7.2	6.2	5.4	5.0	4.8	4.3	4.0	3.8	3.7	3.4	3.2	3.1	3.0	2.6	2.5	2.5	2.1	2.1	2.1
17	7.7	6.6	5.8	5.3	5.1	4.6	4.3	4.1	3.9	3.6	3.4	3.3	3.2	2.7	2.6	2.6	2.2	2.2	2.2
18	8.1	7.0	6.1	5.6	5.4	4.9	4.5	4.3	4.1	3.8	3.6	3.5	3.4	2.9	2.7	2.7	2.3	2.3	2.3

19	8.6	7.4	6.5	5.9	5.7	5.1	4.8	4.6	4.4	4.0	3.8	3.6	3.4	3.0	2.9	2.9	2.5	2.5	2.5
20	9.0	7.8	6.8	6.2	6.0	5.4	5.0	4.8	4.6	4.4	4.0	3.8	3.6	3.2	3.0	3.0	2.6	2.6	2.6
21	9.5	8.2	7.1	6.5	6.3	5.7	5.3	5.0	4.8	4.4	4.2	4.0	3.8	3.4	3.2	3.2	2.7	2.7	2.7
22	9.9	8.6	7.5	6.8	6.6	5.9	5.5	5.3	5.1	4.6	4.4	4.2	4.0	3.5	3.3	3.3	2.9	2.9	2.9
23	10.3	9.0	7.8	7.1	6.9	6.2	5.8	5.5	5.3	4.8	4.6	4.4	4.1	3.7	3.5	3.5	3.0	3.0	3.0
24	10.8	9.4	8.2	7.4	7.2	6.5	6.0	5.8	5.5	5.0	4.8	4.6	4.3	3.8	3.6	3.6	3.1	3.1	3.1
25	11.3	9.8	8.5	7.7	7.5	6.8	6.3	6.0	5.8	5.3	5.0	4.8	4.5	4.0	3.8	3.8	3.3	3.3	3.3
26	11.7	10.1	8.8	8.1	7.8	7.0	6.5	6.2	6.0	5.5	5.2	4.9	4.7	4.2	3.9	3.9	3.4	3.4	3.4
27	12.2	10.5	9.2	8.4	8.1	7.3	6.8	6.5	6.2	5.7	5.4	5.1	4.9	4.3	4.1	4.1	3.5	3.5	3.5
28	12.6	10.9	9.5	8.7	8.4	7.6	7.0	6.7	6.4	5.9	5.6	5.3	5.0	4.5	4.2	4.2	3.6	3.6	3.6
29	13.1	11.3	9.9	9.1	8.7	7.8	7.3	7.0	6.7	6.1	5.8	5.5	5.2	4.6	4.4	4.4	3.8	3.8	3.8
30	13.5	11.7	10.2	9.3	8.9	8.0	7.5	7.2	6.9	6.3	6.0	5.7	5.4	4.8	4.5	4.5	3.9	3.9	3.9

Figure 6.10. Leaflet Drift Chart - 1500 Feet.

	WIND SPEED			DESCENT RATE (Vo)															
	1.4	1.6	1.8	2.0	2.2	2.4	2.5	2.6	2.8	3.0	3.2	3.4	3.6	3.8	4.0	4.2	4.4	4.6	4.7
1	.4	.3	.3	.3	.2	.2	.2	.2	.2	.2	.2	.1	.1	.1	.1	.1	.1	.1	.1
2	.7	.6	.5	.5	.5	.4	.4	.4	.3	.3	.3	.3	.3	.2	.2	.2	.2	.2	.2
3	1.1	.9	.8	.8	.7	.6	.6	.5	.5	.5	.5	.4	.4	.4	.3	.3	.3	.3	.3
4	1.4	1.2	1.0	1.0	1.0	.8	.8	.7	.7	.6	.6	.6	.5	.5	.4	.4	.4	.4	.4

5	1.8	1.5	1.3	1.3	1.2	1.0	.9	.9	.9	.8	.8	.7	.7	.6	.6	.6	.5	.5	.5
6	2.1	1.8	1.6	1.5	1.4	1.2	1.1	1.1	1.0	1.0	1.0	.8	.8	.7	.7	.7	.6	.6	.6
7	2.5	2.1	1.8	1.8	1.7	1.4	1.3	1.3	1.2	1.1	1.1	1.0	.9	.8	.8	.8	.7	.7	.7
8	2.8	2.4	2.1	2.0	1.9	1.6	1.5	1.4	1.4	1.3	1.3	1.1	1.0	1.0	.9	.9	.8	.8	.8
9	3.2	2.7	2.3	2.3	2.2	1.8	1.7	1.6	1.5	1.4	1.4	1.3	1.2	1.1	1.0	1.0	.9	.9	.9
10	3.5	3.0	2.6	2.5	2.4	2.0	1.9	1.8	1.7	1.6	1.6	1.4	1.3	1.2	1.1	1.1	1.0	1.0	1.0
11	3.9	3.3	2.9	2.8	2.6	2.2	2.1	2.0	1.9	1.8	1.8	1.5	1.4	1.3	1.2	1.2	1.1	1.1	1.1
12	4.2	3.6	3.1	3.0	2.9	2.4	2.3	2.2	2.0	1.9	1.9	1.7	1.6	1.4	1.3	1.3	1.2	1.2	1.2
13	4.6	3.9	3.4	3.3	3.1	2.6	2.5	2.3	2.2	2.1	2.1	1.8	1.7	1.6	1.4	1.4	1.3	1.3	1.3
14	4.9	4.2	3.6	3.5	3.4	2.8	2.7	2.5	2.4	2.2	2.2	2.0	1.8	1.7	1.5	1.5	1.4	1.4	1.4
15	5.3	4.5	3.9	3.8	3.6	3.0	2.9	2.7	2.6	2.4	2.4	2.1	2.0	1.8	1.7	1.7	1.5	1.5	1.5
16	5.6	4.8	4.2	4.1	3.8	3.2	3.0	2.9	2.7	2.6	2.6	2.2	2.1	1.9	1.8	1.8	1.6	1.6	1.6
17	6.0	5.1	4.4	4.3	4.1	3.4	3.2	3.1	2.9	2.7	2.7	2.4	2.2	2.0	1.9	1.9	1.7	1.7	1.7
18	6.3	5.4	4.7	4.6	4.4	3.6	3.4	3.2	3.1	2.9	2.9	2.5	2.3	2.2	2.0	2.0	1.8	1.8	1.8

19	6.7	5.7	4.9	4.8	4.6	3.8	3.6	3.4	3.2	3.0	3.0	2.7	2.5	2.3	2.1	2.1	1.9	1.9	1.9
20	7.0	6.0	5.2	5.0	4.8	4.0	3.8	3.6	3.4	3.2	3.2	2.8	2.6	2.4	2.2	2.2	2.0	2.0	2.0
21	7.4	6.3	5.5	5.3	5.0	4.2	4.0	3.8	3.6	3.4	3.4	2.9	2.7	2.5	2.3	2.3	2.1	2.1	2.1
22	7.7	6.6	5.7	5.5	5.3	4.4	4.2	4.0	3.7	3.5	3.5	3.1	2.9	2.6	2.4	2.4	2.2	2.2	2.2
23	8.1	6.9	6.0	5.8	5.5	4.6	4.4	4.1	3.9	3.7	3.7	3.2	3.0	2.8	2.5	2.5	2.3	2.3	2.3
24	8.4	7.2	6.2	6.0	5.8	4.8	4.6	4.3	4.1	3.8	3.8	3.4	3.1	2.9	2.6	2.6	2.4	2.4	2.4
25	8.8	7.5	6.5	6.3	6.0	5.0	4.8	4.5	4.3	4.0	4.0	3.5	3.3	3.0	2.8	2.8	2.5	2.5	2.5
26	9.1	7.8	6.7	6.5	6.2	5.2	4.9	4.7	4.4	4.2	4.2	3.6	3.4	3.1	2.9	2.9	2.6	2.6	2.6
27	9.5	8.1	7.0	6.8	6.5	5.4	5.1	4.9	4.6	4.3	4.3	3.8	3.5	3.2	3.0	3.0	2.7	2.7	2.7
28	9.8	8.4	7.3	7.1	6.8	5.6	5.3	5.0	4.8	4.5	4.5	3.9	3.6	3.3	3.1	3.1	2.8	2.8	2.8
29	10.2	8.7	7.5	7.3	7.0	5.8	5.5	5.2	4.9	4.6	4.6	4.1	3.7	3.4	3.2	3.2	2.9	2.9	2.9
30	10.5	9.0	7.8	7.6	7.3	6.0	5.7	5.4	5.1	4.8	4.8	4.2	3.8	3.5	3.3	3.3	3.0	3.0	3.0

Figure 6.11. Leaflet Drift Chart - 1000 Feet.

WIND SPEED	DESCENT RATE (Vo)
-------------------	--------------------------

	1. 4	1. 6	1. 8	2. 0	2. 2	2. 4	2. 5	2. 6	2. 8	3. 0	3. 2	3. 4	3. 6	3. 8	4. 0	4. 2	4. 4	4. 6	4. 7
1	.3	.2	.2	.2	.2	.2	.1	.1	.1	.1	.1	.1	.0 8	.0 8	.0 8	.0 7	.0 7	.0 7	.0 7
2	.5	.4	.4	.4	.3	.3	.3	.3	.2	.2	.2	.2	.2	.2	.2	.2	.1	.1	.1
3	.8	.7	.6	.5	.5	.5	.4	.4	.4	.3	.3	.3	.3	.2	.2	.2	.2	.2	.2
4	1. 0	.9	.8	.7	.6	.6	.6	.5	.5	.4	.4	.4	.4	.3	.3	.3	.3	.3	.3
5	1. 3	1. 1	1. 0	.9	.8	.8	.7	.7	.6	.6	.6	.5	.5	.4	.4	.4	.4	.4	.4
6	1. 5	1. 3	1. 1	1. 1	1. 0	.9	.8	.8	.7	.7	.7	.6	.5	.5	.5	.5	.4	.4	.4
7	1. 8	1. 5	1. 3	1. 3	1. 1	1. 1	1. 0	.9	.8	.8	.8	.7	.6	.6	.6	.6	.5	.5	.5
8	2. 0	1. 8	1. 5	1. 4	1. 3	1. 2	1. 1	1. 0	1. 0	.9	.9	.8	.7	.6	.6	.6	.6	.6	.6
9	2. 3	2. 0	1. 7	1. 6	1. 4	1. 4	1. 3	1. 2	1. 1	1. 0	1. 0	.9	.8	.7	.7	.7	.6	.6	.6
1 0	2. 5	2. 2	1. 9	1. 8	1. 6	1. 5	1. 4	1. 3	1. 2	1. 1	1. 1	1. 0	.9	.8	.8	.8	.7	.7	.7
1 1	2. 7	2. 4	2. 1	2. 0	1. 8	1. 7	1. 5	1. 4	1. 3	1. 2	1. 2	1. 1	1. 0	.9	.9	.9	.8	.8	.8
1 2	3. 0	2. 6	2. 3	2. 2	1. 9	1. 8	1. 7	1. 6	1. 4	1. 3	1. 3	1. 2	1. 1	1. 0	1. 0	1. 0	.8	.8	.8
1 3	3. 3	2. 9	2. 5	2. 3	2. 1	2. 0	1. 8	1. 7	1. 6	1. 4	1. 4	1. 3	1. 2	1. 0	1. 0	1. 0	.9	.9	.9
1 4	3. 5	3. 1	2. 7	2. 5	2. 2	2. 1	2. 0	1. 8	1. 7	1. 5	1. 5	1. 4	1. 3	1. 1	1. 1	1. 1	1. 0	1. 0	1. 0
1 5	3. 8	3. 3	2. 9	2. 7	2. 4	2. 3	2. 1	2. 0	1. 8	1. 7	1. 7	1. 5	1. 4	1. 2	1. 2	1. 2	1. 1	1. 1	1. 1

16	4.0	3.5	3.0	2.9	2.6	2.4	2.2	2.1	1.9	1.8	1.8	1.6	1.4	1.3	1.3	1.3	1.1	1.1	1.1
17	4.3	3.7	3.2	3.1	2.7	2.6	2.4	2.2	2.0	1.9	1.9	1.7	1.5	1.4	1.4	1.4	1.2	1.2	1.2
18	4.5	4.0	3.4	3.2	2.9	2.7	2.5	2.3	2.2	2.0	2.0	1.8	1.6	1.4	1.4	1.4	1.3	1.3	1.3
19	4.8	4.2	3.6	3.4	3.0	2.9	2.7	2.5	2.3	2.1	2.1	1.9	1.7	1.5	1.5	1.5	1.3	1.3	1.3
20	5.0	4.4	3.8	3.6	3.2	3.0	2.8	2.6	2.4	2.2	2.2	2.0	1.8	1.6	1.6	1.6	1.4	1.4	1.4
21	5.3	4.6	4.0	3.8	3.4	3.2	2.9	2.7	2.5	2.3	2.3	2.1	1.9	1.7	1.7	1.7	1.5	1.5	1.5
22	5.5	4.8	4.2	4.0	3.5	3.3	3.1	2.9	2.6	2.4	2.4	2.2	2.0	1.8	1.8	1.8	1.5	1.5	1.5
23	5.8	5.1	4.4	4.1	3.7	3.5	3.2	3.0	2.8	2.5	2.5	2.3	2.1	1.8	1.8	1.8	1.6	1.6	1.6
24	6.0	5.3	4.6	4.3	3.8	3.6	3.4	3.1	2.9	2.6	2.6	2.4	2.2	1.9	1.9	1.9	1.7	1.7	1.7
25	6.3	5.5	4.8	4.5	4.0	3.8	3.5	3.3	3.0	2.8	2.8	2.5	2.3	2.0	2.0	2.0	1.8	1.8	1.8
26	6.5	5.7	4.9	4.7	4.2	3.9	3.6	3.4	3.1	2.9	2.9	2.6	2.3	2.1	2.1	2.1	1.8	1.8	1.8
27	6.8	5.9	5.1	4.9	4.4	4.1	3.8	3.5	3.2	3.0	3.0	2.7	2.4	2.2	2.2	2.2	1.9	1.9	1.9
28	7.0	6.2	5.3	5.0	4.5	4.2	3.9	3.6	3.3	3.1	3.1	2.8	2.5	2.2	2.2	2.2	1.9	1.9	1.9

29	7.3	6.4	5.5	5.2	4.6	4.4	4.1	3.7	3.5	3.2	3.2	2.9	2.6	2.3	2.3	2.3	2.0	2.0	2.0
30	7.5	6.6	5.7	5.4	4.8	4.5	4.2	3.9	3.6	3.3	3.3	3.0	2.7	2.4	2.4	2.4	2.1	2.1	2.1

Figure 6.12. Leaflet Drift Chart - 500 Feet.

WIND SPEED	DESCENT RATE (Vo)																		
	1.4	1.6	1.8	2.0	2.2	2.4	2.5	2.6	2.8	3.0	3.2	3.4	3.6	3.8	4.0	4.2	4.4	4.6	4.7
1	.2	.1	.1	.1	.1	.1	.1	.1	.1	.1	.1	.1	.04	.04	.04	.04	.04	.04	.04
2	.3	.3	.2	.2	.2	.2	.2	.1	.1	.1	.1	.1	.1	.1	.1	.1	.1	.1	.1
3	.5	.4	.4	.3	.3	.3	.2	.2	.2	.2	.2	.2	.2	.1	.1	.1	.1	.1	.1
4	.6	.5	.5	.4	.4	.4	.3	.3	.3	.3	.3	.2	.2	.2	.2	.2	.2	.2	.2
5	.8	.7	.6	.6	.5	.5	.4	.4	.4	.4	.4	.3	.3	.2	.2	.2	.2	.2	.2
6	.9	.8	.7	.7	.6	.5	.5	.5	.5	.4	.4	.4	.4	.2	.2	.2	.2	.2	.2
7	1.1	.9	.8	.8	.7	.6	.6	.6	.6	.5	.5	.4	.4	.3	.3	.3	.3	.3	.3
8	1.2	1.0	1.0	.9	.8	.7	.6	.6	.6	.6	.6	.5	.5	.3	.3	.3	.3	.3	.3
9	1.4	1.2	1.1	1.0	.9	.8	.7	.7	.7	.6	.6	.5	.5	.4	.4	.4	.4	.4	.4
10	1.5	1.3	1.2	1.1	1.0	.9	.8	.8	.8	.7	.7	.6	.6	.4	.4	.4	.4	.4	.4
11	1.7	1.4	1.3	1.2	1.1	1.0	.9	.9	.9	.8	.8	.7	.7	.4	.4	.4	.4	.4	.4
12	1.8	1.6	1.4	1.3	1.2	1.1	1.0	1.0	1.0	.8	.8	.7	.7	.5	.5	.5	.5	.5	.5

13	2.0	1.7	1.6	1.4	1.3	1.2	1.0	1.0	1.0	.9	.9	.8	.8	.5	.5	.5	.5	.5	.5
14	2.1	1.8	1.7	1.5	1.4	1.3	1.1	1.1	1.1	1.0	1.0	.8	.8	.6	.6	.6	.6	.6	.6
15	2.3	1.9	1.8	1.7	1.5	1.4	1.2	1.2	1.2	1.1	1.1	.9	.9	.6	.6	.6	.6	.6	.6
16	2.4	2.1	1.9	1.8	1.6	1.4	1.3	1.3	1.3	1.1	1.1	1.0	1.0	.6	.6	.6	.6	.6	.6
17	2.6	2.2	2.0	1.9	1.7	1.5	1.4	1.4	1.4	1.2	1.2	1.0	1.0	.7	.7	.7	.7	.7	.7
18	2.7	2.3	2.2	2.0	1.8	1.6	1.4	1.4	1.4	1.3	1.3	1.1	1.1	.7	.7	.7	.7	.7	.7
19	2.9	2.5	2.3	2.1	1.9	1.7	1.5	1.5	1.5	1.3	1.3	1.1	1.1	.8	.8	.8	.8	.8	.8
20	3.0	2.6	2.4	2.2	2.0	1.8	1.6	1.6	1.6	1.4	1.4	1.2	1.2	.8	.8	.8	.8	.8	.8
21	3.2	2.7	2.5	2.3	2.1	1.9	1.7	1.7	1.7	1.5	1.5	1.3	1.3	.8	.8	.8	.8	.8	.8
22	3.3	2.9	2.6	2.4	2.2	2.0	1.8	1.8	1.8	1.5	1.5	1.3	1.3	.9	.9	.9	.9	.9	.9
23	3.5	3.0	2.8	2.5	2.3	2.1	1.8	1.8	1.8	1.6	1.6	1.4	1.4	.9	.9	.9	.9	.9	.9
24	3.6	3.1	2.9	2.6	2.4	2.2	1.9	1.9	1.9	1.7	1.7	1.4	1.4	1.0	1.0	1.0	1.0	1.0	1.0
25	3.8	3.3	3.0	2.8	2.5	2.3	2.0	2.0	2.0	1.8	1.8	1.5	1.5	1.0	1.0	1.0	1.0	1.0	1.0

26	3.9	3.4	3.1	2.9	2.6	2.3	2.1	2.1	2.1	1.8	1.8	1.6	1.6	1.0	1.0	1.0	1.0	1.0	1.0
27	4.1	3.5	3.2	3.0	2.7	2.4	2.2	2.2	2.2	1.9	1.9	1.6	1.6	1.1	1.1	1.1	1.1	1.1	1.1
28	4.2	3.6	3.4	3.1	2.8	2.5	2.2	2.2	2.2	1.9	1.9	1.7	1.7	1.1	1.1	1.1	1.1	1.1	1.1
29	4.4	3.7	3.5	3.2	2.9	2.6	2.3	2.3	2.3	2.0	2.0	1.7	1.7	1.2	1.2	1.2	1.2	1.2	1.2
30	4.5	3.9	3.6	3.3	3.0	2.7	2.4	2.4	2.4	2.1	2.1	1.8	1.8	1.2	1.2	1.2	1.2	1.2	1.2

6.5. High Altitude Release Procedures. High altitude leaflet releases present unique problems to the mission planner, since even a moderate change in wind direction or speed can cause the leaflet release track to be displaced several miles. Depending on the characteristics of the leaflet, the average descent time from 25,000 feet can be over five hours. Due to the long descent time planners should take expected lower altitude winds into account for several hours after the planned release time. Missions may be targeted for well-defined urban or border areas, or for large expanses of sparsely populated rural territory. Coverage of the required area is so dependent on the falling characteristics of the leaflet that the selection of size and paper weight should be confirmed only after study of the required flight profile, wind patterns, and required target coverage has been made. Planners must understand and account for terrain surrounding the intended target area to ensure that leaflets do not impact terrain between their release and the intended target area. **(T-3)**. This consideration is especially important in mountainous areas.

6.5.1. Instructions for completing AF Form 4016, *High Altitude Leaflet Computations* (**Figure 6.13**).

6.5.1.1. Enter the table on the back side of AF Form 4011 (**Figure 6.6**) with the leaflet size and paper weight to find V_0 and $R_t T_0$. Also note whether the leaflet is an auto rotator or non-auto rotator. Enter the results at the top of Section I of AF Form 4016.

6.5.1.2. Obtain forecast winds in 5,000 foot intervals up to the highest anticipated drop altitude. Enter in the wind speed and direction columns of the AF Form 4016, Section I.

6.5.1.3. Enter the table on the back side of AF Form 4016 (**Figure 6.14**) with the leaflet type (auto rotator or non-auto rotator) and ground rate of descent (V_0). Find the time factor in hours for each 5,000 foot altitude block and enter in Section I. If the average target elevation is above 1000 feet MSL, multiply the time factor for the 0-5,000 foot block by the factor $(5,000 - \text{Target Elev}) / 5,000$.

6.5.1.4. For each 5,000 foot block, calculate the drift distance and enter in Section I. Starting with the lowest altitude block, plot the drift vectors (drift distance and wind

direction) end to end on an appropriately scaled chart (1:1,000,000 scale or larger). Each vector is plotted into the wind direction, and the first vector originates from the center of the target area, **Figure 6.13**.

6.5.1.5. Measure the distance and azimuth from the end of each vector to the target center and enter in Section II. Calculate the length of the major axis for each 5,000 foot drop altitude increment on Section II as shown in **Figure 6.13**.

6.5.1.6. Compare the required target area with the major axis length for each 5,000 foot block to determine the required drop true altitude. The major axis is to be measured along the measured net wind direction for that drop altitude. Enter the selected drop altitude in Section III. If at maximum drop altitude the major axis is still too small, either:

6.5.1.6.1. Select a new leaflet size or weight with a larger coefficient of variation or slower RoF.

6.5.1.6.2. Reduce the required major axis by making two or more passes, **Figure 6.16**.

6.5.1.6.3. Postpone the mission until stronger winds are forecast.

6.5.1.6.4. Use a different drop platform with a higher altitude capability.

6.5.1.7. Determine the desired release track(s). The release track start and end points (A and B in **Figure 6.16**) are located at the drift distance (52.2 NM in **Figure 6.13**) upwind along the drop altitude net wind direction from points A and B.

Figure 6.13. High Altitude Leaflet Computation Sample.

HIGH ALTITUDE LEAFLET COMPUTATIONS							
SECTION I							
Paper Size: <u>6"x4"</u> Weight: <u>20#</u> Average Target Elevation: <u>2500</u>							
TABLE I: V_0 : <u>4.0</u> $R_1\sqrt{T_0}$: <u>0.46</u> Autorotator: <u>Non-Autorator</u> (circle one)							
Pressure Alt Interval (1000')	Time Factor (Table 2) (hours)	x	Wind Speed (knots)	= Drift Distance (nm)	Wind Direction (Degrees)		
0-5	0.17*	x	20	3.4	220		
5-10	0.33	x	25	8.3	260		
10-15	0.31	x	40	12.4	250		
15-20	0.28	x	50	14.0	250		
20-25	0.25	x	55	13.8	260		
25-30	*0.34 x $\frac{(5000-2500)}{(5000)}$						
30-35							
SECTION II							
Drop Altitude (feet)	Measured Drift Distance (nm)	x	$R_1\sqrt{T_0}$	+	No-Wind Length (nm)	Major = Axis (nm)	Measured Net Wind Direction
10,000	11.1	x	0.46	+	0.8	5.9	249°
15,000	23.5	x	0.46	+	1.2	12.0	249°
20,000	37.5	x	0.46	+	1.6	18.9	250°
25,000	52.2	x	0.46	+	2.1	26.1	252°
30,000		x			2.5		
35,000		x			2.9		
SECTION II							
Selected Drop Altitude: <u>25,000</u> feet							
No-Wind Length (nm) = Drop Altitude (feet) / 12,152 = <u>2.1</u> nm							
Minor Axis = (Maximum Deviation Value (nm) x $R_1\sqrt{T_0}$) + No-Wind Length (nm)							
= (<u>1.8</u> x <u>0.46</u>) + <u>2.1</u> = <u>2.9</u> nm							

Figure 6.14. Reverse Side of AF Form 4016 (Reverse).

TIME FACTOR (HOURS) FOR THE DESCENT OF LEAFLETS THROUGH 5,000-FT INCREMENTS - AUTORATORS								TIME FACTOR (HOURS) FOR THE DESCENT OF LEAFLETS THROUGH 5,000-FT INCREMENTS - NON-AUTORATORS							
GROUND DESCENT RATE (Ft/Sec)	0-5	5-10	10-15	15-20	20-25	25-30	30-35	GROUND DESCENT RATE (Ft/Sec)	0-5	5-10	10-15	15-20	20-25	25-30	30-35
1.0	1.36	1.28	1.18	1.07	0.96	0.86	0.76	1.0	1.37	1.31	1.22	1.11	0.98	0.84	0.71
1.1	1.24	1.16	1.07	0.97	0.87	0.78	0.69	2.0	0.69	0.66	0.61	0.56	0.49	0.42	0.35
1.2	1.13	1.06	0.98	0.89	0.80	0.71	0.63	2.1	0.65	0.62	0.58	0.53	0.47	0.40	0.34
1.3	1.05	0.98	0.91	0.82	0.74	0.66	0.58	2.2	0.62	0.60	0.56	0.50	0.45	0.38	0.32
1.4	0.97	0.91	0.84	0.76	0.69	0.61	0.54	2.3	0.60	0.57	0.53	0.48	0.43	0.37	0.31
1.5	0.91	0.85	0.78	0.71	0.64	0.57	0.50	2.4	0.57	0.55	0.51	0.46	0.41	0.35	0.29
1.6	0.85	0.80	0.74	0.67	0.60	0.54	0.47	2.5	0.55	0.52	0.49	0.44	0.39	0.34	0.28
1.7	0.80	0.75	0.69	0.63	0.57	0.50	0.45	2.6	0.53	0.50	0.47	0.43	0.38	0.32	0.27
1.8	0.76	0.71	0.65	0.59	0.53	0.48	0.42	2.7	0.51	0.49	0.45	0.41	0.36	0.31	0.26
1.9	0.72	0.67	0.62	0.56	0.51	0.45	0.40	2.8	0.49	0.47	0.44	0.40	0.35	0.30	0.25
2.0	0.68	0.64	0.59	0.53	0.48	0.43	0.38	2.9	0.47	0.45	0.42	0.38	0.34	0.29	0.24
2.1	0.65	0.61	0.56	0.51	0.46	0.41	0.36	3.0	0.46	0.44	0.41	0.37	0.33	0.28	0.24
2.2	0.62	0.58	0.53	0.49	0.44	0.39	0.34	3.1	0.44	0.42	0.39	0.36	0.32	0.27	0.23
2.3	0.59	0.56	0.51	0.47	0.42	0.37	0.33	3.2	0.43	0.41	0.38	0.35	0.31	0.26	0.22
2.4	0.57	0.53	0.49	0.45	0.40	0.36	0.32	3.3	0.42	0.40	0.37	0.34	0.30	0.26	0.25
2.5	0.54	0.51	0.47	0.43	0.38	0.34	0.30	3.4	0.40	0.39	0.36	0.33	0.29	0.25	0.21
2.6	0.52	0.49	0.45	0.41	0.37	0.33	0.29	3.5	0.39	0.37	0.35	0.32	0.28	0.24	0.20
2.7	0.50	0.47	0.44	0.40	0.36	0.32	0.28	3.6	0.38	0.36	0.34	0.31	0.27	0.23	0.20
2.8	0.49	0.46	0.42	0.38	0.34	0.31	0.27	3.7	0.37	0.35	0.33	0.30	0.27	0.23	0.19
2.9	0.47	0.44	0.41	0.37	0.33	0.30	0.26	3.8	0.36	0.35	0.32	0.29	0.26	0.22	0.19
3.0	0.45	0.43	0.39	0.36	0.32	0.29	0.25	3.9	0.35	0.34	0.31	0.28	0.25	0.22	0.18
3.1	0.44	0.41	0.38	0.35	0.31	0.28	0.24	4.0	0.34	0.33	0.31	0.28	0.25	0.21	0.18
3.2	0.43	0.40	0.37	0.33	0.30	0.27	0.24	4.1	0.33	0.32	0.30	0.27	0.24	0.21	0.17
3.3	0.41	0.39	0.36	0.32	0.29	0.26	0.23	4.2	0.33	0.31	0.29	0.26	0.23	0.20	0.17
3.4	0.40	0.38	0.35	0.31	0.28	0.25	0.22	4.3	0.32	0.31	0.28	0.26	0.23	0.20	0.16
3.5	0.39	0.36	0.34	0.31	0.27	0.24	0.22	4.4	0.31	0.30	0.28	0.25	0.22	0.19	0.16
								4.5	0.30	0.29	0.27	0.25	0.22	0.19	0.16
								4.6	0.30	0.29	0.27	0.24	0.21	0.18	0.15
								4.7	0.29	0.28	0.26	0.24	0.21	0.18	0.15
								4.8	0.29	0.27	0.25	0.23	0.20	0.18	0.15
								4.9	0.28	0.27	0.25	0.23	0.20	0.17	0.14
								5.0	0.27	0.26	0.24	0.22	0.20	0.17	0.14

6.5.1.8. Use Section III of AF Form 4016 to calculate the minor axis as follows:

6.5.1.8.1. Divide the selected drop altitude by 12,152 to obtain the no-wind minor axis in NM (2.1 in [Figure 6.13](#)).

6.5.1.8.2. To adjust for minor axis spread caused by changing wind direction between surface and drop altitude, measure the maximum lateral distance the wind vectors deviate from the net (drop altitude) drift vector (1.8 NM in [Figure 6.15](#)).

6.5.1.8.3. Add the spread factor (R_t/T_o) to the sum of (a) and (b) to obtain the minor axis.

6.5.1.8.4. Use the bottom section of AF Form 4011, to calculate and record the items in the Drop Information Summary for use in the mission and in-flight briefings.

Figure 6.15. Drift Vector Plot.

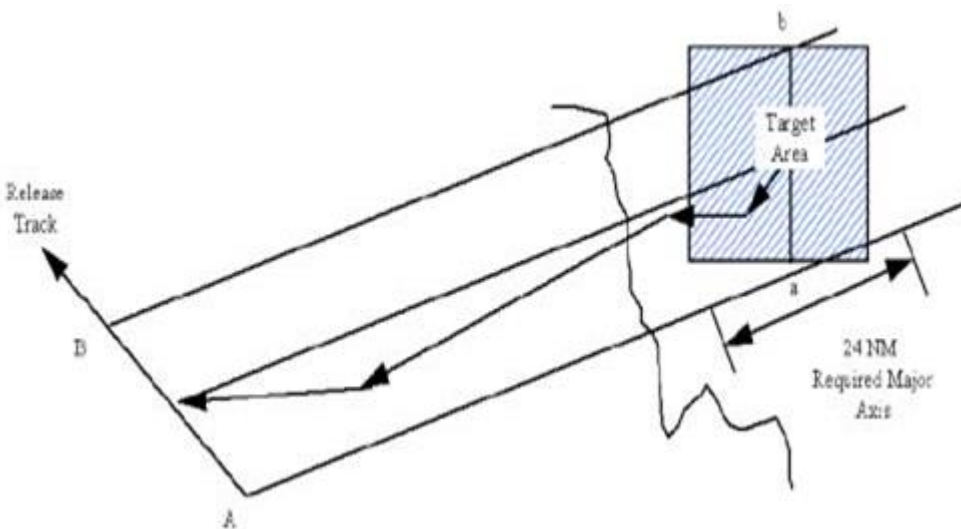
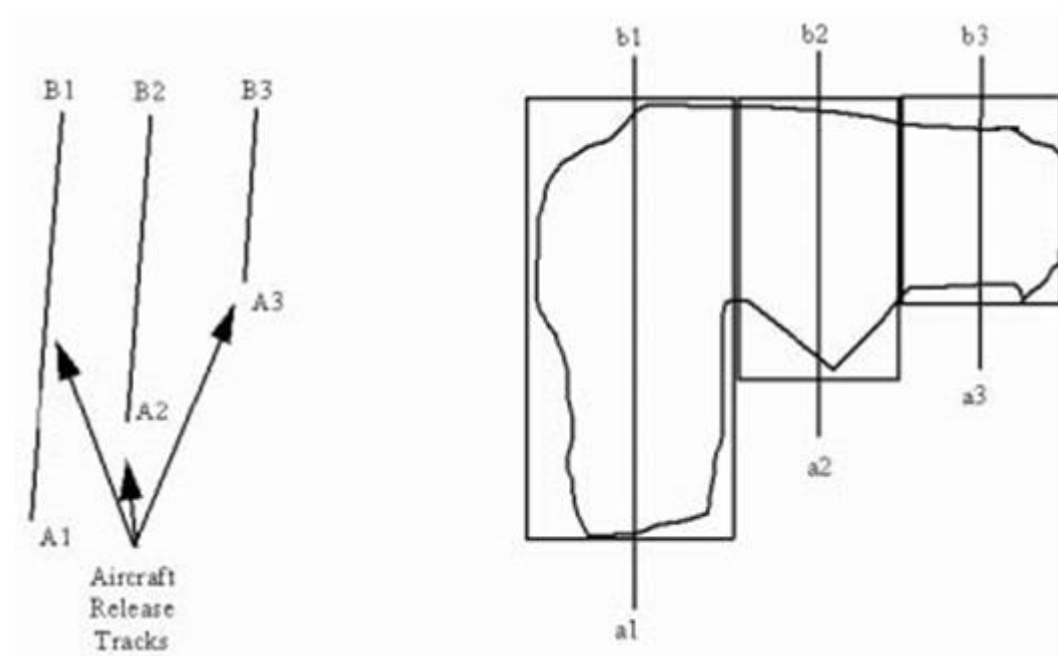

Figure 6.16. Using Multiple Passes to Expand Major Axis.



6.6. Accuracy Limitations. The accuracy of the low altitude and high altitude leaflet computation methods are only as good as the wind data upon which they so heavily depend. If complete coverage of a defined area is more critical than avoiding spillover, points A and B, in [Figure 6.16](#), can be defined farther apart to account for possible wind direction variation. The required major axis length can also be expanded by 10% to allow for variation in wind speed. In addition to wind variations, other factors can prevent the target audience from receiving the desired density of leaflets. Mountains create a "shadow" effect downwind, as leaflets land on their upwind side. High humidity during printing and processing may cause leaflets to stick together or even freeze at high altitudes, causing them to fall nearly straight down. Normally, the use of leaflets with spread factors less than 0.20 should be avoided.

6.7. (Added-AFSOC) Authorized Software. Leaf Tool is approved for computing High and Low altitude leaflet airdrops. Due to limitations in calculating leaflet airdrops when a single box of leaflets is to be dropped on individual targets, and when mission dictates, MC-130 aircrews are authorized to CARP the leaflet airdrop using mission computer parameters IAW respective MDS manuals. (T-2)

Chapter 7

SPECIAL PROCEDURES

7.1. Ground Radar Aerial Delivery System (GRADS). GRADS was developed to provide an all-weather system for aerial delivery using a ground radar to position the aircraft at an air release point. This system is currently not in use. However, this paragraph serves as a historic document for future operational use. Two radar systems are available for positioning, the SEEK POINT (TBP-1) and the SKY SPOT (MSQ-77 or equivalent). The SKY SPOT is the radar system used during radar bomb scoring (RBS)-directed airdrops.

7.1.1. GRADS terms.

7.1.1.1. Acquisition point. A preplanned point at which the ground based radar should acquire the aircraft and commence guidance.

7.1.1.2. Miss distance. The lateral distance from the planned CARP or HARP to the aircraft's actual position at release, as measured by the ground radar providing guidance.

7.1.2. GRADS procedures.

7.1.2.1. Complete the applicable CARP or HARP computations. When plotting FTD and drift effect on a graph or a DZ depiction with a meter scale, it may be desirable to convert these values, in yards, to meters by using the formula:

$$.914 = (\text{meters})$$

$$1.0 \quad (\text{yards})$$

7.1.2.2. Plot the CARP or HARP and determine its position in terms used by the radar controller, **Figure 7.1**.

7.1.2.2.1. SEEK POINT. The aircraft position will be expressed in distance north or south and distance east or west from the PI. **(T-3)**. Ensure the position is based on true cardinal directions. Since the winds and course used on the AF Form 4018 are magnetic, draw a magnetic north line on the depiction for use in plotting wind vectors and the DZ axis.

7.1.2.2.2. SKY SPOT. The aircraft position will be expressed as true bearing and distance to the PI. **(T-3)**.

7.1.2.3. The selection of the type DZ depiction is left up to the navigator and may be based on availability of map, photo, etc., coverage. Graph paper is acceptable, especially for IMC or night drops when ground features are obscured or unavailable and when aircraft altitude limits their usefulness.

7.1.3. Sample Problem:

DZ axis = 360° magnetic or 010° true

Drop wind direction = 044° magnetic

Drift effect = 300 yds. (274 meters)

FTD = 212 yds. (194 meters)

The CARP for the SEEK POINT controller would be relayed as 34 meters south, 191 meters east. The same CARP would be relayed to a SKY SPOT controller as 100° at 627 feet. Specific terminology will be in accordance with operational procedures. (T-3).

Figure 7.1. GRADS Graph Sample.

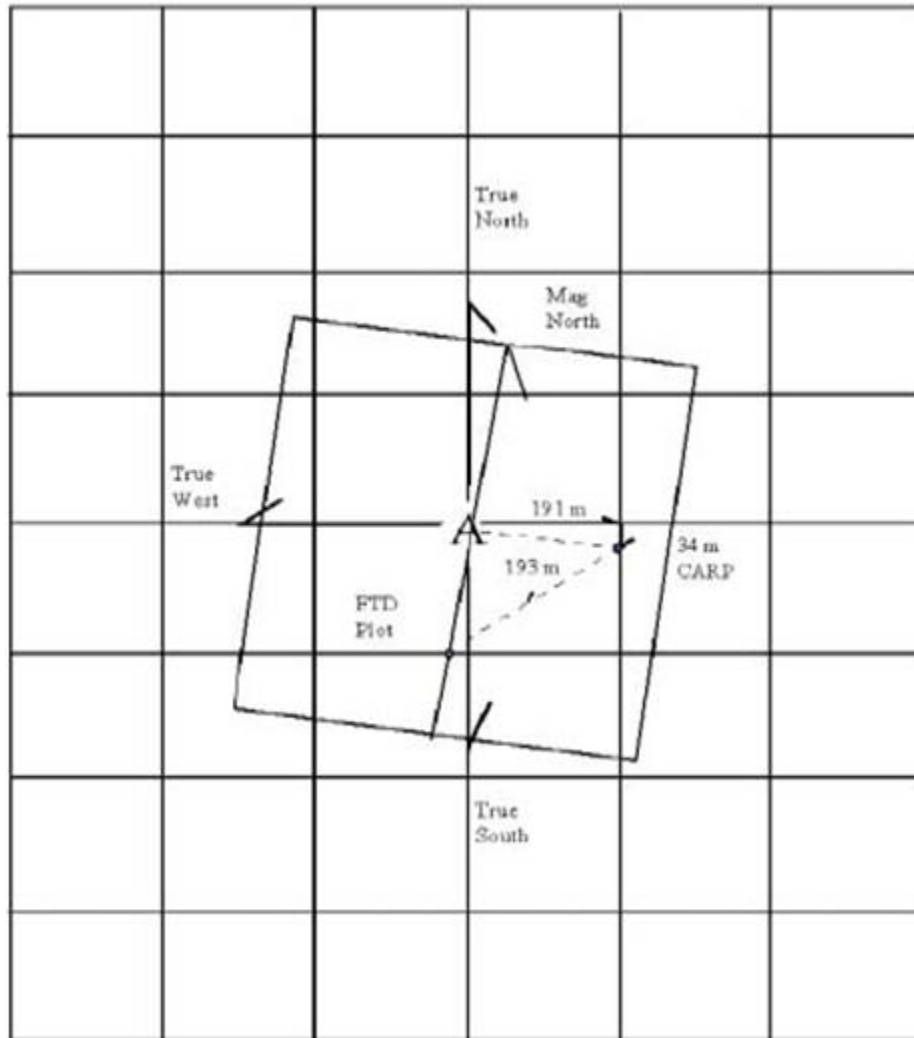

7.2. General Radar Beacon Delivery Procedures. Radar I, J and K-Band transponder beacons provide a positive means to locate, recognize and align on the DZ or landing zone. Airborne radar approaches and airdrops can be accomplished successfully by using the beacon as a terminal reference. For C-17s, see Technical Order (T.O.) 1C-17A-1-2, *Mission Computer*, for radar beacon delivery procedures.

7.2.1. Beacons are omnidirectional or directional, depending on beacon and mode selected. Normal aircrew procedures for airdrop and airland are not affected by the use of radar beacons as a terminal reference.

7.2.2. The AN/UPN-25 (X-band), AN/PPN-18 (Ku-band), AN/PPN-19 (X/Ku-band), AN/PPN-20 (X/Ku-band), SMP-1000 (X-band), and SMP-2000 (X/Ku-band) are compatible beacons. The SMP-1000 and SMP-2000 are the most common with ground teams due to their

small size and portability. See AFTTP 3-3.MC-130H, *Combat Aircraft Fundamentals – MC-130H*, for further information on radar beacon airdrops.

7.3. Massive Ordinance Air Blast (MOAB) and C-130 Weapon System Delivery Procedures, General. The MOAB system is the high altitude delivery of a 21,000 pound GPS-aided bomb from a C-130. This system depends upon the accurate positioning of the aircraft by onboard navigation equipment. The aircrew navigator is responsible for updating the targeting information and positioning the aircraft for weapons release. For additional information on GBU-43 employment, see AFTTP 3-1.MC130H, *Tactical Employment – MC-130H* and AFTTP 3-3.MC-130H.

7.4. Sight Angle Airdrop Technique. Sight angle dropping is based on a visual release using the PI marking as the visual computed air release point. A basic understanding of the sight angle dropping theory is necessary to grasp the concept of airdropping from different altitudes. These techniques are provided as a basis to work from and do not preclude units from modifying or developing alternate methods.

7.4.1. The theory behind sight angle dropping is the geometrical triangle. The three sides of the triangle are the altitude above the PI, the release point distance short of the PI and the line of sight from the aircraft to the PI, **Figure 7.2** The angle used to determine the release point is the angle formed by the sides "line of sight" and "altitude above PI", **Figure 7.2** The "altitude above PI" is calculated by adding the drop altitude to the DZ highest elevation minus the PI elevation, or by using the "altitude above PI" from Item 14 on the AF Form 4018. The "distance short of PI" is the airdrop FTD corrected for the wind vector. Once the altitude above the PI and the distance short of the PI are determined, the sight angle may be calculated.

7.4.2. Preflight.

7.4.2.1. Compute the CARP on the AF Form 4018 as normal.

7.4.2.1.1. Plot the location of the CARP relative to the PI on a blank sheet of paper (or graph paper if available) using any appropriate scale.

7.4.2.1.2. Determine the distance (in yards) the CARP falls prior to, or after, the PI. This becomes the FTD corrected for wind.

7.4.2.2. Elevation angle calculations method one (plotter method).

7.4.2.2.1. **Figure 7.3.** gives the elevation angle for a given FTD and altitude above the PI. Enter the chart with both the distance above the PI and the FTD corrected for wind. The resultant angle is the sight angle or elevation angle for the airdrop.

7.4.2.2.2. For CDS drops where the aircraft is normally flown with 7° nose up attitude, the deck angle is subtracted from the angle extracted from **Figure 7.3**.

7.4.2.2.3. Translate this angle to a visible reference in the cockpit. There are numerous ways to do this, marking the foot pedal windows with a grid to equate to yardage, using either a plotter (elevation angle) or a clinometer (complementary depression angle) to measure the angle and mark the reference point with a grease pencil or visual aid marker. The easiest method for measuring the angle in the cockpit is by using the plotter. All that is required is the plotter, string and a weight. Set up the plotter by threading the string through the center of the plotter and tie the weight to the string. The plotter is properly set up if when looking horizontally down the edge of the plotter,

the weighted string measures 90 degrees on the plotter compass and 0 degrees looking vertically at the ground.

7.4.2.3. Elevation angle calculations method two (Ratio Method).

7.4.2.3.1. At the aircraft, determine the airdrop sight angle using a simple ratio:

$$\frac{\text{Eye altitude above the ground}^*}{\text{Planned airdrop altitude}} = \frac{\text{Pace distance}}{\text{CARP dist.}}$$

*Eye altitude above the ground is the sum of the height of the aircraft floor and the navigator's height in his airdrop crouch or whatever position he plans to release from. All C-130s are 7'11" from cockpit floor to tarmac. Example: With the navigator's head next to the corner of the flight engineer's overhead panel, his eye is 5'7" from the floor. Therefore, use 13.5' as eye altitude above the ground.

Figure 7.2. Sight Angle Triangle.

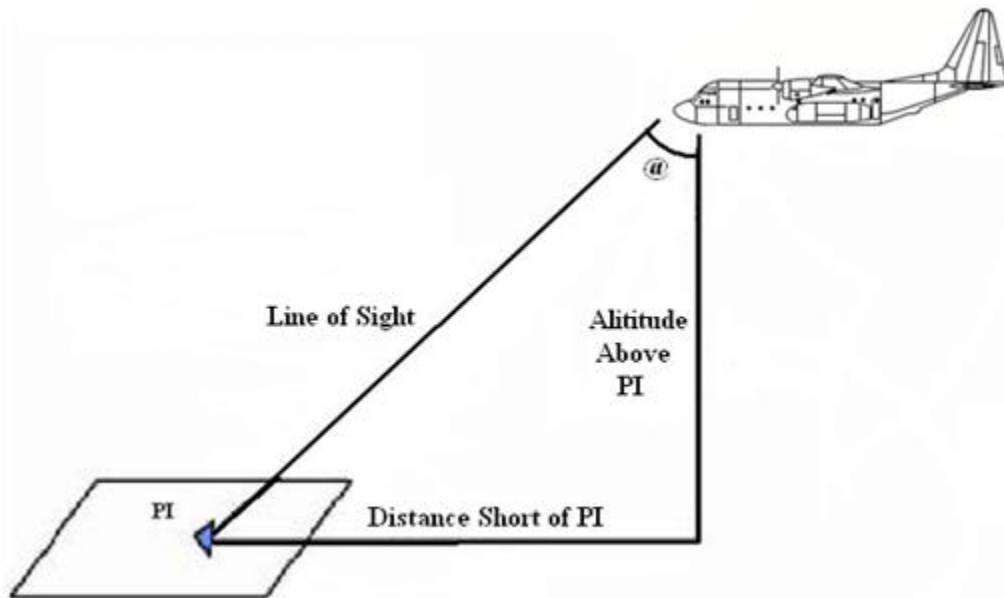
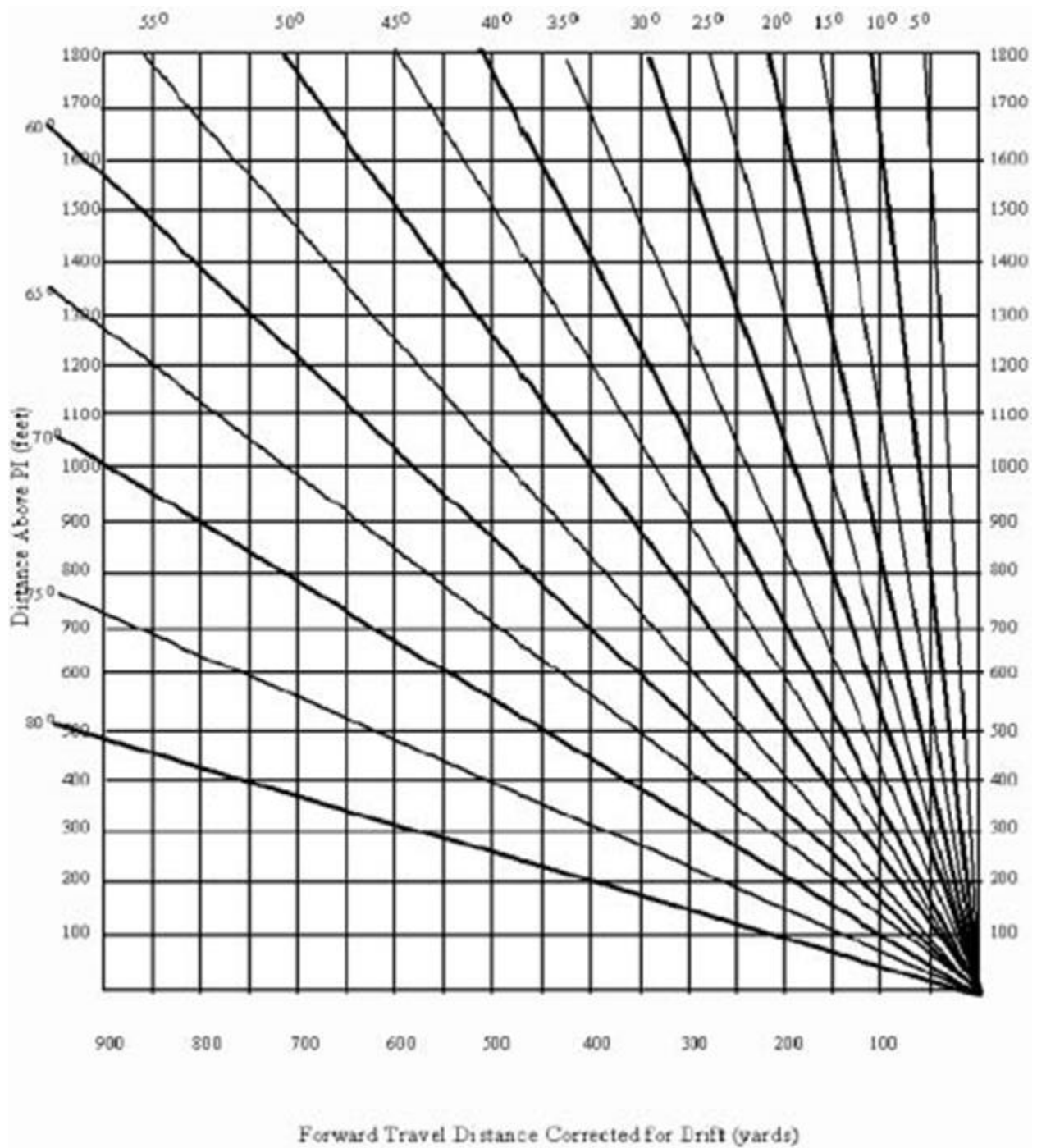

Figure 7.3. Elevation Angle Chart.



7.4.2.3.2. Compute and record the pace distance for personnel or equipment airdrops using the ratio described in [paragraph 7.4.2.3.1](#) For CDS airdrops, aircrew must apply a correction must for the increased deck angle. **(T-2)**. For CDS airdrops at 600 feet AGL, subtract 128 yards from the CARP distance plot and compute pace distance, as described.

7.4.2.3.3. Starting at the aircraft forward jack stand location, measure the pace distance, determined using the formula described above, and mark the position with a checklist, briefcase or whatever (either step it off or know the size of the ramp concrete squares). Repeat the procedure, pacing the same distance at an angle as shown in **Figure 7.4** (the angle selected is not critical, but should be sufficient to account for any expected aircraft drift on approach to the DZ). The two markers can be referred to as “scaling markers.”

7.4.2.3.4. With the two scaling markers in place, return to the aircraft cockpit. With your head in the same position from which the airdrop is to be made (e.g., against the bend in the flight engineer's overhead panel), sight through the appropriate window to the first scaling marker. Place a grease pencil mark on the window at the intersection point. Repeat this for the other scaling marker. Connect the two window grease pencil marks with a line (note that the line slopes up somewhat from the nose of the aircraft to the aft). This is the "green light" line for that particular airdrop.

7.4.2.3.5. To avoid having to scramble when in-flight conditions change the CARP location, one technique is to reaccomplish the appropriate steps for groundspeeds ten knots higher and lower than planned. Plot the 10 knot high and low "green light" adjustment lines above and below the preflight "green light" line. You may also consider repeating the above procedures for the left side of the cockpit as well.

7.4.2.4. In-flight actions. The navigator updates the CARP location and advises the pilot of the revised location. The pilot is responsible for maintaining the desired lateral displacement offset. The navigator makes minor corrections to his "green light" line and positions himself in the airdrop position on which the preflight was based. He watches the PI or timing point and calls "green light" or starts his stopwatch timing when the point passes through the line.

7.4.2.5. Error sensitivity. Accurately positioning the aircraft at the release point is the most critical phase of the airdrop mission. Sight angle airdrop methods reduce the possibility of gross airdrop errors, however, the sight angle method is only as accurate as the geometry used. Examples of error and resultant effect on aircraft positioning relative to the PI include:

7.4.2.5.1. Head positioning. If the eye is one inch from its intended position, the resultant sight angle error is (in yards):

<u>CDS</u>	<u>PERSONNEL</u>	<u>HE</u>
19.1	6.8	14.3

7.4.2.5.2. Aircraft altitude error. If the aircraft is 10 feet above or below proper altitude, the airdrop resultant sight angle error is (in yards):

<u>CDS</u>	<u>PERSONNEL</u>	<u>HE</u>
8.7	3.5	6.4

7.4.2.5.3. Aircraft deck angle error. If the aircraft deck angle is 1 degree off, the resultant sight angle error is (in yards):

<u>CDS</u>	<u>PERSONNEL</u>	<u>HE</u>
------------	------------------	-----------

28.0 (9.9) 20.9

7.4.2.5.4. Pacing error. If a 1 yard pacing error is made during preflight, the resultant sight angle error is (in yards):

CDS	PERSONNEL	HE
44.4	59.3	55.6

Figure 7.4. Placement of Scaling Markers.

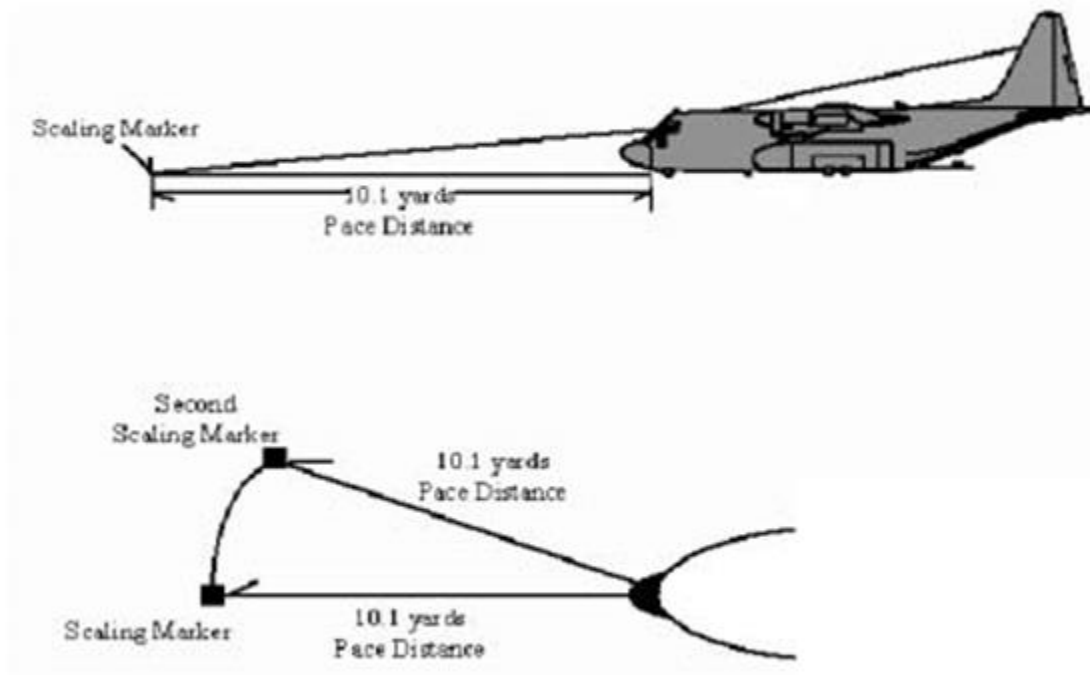

7.5. Infrared Detection Set (IDS) Airdrop (HC-130 or MC-130).

7.5.1. General. The IDS can be used to determine the release point on area DZs as the primary airdrop method or as an alternative to a planned system CARP. Improved accuracy on visual airdrops can be obtained by performing the line-up visually and accomplishing the release using the IDS.

7.5.2. Preflight procedures. Plot the CARP using AF Form 4018 in accordance with [Chapter 4](#). Convert the 5 or 10 second warning time to yards using formula H and enter the result at the bottom of the column, ([Figure 7.5](#)). Plot the location of the 5 or 10 second warning on the DZ diagram. Divide items 31 and 32 in two as shown in [Figure 7.5](#). The top half of each item is used for the 5 or 10 second warning and the bottom half for the CARP. If these items are already in use for visual timing information, use an adjacent column for the IDS data. Using all available imagery, chart information, and the criteria below, select IDS targets for line-up and release and annotate on a DZ photo, mosaic, diagram, or run-in chart (JOG or larger scale preferred).

7.5.2.1. Line-up targets. The line-up targets should be prominent so as to allow identification early enough to make final line-up corrections using the IDS alone, making allowance for the limited field of view and the difficulty of judging aircraft track relative

to the IDS monitor presentation. The line-up targets may be outside the PI or the PI itself. If available, select two or more line-up targets so that the line-up offset may be judged by comparing their relative positions. Additional targets between the initial point (IP) and the DZ should also be selected as an aid in maintaining course centerline and acquiring the DZ.

7.5.2.2. Release targets. Compute the depression angle at the 5 or 10 second warning location and the CARP by selecting an easily identifiable target as close to DZ center-line as possible. The PI itself should be used as the target if it is visually prominent. Measure the direct distances from the target to the 5 or 10 second warning location and the CARP. Enter the results in Item 31. Obtain the sight angle for the warning and the CARP from these distances and **Figure 7.3**. Subtract these values from 90 degrees and enter the resulting depression angles in Item 32 (**Figure 7.5**). The depression angles can also be directly computed using the formula:

$$\text{Depression angle (degrees)} = \tan^{-1} (\text{Drop altitude (feet)} / \text{Distance (yards)} / 3)$$

7.5.3. In-flight procedures. Depending on equipment installation, the IDS turret may not be stabilized for pitch, roll, or drift. In this case, elevation and azimuth readings could be accurate only during straight and level flight. Aircrew must apply track angle error to turret azimuth when checking DZ alignment. **(T-3)**. If the aircraft pitch angle at release can be determined before the drop, the pitch angle must be added to the computed depression angle. **(T-3)**. After the 1 minute warning, monitor the turret position indicators and call the 10 second warning and the release when the IDS turret indicators pass their respective pre-computed depression angles.

Example: If the aircraft pitch angle at drop time is to be 7 degrees nose up and the computed depression angle is 18 degrees, then the corrected depression angle is 25 degrees.

Figure 7.5. IDS Depression Angle Airdrop Example.

26	GROUND SPEED		144
27	EXIT TIME		1.9
28	DECELERATION QUOTIENT	+	0
29	FORWARD TRAVEL TIME		1.9
30	FORWARD TRAVEL DISTANCE	G	154
31	STOP WATCH DISTANCE		
32	STOP WATCH TIME	H	
33	USABLE DROP ZONE LENGTH	I	1030
34	USABLE DROP ZONE TIME	H	12.7

7.5.4. IDS Depression Angle Airdrop Example.

Drop altitude = 900 feet

Direct distance from CARP to target = 219 yards

10 seconds converted to distance = 809 yards (AF Form 4018 Formula H)

Direct distance from 10 second warning to target = 219 + 809 = 1028 yards

Depression angle at 10 second warning = 16°

Depression angle at CARP = 54°

7.6. Rescue Airdrop Procedures.

7.6.1. A capability to deliver medical personnel, survival gear, and supplies is important to keeping isolated personnel viable until a rescue can be effected. Aircrews may maintain qualification or certification to airdrop personnel and equipment using rescue airdrop procedures. These procedures can be used in lieu of standard airdrop procedures. The benefit of using these procedures is aircrews can orbit over the objective and assess the actual situation prior to committing to a type of drop. This allows better communication between the pilot and jumpmaster, enabling greater flexibility to alter type of airdrop and run-in heading. It allows aircrews to configure the aircraft for airdrop early and remain configured until all drop operations are complete.

7.6.2. The general fixed target, moving target, crosswind, and MA-1 or MA-2 kit patterns are described in applicable MDS AFTTP 3-3 series volume. However, this paragraph serves as a historic document for future operational use.

7.6.3. Airspeeds. The aircraft should be maneuvered at an appropriate speed for configuration, usually 150 KIAS or below in a racetrack pattern (aircraft may be flown on autopilot). Deployment airspeed is per [Table 7.1](#) for C-17s and [Table 8.1](#) for C-130H or C-130J. **Note:** static line deployments at airspeeds above 130 KIAS are prohibited due to parachute limitations.

7.6.4. Surface wind limits. See AFI 13-217.

7.6.5. Equipment delivery. Rescue equipment may be deployed with MA-1 or MA-2 kits, dropped as para-bundles, or dropped free-fall. Typical chute types, drop altitudes, and load weight capacities for this equipment are listed in [Table 7.1](#).

Table 7.1. Rescue Airdrop Data.

TYPE OF DELIVERY	MIN DROP ALTITUDE	WEIGHT CAPACITY
MA-1 or MA-2 kits	300 (See Note 3)	N/A
Para bundles (G-8)	300	7 - 100 lbs.
Para bundles (G-14)	400	200 - 500 lbs.
Free-Drop Equipment	150	0 - 500 lbs.
T-10C	400	100 - 350

Note 1: Deployment airspeed is 130 KIAS. (T-2).

Note 2: Flap setting is 50 percent up to 140,000 pounds aircraft gross weight, 70 percent at or above 140,000 pounds aircraft gross weight (Not applicable to C-17). (T-2).

Note 3: Drop altitude for MA-1 or MA-2 kits may be 200 AGL or above water level (AWL) if approved by MAJCOM.

7.6.6. Personnel deployment.

7.6.6.1. Static line altitudes.

7.6.6.1.1. For planning purposes, altitude for personnel deployment is normally not lower than 800 feet AGL in training, depending on the parachute type. Consult the rescue jumpmaster for training static line deployment altitudes.

7.6.6.1.2. For planning purposes, minimum operational altitude for personnel deployment is 400 feet AGL, but depends on the type of parachute. Consult the rescue jumpmaster for minimum operational deployment altitudes.

7.6.6.2. Non-static line altitudes.

7.6.6.2.1. The minimum deployment altitude is 3,000 feet AGL or AWL. Higher altitudes may be used for training.

7.6.6.2.2. For operational missions, minimum altitude with non-static line deployed a parachute is 2,500 feet AGL or AWL.

7.7. Tri-wall Aerial Delivery System (TRIADS).

7.7.1. This procedure requires MAJCOM approval prior to operation. (T-2). TRIADS is a corrugated tri-wall box rigged for static line deployment off the ramp of an aircraft. Typical loads include loose rations. Following deployment, the end-caps of the box separate from the sleeve allowing the contents to scatter and free-fall to the ground. The system can be delivered with or without a recovery parachute. MAJCOM-approved MPS (primary) or aircraft MC (secondary) will be used to compute the CARP or HARP for TRIADS airdrops. (T-2). Aircrew will use ballistics data contained in the online ballistics tables. (T-2).

7.7.2. This airdrop uses standard aircrew CDS procedures with slight modifications.

7.8. Maritime Craft Aerial Delivery System (MCADS) Rigid Hull Inflatable Boat (RHIB). MCADS provides a method to airdrop the Navy Special Warfare 11-meter RHIB. It consists of a 21-foot platform, airdrop equipment, and a specially modified RHIB. Due to the size of the RHIB, the sponsons (inflatable portion of the boat) must be deflated for the RHIB to fit into the aircraft. (T-2). Refer to AFTTP 3-3.MC-130H for the most current MCADS airdrop guidance.

Chapter 8

C-17 AERIAL DELIVERY DATA

8.1. C-17 Airdrop Airspeeds (in knots calibrated airspeed, KCAS). Aerial delivery airspeeds are a function of the force required to inflate the parachute and the airdrop altitude to minimize damage to the airdropped object. **Table 8.1** includes a list of recommended airspeeds. Crews will use the recommended airspeed in **Table 8.1** provided they are equal to or greater than the airspeeds found in applicable sections of the flight manual. **(T-3)**. In instances when the flight manual requires a higher airspeed crews will use the airspeed found in the flight manual. **(T-2)**. All crewmembers will be briefed on the drop airspeed. **(T-3)**. For combination drops, use the highest airspeed and the highest drop altitude for the loads being dropped. **(T-2)**. For specialized airdrop procedures with approved tactics bulletins or concept of operations (CONOPs), fly at the airspeed prescribed in the technical bulletin or CONOP, not to exceed flight manual tolerances. **(T-2)**. For rescue missions, when the mission requires use of airspeeds other than those recommended, ensure airspeed falls within the parachute airspeed range listed in **paragraph 7.6** or **Chapter 8** and the parameters found in applicable sections of the aircraft flight manual. **(T-2)**.

Table 8.1. C-17 Airdrop Airspeeds (KCAS).

Personnel static line	130 ± 3
Door bundle (See Note 1)	130 ± 3
Personnel HALO or HAHO	138 – 145
Dual Row Airdrop System (DRAS)	150 ± 3
Equipment or equipment and personnel combination (See Note 2)	145 ± 5
CDS or CDS and personnel combination (See Note 3 and Note 4)	145 ± 5
Extracted CDS (XCDS)	140 ± 5 or 230 ± 5
MISO material	As required for desired area coverage (Ch. 5)
<p>Note 1: For personnel static line and door bundle combinations, C-17s will use 130 ± 3 knots drop speed. (T-2).</p> <p>Note 2: Equipment and personnel combination airdrop governs combinations dropped over the ramp and will use 145 ± 5 knots drop speed. (T-2).</p> <p>Note 3: Includes free fall, HV, LV, guided CDS, LCADS, Rigging Alternative Method-Boat (RAM-B)/Advanced Rescue Craft (ARC)/Combat Expendable Platform (CEP) bundles and Ahkio Sled.</p> <p>Note 4: CDS or combination airdrop governs combinations of equipment dropped over the ramp and will use 145 ± 5 knots drop speed. (T-2).</p>	

8.2. C-17 Airdrop Altitudes. The altitudes listed in the online ballistics tables described in [paragraph 1.3.1](#) are the minimum altitudes above the highest point on the DZ. **(T-2)**. Minimum altitudes shown are intended to provide guidance and do not restrict the Army and Air Force commanders in their planning of combat operations. Altitudes are based on the technical design characteristics of the parachutes and represent the minimum at which the parachutes may be expected to perform their intended function with acceptable reliability. Use of lower altitudes than shown may result in the parachute(s) failing to achieve their design performance and introduce safety hazards to jump personnel or result in unacceptable damage to loads.

8.2.1. Acceptable tolerance for drop altitude is defined as -50' and +100'. **(T-2)**. This tolerance is not intended to alter the minimum or maximum *planned* drop altitudes listed in the online ballistics tables. It is an allowable tolerance for the aircraft to be at when drop execution is initiated.

8.2.2. For formation drops, no aircraft will drop at a lower altitude than a preceding aircraft in the formation. **(T-3)**. When load compatibility or operational considerations permit, stack elements beginning with the lowest drop altitude.

8.2.3. For combination drops, the load requiring the highest minimum drop altitude determines the aircraft drop altitude. **(T-3)**.

8.2.4. Airdrops above 3,000 feet AGL will be conducted with high altitude parachutes, either high velocity parachutes, HALO, HAHO, or JPADS. **(T-3)**.

8.3. Aerial Delivery Wind Limitations. Wind limits are in accordance with AFI 13-217 and apply only to Air Force loads. Non-Air Force load wind limitations are at the discretion of the supported unit DZ safety officer (DZSO). When surface winds are known, airdrop decisions are based solely on surface wind limitations. When surface winds are unknown (e.g., blind drops to unmanned DZs) the jumpmaster and army airborne mission commander (if designated) will be advised by the aircrew when drop altitude winds exceed 30 knots for personnel drops. **(T-3)**. For blind equipment and bundle aerial deliveries to unmanned DZs, the aircraft commander will make the decision to drop. **(T-3)**.

8.4. C-17 Aerial Delivery Ballistics General. The online ballistics tables contain the ballistic data for a variety of load and parachute types in use by all four services. The ballistics of different types of parachutes varies. Each parachute is designed for a specific purpose and has its own unique characteristics. The data represents average information derived by ATTLA from aerial delivery tests run by the ABNSOTD, NSRDEC, and/or US Army Yuma Proving Grounds. Where exact data is not depicted, interpolate between given values. In all cases, load or rigged weight = suspended weight + parachute weight.

8.4.1. Aircrews will not make airdrops using parachutes for which the online tables do not list ballistics, unless approved by the above mentioned agencies or the MAJCOM. **(T-2)**. This does not apply to formal tests.

8.4.2. The C-17 will use the MC ballistic data for parachutes in its database. **(T-2)**. Use MAJCOM-approved computed air release point software for parachutes not in the MC database. MAJCOM/A3 may also approve use of manually entered ballistic data IAW [paragraph 3.6.3](#) **(T-2)**.

Chapter 9

C-130 AERIAL DELIVERY DATA

9.1. C-130 Aerial Delivery Airspeeds. Aerial delivery airspeeds are a function of the force required to inflate the parachute and the airdrop altitude to minimize damage to the airdropped object. **Table 9.1** includes a list of recommended airspeeds. Crews will use the recommended airspeed in **Table 9.1** provided they are equal to or greater than the airspeeds found in applicable sections of the flight manual. **(T-3)**. In instances when the flight manual requires a higher airspeed crews will use the airspeed found in the appropriate chart found in the flight manual. **(T-2)**. All crewmembers will be briefed on the drop airspeed. **(T-3)**. For combination drops, use the highest airspeed and the highest drop altitude for the loads being dropped. **(T-3)**. For specialized airdrop procedures with approved tactics bulletins or CONOPs, fly at the airspeed prescribed in the technical bulletin or CONOP, not to exceed Flight Manual tolerances. **(T-3)**.

9.1.1. For AFSOC and ACC (Rescue), when the mission requires use of airspeeds other than those recommended, ensure airspeed falls within the parachute airspeed range listed in **paragraph 7.6** or **Chapter 9** and the parameters found in applicable sections of the aircraft flight manual. **(T-3)**.

9.1.2. The C-130H, MC-130P, and HC-130P use KIAS. C-130J, MC-130H, MC-130J, HC-130J and EC-130J all use KCAS.

Table 9.1. C-130 Aerial Delivery Airspeeds (KIAS).

Personnel static line	130 (125 Min – 150 Max)
Personnel HALO or HAHO	130 (110 Min - 150 Max)
Door bundle (See Note 1)	130
Equipment or equipment and personnel combination (See Note 2)	130 ± 5
Heavy equipment	140
LCLA	130
CDS or CDS and personnel combination (See Note 3 and Note 4)	130 or 140
SATB	Same as type load simulated
XCDS	140±5 235±5
HSLADS	250 max (MC-130 only)
MISO material	As required for desired area coverage (Ch. 5)
Note 1: For personnel static line and door bundle combinations, C-130's will use 130 knots drop speed. (T-2) .	

Note 2: Equipment and personnel combination airdrop governs combinations dropped over the ramp and will use the higher drop speed for the equipment being airdropped. **(T-2).**

Note 3: Includes free fall, Container Release System, HV, LV, guided CDS, LCADS, RAM-B/ARC/CEP bundles and Ahkio Sled.

Note 4: CDS and combination airdrop governs combinations of equipment dropped over the ramp and will use 130 knots drop speed. **(T-2).** When the aircraft gross weight is above 120,000 pounds use the higher KIAS. **(T-2).**

9.2. C-130 Aerial Delivery Altitudes. The altitudes listed in the online ballistics tables described in [paragraph 1.3.1](#) are the minimum altitudes above the highest point on the DZ. **(T-2).** Minimum altitudes shown are intended to provide guidance and do not restrict the Army and Air Force commanders in their planning of combat operations. Altitudes are based on the technical design characteristics of the parachutes and represent the minimum at which the parachutes may be expected to perform their intended function with acceptable reliability. Use of lower altitudes than shown may result in the parachute(s) failing to achieve their design performance and introduce safety hazards to jump personnel or result in unacceptable damage to loads.

9.2. (AFSOC) C-130 Aerial Delivery Altitudes. At the request of the user, AFSOC aircrews are authorized a maximum deployment altitude of the Rescue Air deployable Maritime Boat (RAMB) (formally known as Rigging Alternate Method Zodiac (RAMZ)) and Combat Rubber Raiding Craft (CRRC) of 5,500 feet AGL. **(T-2)**

9.2.1. Acceptable tolerance for drop altitude is defined as -50' and +100'. **(T-2).** This tolerance is not intended to alter the minimum or maximum *planned* drop altitudes listed in the online ballistics tables. It is an allowable tolerance for the aircraft when drop execution is initiated.

9.2.2. For formation drops, no aircraft will drop at a lower altitude than a preceding aircraft in the formation. **(T-3).** When load compatibility or operational considerations permit, stack elements beginning with the lowest drop altitude.

9.2.3. For combination drops, the load requiring the highest minimum drop altitude determines the aircraft drop altitude. **(T-3).**

9.2.4. Airdrops above 3,000 feet AGL will be conducted with high altitude parachutes, either high velocity parachutes, HAHO, HALO, or JPADS. **(T-3).**

9.2.5. For AFSOC and ACC (Rescue), when the mission requires use of drop altitudes other than those listed in online ballistics tables, ensure the altitude falls within the parachute altitude range listed in the online ballistics tables and the parameters found in the aircraft flight manual. **(T-2).**

9.3. Aerial Delivery Wind Limitations. Wind limits are in accordance with AFI 13-217 and apply only to Air Force loads. Non-Air Force load wind limitations are at the discretion of the supported unit DZSO. When surface winds are known, airdrop decisions are based solely on surface wind limitations. When surface winds are unknown (e.g., blind drops to unmanned DZs) the jumpmaster and supported forces airborne mission commander (if designated) will be advised by the aircrew when drop altitude winds exceed 30 knots for personnel drops. **(T-3).** For blind

equipment and bundle aerial deliveries to unmanned DZs, the aircraft commander will make the decision to drop. **(T-3)**.

9.4. C-130 Aerial Delivery Parachute Ballistics. The online ballistics tables contain the ballistic data for a variety of load and parachute types in use by all four services. The ballistics of different types of parachutes varies. Each parachute is designed for a specific purpose and has its own unique characteristics. The data represents average information derived by ATTLA from aerial delivery tests run by the ABNSOTD, NSRDEC, and/or US Army Yuma Proving Grounds. Where exact data is not depicted, interpolate between given values. In all cases, load or rigged weight = suspended weight + parachute weight.

9.4.1. Aircrews will not make airdrops using parachutes for which the online tables do not list ballistics, unless approved by the above mentioned agencies or the MAJCOM. **(T-2)**. This does not apply to formal tests.

9.4.2. The C-130J will use the MC ballistic data for parachutes in its database. **(T-2)**. Use MAJCOM-approved computed air release point software for parachutes not in the MC database. MAJCOM/A3 may also approve use of manually entered ballistic data IAW **paragraph 3.6.3. (T-2)**.

JOSEPH T. GUASTELLA Jr., Lt Gen, USAF
Deputy Chief of Staff, Operations

(AFSOC)

MATTHEW W. DAVIDSON, Maj Gen, USAF
Director of Operations

Attachment 1**GLOSSARY OF REFERENCES AND SUPPORTING INFORMATION*****References***

AFI 11-215, *USAF Flight Manuals Program*, 25 March 2019

AFI 10-3503, *Personnel Parachute Program*, 23 September 2020

AFI 13-217, *Drop Zone and Landing Zone Operations*, 10 May 2007

AFI 33-322, *Records Management and Information Governance Program*, 23 March 2020

(Added-AFSOC) AFMAN 11-231, *Computed Release Point Procedures*, 18 November 2020

(Added-AFSOC) AFMAN 11-2MC-130JV3, *MC-130J--Operations Procedures*, 3 April 2020

AFPAM 11-216, *Air Navigation*, 01 March 2001

AFTTP 3-1.MC-130H, *Tactical Employment – MC-130H*, 06 April 2018

AFTTP 3-3.MC-130H, *Combat Aircraft Fundamentals – MC-130H*, 06 April 2018

ATP 3-18.11, *Special Forces Military Free-Fall Operations*, 28 April 2020

AFMAN 11-420, *Static Line Parachuting Techniques and Training*, 2018

DAFI 33-360, *Publications and Forms Management*, 01 December 2015

(Added-AFSOC) DAFI 33-360, *Publications and Forms Management*, 1 December 2015

(Added-AFSOC) DAFMAN 13-217, *Drop Zone and Landing Zone Operations*, 22 April 2021

DAFPD 11-2, *Aircrew Operations*, 31 January 19

NAVSEAINST 13512.1M, *Premeditated Personnel Parachuting and Cargo Airdrop Equipment Authorized for Navy Use*, 16 September 2011

TM 70244A-OI/A, *U.S. Marine Corps Military Freefall Operations*, 30 September 2016

TB 43-0001-80, *Personnel Parachute Authorized for Use List*, 01 July 2011

T.O. 1C-17A-1-2, *Mission Computer*, 01 December 2016

T.O. 1C-130-1-4, *C-130 Aircraft with Self Contained Navigation System*, 17 March 2012

Prescribed Forms

AF Form 4011, *Low Altitude Leaflet Computations*

AF Form 4012, *Individual Airdrop Circular Error Record*

AF Form 4013, *Modified CARP Solution*

AF Form 4015, *High Altitude Release Point Computation*

AF Form 4016, *High Altitude Leaflet Computations*

(Added-AFSOC) None

AF Form 4018, *Computed Air Release Point Computations*

Adopted Forms

AF Form 847, *Recommendation for Change of Publication*

Abbreviations and Acronyms

ACC—Air Combat Command

ABNSOTD—Army Airborne and Special Operations Test Directorate

ADRP—aerial delivery review panel

AETC—Air Education and Training Command

AFI—Air Force Instruction

AFLCMC—Air Force Life Cycle Management Center

AFMAN—Air Force Manual

AFMC—Air Force Materiel Command

AFPAM—Air Force Pamphlet

(Added-AFSOC) AFRC—Air Force Reserve Command

AFSOC—Air Force Special Operations Command

AFTTP—Air Force Tactics, Techniques, and Procedures

AFUL—approved for use list

AFWA—Air Force Weather Agency

AGL—above ground level

AGU—autonomous guidance unit

AMC—Air Mobility Command

AMC/A3TW—Air Mobility Command, Operations, Strategic Deterrence and Nuclear Integration Directorate, Flight Operations Division, Weapons and Tactics Branch

(Added-AFSOC) ANG—Air National Guard

APS—advanced parachute systems

AOD—automatic opening device

ARC—advance rescue craft

ARoF—adjusted rate of fall

ATTLA—Air Transportability Test Loading Activity

AWL—above water level

CAT—Consolidated Airdrop Tool

CARP—computed air release point

CAS—calibrated airspeed

CCT—Combat Control Team
CDS—container delivery system
CE—circular error
CEA—circular error average
CEP—combat expendable platform
COMAFFOR—commander, Air Force forces
CONOP—concept of operation
(Added-AFSOC) CRRC—Combat Rubber Raiding Craft
CSO—Combat Systems Officer
CYPRES—Cybernetic Parachute Release System
DAFI—Department of the Air Force Instruction
DARoF—deployed adjusted rate of fall
(Added-AFSOC) DBSL—Double-Bag Static Line
DBW—deployed ballistic wind
DD—deceleration distance
DDD—deployed drive distance
DDFD—deployed drive fall distance
DDT—deployed drive time
DMPA—deployed mid-pressure altitude
DQ—deceleration quotient
DRAS—Dual Row Airdrop System
DRU—direct reporting unit
DT—deceleration time
DWE—deployed wind effect
DZ—drop zone
DZC—drop zone controller
DZSO—drop zone safety officer
EAAD—Electronic Automatic Activation Device
EAS—equivalent airspeed
ET—exit time
FCIF—flight crew information file
FD—forward drive

FDA—full deployment altitude
FOA—field operating agency
Ft—feet
FTD—forward travel distance
FTT—forward travel time
GA—Guardian Angel
GPS—Global Positioning System
GRADS—Ground Radar Aerial Delivery System
GS—groundspeed
HAHO—High Altitude High Opening
HALO—High Altitude Low Opening
HARP—High Altitude Release Point
HE—heavy equipment
HSLADS—High Speed Low Level Aerial Delivery System
HV—high velocity
HVBW—high velocity ballistic wind
HVDE—high velocity drift effect
HVFD—high velocity fall distance
HVMFA—high velocity mid-pressure altitude
HV ARoF—high velocity adjusted rate of fall
IAS—indicated airspeed
ICDS—Improved Container Delivery System
IDS—Infrared Detection Set
IFR—instrument flight rules
IMC—instrument meteorological conditions
INS—inertial navigation system
IP—initial point
JPADS—Joint Precision Airdrop System
JSOC—Joint Special Operations Command
KCAS—knots calibrated airspeed
KIAS—knots indicated airspeed
KTS—knots

LAR—launch acceptability region
LCADS—Low Cost Aerial Delivery System
LCLA—Low Cost Low Altitude
LiDAR—light detection and ranging
LV—low velocity
MADS RHIB—Marine Aerial Delivery System Rigid Hulled Inflatable Boat
MAJCOM—Major Command
MC—mission computer
MCADS—Maritime Craft Aerial Delivery System
MDS—mission design series
MEW—mean effective wind
MFF—military free-fall
MOAB—Massive Ordnance Air Blast
MP—mission planner
MPS—mission planning software
MSL—mean sea level
NAVAID—navigational aid
NAVSEAINST—Naval Sea Systems Command Instruction
NM—nautical mile
NOTAM—notice to airmen
NSRDEC—Army Natick Soldier Research Development and Engineering Center
NTRAPS—non-tactical ram-air parachute systems
NVG—night vision goggles
OPR—office of primary responsibility
PADS—precision airdrop system
PAV—pressure altitude variation
PI—point of impact
PIC—pilot in command
PO—PADS operator
(Added-AFSOC) RAMB—Rescue Air deployable Maritime Boat
RAM-B—rigging alternative method-boat
(Added-AFSOC) RAMZ—Rigging Alternate Method Zodiac

RAPS—ram air parachute system
RBS—radar bomb scoring
(Added-AFSOC) RDS—Records Disposition Schedule
RHIB—rigid hull inflatable boat
RoF—rate of fall
RtTo—leaflet spread factor
SATB—standard airdrop training bundle
SCNS—self-contained navigation system
SF—safety factor
SIPRNet—Secret Internet Protocol Router Network
SKE—station keeping equipment
SOF—special operations forces
SP—safety percentage
STT—Special Tactics Team
TAS—true airspeed
TB—technical bulletin
TC—training circular
TDT—total deployed time
TFC—time of fall constant
TOT—time over target
TM—technical manual
TWE—total wind effect
TRIADS—Tri-wall Aerial Delivery System
UAT—unilateral airdrop training
USAF—United States Air Force
USSOCOM—US Special Operations Command
Vo—leaflet sea level rate of fall
VD—vertical distance
VFR—visual flight rules
VMC—visual meteorological conditions
WX—weather
XCDS—extracted CDS

XCDS-HS—extracted CDS, high speed

(Added-AFSOC) XCDS-LS—Extracted Container Delivery System-Low Speed

ZAR—Zone Availability Report

Terms

Airdrop—An aerial resupply method used to deliver supplies and equipment to combat, combat support, or combat service support units when no other delivery method is possible.

Computed Air Release Point (CARP)—A computed air position where the first paratroop or cargo item is released to land on a specified impact point.

Container Delivery System (CDS)—CDS is designed to airdrop numerous individual containers, high velocity, low velocity, or HALO, and double containers at high or low velocity initiated primarily by gravity release .

Circular Error Average (CEA)—A computation used to track training data for each airdrop qualified crew member (primarily navigators or CSOs). Compute CEAs by averaging all the drop scores (in yards) for each category specified in **paragraph 1.6**.

Combination Drop—Airdrops during which parachutists exit from the aircraft ramp after equipment extraction or gravity release (e.g., Heavy Equipment, CDS, combat expendable platforms [CEPs], container ramp bundle).

(Added-AFSOC) Container Release System (CRS)—The CRS is a modification of HSLADS components without the sling and is used for low speed gravity drops.

Cross Track Drift Offset—The distance, perpendicular to DZ centerline, the aircraft tracks to compensate for drift effect incurred during parachute descent.

Deceleration Distance (DD)—This factor is for HALO only. The vertical distance, in feet, that the load descends from chute actuation to full canopy deployment.

Deceleration Time (DT)—This factor is for HALO only, the time, in seconds, that the load descends from chute actuation to full canopy deployment.

Deceleration Quotient (DQ)—A constant in seconds computed during airdrop tests that compensates for the nonlinear deceleration in forward speed of an airdropped load as it approaches stabilization. This factor is computed by subtracting exit distance from FTD and dividing the difference by effective ground speed of the aircraft. $DQ = (FTD - ED) / EGS$.

Deployed Drive Distance (DDD)—Maximum distance, in meters, that the fully deployed parachute can drive during the Deployed Drive Time due solely to the forward drive of the parachute (i.e., no wind effect). This is also the Maximum LAR radius.

Drift Effect—Horizontal distance traveled downwind by a load under full canopy.

(Added-AFSOC) Drop Zone Controller (DZC)—An individual on the DZ required to monitor all airdrop operations. Exception: Airdropping of unconventional warfare forces as defined by the Joint Strategic Capabilities Plan (JSCP) Annex E, does not require a DZC. AFI 13-217 defines DZC qualification duties and responsibilities.

Dropsonde—A wind measurement instrument that is deployed by an aircrew member during airdrop missions to generate a more accurate CARP for ballistic payloads or LAR for guided payload systems.

Drop Zone (DZ)—A specified area upon which airborne troops, equipment, or supplies are airdropped.

Effective Ground Speed (EGS)—A factor used during testing to determine DQ. Computed by applying the mean true wind between drop and stabilization altitude to the aircraft true airspeed (TAS) and true heading.

Exit Distance (ED)—The ground distance traveled by the aircraft during airdrop initiation. This distance measured along DZ axis from the initiation, green light signal, to the exit of the first object from the aircraft.

Exit Time (ET)—The elapsed time, in seconds, from the green light signal to the exit of the first object from the aircraft.

Flight Station—An internal aircraft reference system, expressed in inches, referenced from an imaginary reference point in front of the aircraft. Fuselage station location for airdrop of equipment refers to the load's center of gravity.

Forward Travel Distance (FTD)—The ground distance traveled by the airdropped load from the green light signal to stabilization. Plot FTD back from the point-of-impact (PI) along DZ axis.

Forward Travel Time (FTT)—Exit time plus deceleration quotient. A time constant that compensates for the horizontal distance the object travels from the green light signal until reaching stabilization. This factor is used to compute FTD.

Ground Radar Aerial Delivery System (GRADS)—A method to position the aircraft for the airdrop (usually at high altitude) by using a ground based radar.

High Altitude High Opening (HAHO)—A high altitude airdrop in which parachutes deploy immediately upon exit from the aircraft.

High Altitude Low Opening (HALO)—A high altitude airdrop in which a period of freefall precedes actuation of the parachute(s). Does not include high altitude CDS using high velocity ring-slot parachutes (HVCDS).

High Altitude Release Point (HARP)—HALO or HAHO only. A point in space, computed by any means, over which the aircraft must be positioned at the time of release to ensure the load impacts the desired point on the ground.

High Speed Low Level Aerial Delivery System (HSLADS)—A sling airdrop system employed to allow the aircraft to deliver loads at speeds up to 250 KIAS or KCAS and at minimum altitudes to as low as 250 feet AGL. (MC-130).

High Velocity Rate of Fall—This factor is the rate of fall in feet per second derived from parachute ballistic data, corrected for sea level standard day.

Initial Point (IP)—A well-defined point, easily distinguishable visually and/or electronically, used as a starting point for the run-in to the DZ.

Military Free Fall (MFF)—MFF is an employment concept encompassing both HALO and HAHO techniques of parachuting.

Military Information Support Operations (MISO)—Planned operations to convey selected information and indicators to foreign audiences to influence their emotions, motives, objective reasoning, and ultimately the behavior of foreign governments, organizations, groups, and individuals in manner favorable to the originator's objectives. Also called PSYOPS.

Mean Effective Wind (MEW)—An average wind direction and speed measured from the DZ surface to drop altitude as calculated by the DZC.

Parachute Deployment—The stage in the airdrop process when a parachute has achieved its full opening potential.

Point of Impact (PI)—The specified location on the DZ where the targeted airdrop load or jumper is expected to land.

Radar-Verified Airdrop (RVAD)—RVAD is a term to describe a precise method to verify or update the aircraft's navigational solution using the radar and offset aim points, regardless of GPS denial or degradation. Apply SCNS radar updates in accordance with T.O. 1C-130-1-4, *C-130 Aircraft with Self Contained Navigation System*. This has replaced the procedures formerly known as the Adverse Weather Aerial Delivery System (AWADS).

Raised Angle Marker (RAM)—A “tented” panel device used in marking the intended PI of the DZ that enhances DZ acquisition.

Rate of Fall (RoF)—RoF is the vertical velocity, in feet per second, of the airdropped load while under full parachute canopy. RoF is corrected to a standard day sea-level rate.

Safety Zone—A distance established by agreement between the air mission commander and the supported forces' commander subtracted from the DZ trailing edge to reduce the potential for off-DZ drops. For peacetime personnel airdrops, the safety zone is typically 200 yards. Do not compute safety zone distances for airdrops supporting unconventional warfare forces as defined by the Joint Strategic Capabilities Plane Annex E, or HALO or HAHO airdrops. **Exception:** With concurrence of the user, AFSOC and ACC units are not required to use a safety zone when dropping US Special Operations Forces (SOF) and/or Guardian Angel (GA) personnel.

Sequential Drop—Two or more extracted platforms released on a single pass over the DZ. Each platform, in turn, deploys the extraction parachute of the following platform.

Sight Angle—The angle, in degrees below horizontal, along which the aircrew member, who initiates the airdrop release, sights a point on the ground. This ground reference is used in determining the initiation of the airdrop release sequence.

Stabilization—Stabilization is the point in the drop sequence where descent is within 10 percent of a constant standard day sea-level rate of fall. Normally, forward velocity has decreased to zero.

Stabilization Altitude—The altitude, in feet Above Ground Level (AGL), where stabilization occurs.

Stabilization Time—Stabilization Time is the elapsed time from load exit to stabilization. Computation of Time of Fall Constant (TFC) also uses this factor.

Stick—Number of parachutists or CDS loads exiting one side of the aircraft in one pass over the DZ.

Timing Point (TP)—Any visual or electronic reference used to measure the beginning of the release sequence. The timing point should be as close to the release point as possible for maximum accuracy.

Time of Fall Constant (TFC)—A constant in seconds computed during airdrop tests that compensates for the nonlinear rate of fall from load exit to stabilization. This factor is used to determine drift effect during stabilization.

Total Wind Effect (TWE)—Total distance, in meters, that the parachute or load travels by the effects of the wind.

Tow Plate—A primary aircraft component used to control the equipment airdrop sequence. This assembly allows for the transfer of force of the extraction chute from the tow plate, connected to the aircraft, to the airdrop load. In the event of an extraction chute malfunction, the tow plate assembly allows for the release of the chute without transferring the extraction force to the airdrop load.

Vertical Distance (VD)—The distance, in feet, a load falls after exiting the aircraft and prior to stabilization.

Verbally Initiated Release System (VIRS)—VIRS is a method of positioning aircraft for airdrop by verbal instruction from the DZC. Refer to AFI 13-217, *Drop Zone and Landing Zone Operations*.

Visual and Verbal Signals—Green Light—Verbal command and/or aircraft indicator light used to announce the arrival of the aircraft at the air release point. This action signals the start of the usable DZ time. **Red Light**—Verbal command and/or aircraft indicator light used to announce the end of useable DZ time.

Attachment 2

ALTERNATIVE COMPUTED AIR RELEASE POINT SOLUTIONS

A2.1. General. With the development of new equipment and procedures, additional methods of CARP solutions have been designed. This attachment offers additional techniques and tabulated data as aids to expedite the solution of the final CARP close-in to the DZ.

A2.2. Wind Circle Solution. The wind circle solution is designed to permit the aircrew member to evaluate wind conditions very close to the DZ and at levels other than drop altitude. All work in constructing the wind circle is done on the ground. The drift effect for three or more wind velocities (usually 10, 20, and 30 knots) is drawn on the DZ depiction centered on the PI, or on the FTD plot. Wind circles may also be constructed using any convenient distance increment (usually 200 yards). A true or magnetic north arrow is drawn through the center of the circle with azimuth lines, normally at 30 degree increments, around the circle to facilitate speedy plotting of wind directions. In-flight, the aircrew member determines winds, plots them on the wind circle, and applies FTD (if required) to provide an instantaneous CARP. It is possible to completely re-evaluate the CARP inside the one-minute advisory.

A2.2.1. Preflight.

A2.2.1.1. Select a properly scaled DZ chart, photograph, or drawing. The wind circle may be drawn on clear acetate or similar material for reproduction. These reproductions may be attached to DZ photos for in-flight use.

A2.2.1.2. Complete the AF Form 4018. TTF is needed to construct the wind circle, except when constant wind circle spacing is used.

A2.2.1.3. Determine the drift effect for a 10 knot wind using the formula:

$$\text{TTF (Item 19)} = \frac{\text{(Drift Effect)}}{10 \text{ knots}}$$

$$1.78 \text{ yards} = \frac{\text{Drift Effect}}{10 \text{ knots}}$$

A2.2.1.4. Draw circles on the DZ depiction representing the drift effect for selected wind velocities up to 40 knots. Wind circles should be centered on the PI. It may be centered on the FTD plot, but an error is induced along the run-in axis for any in-flight change from the original preflight value of groundspeed used to make the plot. Even though small errors (2.8 yards each second of FTT for each 5 knots change in preflight CARP groundspeed) are induced by positioning the wind circles on the FTD plot, such errors may be acceptable in relation to possible plotting and computation errors made possible by attempting to do so in-flight.

A2.2.1.5. Draw azimuth lines from the PI or FTD plot outward to the outer circle each 30 degrees or selected increment. Label each with the appropriate value. Magnetic values are desirable since DZCT winds are passed as magnetic values.

A2.2.1.6. Label the DZ depiction or acetate overlay with the constants used to construct the wind circles, i.e., type parachute, load weight, TTF, or size of constant wind circles used. The aircrew member should always re-compute the CARP before each mission to verify the wind values.

A2.2.1.7. Plot the preflight drift effect from the PI or FTD plot.

A2.2.1.8. Measure the distance from the end of the drift effect plot or the CARP to the timing line and convert to time using the preflight groundspeed. If the wind circle is centered on the FTD plot, the result is the timing point time. If the wind circle is centered on the PI, subtract the FTT from this time. The result is the timing point time.

A2.2.2. In-flight wind determination.

A2.2.2.1. The wind circle allows aircrew members to average and plot a number of different winds with relative ease and speed. These include surface, intermediate, mean-effective, drop altitude, forecast, and estimated winds. The aircrew member is encouraged to obtain and plot several winds from different sources in order to get the best picture possible of actual wind conditions. The decision on which wind or combination of winds to use is up to the individual. Aircrew members must insure they compute drop altitude drift and groundspeed for line up and timing. **(T-3)**. During combat conditions, drift effect is normally plotted based on an average of surface wind indications and navigation computer readouts.

A2.2.3. Sample problem.

A2.2.3.1. **Figure A2.2.** was constructed using the following information from an AF Form 4018 computation:

A2.2.3.1.1. Parachute - T-10.

A2.2.3.1.2. Weight - 250 lbs

A2.2.3.1.3. TTF - 51.6 secs

A2.2.3.1.4. FTD - 235 yards

A2.2.3.1.5. Ballistic wind - 250°/10 knots

$$\frac{51.6}{1.78 \text{ yards}} = \frac{(289)}{10}$$

A2.2.3.1.6. Groundspeed - 130 knots

A2.2.3.2. The drift effect for a 10 knot wind equals 289 yards.

Figure A2.1. Wind Circle Sample.

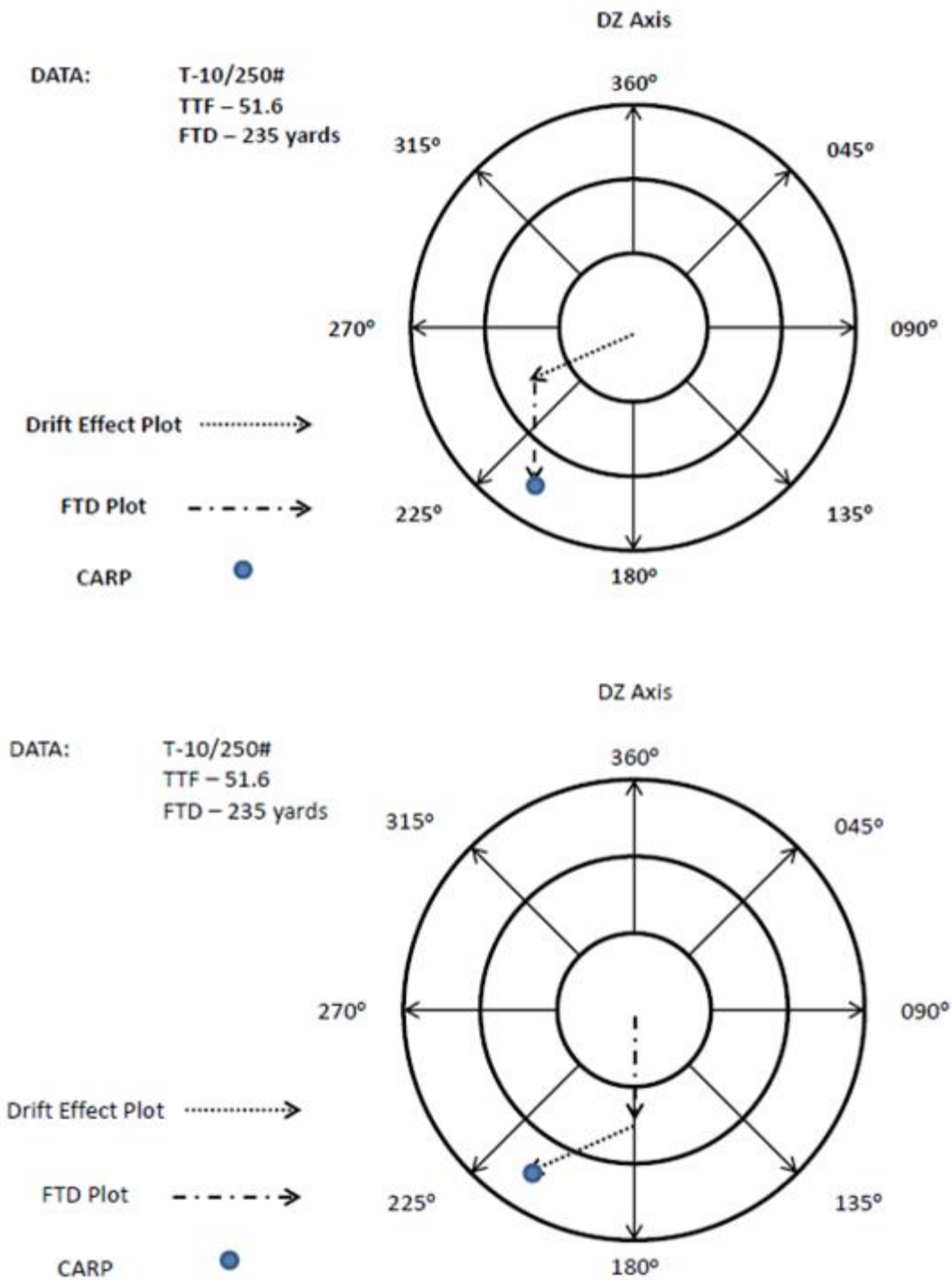

A2.3. Sight Angle Techniques. Another variation of timing graphs is shown in this example problem:

A2.3.1. Complete AF Form 4018 per [Chapter 4](#) given the following:

- A2.3.1.1. Drop altitude - 650 feet AGL.
- A2.3.1.2. Highest terrain elevation on DZ - 1443 feet MSL.
- A2.3.1.3. True altitude - 2093 feet MSL.
- A2.3.1.4. PI elevation - 1443 feet MSL.
- A2.3.1.5. Load - SATB-H.
- A2.3.1.6. Wind - 358/08.
- A2.3.1.7. Groundspeed - 162 Knots.
- A2.3.1.8. FTT - 1.9 Seconds.
- A2.3.1.9. Usable DZ length - 1200 yards.
- A2.3.1.10. Determine altitude above the PI using AF Form 4018 block 14.
- A2.3.1.11. Determine aircraft deck angle from appropriate weapon system technical order or aircraft manual. For this example, assume two degrees.
- A2.3.1.12. Determine timing point. For this example, assume the PI is the timing point.
- A2.3.1.13. Use the formula for sighting distance:

$$D = (\text{Tangent } @) \times (A/3)$$

D = Distance measured directly below the flight deck at the moment the designated target intersects an internal reference point.

@ = Angle of inclination from flight deck to designated target.

A = Absolute altitude in feet AGL above the designated target.

Note: Angle @, is measured using a clinometer or is specified through established techniques for each aircraft.

Figure A2.2. Sight Angle Timing Graph CARP Sample.

COMPUTED AIR RELEASE POINT COMPUTATIONS						DATE	
NAVIGATOR'S NAME (Print)			CALL SIGN	ORGANIZATION	NAVIGATOR'S SIGNATURE		
ROBERTA FOSTER			HAVOC 25	39 AS	Roberta Foster		
FACTORS		DATA	DROP DATA	RESULTS			
1	DROP ALTITUDE	650			PREFLIGHT ALTIMETER SETTING	30.20	
2	TERRAIN ELEVATION +	1750			DROP ZONE	Bronte	
3	TRUE ALTITUDE	2400			SCHEDULED DROP TIME(S)	2345	
4	PRESSURE ALTITUDE VARIATION + A	-280			LOAD	SATB-H	
5	PRESSURE ALTITUDE	2120			LOAD WEIGHT	15 lb	
6	CORRECTED DROP ALTITUDE B	720			PARACHUTE (Type and number)	68"	
7	TERRAIN ELEVATION +	1750			FLIGHT STATION OF LOAD	bomb rack	
8	INDICATED ALTITUDE	2470					
9	TRUE ALTITUDE TEMPERATURE	+2			$\frac{29.92}{(\quad)} = \frac{30.20}{29.92}$		
10	IAS/CAS/EAS	140/142			$+ \quad = \quad -28$		
11	TRUE AIRSPEED	139			$\frac{\text{Temperature}}{\text{Pressure Altitude}} = \frac{\text{Drop Altitude}}{\text{(Corrected Drop Altitude)}}$		
12	RATE OF FALL	23.8			$\frac{\text{Average Temperature}}{\text{Average Pressure Altitude}} = \frac{\text{(Adjusted Rate of Fall)}}{\text{Rate of Fall}}$		
13	ADJUSTED RATE OF FALL C	23.2			$\frac{\text{Adjusted Rate of Fall}}{\text{Stabilization Altitude}} = \frac{1.0}{\text{(Time of Fall)}}$		
14	ALTITUDE ABOVE POINT OF IMPACT D	663			$\frac{\text{Total Time of Fall}}{1.78 \text{ yds}/1.94 \text{ mtrs.}} = \frac{\text{(Drift Effect)}}{\text{Wind Speed}}$		
15	VERTICAL DISTANCE	0			$\frac{\text{Groundspeed}}{1.78 \text{ yds}/1.94 \text{ mtrs.}} = \frac{\text{(Forward Travel Distance)}}{\text{Forward Travel Time}}$		
16	STABILIZATION ALTITUDE	663			$\frac{\text{Groundspeed}}{1.78 \text{ yds}/1.94 \text{ mtrs.}} = \frac{\text{Distance}}{\text{(Time)}}$		
17	TIME OF FALL E	28.5			Usable DZ Remaining (PI to TE) 1030		
18	TIME OF FALL CONSTANT +	0			Minus Safety Zone Distance 0		
19	TOTAL TIME OF FALL	28.5			Usable Drop Zone Length 1030		
20	BALLISTIC WIND	350/08					
21	DRIFT EFFECT F	128					
22	DROP ALTITUDE WIND	350/10					
23	MAG/TRUE COURSE	112					
24	DRIFT CORRECTION	-3					
25	MAG/TRUE HEADING	109					
26	GROUND SPEED	144					
27	EXIT TIME	1.9					
28	DECELERATION QUOTIENT +	0					
29	FORWARD TRAVEL TIME	1.9					
30	FORWARD TRAVEL DISTANCE G	154					
31	STOP WATCH DISTANCE						
32	STOP WATCH TIME H						
33	USABLE DROP ZONE LENGTH I	1030					
34	USABLE DROP ZONE TIME H	12.7					
35	RED LIGHT TIME (32 PLUS 34)						

AF IMT 4018, 19980501, V2

Replaces AMC Form 512, Apr 93, which is obsolete.

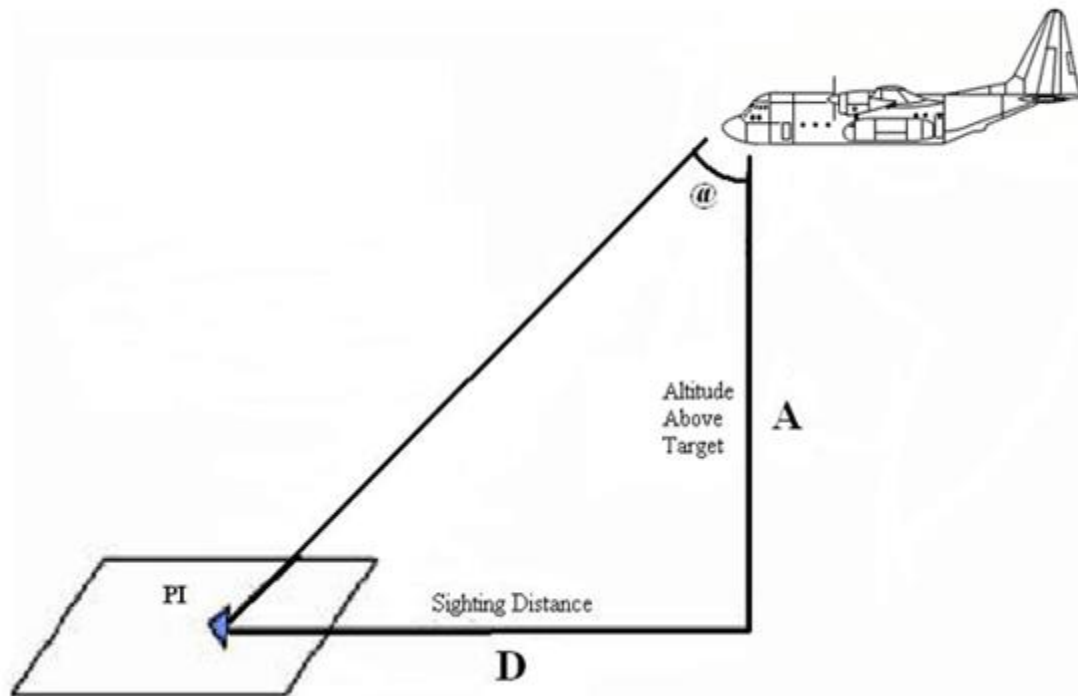
Figure A2.3. Aircraft Sight Angle Timing Graph Diagram.

A2.3.1.14. The bottom line of the grid represents the timing reference point.

A2.3.2. Plot the sighting distance (D from [paragraph A2.3.1.13](#)) along the DZ axis from the bottom of the graph in [Figure A2.4](#) towards to the top of the graph.

A2.3.3. Draw wind circles (based on TTF and formula F on the AF Form 4018 in 10, 20, 30, and 40 increments) from the point determined by [paragraph A2.3.2](#) ([Figure A2.5](#)).

A2.3.4. Plot the CARP based on the preflight winds ([Figure A2.6](#)).

A2.3.5. Measure from the CARP to the right until it intersects with the preflight groundspeed. From this intersection, parallel the timing lines up and over to determine the graph time. For this example the time equals 9.0 seconds.

A2.3.6. Enter this value in the graph time block at the bottom of the form.

A2.3.7. Extract the FTT from the AF Form 4018, Block 29, and enter it in the FTT block at the bottom the form.

A2.3.8. Subtract the FTT from the graph time to obtain a stopwatch time.

A2.3.9. Extract the Usable DZ Time from the AF Form 4018, Block 34, and enter it in the appropriate block at the bottom of this form.

A2.3.10. Add the Stopwatch Time to the Usable DZ time to obtain a running Red Light Time measured from your timing point.

A2.3.11. Modifications to this technique include the following:

A2.3.11.1. Delete the Usable DZ Time entry from the bottom of the chart and restart the timing for the designated red light time.

A2.3.11.2. Plot not only the wind but also the FTD on the wind circle. When using this option, remember not to subtract the FTT. The graph time automatically equals the stopwatch time.

Figure A2.4. Sight Angle Timing Graph Sample (Part 1).

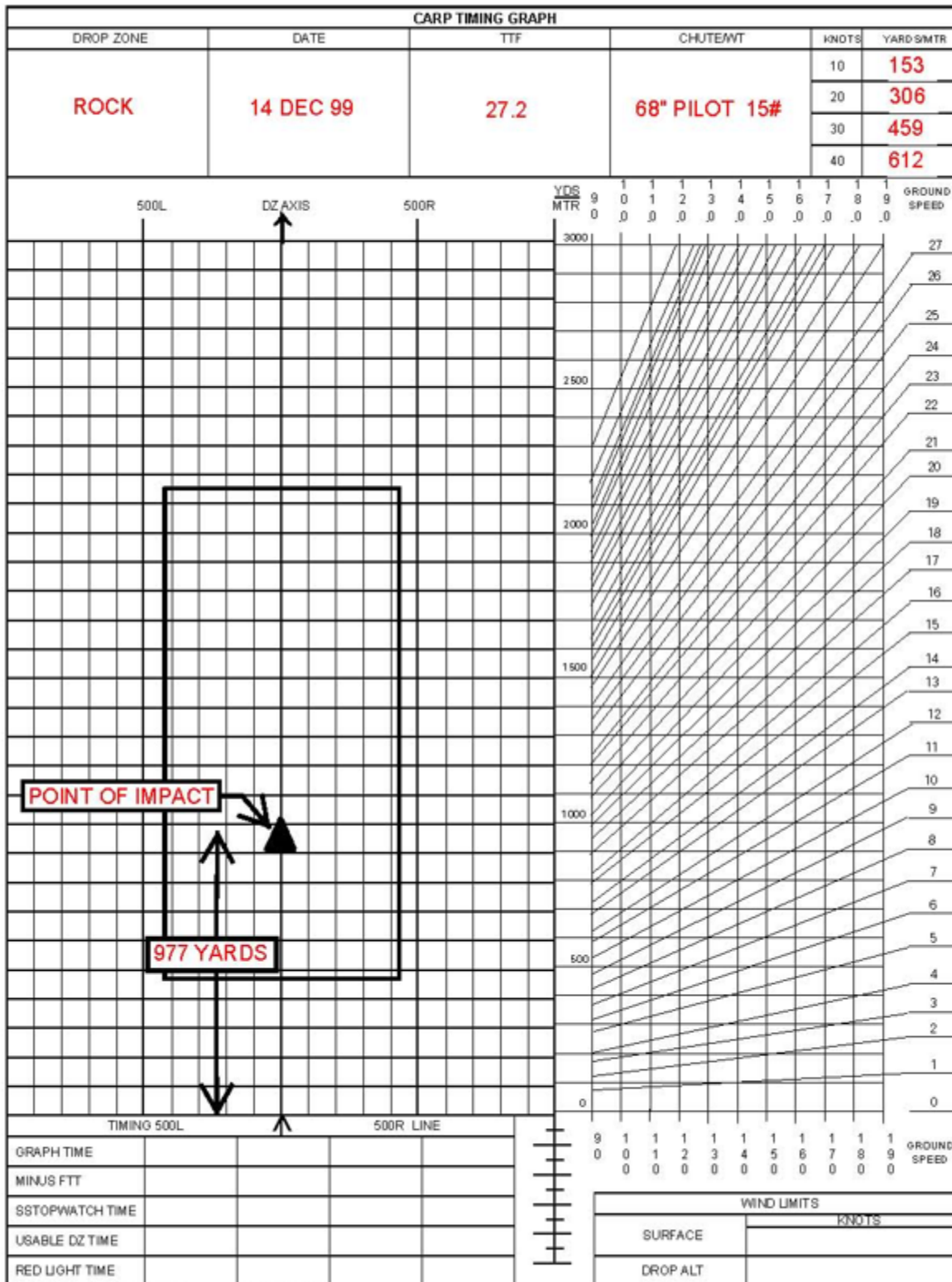

Figure A2.5. Sight Angle Timing Graph Sample (Part 2).

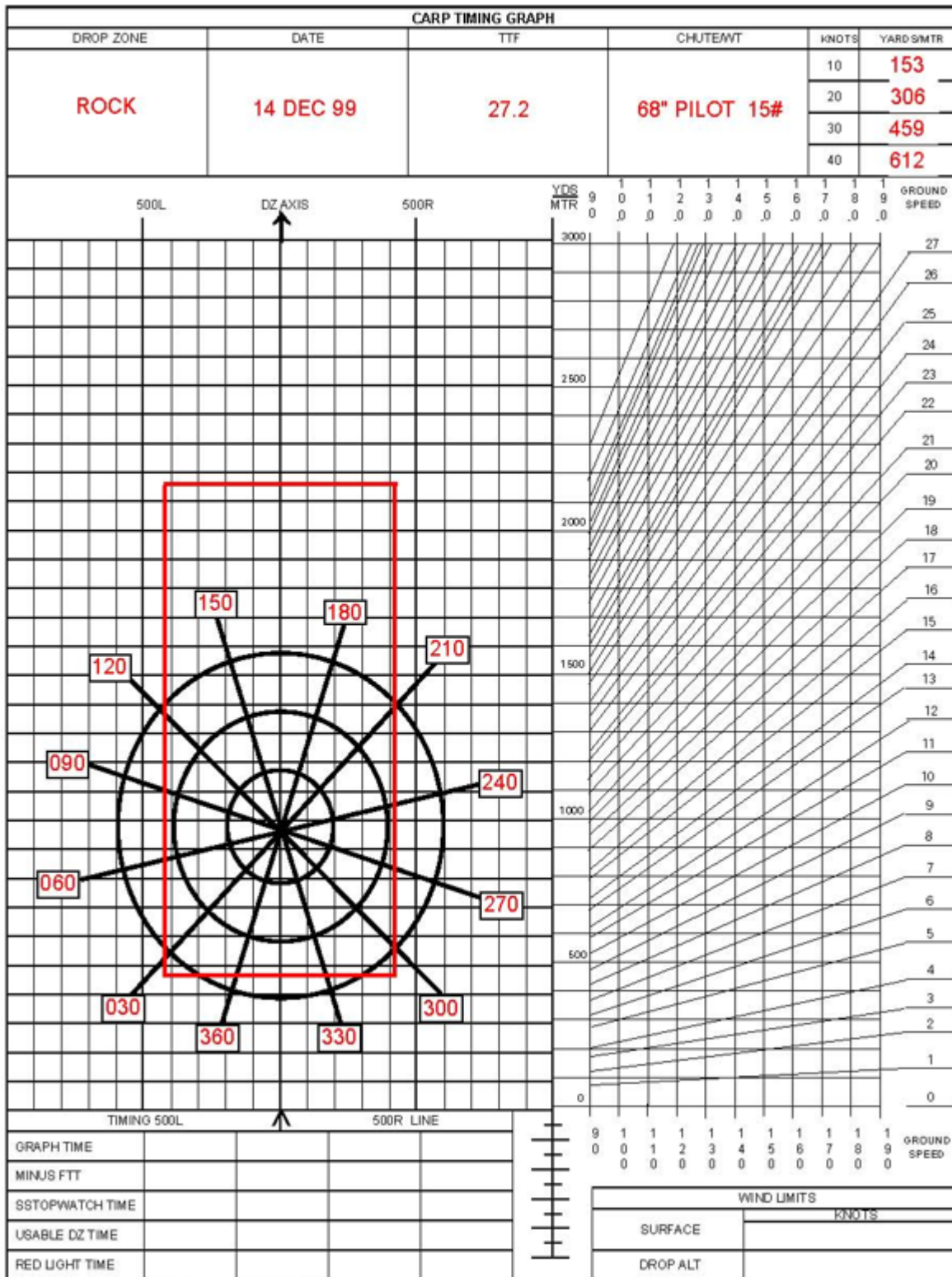
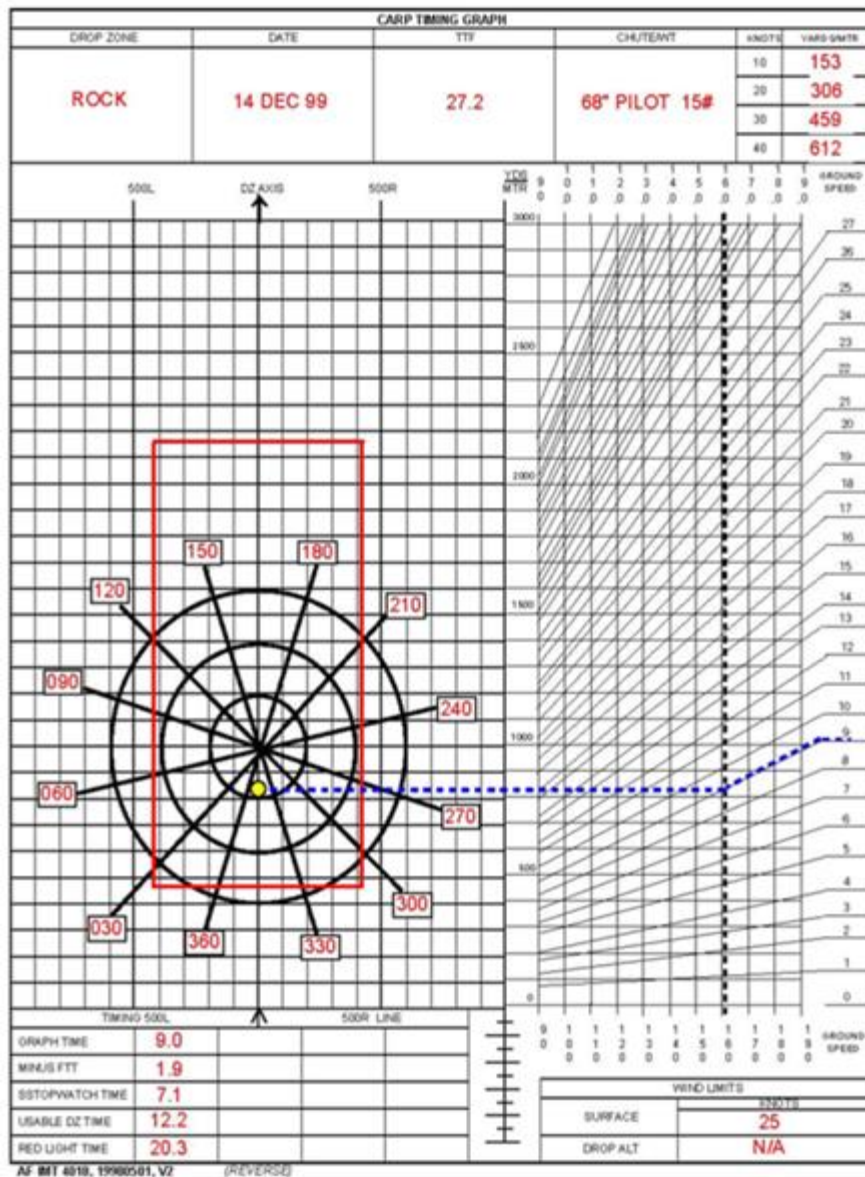

Figure A2.6. Sight Angle Timing Graph Sample (Part 3).



A2.4. In-flight Forms Completion. The actual in-flight data block is the same for both the AF Form 4013, *Modified CARP Solution*, and the AF Form 4018.

A2.4.1. Actual data. Record the reported surface, mean effective wind, and the actual altitude wind at the time of the drop. Indicate the source of the wind if other than CCT or STS.

A2.4.2. Drop data. Should contain the data actually used to compute the updated CARP in-flight.

A2.4.2.1. Ballistic wind. Wind used to compute the drift effect. Indicate whether measured (M) or interpolated (I).

A2.4.2.2. Ground speed. Ground speed used to compute the FTD and usable DZ time in-flight. Indicate whether computed by the aircrew member (C), displayed by INS, GPS,

Doppler (D), or obtained from formation lead in a station keeping equipment (SKE) formation (S).

A2.4.2.3. Drift. Drift angle used to compute SKE offset. Indicate whether computed by the aircrew member (C), displayed by INS, GPS, Doppler (D), or obtained from formation lead in a SKE formation (S).

A2.4.2.4. Green light time. Actual elapsed time, in seconds, from the timing point to the release point for a visual drop, or from lead's EXECUTE to the wingman's release point for a SKE drop. Use this block to indicate release method (R for RVAD, S for SKE, and V for Visual) as well.

A2.4.2.5. Red light time. Actual elapse time, in seconds, from release point to "red light" call.

A2.5. Post Flight Forms Completion.

A2.5.1. TOT. Record actual time over target (TOT) (for formation lead).

A2.5.2. Formation position. Record element and position within that element. Also indicate whether it was a SKE (S) or visual (V) formation. SS indicates single ship.

A2.5.3. Raw circular error. Reported drop score. Enter "Sat" or "Unsat" for mass tactical drops. For multiple passes, only the first score is recorded.

A2.5.4. Corrected circular error. Raw circular error corrected in accordance with applicable Air Force Manual (AFMAN) 11-2C-MDS V1 requirements to be annotated on the AF Form 4012. Turn in completed AF Form 4012 to the squadron for the score to be entered into the crewmember and/or aircraft individual circular error record.

A2.5.5. Turn in the AF Form 4015 and AF Form 4018 to the unit tactics office at the completion of the mission. (Not applicable to AFSOC).

Attachment 3 (Added-AFSOC)

SAMPLE COMPLETED AF FORM 4011 LOW ALTITUDE LEAFLET FORM.

Figure A3.1. (AFSOC) AF Form 4011 Low Altitude Leaflet Computation.

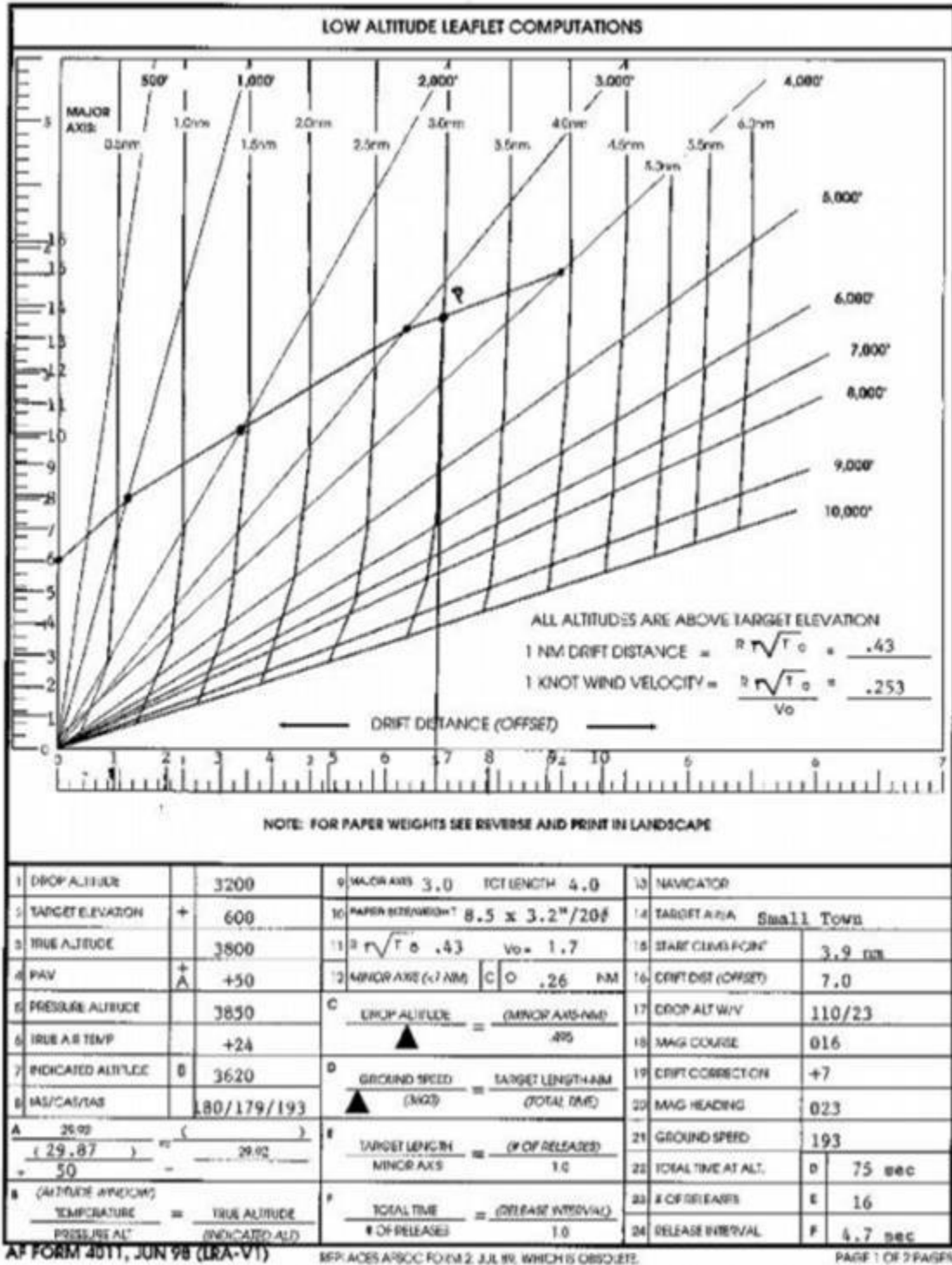

Attachment 4 (Added-AFSOC)

TARGETING CENTER STICK MINIMUM DZ SIZE TABLES.

Table A4.1. (AFSOC) Targeting Center Stick Minimum DZ Size Tables.

TARGETING CENTER STICK MINIMUM DZ SIZE					
ALTITUDE (AGL)	WIDTH	LENGTH			
C-130 CDS / CRS / CRL / LCADS-LV / LCLA					
To 600 feet	400 yds / 366 m	Single Containers	Double Containers	Length Prior to PI	Length Past PI
		1	1-2	200 yds / 183 m	200 yds / 183
		2	3-4	225 yds / 206 m	225 yds / 206
		3	5-6	250 yds / 229 m	250 yds / 229
		4	7-8	275 yds / 252 m	275 yds / 252
		5-8	9-16	350 yds / 320 m	350 yds / 320
		9-12	10-24	425 yds / 389 m	425 yds / 389
Above 600 feet	Add 40 yds / 36 m to width and length for each 100 feet above 600 feet (add 20 yds / 18 m to each side of DZ, 20 yds / 18 m to each end).				
HVCDS (using 12, 22, or 26 foot ring slot parachutes) / LCADS-HV					
To 3000 feet	580 yds / 530 m	Length Prior to PI		Length Past PI	
		330 yds / 204 m		330 yds / 204 m	
		Add 25 yds / 23 m to leading edge for each additional row of containers		Add 25 yds / 23 m to trailing edge for each additional row of containers	
Above 3000 feet	Add 25 yds / 23 m to each side and 100 yds / 91 m to each end for every 1000 feet increase in drop altitude.				
HSELLADS					
All	300 yds / 274 m	Length Prior to		Length Past PI	
		300 yds / 275 m		300 yds / 275 m	

Personnel (Static Line)			
		Length Prior to PI	Length Past PI
		300 yds / 275 m	300 yds / 275 m
To 1000 feet	600 yds / 549 m	Add 38 yds / 35 m to the leading edge for each additional parachutist. Add additional 200 yds / 91 m to leading edge for safety zone, if required.	Add 38 yds / 35 m to the trailing edge for each additional parachutist. Add additional 200 yds / 91 m to trailing edge for safety zone, if required.
Above 1000 feet	Add 30 yds / 28 m to width and length for each 100 feet above 1000 feet (add 15 yds / 14 m to each side of DZ, 15 yds / 13 m to each end).		