

**BY ORDER OF THE  
SECRETARY OF THE AIR FORCE**



**DEPARTMENT OF THE AIR FORCE  
MANUAL 13-217**

**22 APRIL 2021**

*Incorporating Change 1, 19 APRIL 2022*

***Nuclear, Space, Missile, or Command and  
Control***

***DROP ZONE, LANDING ZONE, AND  
HELICOPTER LANDING ZONE  
OPERATIONS***

**COMPLIANCE WITH THIS PUBLICATION IS MANDATORY**

---

**ACCESSIBILITY:** Publications and forms are available on the e-Publishing website at [www.e-Publishing.af.mil](http://www.e-Publishing.af.mil) for downloading or ordering.

**RELEASABILITY:** There are no releasability restrictions on this publication.

---

OPR: AF/A3S

Certified by: AF/A3S  
(Brig Gen. Palenske)

Supersedes: AFI13-217, 10 May 2007

Pages: 159

---

This publication implements Air Force Policy Directive (AFPD) 13-2, *Air Traffic Control, Airfield, Airspace, and Range Management* and Air Force Instruction (AFI) 11-200, *Aviation Management*. It provides guidance and procedures for Drop Zone (DZ) and Landing Zone (LZ) operations, and directs DZ, LZ, and Helicopter LZ (HLZ) survey and assessment procedures and processes. It applies to individuals at all levels who are civilian employees or members of the Regular Air Force (RegAF), U.S. Space Force (USSF), Air Force Reserve (AFR), the Air National Guard (ANG), and those who are contractually obligated to comply with Department of the Air Force publications, except where noted otherwise. For the purposes of this Department of the Air Force Manual (DAFMAN), all references to Major and Field Commands (MAJCOMs / FLCOMs) are intended to also reference or include Direct Reporting Units, Field Operating Agencies, and the ANG. Ensure all records created as a result of processes prescribed in this publication are maintained in accordance with Air Force Instruction (AFI) 33-322, *Records Management and Information Governance Program*, and disposed of in accordance with the Air Force Records Disposition Schedule located in the Air Force Records Management System. Refer recommended changes and questions about this publication to the Office of Primary Responsibility (OPR) listed above using the Air Force (AF) Form 847, *Recommendation for Change of Publication*; route AF Forms 847 from the field through the appropriate chain of command. This publication may be supplemented at any level, but all supplements must be routed to the OPR listed above for coordination prior to certification and approval. **(T-1)**. Send recommended supplements to

Headquarters Air Force Special Warfare Directorate (AF/A3S) at [AF.A3S.Workflow@us.af.mil](mailto:AF.A3S.Workflow@us.af.mil) or to AF/A3S, 1480 Air Force Pentagon, Washington, DC 20330-1480. The authorities to waive wing/unit level requirements in this publication are identified with a Tier (“T-0, T-1, T-2, T-3”) number following the compliance statement. See Department of the Air Force Instruction (DAFI) 33-360, *Publications and Forms Management* and [paragraph 1.4](#) for descriptions of the authorities associated with the Tier numbers. Submit requests for waivers through the chain of command to the appropriate Tier waiver approval authority, or alternately, to the requestors commander for non-tiered compliance items. Compliance with the attachments in this publication is mandatory. For further information regarding waivers, see [paragraph 1.4](#) of this publication. The use of the name or mark of any specific manufacturer, commercial product, commodity or service in this publication does not imply endorsement by the DAF.

## **SUMMARY OF CHANGES**

This interim change revises DAFMAN 13-217 by (1) correcting the email addresses to which SOCOM Form 111 is submitted to AFSOC, (2) updating Table 3.1, *Standard DZ Size Criteria*, Notes 2 and 4 to clarify to which flying platforms and under what circumstance exemptions apply, (3) updating [Table 3.2](#), *Standard Point of Impact Placement*, to clarify criteria for C-130 aircraft, (4) updating and clarifying the International Agreements applicable to non-US personnel involved in drop zone operations. A margin bar (|) indicates newly revised material.

<b>Chapter 1—OVERVIEW</b>	<b>6</b>
1.2. International Agreements.....	6
1.3. Deviations.....	6
1.4. Waivers.....	6
1.5. Contractor Support and Limitations.....	7
<b>Chapter 2—ZONE AVAILABILITY MANAGEMENT SYSTEM</b>	<b>8</b>
2.2. Database.....	8
2.3. Roles and Responsibilities.....	9
2.4. Support.....	10
<b>Chapter 3—DROP ZONE OPERATIONS</b>	<b>11</b>
3.1. General.....	11
3.2. Responsibility.....	11
3.3. DZ Criteria.....	11
Table 3.1. Standard DZ Size Criteria. (Note 1) .....	12
Table 3.2. ....	15
Figure 3.1. Circular DZ Computation.....	19
Figure 3.2. Area DZ.....	19

	3.4.	Instrument Meteorological Condition Airdrops.....	21
	3.5.	Hazards, Obstacles, and Restrictions. ....	21
	3.6.	Airdrop Winds. ....	22
Table	3.3.	Surface Wind Limits for CDS/Equipment Airdrops.....	23
Table	3.4.	Surface Wind Limits for USAF Personnel Airdrops. ....	23
	3.7.	DZ Markings.....	24
Figure	3.3.	Standard DZ Markings.....	25
Figure	3.4.	MFF DZ Markings.....	26
	3.8.	Airdrop Communications. ....	27
	3.9.	Control Point Location.....	28
	3.10.	En Route and Terminal Navigational Aids. ....	28
	3.11.	GMRS. ....	28
Figure	3.5.	Ground Marked Release System Day and Night Markings.....	29
	3.12.	Verbally Initiated Release System. ....	29
	3.13.	DZ Personnel. ....	29
	3.14.	DZ Scoring.....	35
	3.15.	Off DZ and Airdrop Malfunction Reporting Procedures.....	36
	3.16.	DZ Surveys. ....	37
<b>Chapter 4—LANDING ZONE OPERATIONS</b>			<b>42</b>
	4.2.	Responsibilities.....	42
	4.3.	LZ Minimums. ....	44
Table	4.1.	Minimum LZ Runway/Taxiway Length/Width for Standard Traffic.....	47
Table	4.2.	LZ Runway Slopes, Overruns and Vertical Obstruction Clearances. ....	48
Figure	4.1.	LZ Approach/Departure Vertical Obstruction Clearances.....	50
Figure	4.2.	A and B Zone Vertical Obstruction Clearances.....	51
	4.4.	LZ Markings. ....	55
Figure	4.3.	AMP-1 Day.....	57
Figure	4.4.	AMP-1, Night/Instrument Approach.....	58
Figure	4.5.	AMP-2, Day.....	58
Figure	4.6.	AMP-2 Night. ....	59
Figure	4.7.	AMP-3, Day.....	59
Figure	4.8.	AMP-3, Night. ....	60
	4.5.	Unmarked LZ.....	60

	4.6.	LZ Communications. ....	60
Table	4.3.	Standard Air Traffic Control Light Signals. ....	61
	4.7.	LZ Control Point Location.....	61
	4.8.	LZ Personnel.....	61
	4.9.	LZ Personnel Qualification Training, Certification and Continuation Training.....	65
	4.10.	LZ Surveyors. ....	66
	4.11.	Quality Check. ....	68
	4.12.	Safety of Flight Review. ....	68
	4.13.	LZ Survey Approval. ....	70
<b>Chapter 5—HELICOPTER LANDING ZONE OPERATIONS</b>			<b>71</b>
	5.2.	HLZ Survey Selection. ....	71
	5.3.	HLZ Markings. ....	71
	5.4.	HLZ Survey and Assessment Requirements.....	71
	5.5.	HLZ Survey Assessments/Updates.....	74
<b>Chapter 6—LC-130 SKIWAY AND SKI LANDING AREA CRITERIA</b>			<b>75</b>
	6.2.	Selection of LC-130 Landing Sites.....	75
	6.3.	LC-130 Polar LZs. ....	75
	6.4.	Maximum Aircraft Gross Weight. ....	75
	6.5.	Ski Landing Area. ....	75
Table	6.1.	Ice Weight Bearing Capacity. ....	76
	6.6.	Surface Suitability.....	76
	6.7.	Surface Preparation and Maintenance. ....	76
	6.8.	Ski Airfield Markings and Layout. ....	77
	6.9.	Ski Landing Area Control Officer (SLACO).....	78
Figure	6.1.	Skiway Lead-In Markings.....	79
Figure	6.2.	Skiway Edge Markings. ....	80
Figure	6.3.	Skiway Apron Layout. ....	81
Figure	6.4.	Skiway Marker Detail. ....	82
Figure	6.5.	Ski Landing Area Marking. ....	83
<b>Attachment 1—GLOSSARY OF REFERENCES AND SUPPORTING INFORMATION</b>			<b>85</b>
<b>Attachment 2—WIND/SEA STATE PREDICTION CHARTS</b>			<b>96</b>
<b>Attachment 3—STANDARD/METRIC CONVERSION CHART</b>			<b>98</b>

<b>Attachment 4—GUIDANCE CONCERNING AF FORM 3823, DZ SURVEY</b>	<b>99</b>
<b>Attachment 5—GUIDANCE CONCERNING AF FORM 3822, LZ SURVEY</b>	<b>105</b>
<b>Attachment 6—GUIDANCE CONCERNING AF FORM 4303, HLZ SURVEY</b>	<b>114</b>
<b>Attachment 7—GUIDANCE CONCERNING AF FORM 4304, DZ/LZ CONTROL LOG</b>	<b>125</b>
<b>Attachment 8—ADDITIONAL GUIDANCE CONCERNING TACTICAL LZ SURVEYS.</b>	<b>127</b>
<b>Attachment 9—ADDITIONAL GUIDANCE CONCERNING LZS</b>	<b>128</b>
<b>Attachment 10—ADDITIONAL GUIDANCE CONCERNING DZS</b>	<b>152</b>
<b>Attachment 11—SOCOM FORM 111</b>	<b>158</b>

## Chapter 1

### OVERVIEW

**1.1 Purpose.** This manual establishes AF/A3S as the DAF proponent for assault zones, to include DZs, LZs, HLZs, LC-130 skiways and ski landing areas. It provides administrative, management, and operational guidance for DAF and subordinate command assault zone surveys, operations, and training to standardize procedures, increase mission effectiveness and safety, and ensure compliance with Department of Defense (DoD) activity and mishap reporting requirements. Use this publication in conjunction with Air Force Manual (AFMAN) 11-2 Mission Design Series (MDS) publications and applicable DoD, United States Air Force (USAF), and MAJCOM instructions and directives. For the purposes of this document and consistent with AF doctrine, the term “Air Component Commander” is used to refer to either the Commander of Air Force Forces or the Commander of Air Force Special Operations Forces (COMAFSOF) as applicable based on who has OPCON of the DAF forces to which this manual applies.

**1.2. International Agreements.** The AF implements certain international military standardization agreements, to include North Atlantic Treaty Organization (NATO) Standardization Agreement (STANAG). NATO STANAGS are standardization documents that specify the agreement of member nations to implement a standard, in whole or in part, with or without reservations, in order to meet an interoperability requirement. This manual addresses standards to include, but not limited to: STANAG 3344, Tactics, Techniques, and Procedures for NATO Airborne Operations; STANAG 3345, Data/Forms for Planning Air Movements; and STANAG 3570, Drop Zones and Extraction Zones - Criteria and Markings. This manual assists to establish international standardization agreements.

**1.3. Deviations.** Do not deviate from the guidance in this DAFMAN without an approved waiver except when the situation requires immediate action to ensure safety. Units will report deviations to the MAJCOM or Air Component Stan/Eval office or functional equivalent, with Operational Control (OPCON) of the asset which conducted the deviation. MAJCOM, Air Component Stan/Eval office or functional equivalent with OPCON will notify the lead MAJCOM. **(T-1)**. Deviations resulting in a class A, B or C mishap, MAJCOMs will also report to AF/A3S at [AF.A3S.Workflow@us.af.mil](mailto:AF.A3S.Workflow@us.af.mil). **(T-1)**.

**1.4. Waivers.** Obtain a waiver if there is a requirement for a known or planned divergence from this DAFMAN. MAJCOM/Commanders (CCs) may designate the MAJCOM/Deputy Commander (CD) or MAJCOM/A3 as standard waiver authority for the T-1 level depending on the mission type. MAJCOM/CC may designate MAJCOM/CD, MAJCOM/A3, or first General Officer in Chain as standard waiver authority for T-2 level depending on the mission type. For the contents of this manual, standard waiver authority for T-2 level is the MAJCOM/A3, Air Component Commander, or designated authority, but no lower than the first General Officer in the chain of command or personnel meeting T-1 delegation authorization. The waiver authority will provide AF/A3S electronic copies of approved waivers, and notification upon waiver rescission, at AF/A3S at [AF.A3S.Workflow@us.af.mil](mailto:AF.A3S.Workflow@us.af.mil). **(T-1)**. Air Force Special Operations Command (AFSOC) crews may utilize standing Tier-2 waivers contained in surveys issued and/or approved by other MAJCOM/A3s, Air Component Commanders, or designated authorities. Crews must comply with all waiver restrictions and/or risk mitigation requirements. **(T-2)**. Other MAJCOM/A3, Air Component Commander, or designated authority may elect to accept Tier-2

waivers contained in surveys issued/approved by other MAJCOM/A3s, Air Component Commanders, or designated authorities if/as specified in a supplement to this DAFMAN.

**1.5. Contractor Support and Limitations.** The engagement of contractors in one or more of the roles contemplated by this issuance is subject to the limitation that contractors cannot perform inherently governmental functions. **(T-0)**. In general, this limitation precludes the use of contractors in certain operational contexts. Further, the use of contractors in operations in which the law of war applies may run the risk of classification as direct participants in hostilities. Commanders are to seek legal advice prior to utilizing contractors in operational contexts.

## Chapter 2

### ZONE AVAILABILITY MANAGEMENT SYSTEM

**2.1 General.** The zone availability management system is utilized by the DoD to request, process, and publish zone surveys for operations. This chapter directs access, procedures, requirements, and approval for zone use common to DZ, LZ, HLZ, and Forward Arming and Refueling Point (FARP) surveys. Chapters **3, 4, and 5** of this manual and AFI 11-235, *Specialized Fueling Operations*, direct specific procedures, requirements, and approval for each zone type use respectively. Conduct all airdrop, air land, and FARP operations at zones with a valid (approved and current) survey or other MAJCOM approved source document unless specifically documented in a later chapter of this manual or within AFI 11-235. **(T-2).**

**2.2. Database.** The Talon Point database contains worldwide valid DZ, LZ, light tactical fixed wing (LTFW) LZ, HLZ, and FARP surveys published for military users. Zone survey publication on Talon Point is not a requirement for operations, and valid surveys may be located on local or MAJCOM systems. The MAJCOM/A3, Air Component Commander, or designated authority shall ensure valid surveys are submitted to Talon Point. **(T-1).** **Exception:** Submission of tactical surveys and unmarked DZ surveys to Talon Point is not required. **NOTE:** Talon Point may be utilized to conduct survey workflow (submission, quality check, review, and approval or disapproval). It is the published FARP survey database, and meets the requirements to conduct FARP workflow in accordance with AFI 11-235. For assistance contact AFSOC Weapons and Tactics (AFSOC/A3TW) at [afsoca3.talonpoint.talonpoint@us.af.mil](mailto:afsoca3.talonpoint.talonpoint@us.af.mil).

2.2.1. UNCLASS Talon Point. Talon Point may be accessed on DoD non-classified internet protocol router network (NIPR) and/or civilian internet at <https://talonpoint.net> and has a scalable interface for mobile devices (e.g., smart phone, tablets, portable laptops). To access survey data, user must have an authorized account. **(T-1).** For access and, if required, workflow roles (i.e., author, quality control, safety of flight, approver, publisher, and administrator) users request accounts via the website or are added by a Talon Point administrator. Administrators will review all requests from personnel with a valid government email address and approve or deny accounts. **(T-2).**

2.2.2. Secret internet protocol router network (SIPR) Talon Point. Talon Point may be accessed on DoD SIPR at <https://talonpoint.snica.nro.smil.mil/TalonPoint/home>. and has a scalable interface for mobile devices (e.g., smart phone, tablets, portable laptops). On SIPR, a Talon Point account is not needed to access survey data. SIPR Talon Point accounts are only needed by users that require workflow roles (i.e., author, quality control, safety of flight, approver, publisher, and administrator). Users may request accounts via website or Talon Point administrators may establish user accounts. Administrators will review all requests from personnel with a valid government email address and approve or deny accounts. **(T-2).**



**2.3. Roles and Responsibilities.** Personnel in the roles defined below shall utilize Chapters **2, 3, 4, and 5** of this manual and AFI 11-235 to identify procedures, requirements, and approval for each zone type use. **(T-2)**. Workflow may be conducted via Talon Point or other means. However, all FARP workflow is via Talon Point, and AFSOC/A3TW is the FARP approval authority in accordance with AFI 11-235.

2.3.1. Requesting Units. Requesting units that task or request tasking of zone survey(s) will submit zone operation requirements within the task or survey request, to include all potential uses and users of the zone (e.g., ground units, flying units, supporting units, and aircraft types). **(T-2)**. Requesting units should task at the lowest level internally or submit request for zone survey support in accordance with **paragraph 2.4** Requesting units will ensure that a survey requirement exists, the surveyors receive the complete documented task (or that the complete documented task is submitted in the support request), and workflow is conducted by the appropriate safety of flight and approval authority. **(T-2)**.

2.3.2. Surveyors. Surveyors, (“Authors” on Talon Point), will submit survey(s) and notify appropriate quality check (or Ground Operations Approval, AF Form 3823, *Drop Zone Survey*, block 4C) personnel to conduct a review of the survey. **(T-3)**. Surveyors will include the received documented task with the survey and submit to quality check (or DZ ground operations approval) personnel. **(T-2)**.

2.3.3. Quality Check. Quality check personnel (or Ground Operations Approval personnel, AF Form 3823 block 4C), shall conduct an analysis of all surveys. **(T-2)**. Personnel must be a surveyor for the zone type (not the original surveyor) who will ensure the authored survey is complete, accurate, appropriate, and ready for submission to safety of flight. **(T-2)**. Tasked units may request an outside unit to conduct the quality check as desired or required. Quality check personnel will determine and submit survey to the appropriate safety of flight(s) based on the tasking, survey request and/or additional MAJCOMs as required for approval. **(T-2)**.

2.3.4. Flight Safety Review. Flight Safety reviewers shall accomplish a survey safety of flight review and submit the survey for approval, or reject to appropriate level for changes, within 60 days of receipt. **(T-3)**. MAJCOMs will assign offices with safety of flight duties. AFSOC conducts FARP reviews in accordance with AFI 11-235.

2.3.5. Approval Authority. The final approval authority shall accomplish a survey review and submit the survey for approval, disapproval, or rejection to appropriate level for changes within 60 days of receipt. **(T-3)**. MAJCOMs will assign offices with approval duties where appropriate.

2.3.6. MAJCOMs. MAJCOM/A3, Air Component Commander, or designated authority (Publishers, Talon Point) shall publish or submit for publication all approved or disapproved surveys in Talon Point. **Exception:** Tactical surveys and unmarked DZ surveys.

2.3.7. Publishers. Publishers may restrict survey access in Talon Point to designated organizations or individuals. Publishers should upload approved or disapproved surveys not in Talon Point for publication utilizing the by-pass workflow function, or submit a request for survey publication to AFSOC/A3TW at [afsoca3.talonpoint.talonpoint@us.af.mil](mailto:afsoca3.talonpoint.talonpoint@us.af.mil). If operational requirements dictate use of the survey by Air Mobility Command (AMC) publishers will notify AMC Combat Operations (AMC/A3D) that a new survey is listed in Talon Point. **(T-2)**.

2.3.8. Survey End Users. Mission planners, air planners, aircrew, and support ground personnel may acquire valid surveys and available assessments containing zone status and/or condition from Talon Point prior to mission execution. Assessments are conducted in accordance with Chapters **3, 4, and 5** of this publication or AFI 11-235 for FARP. Valid surveys and assessments for operations may exist elsewhere (e.g., local and/or MAJCOM systems, tactics offices). Certification documentation may be uploaded to acquire specific capability roles within Talon Point (e.g., LZ surveyor, DZ Controller).

## 2.4. Support.

2.4.1. AFSOC Support. Route requests for AFSOC support to conduct Continental United States (CONUS)-based surveys by submitting SOCOM Form 111, *USSOCOM JAAAC Mission Request Sheet*, electronically to AFSOC OC/SPDP Combat Plans Distribution List SIPR address: [AFSOC.OC.SPDP.DL@socom.smil.mil](mailto:AFSOC.OC.SPDP.DL@socom.smil.mil) (primary), or if SIPR is unavailable, to NIPR address: [AFSOC.OC.SPDP.DL@us.af.mil](mailto:AFSOC.OC.SPDP.DL@us.af.mil). Outside Continental United States (OCONUS) surveys are vetted through the respective theater MAJCOM to AFSOC using the Automated Message Handling System NLT 120 days prior to scheduled use. For United States European Command (USEUCOM) requests for Special Operations Forces (SOF) support, contact the 352d Special Operations Wing, RAF Mildenhall, United Kingdom at Defense Switched Network (DSN): 314-238-6353. For United States Pacific Command (USPACOM) requests for SOF support, contact the 353rd Special Operations Group, Kadena Air Base, Japan DSN 315-634-8545. To directly request ANG Special Tactics personnel, coordinate with National Guard Bureau Guardian Angel and Special Tactics Branch (NGB/A3J): [ngb.a2.3.6.a3j.org@us.af.mil](mailto:ngb.a2.3.6.a3j.org@us.af.mil). Additionally, if NGB/A3J approves to support the survey request, submit a SOCOM Form 111 to AFSOC stating in the remarks that the task has been fulfilled by a NGB unit.

2.4.2. AMC Support. Route requests for CONUS Contingency Response Group (CRG) and all Air Mobility Liaison Officers (AMLO) support to AMC Mobility Support Operations and Plans (AMC/A3MO): [AMC.A3MO.Org@us.af.mil](mailto:AMC.A3MO.Org@us.af.mil), DSN: 312-779-4373.

2.4.3. United States Air Forces in Europe, Air Forces Africa (USAFE-AFAFRICA) Support. Route requests for USAFE-AFAFRICA support to conduct DZ/LZ surveys through the 435 CRG ([435crg.a3@us.af.mil](mailto:435crg.a3@us.af.mil)), DSN: 314-480-8619 NLT 120 days prior to scheduled use. Adjust contingency request timelines to meet mission requirements. If not available, route DZ/LZ requests to Headquarters Special Operations Command, Europe (SOCEUR) – Current Operations ([eucom.stuttgart.soc-eur.mbx.joc-soceur@mail.mil](mailto:eucom.stuttgart.soc-eur.mbx.joc-soceur@mail.mil)), DSN: 314-430-4341.

2.4.4. United States Indo-Pacific Command (USINDOPACOM) Support. Route requests for USINDOPACOM support to 36 CRG Andersen Air Force Base (AFB), Guam, DSN: 315-362-2268.

## Chapter 3

### DROP ZONE OPERATIONS

**3.1. General.** This chapter outlines the basic criteria, markings, and procedures used in support of airdrops. It describes the responsibilities of the Drop Zone Controller (DZC), the ground unit's Drop Zone Safety Officer (DZSO) if required in addition to the DZC, and the DZ survey process.

3.1.1. Airdrop Direction. Aircrew or ground units can direct airdrops.

3.1.2. Release Point Identification. Aircrew can utilize visual means or self-contained electronic means, or a combination of the two, to identify the release point or launch acceptability region. The ground unit can also utilize visual means or organic electronic means, or a combination of the two, to identify the release point or launch acceptability region.

3.1.3. Release Point Comparison. Regardless of who directs the drop, the aircrew and ground unit should compare release point or launch acceptability region calculations prior to the airdrop.

### 3.2. Responsibility.

3.2.1. Shared Responsibility. The airlift mission commander and ground mission commander share responsibility for ensuring that any DZ being considered meets the requirements (e.g., size, location, acceptable risk level, type airdrop, type airframe) for the operation. For deviations, see [paragraph 1.3](#); for waivers, see [paragraph 1.4](#).

3.2.1.1. Both the airlift mission commander and ground mission commander should conduct a thorough risk assessment during the mission planning cycle to ensure that concerns from either organization can be addressed prior to mission execution.

3.2.1.2. The ground mission commander shall be responsible for DZ establishment, operation, safety, and for the removal, or acceptance of, ground hazards associated with the DZ. **(T-0)**.

3.2.1.3. The ground mission commander is normally responsible for airdrop accuracy when using GMRS or Verbally Initiated Release System release procedures. The Aircraft Commander (AC) shall assume responsibility for airdrop accuracy if the aircrew adjusts the release point. **(T-0)**.

3.2.1.4. The jumpmaster (JM), performing under the authority of the ground mission commander, shall be responsible for airdrop accuracy when using Jumpmaster Directed (JMD) release procedures. **(T-0)**.

3.2.2. Aircrew Directed Airdrop Responsibility. When performing an aircrew directed airdrop, the airlift mission commander is normally responsible for airdrop accuracy and safety of flight. Aircrew will conduct an airdrop damage estimate in accordance with MAJCOM directives. **(T-2)**.

**3.3. DZ Criteria.** DZ selection factors include (but are not limited to) enemy threats, mission requirements, dispersion, risk of unintended airdrop damage, aircraft capabilities, aircrew capabilities, parachutist capabilities, type of parachutes used, type of equipment to be airdropped, and load or personnel recoverability. The DZ surface, to the greatest degree possible, should be relatively flat, smooth terrain with no obstacles, vegetation or significant terrain features. If

obstacles or other potentially hazardous conditions at the time of survey do exist, the surveyor must identify them on the DZ survey. (T-2). Existing obstacles should be briefed to all personnel prior to use. The ground mission commander and/or jumpmaster must brief obstacles not listed on the survey and all hazardous conditions to personnel prior to use. (T-2). All airdrops conducted on DZs that do not meet DAF minimum size requirements must have a DZ size waiver in accordance with [paragraph 1.4](#). (T-1).

**Table 3.1. Standard DZ Size Criteria. (Note 1)**

ALTITUDE (AGL)	WIDTH (Note 2, 3)	LENGTH (Note 4)		
<b>Simulated Airdrop Training Bundles (Note 5)</b>				
	Radius: 300 yards/274 meters or 200 x 200 yards. Altitude of drop may increase size.			
<b>C-130 Container Delivery System (CDS)/Container Release System (CRS)/Container Ramp Loads (CRL)/Low Cost/Low Altitude (LCLA)/Low Cost Aerial Delivery System – Low Velocity (LCADS-LV)/Combat Expendable Platform</b>				
To 600 feet	400 yards/366 meters	Single bundle containers	Double bundle containers	
		1	1-2	400 yards/366 meters
		2	3-4	450 yards/412 meters
		3	5-6	500 yards/457 meters
		4	7-8	550 yards/503 meters
		5-8	9-16	700 yards/640 meters
		9-12	17-24	850 yards/777 meters
Above 600 feet	Add 40 yards/36 meters to width and length for each 100 feet above 600 feet (add 20 yards/18 meters to each side of DZ, 20 yards/18 meters to each end)			
<b>C-17 CDS/LCADS-LV</b>				
To 600 feet	450 yards/412 meters	Single bundle containers	Double bundle containers	
		1	1-2	590 yards/540 meters
		2	3-4	615 yards/562 meters
		3	5-6	665 yards/608 meters
		4-8	7-16	765 yards/700 meters
		9-14	17-28	915 yards/837 meters
		15-20	29-40	1065 yards/974 meters
Above 600 feet	Add 40 yards/36 meters to width and length for each 100 feet above 600 feet (add 20 yards/18 meters to each side of DZ, 20 yards/18 meters to each end).			
<b>High Velocity (HV) CDS (using 12, 22, 26, or 15 foot ring slot parachutes and one, two or three 68-inch parachutes)/LCADS-HV</b>				
To 1000 feet	400 yards/366 meters	400 yards/366 meters		
		Add 50 yards/46 meters to trailing edge for each additional row of containers.		

1001-3000 feet	Add 9 yards /9 meters for each 100 feet above 1000 feet	Add 13 yards/12 meters for each 100 feet above 1000 feet Add 50 yards/46 meters to trailing edge for each additional row of containers.	
Above 3000 feet	Add 50 yards/46 meters to width and 200 yards/183 meters to the length for each 1000 feet above 3000 feet (add 25 yards/23 meters to each side and 100 yards/91 meters to each end for every 1000 feet increase in drop altitude).		
<b>High Speed Low Level Aerial Delivery System (HSSLADS)</b>			
	300 yards/ 274 meters	600 yards/549 meters	
<b>PERSONNEL (Static Line)</b>			
To 1000 feet	600 yards/ 549 meters	1 Parachutist	600 yards/549 meters
		Additional Parachutists	Add 75 yards/69 meters to the trailing edge for each additional parachutist (or to the Point of Impact (PI) for parachutists identified in <b>Note 4d</b> ). May include safety zone if required (see <b>Note 4c</b> ).
Above 1000 feet	Add 30 yards/28 meters to width and length for each 100 feet above 1000 feet (add 15 yards/14 meters to each side of DZ, 15 yards/13 meters to each end).		
<b>COMBINATION DROPS: Equipment followed by personnel (Note 6)</b>			
<b>HEAVY EQUIPMENT</b>			
To 1100 feet	600 yards/ 549 meters	1 Platform	1000 yards/915 meters
		Additional Platforms	Add 400 yards/366 meters (C-130), 500 yards/457 meters (C-17) to the trailing edge for each additional platform
Above 1100 feet	Add 30 yards/28 meters to the width and length for each 100 feet above 1100 feet (add 15 yards/14 meters to each side of DZ, 15 yards/14 meters to each end).		
<b>C-17 DUAL ROW AIRDROP SYSTEM (Notes 7 &amp; 8)</b>			
To 1200 feet	600 yards/ 549 meters	1 Platform	1000 yards/915 meters
		Additional Platforms	Add 400 yards/366 meters to the trailing edge for each additional platform
Above 1200 feet	Add 30 yards/28 meters to the width and length for each 100 feet above 1200 feet (add 15 yards/14 meters to each side of DZ, 15 yards/14 meters to each end).		
<b>C-130H, J/C-17 JPADS GUIDED SYSTEMS (Note 9)</b>			
3500 feet AGL- 25,000 feet MSL	Standard Radius: 328 yards/300 meters		
	JPADS ULW/JPADS 2K-M: Radius: 200 meters JPADS 4K/JPADS 10K: Radius: 300 meters		
<b>Note 1:</b> LTFW, tilt-rotor, and helicopter requirements identified by MAJCOM.			
<b>Note 2:</b> Additional DZ width adjustments. (N/A with Personnel Recovery [PR] / Combat			

Search and Rescue [CSAR] assigned/gained aircraft, AFSOC assigned/gained aircraft, aircraft OPCON to USSOCOM or to a theater special operations command, and for C-130J/C-17 Embedded Global Positioning System [GPS]/Inertial Navigation System [EGI] drops.)

- a. Day visual formations (Non-Station Keeping Equipment [SKE]); increase width by 100 yards/92 meters (50 yards/46 meters on each side) (N/A for C-130J independent run-ins or flying to their own Computed Air Release Point (CARP)).
- b. Night visual single ship; increase width by 100 yards/92 meters (50 yards/46 meters on each side) (N/A for C-130J drops).
- c. Night visual formation (Non-SKE); increase width by 200 yards/184 meters (100 yards/92 meters on each side) (N/A for C-130J independent run-ins or flying to their own CARP).
- d. SKE formation; increase width by 400 yards/366 meters (200 yards/184 meters on each side).
- e. For C-130J and C-130H using radar verified airdrop, width adjustments not required if all aircraft in the formation are flying their own bomb line.

**Note 3:** C-17 DZ width adjustments (more than one may be required):

- a. Day/Night pilot directed formation; increase width by 100 yards/92 meters (50 yards/46 meters on each side).
- b. SKE formation (Heavy Equipment/CDS); increase width by 400 yards/366 meters (200 yards/183 meters on each side).
- c. Personnel formation; minimum DZ basic width using center Points of Impact (PIs) is 1240 yards for 2-ship elements and 1800 yards for 3-ship elements. When using offset PIs, minimum basic width is 1050 yards for 2-ship elements and 1300 yards for 3-ship elements. Drop altitude adjustments from chart still apply.

**Note 4:** Additional Length Adjustments. (N/A with Personnel Recovery [PR] / Combat Search and Rescue [CSAR] assigned/gained aircraft, AFSOC assigned/gained aircraft, aircraft OPCON to USSOCOM or to a theater special operations command, and for C-130J/C-17 Embedded Global Positioning System [GPS]/Inertial Navigation System [EGI] drops.)

- a. Night visual airdrops; increase length by 100 yards/92 meters (50 yards/46 meters on each end).
- b. May utilize a safety zone: A distance established by agreement between the airlift mission commander and the ground mission commander subtracted from the DZ trailing edge to reduce the potential for off-DZ drops. For peacetime personnel airdrops, the safety zone will never be less than 200 yards. (T-0). Do not compute safety zone distances for high altitude low opening or high altitude high opening airdrops.
- c. USSOCOM and AFSPECWAR personnel may compute 75 meters per additional jumper starting from the PI. Example: A 600 yard-long DZ with a center point PI, 5 jumpers may exit.

**Note 5:** Standard Airdrop Training Bundle (SATB) airdrops conducted on military reservations and/or restricted areas can use standard CDS DZ size criteria. During actual instrument meteorological conditions (IMC), follow the standard DZ size criteria for the type of SATB airdrop being conducted. For C-130 night/SKE formations conducted during visual meteorological conditions (VMC), increase DZ radius by 20 yards.

**Note 6:** When multiple aircraft conduct door or ramp bundles during combination drops with personnel during formation airdrops to the same PI, the lead aircraft may require DZ be extended into the axis of approach in the direction of flight from the following aircraft's PI. If required, this extension should be consecutive for each subsequent combination drop aircraft in the same formation. Ensure the extension fits within the survey DZ boundaries.

**Note 7:** 18 feet platforms: Platform placement on the aircraft, as well as the number of platforms actually on board, determines the number of platforms used to calculate the minimum size DZ; add the number of empty positions between the actual platforms/pallets being dropped to the overall number of pallets. **(T-0)**. For example: One platform in position 1L and one platform in position 4R would require calculations based on five platforms.

**Note 8:** 463L or eight feet training platforms: Minimum DZ size is 1600 yards/1463 meters long by 600 yards/549 meters wide for the two or three pallet/platform training configuration.

**Note 9:** A DZ survey is not required to have a comment stating that it is approved for Joint Precision Airdrop System (JPADS). However, if the survey has been reviewed and approved for JPADS use prior to being published on the survey database, a comment can be added to the block 11 remarks of the AF Form 3823 stating approval for JPADS and PI location. Refer to **paragraph 3.3.5** for additional restrictions and requirements.

**Note 10:** Additional guidance for personnel deployments may be found in AFI 10-3503, *Personnel Parachute Program*, TC 18-11 *Special Forces Double-Bag Static Line Operations*, AFMAN 11-420, *Static Line Parachuting Techniques and Training*, and AFMAN 11-231, *Computed Air Release Point Procedures*.

**Table 3.2. Standard Point of Impact Placement. (Notes 1, 2 & 3)**

<b>TYPE DROP</b>	<b>MINIMUM DISTANCE FROM LEADING EDGE OF DZ</b>	
<b>C-130</b>	<b>DAY/NIGHT/IMC</b>	<b>NIGHT VISUAL AIRDROPS</b>
CDS	200 yards/183 meters	250 yards/229 meters
Personnel	300 yards/274 meters	350 yards/320 meters
Equipment	500 yards/457 meters	550 yards/503 meters
<b>C-17</b>	<b>DAY/NIGHT/IMC</b>	<b>NIGHT VISUAL AIRDROPS</b>
CDS/Dual Row Airdrop System	225 yards/206 meters	275 yards/251 meters
Personnel	300 yards/274 meters	350 yards/320 meters
Equipment	500 yards/457 meters	550 yards/503 meters

**Note 1:** For lateral placement, the PI must be located no closer than one-half the width of the minimum size DZ (based upon type of airdrop and airdrop formation) from the nearest side of the DZ. **(T-3)**. Offset PI will be in accordance with **paragraph 3.3.12. (T-3)**.

**Note 2:** The PI may be located anywhere within the surveyed DZ boundaries as long as the minimum required DZ size for that type airdrop and airdrop formation fits within the boundaries and provided the distance from the leading edge and sides is complied with. All participants must be briefed when using this option. **(T-1)**.

**Note 3:** DZC must relay all PI coordinates, if different than surveyed or pre-coordinated, to the aircrew NLT 15 minutes prior to time on/over target (TOT). **(T-3)**. If PI coordinates are not relayed 15 minutes prior, aircrew will advise earliest TOT feasible for new coordinates. **(T-3)**.

3.3.1. Water DZ. Water DZs are normally circular and should meet the minimum size criteria listed in **Table 3.1** and **Figure 3.1** Water DZs may be marked or unmarked. Additional restrictions will be at the discretion of the supported unit using the Water DZ. **(T-2)**. Parachutist flotation requirements are specified in ATP 3-18.11, *Special Forces Military Free-Fall*



*Operations*, TC 18-11, *Special Forces Double-Bag Static Line Operations*, and AFMAN 11-420. Minimum safety boat and swimmer requirements during intentional water drops are specified in AFI 10-3503.

3.3.1.1. DZ water depth will be a minimum of ten feet, and the area must be free of underwater obstructions to that depth. **(T-2)**. The DZ should be free of floating debris, moored craft, protruding boulders, stumps, pilings, or other hazards within 440 yards/400 meters of the DZ center point.

3.3.1.2. The DZ should not be located near swift currents. For personnel drops, the current limits are at the discretion of the JM and should not exceed two knots.

3.3.1.3. Sea state limits are based on the ability of recovery assets to quickly locate and recover jumpers and their equipment. Sea state limits are at the discretion of the JM. **(T-2)**. See [Attachment 2](#) for wind and sea state observation chart.

3.3.2. Tactical DZ. A tactical DZ is a DZ that is approved for use in an abbreviated or expeditious manner primarily intended to support emerging mission requirements during contingencies or exercises. Tactical DZs are normally restricted to exercise or contingency missions supporting resupply and personnel infiltration airdrops (versus proficiency jumps, routine training, etc.). Tactical DZ surveys are processed and approved in an abbreviated manner, do not require an AF Form 3823 to be physically signed, and may be passed electronically and/or verbally. Tactical DZs normally require a physical inspection of the DZ by the ground mission unit and a safety of flight review. However, computer-based mapping tools, imagery analysis, and other standoff tools may be used during exercise or contingency operations when tactical conditions do not permit the ground mission unit to physically occupy the DZ area to collect survey data.

3.3.2.1. Tactical DZ surveys may be required to support highly mobile ground forces. For training operations where tactical DZs are both surveyed and controlled by DZC-certified AFSPECWAR personnel, Group/CC or O-6 equivalent or higher with authority over aviation missions or assets may approve the use of training tactical DZs for the duration of the training operation.

3.3.2.2. The mode of delivery, load dispersal, and air item recoverability and load survivability discussion with the ground mission commander determines the tactical DZ size. **NOTE:** Do not use tactical DZs for routine operations. **(T-1)**. Complete a standard DZ survey for recurring operations not covered in [paragraph 3.3.2](#). **(T-1)**. If a tactical DZ survey is done to meet new run-in axis requirements on an existing survey, then only a safety-of-flight review is required. MAJCOMs may define the minimum information and/or format for a tactical DZ survey. Recommended minimum information, (mission and tactical considerations may deviate) is located in [figure A4.1](#) to include blocks 1A, 2A, 2B, 4D, 6A-B or C, 7, 9, and 11 as applicable.

3.3.3. Military Free Fall (MFF) DZ (including operations utilizing MFF systems in a Double Bag Static Line (DBSL) configuration). The JM will determine the minimum size DZ based on the number of personnel to be dropped, jumper proficiency, parachute system being used, and the prevailing winds. **(T-3)**. For MFF training operations a minimum DZ size of 55 yards/50 meters by 110 yards/100 meters (rectangular) or 55 yards/50 meters radius (circular) is recommended. See [paragraph 3.16.1.1](#) for parachute demonstration DZ.



3.3.4. Unmarked land DZ. Unmarked land DZs are not authenticated with any type of visual or electronic marking. Unmarked DZs are normally used for contingency operations and austere polar environments and may or may not have a DZ party present. All participants involved in an unmarked drop operation will be thoroughly briefed. **(T-3)**.

3.3.4.1. Aircrew/Aircraft/Flying Unit Restrictions. 109<sup>th</sup> Air Wing (AW) aircraft, PR/CSAR assigned or gained aircraft, AFSOC assigned or gained aircraft, aircraft OPCON to USSOCOM or to a theater special operation command may utilize unmarked land DZs for training, exercises, and operations without a waiver. All other aircrew/flying units require a waiver in accordance with **paragraph 1.4** prior to conducting unmarked land DZ airdrops during training and exercises. During contingency operations, the OPCON MAJCOM/A3, Air Component Commander, or designated authority will evaluate the risks associated with DZ verification and airdrop accuracy prior to approving non-special operations forces to conduct unmarked land DZ operations.

3.3.4.2. Airdrop Personnel/Ground Personnel Restrictions. For training and exercise missions, only DZC-certified AFSPECWAR personnel; survival, evasion, resistance, and escape (SERE) specialists; USSOCOM assigned forces; and 109<sup>th</sup> AW personnel are authorized to control unmarked land DZs. For training and exercise missions, a DZC party must be on site for safety. **(T-2)**. **Exception:** Austere polar DZs do not require a DZC party for training or exercises. All other DZC-certified personnel will require a waiver for unmarked training and exercise missions. **(T-2)**. During contingency operations, the ground forces commander should evaluate the risks associated with airdrop accuracy and injury or damage to personnel and equipment prior to approving unmarked DZ operations with MAJCOM/A3, Air Component Commander, or designated authority concurrence. During training, drops conducted to austere polar DZs are typically unmanned and unmarked and do not require a DZC or two-way communications drop clearance. Crews will visually clear the DZ to the maximum extent possible. **(T-2)**.

3.3.5. Joint Precision Airdrop System/Improved Container Delivery System DZ. JPADS refers to both GPS guided systems and traditional ballistic airdrop loads utilizing the consolidated airdrop tool or approved programs for more precisely computed release points. Prior to airdrop operations, complete and approve JPADS and Improved Container Release System (I-CDS) DZ surveys independent of the Airdrop Damage Estimate (ADE). For JPADS and I-CDS training drops, file a Notice to Airmen (NOTAM) for all high-altitude airdrops. **(T-2)**. The NOTAM airspace must be no smaller than the diameter of the largest failure footprint ellipse for the highest drop altitude. **(T-2)**. The minimum altitude for training is 3,500 feet above ground level (AGL).

3.3.5.1. JPADS (guided systems) DZs are primarily circular, with the PI at the center. If a circular DZ survey does not exist, rectangular DZs may be used if applicable circular DZ requirements are met within the boundaries of the rectangular DZ. In this case, for the PI use the centerpoint of the rectangular DZ (or as close as possible). When using a centerpoint of a rectangular DZ, be sure to use the actual elevation. Many DZ surveys do not list the centerpoint elevation, they only list elevation for CDS PI, Heavy Equipment PI, Personnel PI, and highest. Using one of those four elevations for the JPADS center point is unacceptable. Use alternate means to acquire the true DZ centerpoint elevation. It is critical to both plan the mission and program the JPADS Autonomous Guidance Unit with the correct elevation.

- 3.3.5.1.1. During training operations, limit GPS guided system drops to DZs located in restricted areas and airspace to include all space between load exit and the planned landing PI. The aircrew or flying unit must complete a thorough ADE. **(T-2)**. Waivers to the airspace criteria are in accordance with [paragraph 1.4](#).
- 3.3.5.1.2. During contingency operations, the ground mission commander will determine the JPADS (guided systems) minimum DZ size with the advisement of the airlift mission commander, using [Table 3.1](#) as a starting reference. **(T-0)**. Locate the JPADS DZ and Launch Acceptability Region (LAR) within a restricted operating zone. Select the JPADS DZs to guarantee that all bundles land within the confines of the restricted operation zone to the maximum extent possible. **(T-2)**.
- 3.3.5.2. I-CDS DZs are typically normal rectangular CDS and/or High Velocity Container Delivery System (HVCDS) DZs in accordance with [Table 3.1](#) However, unlike traditional CDS, I-CDS provides the ability to “target” a specific bundle for PI impact. For circular DZs, it may be appropriate to target the middle bundle in a stick. For all I-CDS airdrops, there is no minimum DZ requirement, but crews will ensure that the ADE, including the failed chute ellipse, fits within the surveyed DZ boundaries. **(T-2)**.
- 3.3.5.3. In accordance with MAJCOM/A3 or Air Component Commander guidance, aircrew must complete an ADE prior to each JPADS (guided systems) and I-CDS airdrop operation. **(T-2)**. Complete a new ADE when time or airdrop conditions have changed to create a likelihood of inaccuracy in the previously accomplished ADE. **(T-2)**. Advise the ground mission commander on ADE determinations. **(T-2)**. For contingency operations, an agency designated by the Joint Forces Commander may be the approving authority for risk to the areas surrounding the DZ.
- 3.3.6. Random Approach DZ. All approved rectangular DZs are random approach DZs unless block 11, remarks, of the AF Form 3823 specifically restricts it, or for safety reasons; random approaches may be used if the airdrop profile requirements can be met within the existing confines of the DZ to permit multiple run-in headings to an alternate PI established during mission coordination. Refer to [Table 3.2](#) and [Figure 3.1](#) Use of a DZ for random approaches does not require a separate survey, but a safety of flight review must be conducted prior to use. **(T-2)**. Surveyors and reviewers are encouraged to include random approach axis data, applicable altitude parameters, and alternate PI locations on the published survey to enhance flexibility for recurring operations.
- 3.3.7. Circular DZ. The PI of a circular DZ is normally at the DZ center to allow for multiple run-in headings. For specific missions, the PI location may be adjusted to allow for sequential HE or mass CDS, on circular DZs. Refer to [Figure 3.1](#), option 2 for PI placement. Utilizing a PI not at the center of the circular DZ may limit the run-in heading to only one direction. When dropping mass CDS to a center point PI, aircrews may target the sticks middle bundle to the center point. The minimum DZ dimensions for the type and number of loads being dropped must completely fit into the surveyed circular DZs. **(T-2)**. For both types of PI placement, use [Figure 3.1](#) to determine the number of jumpers per pass.

Figure 3.1. Circular DZ Computation.

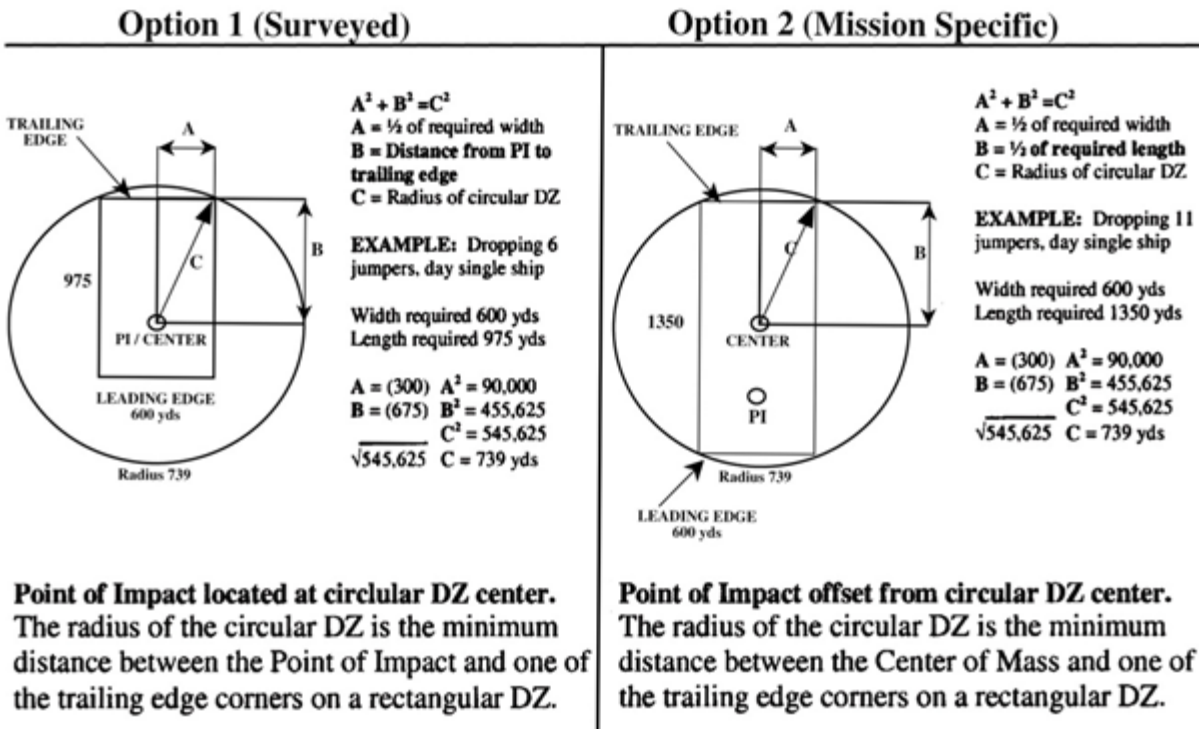

3.3.8. Area DZ. Area DZs are not applicable to C-17 and C-130 operations except Special Operations Low Level II qualified crews and AFSOC aircrews. An area DZ consists of a start point (point A), an endpoint (point B), and a pre-arranged flight path (line-of-flight) over a series of acceptable drop sites between these points, as shown in Figure 3.2 The distance between points A and B generally should not exceed 15 Nautical Miles (NM) and changes in ground elevation within 1/2 NM of centerline should not exceed 300 feet. The reception committee may receive the drop at any location between point A and point B within 1/2 NM of centerline. Perform the airdrop once the pre-briefed signal or electronic Navigational Aids (NAVAID) has been identified and located. (T-3).

Figure 3.2. Area DZ.

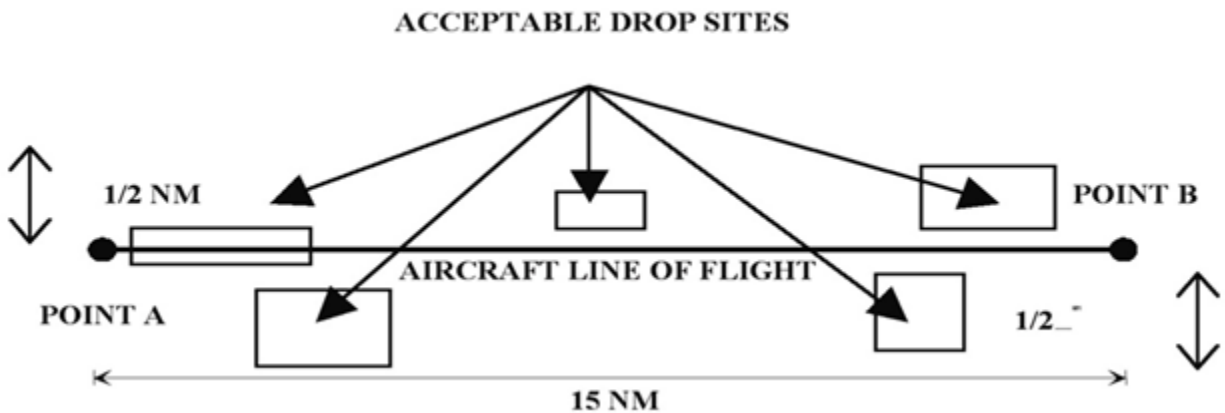

3.3.9. Dropsondes. Dropsondes do not have a minimum DZ size and are deliberately and manually released from the aircraft to gather meteorological data for follow-on operations. Sonde drops are required prior to certain I-CDS drops. When dropping JPADS, dropsondes are not required. However, when dropping near the edge of the Launch Acceptability Region (LAR) or in strong and/or variable wind conditions, dropping a dropsonde is strongly recommended to improve the drop solution and reduce risk. Drop clearance will be required for all sonde releases. **(T-2)**. **Exception:** USAF Precision Jumpmaster moving target operations. **(T-2)**.

3.3.9.1. During training and exercise operations, aircrews and jumpmasters ensure that the sonde will land on the DZ or within a restricted area to avoid airdrop damage and to aid recovery of the sonde. **(T-2)**. Aircrews and jumpmasters will ensure landing location coordinate reporting and recoverability are in accordance with MAJCOM guidance. **(T-2)**.

3.3.9.2. During contingency operations, dropsondes may be released anywhere in the vicinity of the objective area and do not have to land on the DZ. Ground mission commander's and airlift mission commander's must take appropriate measures to ensure dropsondes will not exceed ground mission commanders acceptable level of risk for unintended injury or damage. **(T-0)**.

3.3.10. Random Point of Impact (RPI). When mission requirements dictate, RPI placement within the surveyed DZ may be used in lieu of the surveyed PI. The DZ size, responsibility, and accuracy requirements still apply when an RPI is used. Pre-coordination normally includes the air unit commander, ground unit commander, jumpmaster, and DZC/DZSO concurrence on RPI location and intent for use. Requests will be made at least 24 hours prior to time on target (TOT) for training operations. **(T-2)**. Exercise and contingency operations do not require requests made 24 hours prior; however, DZC, DZSO, and/or ground force commander must establish RPI location concurrence and positive communications with airlift mission commander and/or jumpmaster NLT 15 minutes prior to airdrop in accordance with **Table 3.2** **(T-3)**. **NOTE:** Relay all PI coordinates, if different than those surveyed or pre-coordinated, to the aircrew NLT 15 minutes prior to the TOT. **(T-3)**. If PI coordinates are not relayed 15 minutes prior, aircrew will advise DZ personnel of earliest feasible TOT for new coordinates. **(T-3)**.

3.3.11. Multiple Points of Impact (MPI). MPI airdrops are authorized if all personnel involved have been properly briefed. MPI airdrops are an aerial delivery method that allows for the calculated dispersal, both laterally and longitudinally, of airdropped loads to predetermined locations on a DZ. The DZ must meet the minimum size for each PI according to the requirements listed in **Table 3.1** and **Table 3.2** Additionally, provide the precise location of each PI to aircrews. **(T-1)**.

3.3.12. Offset PIs. Compute offset PIs from the surveyed PI. Formation personnel airdrops may require offset PIs. Use 250 yards left and/or right offset for 3-ship operations, and use a 125 yards left and/or right offset for 2-ship operations unless pre-coordinated. **(T-3)**. Increase the DZ width accordingly to meet the distance criteria from the DZ edge to the PI. **(T-3)**. AFSOC Special Operations Low Level II offset PIs will be 150 yards left and/or right of centerline and DZ width requirements will be met unless pre-coordinated. **(T-3)**. DZs with offset PIs will have a minimum width of 900 yards. **(T-3)**. Offset PIs are authorized but centerline PIs are required to be on the DZ survey. **(T-3)**.

**3.4. Instrument Meteorological Condition Airdrops.** USAF or USSF unilateral training and exercise airdrops of actual personnel or equipment require a minimum of a 300 feet AGL ceiling and one-half mile visibility at the DZ. **(T-1).** During contingency operations, ceiling and visibility minimums are at the discretion of the ground mission commander. For joint training and exercises, DAF personnel are authorized to use Army ceiling and visibility minimums. When the ceiling is less than 600 feet AGL, the DZC/DZSO will remove all personnel from the DZ NLT 5 minutes prior to the scheduled airdrop TOT and ensure they remain off the DZ until completion of the airdrop. **(T-1).**

**3.5. Hazards, Obstacles, and Restrictions.** Hazards may be present on or in the vicinity of any type of DZ. Identify these hazards to all personnel and apply the appropriate risk management to mitigate potential injury or equipment damage. Identify DZ hazards to the greatest extent possible. **(T-2).**

3.5.1. Terrain Hazards. Terrain hazards are naturally occurring features on the DZ surface such as steep slopes, culverts, ditches, berms, boulders, and rock outcrops which create a landing hazard to personnel or equipment. Locate the designated PI away from these hazards to the greatest degree possible and mark hazards at the discretion of the DZC and ground mission commander. Rapidly rising terrain and/or mountainous area, (as defined by International Civil Aviation Organization (ICAO)), within 10 NM of the DZ center point will be documented on the DZ survey. **(T-2).** 10 NM may not be sufficient for high altitude operations. A mountainous area is an area of changing terrain profile where the changes of terrain elevation exceed 900 meters (3000 feet) within a distance of 18.5 km (10.0 NM).

3.5.2. Airspace Hazards. The existence of instrument flight rules, military training routes, visual flight rules (VFR), training routes, and slow routes and airway (Victor, Jet, or ICAO equivalent) may be hazardous to aircraft on the run-in or escape course. Document all military training routes, VFR routes, and slow routes within a 10 NM radius of the DZ center point, on block 11, remarks of AF Form 3823. **(T-2).**

3.5.3. Vegetation Hazards. Vegetation hazards are large trees greater than 35 feet, or other plants likely to cause injury or damage to personnel or equipment. Small trees, shrubs, and other plants which will crush or break upon impact from a jumper or equipment load are not considered vegetation hazards. Locate the designated PI away from these hazards to the greatest degree possible. **(T-3).** DZCs are not required to mark vegetation hazards.

3.5.4. Manmade Hazards. Manmade hazards include structures, debris, and operational support equipment or vehicles on the DZ. Locate the designated PI away from fixed hazards when possible and minimize supporting equipment and personnel inside the surveyed boundaries of the DZ during airdrop operations. If required on the DZ, the location of support equipment and vehicles may be briefed prior to the operation, and they should be visibly marked during night operations to assist in jumper identification and avoidance.

3.5.5. Obstacles. Antennas, towers, and aerial cables located outside the DZ can pose a risk to both the aircrew and the airdropped equipment or personnel. Document obstacles within 10NM that are 300 feet AGL or higher on block 11, remarks, of AF Form 3823. **(T-2).** For OCONUS areas where map data is not available, include any visual observation and note that map data was not available. If available, reference obstruction change file.

3.5.6. Aerial Power Line Restrictions. Power lines present a significant hazard to jumpers. Personnel can sustain life threatening injuries from electric shock and/or falls from a collapsed canopy. All restrictions apply to aerial power lines operating at 50 kilovolts or greater. Power lines will be documented on both block 11, remarks, and block 10, DZ diagram, of AF Form 3823. **(T-3)**.

3.5.6.1. If power lines are within 1094 yards/1,000 meters of any boundary (or PI for MFF-only DZs), coordinate with the power company to shut off power NLT 15 minutes prior to TOT.

3.5.6.2. If power cannot be shut off, brief all personnel. **(T-3)**. Document power lines on the DZ survey, to include status, shut off coordination procedures, and other relevant factors. **(T-3)**. The AC, aircrew, and JM must conduct a risk assessment of the mission. **(T-3)**. Include as a minimum with; type jump, jumper experience, aircrew experience, ceiling, and surface/altitude wind limits required to approve, suspend, or cancel the operation. To further minimize risks, consider altering the mission profile to raise and/or lower drop altitudes, change DZ run-in and/or escape headings, or remove inexperienced jumpers from the stick.

3.5.7. Water Hazards. A water hazard is any body of water that has a depth of four feet or more with an area greater than 40 feet in length and/or 40 feet in width.

3.5.7.1. Identify water hazards on both block 11, remarks, and block 10, DZ diagram, of AF Form 3823, and brief to operation participants when a hazard is within 1,000 meters/1094 yards of the DZ boundary for static line operations and 1,000 meters/1094 yards of the PI for MFF/DBSL operations. **(T-2)**.

3.5.7.2. Conduct planning and coordination to ensure parachutist flotation, safety boat, and swimmer requirements can be met for all intentional water parachutist operations and, as required, static line and/or DBSL land operations with identified DZ water hazards, in accordance with AFI 10-3503, ATP 3-18.11, TC 18-11, and AFMAN 11-420. **(T-2)**. Additionally, conduct planning and coordination to ensure parachutist flotation requirements can be met whenever the planned flight path is over open bodies of water large enough to be unavoidable with a maneuverable parachute for one third or more of the distance under canopy, and when an open body of water is within 1,000 meters of the planned impact point. **(T-2)**.

**3.6. Airdrop Winds**. DZ wind information is critical to airdrop accuracy and aircrews use it to compute the adjusted release point. It is imperative the aircrew receives accurate and timely wind data. This includes not only surface wind and the computed mean effective wind, but also any unusual observations. Examples are wind shear or local phenomena that could affect wind direction, speed, or restrictions to visibility.

3.6.1. Surface Wind. The surface wind at the DZ is normally measured using an anemometer or other calibrated wind-measuring device. Report wind direction in magnetic degrees and wind speed in knots. The direction reported is the direction the wind is coming from. Measure and report surface wind from the PI when DZ terrain and/or vegetation affect accurate wind readings. Reference [Table 3.3](#) and [Table 3.4](#) for a list of surface wind speed limitations. Use [Attachment 2](#), [Table A2.2](#), Summary of Wind Observing Standards, to determine and report



wind data for assault zone operations in accordance with the wind chapter of AFMAN 15-111, *Surface Weather Observations*.

**Table 3.3. Surface Wind Limits for CDS/Equipment Airdrops.**

TYPE CDS/EQUIPMENT DROP	SURFACE WIND LIMITS (KNOTS)
USAF Equipment	17
USAF CDS and High Altitude Airdrop Resupply System II using LCADS-LV or G-12 parachutes	13
USAF CDS using G-13 parachutes	20
HV CDS, HSLADS, or LCADS-HV	No Restriction
LCLA	Per MAJCOM directive (e.g., Flight Crew Information File (FCIF) or guidance supplement)
CDS/Equipment using JPADS	17
SATB	25
Rescue Air-deployable Maritime Boat/Advanced Rescue Craft /Combat Expendable Platform Bundles	25
Non-USAF Equipment	Discretion of supported force DZSO

**Table 3.4. Surface Wind Limits for USAF Personnel Airdrops.**

TYPE PERSONNEL DROP (See Notes)	SURFACE WIND LIMITS (KNOTS)
USAF Static line Land/Intentional Tree	13/17
USAF Static Line Water	25
USAF MFF/DBSL Land/Intentional Tree	18/22
USAF MFF/DBSL Water	25
USAF Tandem	18
Non-USAF Personnel	In accordance with supported unit DZSO
<b>Notes:</b>	
1. During operational missions and/or contingencies, the ground mission commander and/or team leader will coordinate wind restrictions with the airlift mission commander or AC based on operational requirements. <b>(T-0)</b> .	
2. Airdrop operations using ram air parachute system which have the capability to be deployed in a MFF or static line operating profile (e.g., Special Operations Vector III, MC-5, etc.) may use MFF surface wind limitations for all parachute deployment profiles.	

3.6.2. Mean Effective Wind (MEW). The MEW is a theoretical wind of constant speed and direction that extends from the ground to a designated altitude. When required, the DZC

determines the MEW by timing the ascension of a helium-filled balloon to a pre-determined altitude and measuring the angle of drift. The MEW is an indicator of the drift line and distance an airdropped object can be expected to travel. **Paragraph A10.1** has the procedure used to conduct and report MEW readings. **Table A10.1** is used to determine average wind speed from the surface to various drop altitudes.

3.6.3. Altitude Winds. There are no altitude wind restrictions for fixed wing airdrops. Refer to the appropriate MDS-specific aircraft flight manual, AFI or AFMAN, for altitude wind restrictions for rotary wing aircraft. If surface winds are not available, altitude winds may influence the JM's decision to drop personnel.

**3.7. DZ Markings.** A marked DZ is a DZ that has a PI or release point marked with a pre-coordinated visual or electronic signal. Any type of lighting or visual marking system is acceptable if all participating units are briefed and concur. Electronic NAVAID may be used for either day or night operations and placed as directed by mission requirements. **NOTE:** Ground parties and aircrews must coordinate and brief NO-DROP markings for all DZs. **(T-2).**

3.7.1. Standard DZ Markings. **Exception:** Not required with PR/CSAR assigned and/or gained aircraft or AFSOC assigned and/or gained aircraft OPCON to USSOCOM, or a theater special operations command.

3.7.1.1. During day operations, mark the PI with a raised angle marker and/or block letter. If authentication is required, use a block letter instead of the raised angle marker. **(T-3).** Authorized letters for PI markings are J, C, A, R, and S. The block letters H and O are authorized for circular DZs. Align the block letters with the surveyed DZ axis or with the aircraft line-of-flight, if different from the survey. The minimum size for block letters will be 35 feet by 35 feet (11 meters by 11 meters) and consist of at least nine marker panels. **(T-2).** Refer to **Figure 3.3**.

3.7.1.2. During night operations, mark the PI with a block letter. The apex of the block letter will be located on the PI. **(T-3).** The minimum size for block letters is 35 feet by 35 feet (11 meters by 11 meters) and consists of at least nine white lights, with a recommended minimum output rating of 15 candelas. When using flanker lights, DZC ensures they will be white and located 250 meters/274 yards left and right abeam the PI, unless precluded by obstacles or obstructions. **(T-3).** If using a distance other than 250 meters/274 yards, the DZC will brief the aircrew. **(T-3).** Use a trailing edge beacon during personnel airdrops. When used, DZC is responsible to ensure the trailing edge beacon is placed along the surveyed DZ centerline 1,000 meters/1094 yards from the PI, or at the DZ trailing edge, whichever is closer to the PI. **(T-3).** During pre-mission coordination for personnel drops, aircrews will identify to the DZC their trailing edge beacon requirements. **(T-3).** For all airdrops, the DZC coordinates and briefs the DZ identification to the ground party and aircrews. **(T-3).** Refer to **Figure 3.3**.

3.7.1.3. Infrared Lighting Systems. When mission requirements dictate and aircrews are trained, equipped, and qualified, infrared lights may be substituted for overt lights using the DZ marking patterns specified in **paragraph 3.7.1**.



Figure 3.3. Standard DZ Markings.

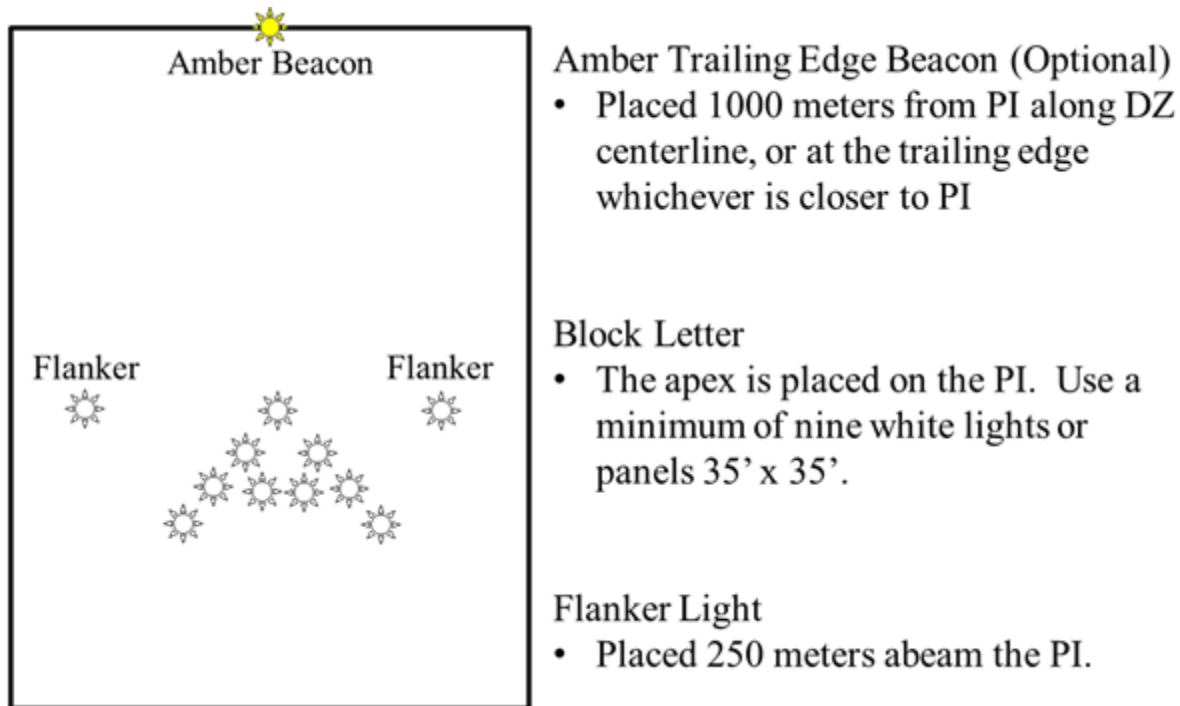

3.7.2. Non-Standard DZ Markings. The situation may dictate the use of nonstandard DZ markings. When using nonstandard markings or identification procedures, all aircrew, jumpers, and DZC, (DZSO/Drop Zone Support Team Leader (DZSTL) when present), involved in a drop operation will be thoroughly briefed. **(T-2)**.

3.7.2.1. For MFF DZs, the two DZ marking systems commonly used for MFF operations are the wind arrow and the green-to-red system. Refer to [Figure 3.4](#).

3.7.2.1.1. The wind arrow is formed by placing visual markers on the ground in the shape of an arrowhead. Align the arrow pointing into the wind. Place the arrow tip marker on the desired impact point. Jumpers fly their approach to land facing the direction of the arrow.

3.7.2.1.2. The green-to-red system consists of one red light or red panel and one green light or green panel. Place the red light/panel on the desired impact point and place the green light/panel between 15 and 50 meters downwind. Jumpers will be briefed on the actual separation of lights/panels. Jumpers will fly their approach to landing from green light/panel to red light/panel. **(T-2)**.

Figure 3.4. MFF DZ Markings.

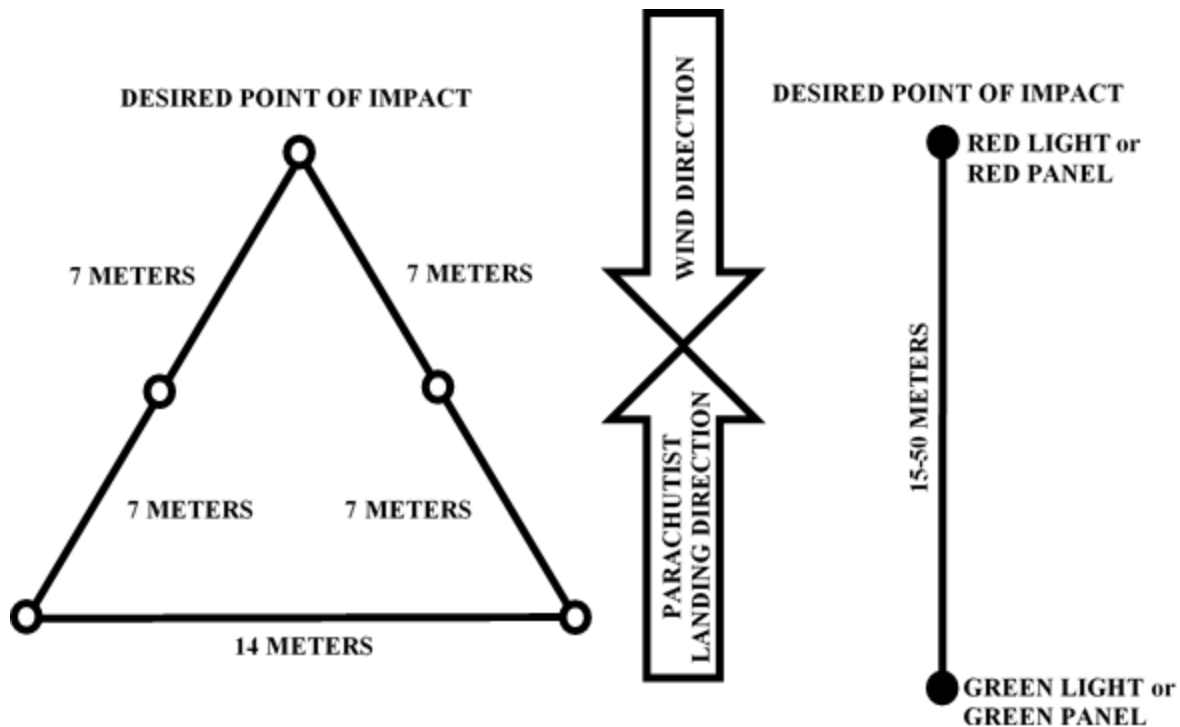

3.7.2.2. Marked water DZs will have mutually agreed upon markings (visual or electronic). (T-2). Select markings that do not mimic local maritime navigational aids (buoys, channel markers, etc.). (T-3). Unmarked water DZ will have predetermined PIs. (T-3). Include the coordinates of the PI in any applicable aircrew, DZC, and JM briefings. (T-3). GMRS, Verbally Initiated Release System, CARP, or JMD (including moving target) procedures may be used on marked water DZs. For GMRS, the position of the recovery or safety boat usually marks the intended release point. For water JMD drops, use moving target procedures. Refer to [paragraph A10.2](#) Other options may be used to mark the DZ; these markings will be pre-briefed. (T-3).

3.7.2.3. Single-Marked Multiple Points of Impact (MPI) procedures are authorized for heavy equipment and/or container delivery system (CDS) airdrops where only the first PI in a series of MPI is marked and all personnel involved have been properly briefed. Single-marked MPI are restricted to the surveyed DZ axis (no lateral displacement) and to a maximum of 1500 yards between the first marked PI and the last unmarked PI. The DZ must meet the minimum size requirements for each PI and the precise location of each PI must be provided to aircrews. (T-1). Refer to [Table 3.1](#) and [Table 3.2](#) for restrictions.

3.7.2.4. JMD airdrop with moving target procedures is used to calculate the jumper release point so a parachutist can land in the close vicinity of a moving target. This technique is designed primarily to allow forces to join a waterborne craft, equipment item, or person in the water that cannot or is not maintaining a constant position. The water dropsonde is approved for moving target procedures. Follow detailed moving target procedures and moving target pattern instruction in [paragraph A10.2](#) and [Figure A10.1](#).

**3.8. Airdrop Communications.** To the maximum extent possible, plan airdrop operations with minimum radio transmissions. In general, all missions are flown as planned with additional radio calls made “by exception” only. Authenticate as required. Detailed mission planning and pre-briefed operating procedures can eliminate many flight-following and information only transmissions. Limit radio contact with the drop aircraft to drop clearance, safety of flight requirements, or issues affecting airborne force employment. This includes air traffic control (ATC) directions, range clearance, unsafe surface conditions or mission changes. DZ winds or other information may be broadcast in the blind at a coordinated time prior to the scheduled TOT.

3.8.1. Airdrop Clearance. Positive radio communication of drop clearance is standard, but not required if mission clearance is corroborated by the appropriate visual or electronic markings. Airdrop operations conducted without radio communications will be thoroughly coordinated prior to mission employment. **(T-2).**

3.8.2. IMC Airdrop Clearance. Training airdrops (both unilateral and joint) conducted during IMC or to an unmarked DZ require the DZC to relay drop clearance (i.e., “Cleared to Drop”), to the aircraft by way of radio communications or other pre-briefed method. Drop clearance is usually accomplished a minimum of two minutes prior to the scheduled TOT.

3.8.3. Operational Airdrop Clearance. Mission approval is considered drop clearance for operational missions when no reception party is present on the DZ.

3.8.4. No-Drop Signals. Indicate a “NO-DROP” condition, DZ closure, or temporary DZ closure in one of the following ways with: authenticated radio transmission, red smoke, red flares, red lights, scrambled panels, or another pre-planned signal. **(T-2).** **NOTE:** During night vision goggle (NVG) operations, colored flares may still be used, but due to the delay in aircrew recognition of color, star clusters or other obvious signals are recommended.

3.8.4.1. During IMC operations, an authenticated radio transmission or the absence of pre-briefed electronic devices will indicate a “NO-DROP” condition. **(T-2).**

3.8.4.2. Use standard no-drop signals to communicate temporary closing of a DZ or postponement of an airdrop. Aircrew should follow up with a radio call to the appropriate command and control (C2) facility as the situation dictates.

3.8.5. Radio Communications. When using radio communications, the following procedures apply:

3.8.5.1. Transmit “NO-DROP” advisories early enough to allow time for authentication; specifically, not later than one minute prior to actual TOT, unless an emergency arises.

3.8.5.2. If last minute conditions preclude a safe drop and time for proper authentication is not available, the DZC will immediately and repeatedly transmit cancellation of drop clearance, “NO-DROP, NO-DROP, NO-DROP.” **(T-3).**

3.8.6. Authorized Relays. Only qualified, certified and current DZ personnel or personnel in DZC training will operate DZ communication equipment. **(T-2).**

3.8.6.1. Relay operational information to the aircraft as requested when abnormal conditions necessitate such requests. DZCs should not be required to handle such messages on a regular basis.

3.8.6.2. If necessary, inform the aircraft of the source of any messages being relayed (DZSO, DZC, ground forces commander, etc.).

3.8.6.3. Transmitting the reason for an aircrew initiated “NO-DROP” is not normally required. However, if time permits, the aircrew should pass the information to the DZC. For a ground initiated “NO-DROP” (if time and security requirements permit), the DZC should inform the aircrew of the reason and should coordinate any further action.

3.8.6.4. During airborne operations, the ground forces commander may need to determine the number of personnel who did not jump to properly account for all personnel. When applicable, request the number of “alibi jumpers” from the aircrew. When requested by the DZC/DZSO/DZSTL, if the tactical situation permits, the DZC should obtain the total number of jumpers remaining on board from the aircrew. This should not be accomplished until after the last aircraft over-flies the DZ, and at no time if it compromises safety or conflicts with aircrew or DZC duties. Should such a conflict occur, delay or cancel transmissions accordingly. During MFF/DBSL operations, if time and flight duty requirements permit, the aircrew should pass “jumpers away” and total number of personnel and chutes.

**3.9. Control Point Location.** The DZC establishes the control point taking into account pertinent factors such as an unobstructed line of sight, winds, positive control of the DZ, surrounding airspace, and security requirements. DZC must consider safety factors when choosing a control point location. **(T-3).**

3.9.1. Control Point Safety Location. During actual IMC or HVCDS, the DZC will locate the control point off the DZ. **(T-3).** The control point for multi-ship heavy equipment and all CDS equipment airdrops will be offset to the left or right of DZ run-in heading a minimum of 300 yards for heavy equipment and 200 yards for CDS from the intended PI. **(T-3).**

3.9.2. Control Point Safety Location in Contingency Operations. Threats during contingency operations may require placement of the control point in a location not in compliance with [paragraph 3.9.1](#) Carefully evaluate the threat against the risk of personal injury due to airdropped equipment. Do not use locations not in compliance with [paragraph 3.9.1](#) for a given DZ any longer than tactically necessary. The DZC will move back to the standard location when the threat is no longer a factor. **(T-0).**

**3.10. En Route and Terminal Navigational Aids.** A variety of electronic NAVAIDS and beacons are available to support DZ operations. NAVAIDS are utilized at the discretion of the airlift mission commander. NAVAID use, to include beacons, will be pre-briefed and pre-coordinated to ensure the proper device is established with the correct setting and at the proper location. **(T-2).** NAVAID use, to include beacons, will follow applicable technical orders and tactics, techniques, and procedures. **(T-2).**

**3.11. GMRS.** The DZC can mark a point on the ground with a visual signal to designate the CARP to the aircrew when controlling an airdrop. This signal may be a four marker “L”, six marker “T”, or seven marker “H” and is placed abeam, and 100 meters/110 yards left of the desired release point as depicted in [Figure 3.5](#) Execute the drop when the aircraft is directly abeam, and 100 meters/110 yards right, of this marker on the pre-briefed inbound heading. A pre-briefed code signal or beacon may be collocated with the markers to aid in DZ identification. Follow GMRS;

marking considerations, determining PI location, and marking placement techniques in paragraphs [A10.3-A10.5](#) respectively.

**Figure 3.5. Ground Marked Release System Day and Night Markings.**

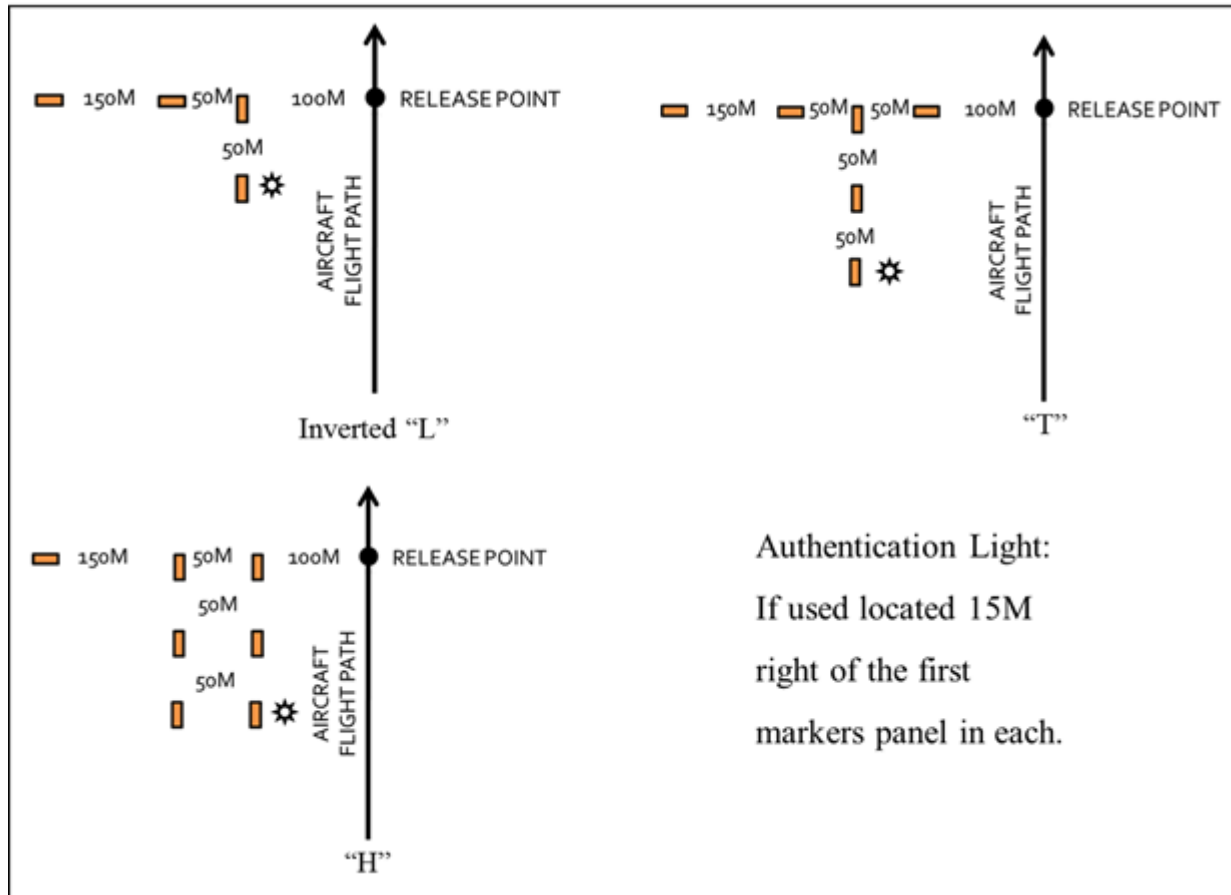

**3.12. Verbally Initiated Release System.** This procedure may be used when normal drop procedures are not tactically feasible. The ground party determines the desired release point, gives verbal steering guidance to the pilot to align the aircraft over that point, and then initiates the release. Instructions transmitted to the aircraft must be concise and are based on the aircraft flight path/heading. (**T-2**).

3.12.1. Transmit "Turn Left" or "Turn Right" to align aircraft on desired inbound heading.

3.12.2. Transmit "Stop Turn" after alignment instructions when aircraft is on course.

3.12.3. Transmit "Standby" to the aircraft approximately five seconds prior to the release point.

3.12.4. Transmit "Execute, Execute, Execute" when the aircraft reaches the release point. Upon hearing the first "Execute", the navigator, combat systems officer or non-flying pilot calls "Green Light."

**3.13. DZ Personnel.** Pending specific eligibility and restriction criteria below, the following individuals, when trained, certified and current in accordance with [paragraph 3.13.4](#), may perform DZC responsibilities listed in [paragraph 3.13.5](#) See specific MAJCOM and/or Service

guidance for additional DZC eligibility and restriction criteria. **NOTE:** Authorized personnel, other than current and previously certified Combat Control Team personnel (CCT), Special Tactics Officers (STO), and qualified, certified, and current Air Mobility Liaison Officers (AMLO), shall be restricted to formation airdrops of four or fewer aircraft unless on a military range with active range control providing ATC services. **(T-2).**

3.13.1. USAF Personnel (Regular AF, ANG and AFR). AF members (other than CCT/STO, AMLOs, DoD civilians or contractors functioning as DZCs) are restricted to a 12-hour duty day. The Group/CC or O-6 equivalent may waive the duty day limitation up to 16 hours.

3.13.1.1. CCT/STO. The DZC will be an E-4 or above with a 5-skill level or higher, certified by the unit commander. **(T-3).** CCT/STO are authorized to control all airdrops for any U.S. or allied military force. See AFSOC guidance for duty day limitations or extensions. Current and previously certified CCT/STO that are DoD civilians and contractors may perform all DZC functions provided their statement of work requires those duties, they are certified by the current unit commander, and meet DZC continuation training in accordance with [paragraph 3.13.4](#). **NOTE:** ANG/AFR Dual Status Technicians may perform these duties in a technician status.

3.13.1.2. AMLOs. AMLOs are authorized to assume DZC responsibilities for any U.S., allied, or coalition military force, in accordance with AFMAN 13-106, *Air Mobility Liaison Officers*. Scheduling restrictions and duty day restrictions for AMLOs are defined in accordance with AFMAN 13-106.

3.13.1.3. AFSPECWAR personnel, SERE Specialists and AFPECWAR Combat Mission Support may perform DZC duties during training missions, exercises and contingency operations. **NOTE:** ANG/AFR Dual Status Technicians may perform these duties in a technician status.

3.13.1.4. USAF Contingency Response (CR) Forces and Air Advisors (RegAF, ANG and AFR). Personnel currently assigned to a Contingency Response Force and Air Advisor units may perform DZC worldwide involving U.S., allied, coalition and partner military forces for airdrop operations to support training objectives or contingency response employment and sustainment requirements.

3.13.1.5. USAF Weapons School (USAFWS) Personnel. USAFWS Weapons Officer cadre and specified civilian contract personnel supporting USAFWS Weapons Officer training perform DZC duties at all approved CONUS DZs in support of USAFWS Weapons Officer training syllabi.

3.13.1.6. USAF Operations Group Personnel. The Operations Group Commander (OG/CC) may certify RegAF, ANG, AFR members and DoD civilian and/or contract personnel to perform DZC duties during unilateral AF training airdrops within that OG/CC's local training area. ANG/AFR Dual Status Technicians may perform these duties in a technician status. The OG/CC should utilize airlift operations oriented personnel to act as DZCs. These personnel must be a Non-Commissioned Officer (NCO) with at least 5 years of service, a commissioned officer, or a DoD civilian/contractor (previously certified USAF DZC) with specific DZC duties as part of their job requirements. **(T-3).**

3.13.2. Other DoD Personnel. Qualified DoD or Joint Service personnel may perform DZC duties.

3.13.2.1. U.S. Special Operations Command (USSOCOM). In addition to AFSPECWAR, USSOCOM units have certified personnel who may perform DZC duties during joint and unilateral USSOCOM training and/or operations, such as: U.S. Navy Sea Air Land teams and Explosive Ordnance Disposal units; U.S. Army Special Forces and Ranger Regiment; and U.S. Marine Corps Special Operations Forces. Personnel who have completed qualification training, are certified and current in accordance with [paragraph 3.13.4](#) may perform DZC responsibilities listed in [paragraph 3.13.5](#).

3.13.2.2. U.S. Army or Marine Corps DZ Support Team (DZST). DZST personnel may be certified to perform DZC duties during joint and unilateral AF airdrops in accordance with the USAF, U.S Army, and U.S. Marine Corps Memorandum of Agreement, *Airdrop Operations Without Air Force Combat Control*. DZST normally have a qualified DZSTL in charge of DZ operations.

3.13.2.3. Non-DZ Support Team Personnel. When trained and certified DZST personnel (e.g., Pathfinders) or USAF personnel (e.g., CCT/STO) are not available to perform DZC responsibilities, the OPCON MAJCOM/A3, Air Component Commander or designated authority may approve a CCT/STO, or AMLO to train personnel identified by the ground mission commander to perform DZC duties. These personnel must meet the following criteria to perform the duties in [paragraph 3.13.5](#): An NCO with at least 5 years of service or a commissioned officer. **(T-0)**. A CCT/STO or AMLO will train personnel in accordance with [paragraph 3.13.4](#) **(T-0)**. The member's Group/CC or equivalent O-6 commander must certify the training in writing. **(T-0)**. Non-DZST personnel may only perform DZC duties on the DZ(s) and for the specified durations(s), authorized by the Air Component Commander or designated authority.

3.13.3. Non-US Personnel. The MAJCOM/A3, Air Component Commander, or designated authority with OPCON of the drop aircraft will approve airdrops of U.S. forces or equipment to another nation's military personnel (non-U.S. DoD). **(T-0)**. Airdrop(s) to a DZ controlled or operated by a foreign nation DZC will be in accordance with [paragraph 3.13.5](#) only during contingencies or combined exercises if qualified, certified, and current USAF or other DoD DZC personnel are not available or it is a mission requirement. **(T-0)**. Qualified, certified, and current USAF or other DoD personnel should assume control of DZ operations as soon as operationally feasible in contingency operations. Other nations' personnel selected from forces trained and certified by their parent service, in an equivalent or similar specialty or duty identifier (Air Force Specialty Codes [AFSC], Military Occupation Specialty (MOS), or advanced qualification similarity), shall be trained and certified in accordance with [paragraph 3.13.4](#) to perform DZC duties for a specific exercise or contingency event. **(T-0)**. When possible, if the foreign personnel DZC is not an American-English speaker, the foreign personnel and the aircrew that will fly the mission should talk prior to the airdrop mission to ensure variations in enunciation are understood prior to radio contact during the mission. **(T-2)**. **Exception:** Operations Group/CC or designated authority of the drop aircraft shall approve non-US trained and certified Partner Nation DZC for contingencies and combined exercises in accordance with [paragraph 1.2 International Agreements](#). **(T-0)**. In addition, the Operations Group/CC or designated authority of the drop aircraft shall ensure incident reporting procedures and responsibilities are established specific to all partner nations conducting operations.



3.13.4. DZ Personnel Qualification Training, Certification and Continuation Training. All personnel authorized in accordance with paragraph 3.13.1 – 3.13.3 will accomplish qualification training, certification and continuation training specified in this paragraph and as specified by AFSC/MOS-specific AFI, AFMAN, Career Field Education and Training Plan (CFETP), Joint Qualification System, or Joint Service DZSTL curriculum. (T-0). See specific MAJCOM or Joint Service guidance for additional training eligibility and restriction criteria. At a minimum, the unit tactics, group tactics office or equivalent office will maintain a current list of personnel certified. (T-0). J3 Air office or designated Joint unit should maintain a list of Joint Service certified personnel.

3.13.4.1. USAF Personnel (RegAF, ANG and AFR), DoD Civilians, or Contractors. For USAF, AFSOC is designated as the lead MAJCOM. MAJCOMs (AFSOC Wing or Group) shall develop DZC lesson plans to minimum standards identified in this manual and the AFSOC Training (AFSOC/A3T) DZC Syllabus of Instruction (SOI). (T-1). All DZCs will be initially trained to attain proficiency (academic training and practical training involving day and night DZ operations) in DZC responsibilities, duties and DZ establishment. (T-2). A current and certified DZC who is a qualified instructor, trainer, certifier, or a sister service DZST, shall conduct training. (T-2). The DZC will be an E-4 or above with a five skill level or higher and the unit commander will certify the DZC. (T-3). **Exception:** An operations group personnel's Group/CC or equivalent O-6 commander will certify the DZC in accordance with paragraph 3.13.1.6. (T-3). All USAF certified DZCs must review MAJCOM guidance when assigned to a new MAJCOM. (T-2).

3.13.4.2. Non-DZ Support Team Personnel. Train and certify non-SOF, non-DZST personnel in accordance with paragraph 3.13.2.3. (T-1).

3.13.4.3. Non-US Personnel. The MAJCOM/A3, Air Component Commander, or designated authority with OPCON of the drop aircraft in accordance with paragraph 3.13.3, must approve drop operations to non-U.S. personnel. (T-0). In accordance with the MAJCOM-approved training plan, either a USAF CCT (1Z2X1) E-4 or above with a 5-skill level or higher, STO, AMLO, or a qualified, certified, and current Air Advisor will train non-U.S. personnel designated by a non-U.S. unit commander; and the U.S. unit commander providing the qualification training will certify the non-U.S. personnel as trained. (T-0). It is the non-U.S. unit commander's responsibility to coordinate training. Complete training during pre-deployment preparation. The instructor will document the certification using a memorandum for record. (T-0). When feasible, the U.S. unit commander should provide certification documentation to the supporting MAJCOM/A3, Air Component Commander, or designated authority prior to non-U.S. personnel accomplishing DZC duties on DZs supported by aircraft governed by this DAFMAN. **Exception:** Operations Group/CC or designated authority of the drop aircraft shall approve non-US trained and certified Partner Nation DZC for contingencies and combined exercises in accordance with paragraph 1.2 International Agreements. (T-0). International Agreements include but are not limited to AFSOC/A3T validated Australia Department of Defense Learning Management Package (AUS-LMP) *Assault Zone Reconnaissance Course* and STANAG 3344, Tactics, Techniques, and Procedures for NATO Airborne Operations. In addition, the Operations Group/CC or designated authority of the drop aircraft shall ensure incident reporting procedures and responsibilities are established specific to all partner nations conducting operations.



3.13.4.4. Continuation Training. Authorized personnel must set up and control a surveyed and approved DZ in accordance with this manual and AFSC/MOS continuation training guidance. **(T-2)**. Authorized personnel in AFSC that do not have DZC as a core skill will set up and control a surveyed and approved DZ in accordance with this manual once every 24 months to maintain DZC currency. **(T-2)**. Personnel who fail to accomplish this DZC event once every 24 months will not perform DZC duties unless directly supervised by a current and certified DZC. **(T-2)**.

### 3.13.5. DZC Responsibilities.

3.13.5.1. The DZC represents the appropriate commander as provided in the mission directive.

3.13.5.2. Prior to personnel airdrops, the DZC ensures adequate medical, evacuation, and support coverage for intentional water operations in accordance with AFI 10-3503. **(T-2)**.

3.13.5.3. The DZC observes and evaluates:

3.13.5.3.1. All factors that may adversely affect the safety of the operation and ensures transmission of weather information when required.

3.13.5.3.2. Condition of the DZ prior to the airdrop.

3.13.5.3.3. Placement of personnel and equipment on the DZ. Only designated vehicles (watercraft for intentional water DZ) and personnel will remain on the DZ. **(T-2)**. The DZC will position recovery and medical personnel and equipment so that constant contact is maintained with the DZC. **(T-2)**. During joint operations, the DZC and the DZSO are responsible for their respective equipment and personnel. **NOTE:** For actual equipment or personnel airdrops, if the ceiling is less than 600 feet, direct all personnel and equipment off the DZ to ensure safety.

3.13.5.3.4. The operation of other aircraft that could endanger the drop aircraft, equipment load, or parachutists.

3.13.5.4. The DZC will have immediate access to ground-to-air communications equipment or sufficient signaling aids to operate the DZ. **(T-2)**. Ground-to-air communication is required for IMC airdrops.

3.13.5.5. The DZC should ensure non-DZC personnel on or in the vicinity of the DZ are aware of the "NO DROP" signal in order to prevent an inadvertent signal to the aircraft.

3.13.5.6. In the event conditions are unsafe for airdrop operations, the DZC ensures: **(T-2)**

3.13.5.6.1. "NO DROP" signals are displayed on the DZ.

3.13.5.6.2. "NO DROP" or drop cancellation information is transmitted to the aircraft.

3.13.5.6.3. The airdrop is cancelled.

3.13.5.6.4. The use of standardized "off DZ" terminology during all DZ operations related to strike reports and assertive statements for "off DZ" events. The DZC also ensures "Cease Operations," "Time-out," and/or "Knock It Off" are used in accordance with [paragraph 3.15](#). **NOTE:** Airdrops are not suspended or canceled based solely on

aircraft alignment with the DZ, but the DZC may advise the aircraft if their alignment appears to be off course.

3.13.5.7. The DZC will conduct drop scoring in accordance with [paragraph 3.14](#). (T-1).

3.13.5.8. The DZC ensures necessary reports, to include AF Form 4304, *DZ/Landing Zone Control Log* (**Attachment 7**), are properly filled out and submitted to the appropriate agencies.

3.13.5.9. The DZC may perform malfunctions officer duties if qualified, certified and current in accordance with AFJ 13-210(I), *Joint Airdrop Inspection Records, Malfunction/Incident Investigations, and Activity Reporting*.

3.13.5.10. The DZC will acquire and utilize the current applicable DZ survey(s). (T-1). The DZC assesses all observed obstacles, hazards, or threats not documented on the surveys, which may affect operations and reports them to the appropriate supporting and supported forces. The DZC should maintain Talon Point accounts for access to current DZ surveys and to view and submit assessments.

3.13.5.11. The DZC is responsible for all DZSO responsibilities listed below when a DZSO is not required.

### 3.13.6. DZSO Responsibilities.

3.13.6.1. The USAF does not require a DZSO for DZ operations. When a non-USAF supported force requires a DZSO in addition to the DZC, a DZSO should be provided by the ground mission unit. When required, the DZSO represents the ground mission personnel and equipment and is responsible for the DZC duties listed below.

3.13.6.2. The DZSO represents the supported commander as provided in the mission directive.

3.13.6.3. The DZSO ensures adequate medical coverage is available at the DZ prior to any personnel drops. The supported unit normally provides medical coverage during joint operations.

3.13.6.4. The DZSO clears the area around the PI of all personnel and equipment not required for control or as designated to remain (25 yards/23 meters radius around the PI).

3.13.6.5. The DZSO determines when surface conditions (e.g., winds, vehicles, obstructions) on the DZ are hazardous to airborne or drop operations. The DZSO decides to proceed with, suspend or cancel airdrops, and informs the DZC not later than two minutes prior to the drop. Use standardized "off DZ" terminology during all DZ operations related to strike reports and assertive statements for "off DZ" events; "Cease Operations," "Time-out," and/or "Knock It Off" in accordance with [paragraph 3.15](#).

3.13.6.6. The DZSO coordinates all no-drop, medical and emergency actions with the DZC.

3.13.6.7. The DZSO ensures the condition of the DZ do not affect operations or recovery of air items.

3.13.6.8. The DZSO ensures the DZ meets operational and safety criteria for the type of airdrop operations being conducted.

3.13.6.9. Placement of personnel and equipment on the DZ. Only designated vehicles (watercraft for intentional water DZ) and personnel will remain on the DZ. **(T-2)**. DZSO will position recovery and medical personnel and equipment so that constant contact is maintained with the DZSO. **(T-2)**. During joint operations, the DZC and the DZSO are responsible for their respective equipment and personnel. **NOTE:** For actual equipment or personnel airdrops, if the ceiling is less than 600 feet, direct all personnel and equipment off the DZ to ensure safety.

3.13.6.10. The DZSO ensures a qualified, certified and current malfunctions officer is present for airborne operations. The DZSO may perform malfunctions officer duties if qualified, certified and current in accordance with AFJ 13-210(I).

**3.14. DZ Scoring.** Drop scoring is the responsibility of the DZC.

3.14.1. Strike Reports. The strike report reflects the circular error or the distance that the targeted object (or parachutist) lands from the PI; if a targeted bundle is not pre-coordinated, score the first bundle to exit the aircraft. Strike reports are given in yards or meters and relative clock position from the PI with 12 o'clock as the relative DZ axis heading.

3.14.1.1. Score object impacting within a 25 yard/23 meters radius of the PI as a "PI."

3.14.1.2. Score the accuracy of mass airdrops during joint training and/or exercises, SOF standardization/evaluation events and high velocity airdrops as "Satisfactory" if 90 percent or more of all airdropped personnel or equipment lands within the boundaries of the DZ, (not considered "off DZ" in accordance with [paragraph 3.15](#)) Score these drops as "Unsatisfactory" if less than 90 percent lands within these boundaries, (considered "off DZ" in accordance with [paragraph 3.15](#)) Mass airdrops for personnel are considered approximately battalion size or larger or as intended by mission directive. Both personnel and equipment airdrops may be scored using mass airdrop criteria if the accuracy is indeterminable.

3.14.1.3. MFF and/or DBSL Airdrops. Do not score MFF and/or DBSL airdrops. Annotate actual TOTs and information relevant to any mishap or off-DZ drops. **NOTE:** Airdrops to a DZ smaller than the minimum size (waivered DZ size criteria) are scored based on the DAF minimum DZ size criteria. For example, a waivered DZ is 100 yards short of DAF minimum size. The drop is considered on the DZ if personnel or equipment land within the 100-yard difference between the minimum and waivered DZ boundaries.

3.14.2. Scoring Methods. There are three methods to score airdrops, and they are listed by preference. Only score the first load or parachutist exiting from each aircraft. **(T-2)**.

3.14.2.1. Measuring. The distance from the PI to the load is measured when precise scores are required. The distance is measured using a precision measuring device (e.g., odometer, laser range finders, measuring tape, cyclometer, GPS).

3.14.2.2. Pacing. Physically pace the distance from the PI to the place where the parachutist or equipment load landed to measure the score.

3.14.2.3. Estimating. Used when there is insufficient time or personnel to pace. The distance from the PI to the load is visually estimated. To assist in scoring by this method, place markers (visible from the PI) at desired locations from the PI at the 3, 6, 9 and 12 o'clock positions. If the markers are used, indicate this to the aircrew.

**3.15. Off DZ and Airdrop Malfunction Reporting Procedures.** In addition to the paragraphs below, users will refer to AFJ 13-210(I). **(T-0). NOTE:** Off DZ personnel landings do not always constitute an “off DZ drop” with steerable parachutes for static line and military freefall. Off DZ personnel landings may be non-reportable if it is determined that the jumper’s canopy manipulation was predominantly responsible for the landing placement and no injuries or equipment damage occurred. Before determining the incident to be non-reportable and resuming jump operations, the AC, JM and DZC must unanimously concur that the release point was accurate, the off DZ impact point was predominantly due to the jumper’s canopy manipulation and that no other contributing factors may affect continuing operations. **(T-2). Warning:** When an “off DZ drop” has been confirmed or suspected, the aircrew involved will not attempt another drop for the remainder of the mission. **(T-2).** In the case of an off DZ drop involving injury or death to personnel, the mission will be terminated and the aircraft will land as soon as possible. **(T-2).** Standardized “off DZ” terminology during all DZ operations related to strike reports and assertive statements for “off DZ” events; "Cease Operations," "Time-out," and/or "Knock It Off."

3.15.1. On-site/Aircraft Actions. Keep all systems running, do not delete any data, save GPS trail (if available) and retain all mission paperwork involved in flight to aid in an investigation. Aircrews will immediately report information regarding off DZ airdrops that result in damage, serious injury, or death to a USAF command post. **(T-0).** Notify unit tactics and safety offices as soon as possible. **(T-2).** Refer off DZ mishaps resulting in death or serious injury to safety and accident investigation boards convened under the applicable regulations. **(T-1).**

3.15.2. Airdrop Incident On-site/Aircraft Actions Planning. Units with DZC/DZSO/DZST responsibilities will develop local procedures and communications processes to obtain emergency assistance to preserve life and limb, secure the site and notify the airlift and user's chain of command. **(T-2).** The first notification step should be through the airdrop aircraft for relay to a USAF command post. Alternative means may include relay through any local U.S. military installation. Local installations may also be able to assist with emergency response resources including, aircraft rescue and firefighting, law enforcement and public affairs.

3.15.2.1. Wings/operations groups will develop guidance for aircrews and DZ personnel for the capture and reporting of in-flight data relating to an off-DZ airdrop and/or airdrop malfunction. **(T-2).** This data must have enough detail to re-create the circumstances surrounding the incident for the aerial delivery review panel. **(T-2).** Accurate and timely capture of data is critical and is the responsibility of the AC. **(T-2).**

3.15.2.2. Aircrews involved in an airdrop malfunction will not attempt another drop for the remainder of the mission unless approved by the unit’s Group/CC or O-6 equivalent, or the USAF base airlift Group/CC or O-6 equivalent from which the mission was launched and returned. **(T-0).**

3.15.3. Aerial Delivery Review Panel Appointment. The aircrew’s Group/CC, or equivalent, shall appoint an aerial delivery review panel to investigate all off DZ airdrops. **(T-0).** However, when performing off-station airdrop missions hosted at an AFB with an AF airlift/airdrop unit, the aircrew’s Group/CC or O-6 equivalent may authorize the host unit Group/CC or O-6 equivalent to perform the aerial delivery review panel in accordance with [paragraph 3.15.5](#) Panel members should include the Operations Support Squadron (OSS) or OG chief of tactics (OSK or OGK, respectively) as chairperson; a tactics pilot, navigator or combat systems officer and loadmaster; a Stan/Eval pilot, navigator or combat systems officer and loadmaster; airdrop

inspector loadmaster, flying safety officer and crewmembers from the incident. The ground unit's JM may also participate in the aerial delivery review panel when the ground unit is involved in the off-DZ drop. The chairperson may modify panel composition based on the nature of the situation under review.

3.15.4. Reportable Airdrop Incidents. The flight safety officer will determine if the airdrop incident is reportable in accordance with AFI 91-204, *Safety Investigations and Hazard Reports*. **(T-1)**. Prepare the aerial delivery review panel to provide information requested for a safety investigation and report, if warranted. **(T-1)**. Normally, the DAF reports injuries and damage to their own personnel and equipment. Other military services report injuries and damage to their own personnel and equipment. The DAF takes part in these investigations when requested by the other service. **(T-1)**.

3.15.5. Aerial Delivery Review Panel. Convene an aerial delivery review panel NLT the next duty day after the airdrop if the incident occurs in the local area. However, if the incident occurs away from home station at a location without an DAF airlift/airdrop unit, convene the panel within five duty days (ten days for ANG and AFR units) after the aircrew returns to home station. The unit's Group/CC or O-6 equivalent is the approval authority to allow aircrew to continue airdrop operations away from home station at a location without an DAF airlift/airdrop unit. Unit commanders will ensure aircrew members involved in an off DZ airdrop are not scheduled for any event that would delay convening an aerial delivery review panel or for another airdrop until the incident is resolved. **(T-2)**. Upon completion of the aerial delivery review panel, the chairperson will submit recommendations to the Group/CC or O-6 equivalent; if the option listed in [paragraph 3.15.3](#) is used, then the host unit Group/CC or O-6 equivalent will inform the aircrew's Group/CC or O-6 equivalent of the panel's recommendations. **(T-2)**. The unit's Group/CC or O-6 equivalent will make the final determination regarding any panel recommended actions. **(T-2)**.

3.15.6. Off-DZ Report Repository. AMC Tactics (AMC/A3DT), [amc.a3dt@us.af.mil](mailto:amc.a3dt@us.af.mil), shall be the repository for all DAF off-DZ reports. **(T-1)**. AMC OSS tactics offices will send the results of their delivery review panel by memorandum, message, or e-mail to AMC/A3DT within 3 duty days after the panel convenes. **(T-1)**. Non-AMC units will forward their report to AMC/A3DT through their MAJCOMs NLT 30 calendar days after the incident. **(T-1)**. If the aerial delivery review panel determines the incident to be of immediate interest to other airdrop units, send an immediate message outlining significant details and recommendations to AMC/A3DT with an information copy to the parent NAF.

3.15.7. Aerial Delivery Review Panel Report Results. As a minimum, the aerial delivery review panel results will include the following information in their final report with: date of incident, type aircraft, unit, type load, DZ name and location, type drop (SKE, visual, or computer drop), day/night, formation position, drop score (clock position and distance) and surface winds. **(T-1)**. The report will also include causes and recommendations. **(T-1)**.

**3.16. DZ Surveys**. DZ survey accomplishment is the responsibility of the using organization. Users must ensure the survey is completed, meets the mission requirements and meets the applicable operational and safety standards. **(T-2)**. AF Form 3823 is completed in accordance with [Attachment 4](#). Until users complete all steps (survey, ground operations approval, safety of flight review and final approval), AF Form 3823 will not be usable and valid. **(T-2)**. **NOTE:** DZ surveys expire 5 years from the date surveyed and [Chapter 2](#) applies. **Warning:** Prior to using a DZ



survey, the aircrew must ensure the DZ meets operational and safety requirements for their type aircraft, the airdrop type and the weather conditions during the airdrop period. (T-2).

3.16.1. Training Requirement. Except for operations described in paragraphs [3.16.1.1](#), [3.16.1.2](#), [3.16.1.3](#) and [3.16.1.4](#), USAF personnel must require a USAF approved DZ survey for all training airdrop missions. (T-2).

3.16.1.1. Parachute Demonstration Team DZ Surveys. Office of the Assistant to the Secretary of Defense for Public Affairs ATSD(PA) MAJCOM sponsored parachute demonstration team operations (e.g., “Wings of Blue”, “Golden Knights”, “Leap Frogs”, “Para-Commandos”, “Black Daggers”, “Silver Wings”) do not require a formal DZ survey for public affairs coordinated high altitude low opening precision parachute demonstrations using DAF aircraft. It is the responsibility of the demonstration team leader/JM to ensure all service, Federal Aviation Administration (FAA) and hosting organization requirements are met on and around the DZ. It is the responsibility of the parachute demonstration organization to file applicable NOTAMs with the FAA. It is the responsibility of the flying unit to ensure flight safety will not be compromised. (T-1). It is the responsibility of the flying unit, the demonstration team leader/JM to ensure all parties involved are briefed and understand all aspects of the planned operation. (T-0).

3.16.1.2. Host Nation (HN) DZ Surveys. When dropping HN military jumpers and/or equipment on a HN surveyed DZ, the mission may be performed using only a safety of flight review, per [paragraph 3.16.5](#) and a HN survey, per [paragraph A4.2](#) A certified DZC is required and users remain responsible for ground operations and safety.

3.16.1.3. Austere Polar DZ Surveys. Due to the austere and inaccessible nature of Polar Regions, a physical inspection of the DZ may not be possible. For polar operations, a tabletop review of the austere polar DZ performed by 109<sup>th</sup> Operations Support Squadron Weapons and Tactics (109 OSS/OSK) will be an acceptable alternative to a DZ survey. (T-2).

3.16.1.4. Tactical DZ Surveys. Refer to paragraphs [3.3.2](#) and [3.16.7](#) for restrictions and criteria. The use of AF Form 3823 is not required for a tactical survey. As much information as practical will be obtained and provided for review, approval and use. (T-2).

3.16.2. DZ Surveyor. DZ Surveyors should be U.S. DZC, DZSO, or jumpmaster personnel. There is no qualification/training required to fill out an AF Form 3823 in accordance with [Attachment 4](#). Surveys will be completed, reviewed and approved in accordance with [Chapter 2](#) and paragraphs [3.16.3](#) – [3.16.8](#). (T-2). **NOTE:** Reference paragraphs [3.3.2](#), [3.16.7](#), and [3.16.1.4](#) for tactical DZ requirements. RAAF CCT that meet qualification, certification and currency in accordance with AFSOC/A3T validated AUS-LMP *Assault Zone Reconnaissance Course* and this manual are approved to conduct AF Form 3823 and tactical DZ surveys for USAF approval and/or use.

3.16.3. Surveying DZs. The surveyor will perform the ground portion of the DZ survey (i.e., obtain physical or digital maps and elevations, collect measurements, coordinates, relative elevations, calculate size, create diagrams and annotate results on AF Form 3823). (T-2).

3.16.3.1. Tasking. The surveyor is tasked in accordance with [paragraph 2.3.1](#) and shall support the requirements within the task or survey request to include identification of all potential uses and users of the zone (e.g., ground units, flying units, supporting units and

aircraft types). (T-2). Additionally, as applicable, the surveyor should clarify any requesting user intent and conduct surveyor pre-production/pre-coordination prior to physical inspection on-site.

3.16.3.2. DZ Surveyor Guides. For personnel that do not regularly conduct DZ surveys, MAJCOMs and Joint Services may publish DZ surveyor guides that may be found on local systems, MAJCOM systems, or uploaded to Talon Point database. Build and update the guides to reduce survey processing delays.

3.16.3.3. Physical Inspection. The ground surveyor will conduct a physical inspection of the entire proposed DZ surface to identify and evaluate potential hazards. (T-2). **Exception:** Physical inspection limitations in accordance with [paragraph 3.16.3.3.1](#) and open water DZs in accordance with [paragraph 3.16.3.3.2](#). The surveyor will identify hazards to DZ operations located within 1000 meters/1094 yards of DZ boundary. (T-2). Additional surface area within 5 NM of the planned DZ center point should be evaluated by physical inspection, map study, aerial photography, GPS and/or electronic mapping tools for hazards to airdropped personnel and/or equipment, man-made or natural structures and ground personnel.

3.16.3.3.1. Physical Inspection Limitations. Operational threats and mission parameters may limit the surveyor's ability to physically inspect the proposed DZ and surrounding areas. The surveyor will inspect as much area as possible within 5 NM of the proposed DZ center point. (T-2). Areas not accessible will be inspected through stand-off means to the greatest degree possible. (T-2).

3.16.3.3.2. Open Water DZs. Proposed water DZ locations that do not have land terrain features within 2 NM may be surveyed without a physical inspection. If not conducting physical inspection, the surveyors must carefully review nautical charts and maritime data to identify potential hazards on or in the vicinity of the DZ (e.g., buoys, navigation markers, maritime shipping routes). (T-2). Evaluate the surface area within 5 NM of the planned DZ center point. (T-2).

3.16.3.4. Hazards, Obstacles and Restrictions. Annotate all types of hazards, obstacles, restrictions and distance requirements as listed in [paragraph 3.5](#).

3.16.3.5. Surveyor Submission. Submit the completed AF Form 3823 for review in accordance with [Chapter 2](#). The surveyor is responsible for the accuracy of the survey data forwarded for review. Other reviewers may add additional information to AF Form 3823. Coordinate changes to surveyor data with surveyor. (T-2).

3.16.4. Ground Operations Approval. The ground operations review authority is a commander's designated representative documented as capable of performing DZ control and surveying. The ground operations review authority ensures the survey form is complete, accurate and that the DZ meets the criteria for planned ground operations. The review authority will also ensure that coordination has been accomplished with the requesting unit if the data for the surveyed DZ did not support any specific requirements submitted within the task. (T-2). The ground operations approval also fulfills the quality check duties in accordance with [paragraph 2.3.3](#). **NOTE:** Surveyor will not review their own survey. (T-2).

3.16.5. Safety of Flight Review. DZ surveys require a flight safety review and a signature certifying the review has been completed. This is the final review prior to the approval signature. As such, this review requires both the ground and flight portions of the DZ survey.

3.16.5.1. Safety of Flight Reviewers. The Group/CC or O-6 equivalent must document, in writing, personnel authorized to perform safety of flight reviews. **(T-2)**. Personnel must have documented USAF aircrew airdrop experience as a rated officer. **(T-2)**. Group/CCs or equivalents should utilize current/previous rated officer airdrop instructors but are not prohibited from using other personnel as long as all requirements are met. In the event personnel in the same unit that conducts safety of flight reviews also survey the DZ, the safety of flight review will be conducted by a different person. **(T-2)**.

3.16.5.2. The Air Component Commander, COMAFSOF, or equivalent, may designate safety of flight reviewers to perform safety of flight reviews on DZ surveys.

3.16.5.3. Air Operations Center (AOC)/Air Mobility Division (AMD). During contingency operations, the tactics office in the AOC/AMD may complete the safety of flight review.

3.16.5.4. MAJCOMs may accept and use DZ surveys reviewed and signed by other MAJCOMs and OPCON authorities.

3.16.5.5. For AMC OPCON assets only, AMC requires that surveys that are not routed thru a region tactics office receive an additional AMC review prior to use by AMC OPCON aircraft. **(T-2)**.

3.16.6. Safety of Flight Review Criteria.

3.16.6.1. Use a 1:50,000-scale chart and satellite imagery (if available) or MAJCOM approved flight planning software or system for the objective area and at least a 1:250,000-scale chart for the run-in and escape.

3.16.6.2. Ensure the form documents all required information. Refer to [paragraph 3.16.3](#) and [Attachment 4](#) for the list of items the surveyor must annotate on the form. Examples are: Terrain, towers, power lines avoidance areas and airspace. Add any required information to AF Form 3823 or consider rejecting the survey to the surveyor to add the required information to both block 10, DZ diagram and block 11, remarks, within the AF Form 3823.

3.16.6.3. Evaluate the DZ route of flight (run-in, drop and escape) to determine if there are obstructions or over-flight restrictions that may affect an aircraft's ability to achieve drop altitude and airspeed, conduct the drop and safely escape off the DZ. At a minimum, evaluate ingress and egress routes 10 NM from PI. **(T-2)**. If hazards/adverse conditions are identified, the run-in may be modified/restricted for safety reasons, the minimum drop altitude increased, or the safety of flight review denied.

3.16.7. Approving Authority Signature. Surveys must be signed by the Group/CC or O-6 equivalent or higher with authority over aviation missions or assets prior to the survey being used for DZ operations. **(T-2)**. Approval authority may be delegated to deputy Group/CC. This approval assures that the safety of flight review is complete and the DZ is considered safe for air operations. The approval authority does not accept the risks or the responsibility of other units utilizing the survey. Approval authority may also be the designated representative who



is performing duties as the Group/CC. Tactical DZ surveys do not require a signature and are approved for use in accordance with [paragraph 3.3.2](#).

3.16.8. Survey Submission. Submit the fully signed and completed survey in accordance with [paragraph 2.3.5](#).

## Chapter 4

### LANDING ZONE OPERATIONS

**4.1 General.** A LZ is any planned landing surface and movement area that has not been evaluated or does not meet defined airfield criteria. LZ may be unprepared, semi-prepared, or paved. LZ surveys quantify the risk of using a planned landing surface and movement area for air land operations and are not airfield certification documents. LZ operations governed under this DAFMAN must be conducted using a valid LZ survey unless on a valid airfield in accordance with **paragraph 4.2.5.(T-2)**. Aircrew use of short field operations does not drive the requirement for a LZ survey. The absence of published airfield information from an authorized source in accordance with AFMAN 11-202V3, *Flight Operations*, and the AFMAN 11-2MDS series drives the requirement for a LZ Survey. The use of assault procedures and LZ operations have a higher level of assumed risk than normal air land operations. This chapter outlines the basic criteria, markings and procedures used in support of LZs. It describes the responsibilities of the Landing Zone Controller (LZC), the Landing Zone Safety Officer (LZSO) and the LZ survey process.

#### 4.2. Responsibilities.

4.2.1. **Shared Responsibility.** It is the shared responsibility of the air mission commander and ground mission commander to ensure that any LZ being considered for use meets the requirements for the operation.

4.2.2. **USAF Aircrew.** Aircrew will only use LZ surveys when they have been trained and authorized by the MAJCOM to utilize LZ surveys. **(T-2)**.

4.2.3. **Standard LZ Traffic Vertical Obstruction Clearance Requirements.** The lead MAJCOM is responsible for determining and publishing vertical obstacle clearance criteria for each aircraft type listed in **Table 4.2** and in coordination with AMC Airfield Suitability and Restrictions Report (ASRR).

4.2.4. **Waivers to LZ Minimums.** Submit waivers to LZ survey data that does not meet **paragraph 4.3** LZ minimums in accordance with **paragraph 1.4** OPCON MAJCOM/A3, Air Component Commander, or designated authority may elect to accept waivers granted by other commands.

4.2.5. **Rated Airfields.** OPCON MAJCOM/A3 or Air Component Commander designates the authority level for formally identifying the need for a LZ survey. LZ Surveys are normally not required for air land operations to include assault zone procedures utilized on airfields with a Global Decision Support System (GDSS) Airfield Detail (Giant Report) assessment or airfields that have Flight Information Program products (e.g., Instrument Flight Rules or VFR supplements, instrument approach procedures). LZ surveys are required to airfields archived or referred to as LZs within GDSS Airfield Detail. For airfields, GDSS is the primary Mobility AFs repository of worldwide airfield suitability information (account with AMC required to gain access to link); <https://gdss.maf.ustranscom.mil>. **NOTE:** GDSS account is required in order to gain access using the URL. If an airfield needed for operations is listed in archived status within the Giant Report, then contact the AMC Airfield Help Desk to determine actions needed to allow operations at [airfield.helpdesk@us.af.mil](mailto:airfield.helpdesk@us.af.mil). A LZ survey should not be requested for an airfield listed in the Giant Report unless the airfield detail specifically states airfield use as a LZ, or if specific mission operations dictate a LZ survey requirement.

4.2.6. Approved LZ Surveys. For air land operations to LZs and airfields that require a LZ survey in accordance with [paragraph 4.2.5](#), users must ensure the LZ survey is completed, meets the mission requirements and meets the appropriate operational and safety standards. (T-2). AF Form 3822, *Landing Zone Survey*, or a *Tactical Landing Zone Survey*, is completed in accordance with [Attachment 5](#) or [Table A8.1](#) respectively. AF Form 3822 or *Tactical Landing Zone Survey* is not considered usable until all steps are completed: Survey, ground safety review, safety of flight review and approval signature (may be verbal approval for *Tactical Landing Zone Survey*). (T-2).

4.2.6.1. AF Form 3822 expires 5 years from the date surveyed. *Tactical Landing Zone Surveys* expire after mission(s) specified on survey.

4.2.6.2. For USAF aircrew, tactical LZs may be required to meet the appropriate commander's objective(s). Tactical LZs are contingency LZs identified and used when emergent, time critical operations, or operational environment do not allow for completion of AF Form 3822 process or an on-site physical survey of the objective area intended for landing/departing aircraft. Tactical LZs may be paved, semi-prepared, or unprepared. Only USAF units with a MAJCOM approved requirement as documented in a mission essential task list or as permitted by MAJCOM/A3 may use tactical LZs. **Caution:** Tactical LZs have the highest operational risk and highest risk of complete loss of aircraft and personnel.

4.2.6.2.1. Approval of the OPCON MAJCOM/A3, Air Component Commander, or designated authority is required prior to using a tactical LZ. The OPCON authority will also notify the lead MAJCOM of the use of a tactical LZ. (T-2).

4.2.6.2.2. CCT/STO surveyor will conduct the *Tactical LZ Survey*. If on-site physical survey of the objective area intended for landing and/or departing aircraft cannot be entirely accomplished by a CCT/STO surveyor, than the CCT/STO surveyor will validate all data required in [Table A8.1](#) and report data to the OPCON authority as the LZ subject matter expert. (T-2). OPCON authority will provide overall operational risk management of the LZ data and requirements to operations. (T-2).

4.2.6.3. Prior to operations, the AC must ensure the LZ/airfield meets operational and safety requirements for their type aircraft, the air land type, operations and the weather conditions during the air land period. (T-2). The AC is ultimately responsible for determining if the accepted cargo and fuel load will allow for both safe arrival and departure from any LZ/airfield. (T-2). ACs are the final authority to conduct risk analysis and mitigation for employment of their aircraft. The AC may conduct LZ assessments when a LZSO is not present as defined in [paragraph 4.3.3](#).

4.2.6.4. LZ operations require LZ Safety Officers (LZSO) unless waived by MAJCOM/A3, Air Component Commander, COMAFSOF (O-6) or equivalent. (T-2). LZSOs must assess and report on all LZ features (e.g., runways, taxiways, aprons, or helipads) required for operations prior to use and must confirm that the LZ meets data listed on the current LZ survey. (T-2). LZSOs are not required but may be tasked to perform LZSO duties on published airfields. When tasked, LZSOs must assess and report on all valid features required for operations prior to use and must confirm that the airfield meets data listed in GDSS airfield detail (Giant Report) assessment or flight information program products (e.g., instrument flight rules or VFR supplements, or instrument approach procedures). (T-2). LZSO assessment and reporting standards, responsibilities and duties

are specified in **Chapter 2, paragraph 4.3, paragraph 4.13.1, Attachment 9** and AMC ASRR.

4.2.6.5. OPCON MAJCOM/A3, Air Component Commander, or designated authority are responsible to ensure appropriate tasking of LZ site surveys. Determination of threat potential (permissive, semi-permissive, hostile) applicable to LZ surveyor personnel as defined in **paragraph 4.10** must be conducted prior to assigning an appropriate force to LZ evaluation operations.

**4.3. LZ Minimums.** The criteria contained in this DAFMAN is for the survey, evaluation and assessment of existing LZs. The criteria found in United Facilities Criteria (UFC) 3-260-01, *Airfield and Heliport Planning and Design*, is for the construction and rehabilitation of LZs. LZ's built to UFC criteria should meet minimums and require minimal verification efforts. For all airfields and LZs, Air Force Civil Engineering Center (AFCEC) is the authority for Weight Bearing Capacity (WBC). Surveyors will utilize Tri-Service Pavements Working Group Manual, (TSPWG M) 3-260-03.02-19, *Airfield Pavement Evaluation Standards and Procedures* in addition to this manual to identify, collect, analyze and report existing LZ strength. **(T-2)**. Make requests for changes to UFC 3-260-01, or TSPWG M 3-260-03.02-19 through the Whole Building Design Guide, [www.wbdg.org](http://www.wbdg.org). Define LZ minimums as WBC, geometrics/vertical obstruction clearances and LZ assessment. The evaluation of existing LZ and/or valid airfields data must meet LZ minimums identified in this manual to ensure airlift safety of flight based upon aircraft performance and suitability. **(T-2)**. Waivers to LZ minimums to conduct operations to existing LZs are defined in **paragraph 1.4**. **NOTE:** When evaluating existing LZs, OPCON MAJCOMs/Air Component Commanders should consider how operations may affect a LZ deterioration and maintenance requirements.

4.3.1. **LZ Strength Reporting.** Use LZ strength reporting to determine rated WBC of operating surfaces. Report LZ features (e.g., runway (rwy), taxiway, apron) as semi-prepared, paved, or unprepared. Report paved LZ strength by Pavement Classification Number (PCN). Report semi-prepared and unprepared LZ strength by controlling California Bearing Ratio (CBR) and soil type. Specifically, for semi-prepared strength evaluated LZs, (includes unprepared), surveyors will report the controlling CBR soil strength profile, identify the controlling layer and determine the single most restrictive CBR value/thickness for each LZ feature surveyed. **(T-2)**. Additionally, surveyors will report the number/type/depth of CBR readings and WBC & allowable passes (typically the largest suitable aircraft/weight for each feature). **(T-2)**. Surveyors will utilize the Unified Soil Classification System to report the LZ surface soil group name (e.g., gravel, sand, clay, silt, or mixture of types). **(T-2)**. Soil types have differing inherent properties and differing reactions to environmental conditions (e.g., moisture) that may increase or decrease LZ strength and/or suitability.

4.3.1.1. **Semi-Prepared.** Semi-prepared LZs refer to an unpaved LZ which has had some amount of construction or maintenance preparation. The surface may be native dirt, membrane, landing mat, or any combination of these. Surface preparation may include stabilization, adding an aggregate course, compacting in-place soils, matting, or non-traditional surfaces that do not pose a Foreign Object Damage (FOD) risk to the aircraft operations. The amount of engineering effort required to develop and maintain a semi-prepared LZ depends on the planned operation, the service life of the LZ and existing soil and weather conditions. Semi-prepared LZs do not have a set standard surface, so semi-prepared analysis does not have a single strength reporting value. This is due to the varied,

constantly changing surface and subsurface properties that affect LZ strength. (e.g., varied layer strengths, wet LZs may or may not have significantly reduced controlling CBR). Use surveyed soil type/moisture level/drying factors to predict estimated semi-prepared LZ potential use for air lands after rainfall events in accordance with U.S. Army Engineer Research and Development Center (ERDC) Geotechnical and Structures Laboratory guidelines. Evaluate semi-prepared airfields with various aircraft/allowable loads/evaluation criteria using the TSPWG M 3-260-03.02-19, or ERDC Tri Services Pavement-Transportation Computer Assisted Structural Engineering (PCASE) software programs; PCASE DCP application and AFSOC DCP applications. Careful analysis of the DCP data is required to ensure the layer data entered in the program represents the data determined in the field.

4.3.1.1.1. ACs shall review the survey to identify LZ feature(s) controlling layer, CBR values and soil type. **(T-2)**.

4.3.1.1.2. ACs shall review the survey when planning, upon having received an assessment, and/or when conducting an assessment(s) to determine capability to employ or mitigate a condition that may exist that could adversely affect aircraft operations. **(T-2)**. **NOTE:** Recurring use of a LZ with reduced strength risks has an increased potential for LZ surface distress. Operation planners may base planned operations around LZ survey strength to theorize a number of operational cycles before potential surface distress levels could negatively impact operations; Use the planned number of aircraft and configuration(s) and reported semi-prepared survey strength to identify predicted number of cycles. A single aircraft cycle consists of a single aircraft landing, all taxi and single takeoff. Aircraft cycles are not required to be reported nor tracked, and the distress level is theorized. Therefore, operations planning does not replace the requirement for assessment conducted in accordance with **paragraph 4.3.3**, it is not required in the LZ survey process, and it is not required for survey approval. Use surveyed controlling CBR profile and/or WBC/allowable passes to directly correlate cycles in accordance with **Attachment 9**.

4.3.1.2. Paved. Paved LZ analysis has a standardized reporting format. Conduct analysis in accordance with TSPWG M 3-260-03.02-19. **(T-2)**. LZ surveyors may be certified as airfield pavement evaluators to conduct paved runway evaluations. Mark a paved LZ on a Class A or Class B runway. The markings may be permanent or temporary but cannot interfere with permanent priority runway markings. Existing taxiways, airfields, roads, highways, or other paved surfaces are considered paved LZs as long as the surface is a rigid or flexible pavement. LZ Surveys for paved surfaces may include WBC information from a previously published strength report. Surveyors shall report paved LZ strength by PCN, (when strength evaluated as semi-prepared also report semi-prepared strength), as specified in **paragraph 4.3.1.1**, **paragraph 4.3.1.2.2** and **attachment 5, paragraph A5.1.10.2**. **(T-2)**.

4.3.1.2.1. Paved LZ Surveys Conducted Without Airfield Pavement Evaluations. For paved LZs where certified airfield pavement evaluators are not tasked nor a valid pavement evaluation exists, the LZ surveyor may collect data and report information collected (e.g., pavement thickness, distress conditions and where available, underlying soil strength). Additionally, surveyors will report the type of existing aircraft currently

using the paved surface. (T-2). Refer to [paragraph 4.3.1.2.2](#) below if thickness cannot be determined.

4.3.1.2.2. Nontraditional Surfaced LZ/Airfields. Surface treatments and macadams are evaluated as semi-prepared in accordance with [paragraph 4.3.1.1](#) and [4.3.3.4](#) for assessment. Consider sand asphalt pavement “surfaced flexible pavement” and use traditional PCI procedures for flexible pavements. Sand asphalt may lack the strength and durability needed for high tire pressures pay particular close attention to identify the extent and severity of distresses, including cracking, rutting, shoving, weathering, and raveling.

4.3.1.2.3. Non-Standard Paved Asphalt Airfields. For all asphalt paved LZ that do not generate an operationally usable PCN, evaluate the pavement cross-section as measured. This pavement will produce a reduced load-bearing capability and depending upon the intended mission (contingency, number of landings, gross weights), that capability may not be sufficient. (T-2). When the concern is to facilitate the aircraft mission in lieu of preventing pavement damage, determine the PCN, consider the pavement as a FOD sealer and evaluate/report semi-prepared strength in accordance with [paragraph 4.3.1.1](#) Operations may result in the destruction of the LZ surface. The damage caused by this destruction may constitute a FOD/surface distress hazard to both aircraft and ground personnel. (Specific MDS do create more LZ destruction than others). Decisions to utilize a LZ to the point of destruction will be made by the OPCON MAJCOM/Air Component Commander with Geographic Combatant Commander concurrence and should be limited to contingency operations only. (T-0). **NOTE:** Where possible, airfield managers, operators, maintainers, surveyors, or pavement evaluators should examine the pavement after each operation to identify and report load related distresses.

4.3.1.2.4. Paved and Nontraditional Surfaced Strength Review. Prior to Safety of Flight submission, the MAJCOM pavement engineer or MAJCOM designated representative qualified, certified and current in accordance with [paragraph 4.10.4](#), will review all paved and non-traditionally surfaced LZ surveys. (T-2). The MAJCOM pavement engineer or designee will confirm or determine pavement strength, suitability if applicable and submit remarks as appropriate on LZ survey. (T-2). Each MAJCOM will be responsible for establishing a pavement strength review process of paved LZ surveys that are evaluated using paved or semi-prepared failure criteria. MAJCOMs without MAJCOM pavement engineers or designees may request that AFCEC or other MAJCOM conduct review.

4.3.1.3. Unprepared. Unprepared (also referred to as unimproved) LZs are a strip of terrain without a complete engineering or active effort to prepare the surface. Unprepared LZs can be either temporary or permanent. Examples of unprepared LZs are dry lakebed LZs that have been used during suitable dry seasons since the 1950s. Unprepared LZs may deteriorate rapidly and may require more critical evaluation. Unprepared is evaluated and reported as semi-prepared in accordance with [paragraphs 4.3.1.1](#) and [4.3.3.4](#). (T-2).

4.3.2. LZ Minimum Geometrics/Vertical Obstruction Clearances. Select LZs to be of sufficient size to permit rapid takeoff, landing and loading operations. (T-3). [Table 4.1](#) and [Table 4.2](#) depict the minimum sizes for USAF fixed-wing aircraft. However, LZs are not



limited to the USAF standard traffic. **Table 4.2** depicts required LZ runway slopes, overruns and vertical obstruction clearances. **Figure 4.1** depicts required approach and/or departure vertical obstruction clearances. LTFW aircraft are any aircraft smaller than USAF C-130 aircraft. Identify additional LTFW and other aircraft minimums not listed in **paragraph 4.3.2** using paragraphs **A9.1-A9.2**, **Table A9.2**, **Figures A9.1** and **A9.2**. All minimums are based on the use of maximum effort take-off, landing and taxi procedures by arriving, departing and taxiing aircraft. Some minimums defined in this manual for operations to existing LZs may be less restrictive than minimums defined for new LZ construction. Build LZs in accordance with UFC 3-260-01, Chapter 7. **(T-0)**. MAJCOMs may publish additional LZ minimums in a MAJCOM supplement to this manual. Waivers to minimums defined in **paragraph 4.3.2**, **Table 4.1** and **Table 4.2**, **Figure 4.1** and **Attachment 9** will be processed in accordance with **paragraph 1.4. (T-2)**.

**Table 4.1. Minimum LZ Runway/Taxiway Length/Width for Standard Traffic.**

Type Aircraft	Length (Ft) (Note 1)	Width (Ft) (Note 3 & 4)			Taxiway
		No Turn Required	180 Degree Turn (Normal)	180 Degree Turn (3 Point)	
U-28/PC-12	2,000	30	30	30	23
MC-12	2,000	30	30	30	30
C-145	1,500	30/23	23	23	18
C-146	2,000	35/22	47.5	24.3	22
M/H/C-130H/J (Note 2&5)	3,000	60	60	50	30
C-130J-30 (Note 2&5)	3,000	60	85	75	30
C-17 (Note 5)	3,500	90	143	80	50

**Note 1:** Minimum lengths do not include any overruns. Minimum required overruns and use of overruns are defined in **Table 4.2** and **paragraph 4.3.2.2**. For aircraft that use ground roll criteria, refer to **paragraph 4.3.2.1**. Environmental conditions and mission parameters may increase length requirements due to a longer ground roll. Include climatology and a person familiar with the performance of the aircraft during the planning phase to preclude a mission cancellation due to insufficient LZ length. C-17 minimum LZ runway lengths at different pressure altitudes, operating weights, surfaces and runway condition rating (RCR) are found in UFC 3-260-01, Table 7-2.

**Note 2:** Calculated minimum runway length is ground roll plus (+) 500 feet, however all operations less than 3,000 feet require a waiver. **Exception:** Waiver not required for MC-130.

**Note 3:** LZ shoulders are not required for operational LZ evaluation (survey and/or assessment) and use, but are required for construction evaluation (survey of initial construction or repairs).

**Note 4:** Larger width is desired for normal operations. Consult MAJCOM guidance if desired, required, or planned use of a runway width is less than those listed in **Table 4.1. (T-3)**.

**Note 5:** The 180 degree turn (3 point) widths do not include a safety margin. Increase by ten feet for routine operations.

**Note 6:** LTFW Aircraft smaller than C-130 not identified in **Table 4.1**, refer to **paragraphs A9.1-A9.2, Table A9.2, Figures A9.1** and **A9.2**.



4.3.2.1. Ground Roll + Criteria. For all MDS, MAJCOM/Air Component Commander may authorize the use of ground roll + criteria. This approval will be documented in an approved DAFMAN, MAJCOM supplement to DAFMAN 13-217, MAJCOM instruction, or an approved Concept of Operations. (T-2). MAJCOMs may delegate reduction of these criteria for non-training mission. Notify AF/A3S of the delegation level via MAJCOM Supplement or signed memorandum. (T-1).

**Table 4.2. LZ Runway Slopes, Overruns and Vertical Obstruction Clearances.**

Type AC	Rwy length slope (Note 1)	Rwy Overrun Length (Note 2)	Glide Slope Ratio (GSR) (Note 4)
	Rwy slope change (Note 1)	Zone A Width/Height (Note 3)	
	Rwy width slope (Note 1)	Zone B Width/Height (Note 3)	
U-28/PC-12/ MC-12	± 4% longitudinal	0' minimum, 100' when available	12:1 (4.76°)
	Refer to operation manuals	19' 3", no obstacle higher than 4"	
	± 3% transverse	5' 4", no obstacle higher than 5'	
C-130	± 3% longitudinal	300' minimum	35:1 (1.64°)
	Refer to operation manual	35', no obstacle higher than 2' 9"	
	± 0.5-3% transverse	25', no obstacle higher than 6' 3"	
C-17	± 2% longitudinal	300' minimum	20:1 (2.86°)
	Refer to operation manual	35', no obstacle higher than 3'	
	± 0.5-3% transverse	33', no obstacle higher than 5'	
C-145A	± 6% longitudinal	0' minimum, 100' when available	8:1 (7.13°)
	Refer to operation manual	30' 7", no obstacle higher than 3'	
	± 4% transverse	7' 3", no obstacle higher than 5'	
C-146A	± 2% longitudinal	0' minimum, 100' when available	20:1 (2.86°)
	Refer to operation manual	28' 11", no obstacle higher than 3'	
	± 3% transverse	6' 11", no obstacle higher than 5'	

**Note 1:** Slope is in percent grade and length is in feet. Grades may be positive, negative and flat. Longitudinal effective gradient (Rwy length slope) must not exceed respective aircraft's value listed at any location along runway/overruns profile. **(T-2)**. Surveyors/LZSO should report longitudinal segment gradient change (Rwy slope change) values/locations that exceed  $\pm 1.5\%$  per 200'. The average transverse grade (Rwy width slope) of the runway must not exceed the maximum value listed. **(T-2)**. Record and report any surveyed or assessed individual transverse runway and/or overruns grade(s) that exceed the maximum using percent grade and location identified in +feet from the primary runway threshold. **(T-2)**. Utilize measured individual transverse values to analyze respective vertical obstruction clearances.

**Note 2:** Length is in feet and runway slopes apply. LZ overruns have the same WBC as the runway unless otherwise stated. LTFW do not require overruns.

**Note 3:** Width and height are in feet and inches. Measure Zone A width from edge of useable runway and Zone B from edge of Zone A (zones wrap around the entirety of the runway). Measure vertical obstruction heights relative to both the runway edge's elevations and slopes. Vertical obstruction width and height maximums assume that the aircraft will land/taxi within the useable runway/overruns and that the aircraft will not exceed 5° bank at touchdown or during movement. **(T-2)**. Zone A values account for potentially hazardous obstacles to the outboard nacelle and Zone B values to the wing tip, illustrated in **Figure 4.2**. Derive vertical obstruction width and height maximums for aircraft not listed in **Table 4.1** in accordance with **paragraphs A9.1-A9.2, Table A9.2, Figures A9.1 and A9.2**.

**Note 4:** Measure GSRs for approach and departure in run over rise (or %, angle); inner edge originates at the end of overrun or end of usable (both are the end of evaluated suitable surface) along the entirety of the width to the outside corners of B Zones. The length to and width of the outer edge of the approach departure vertical obstruction clearances are illustrated in **Figure 4.1**. Controlling GSR for a runway is derived by the most restrictive obstacle to air navigation (controlling obstacle) within the controlling region. The controlling GSR for at least one runway to a LZ shall meet the minimum GSR (departure obstacle clearance requirement) for the aircraft using the LZ. **(T-2)**. Obstacles within the reportable region that do not meet the minimum GSR do not drive the controlling GSR to the runway. Reporting standards are identified in **paragraphs A5.1.11.1. and A5.1.12.2**.

4.3.2.2. Use of Overruns. LZ overruns have the same WBC, slope and vertical obstruction clearance requirements as the runway unless otherwise stated, (LZ overruns, unlike published airfield overruns, are evaluated as part of the runway features unless otherwise stated). For mission accomplishment, use overruns to increase the runway length available for operations.

Figure 4.1. LZ Approach/Departure Vertical Obstruction Clearances.

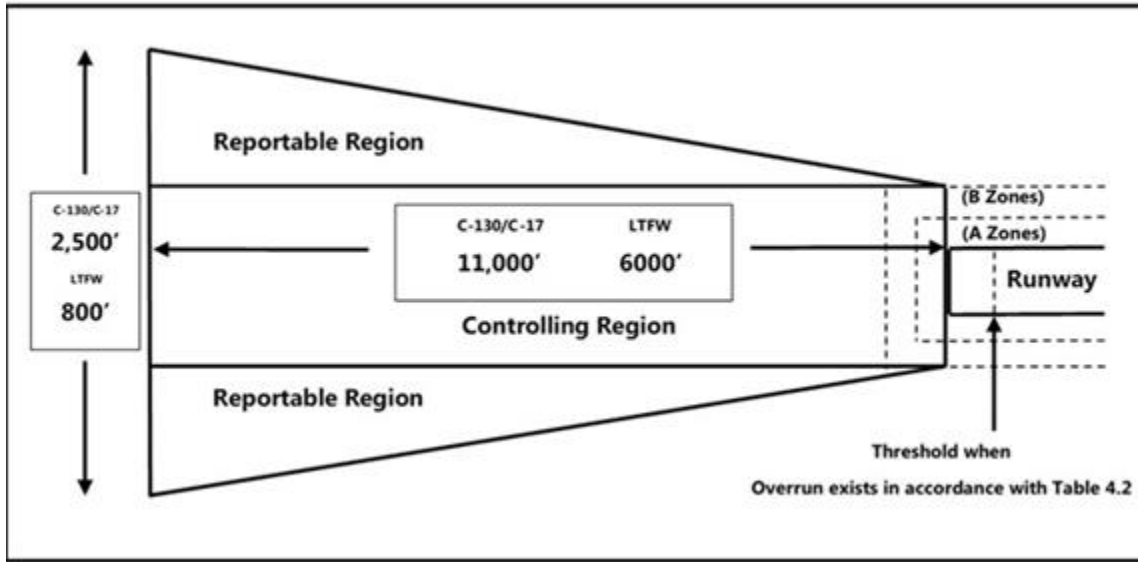
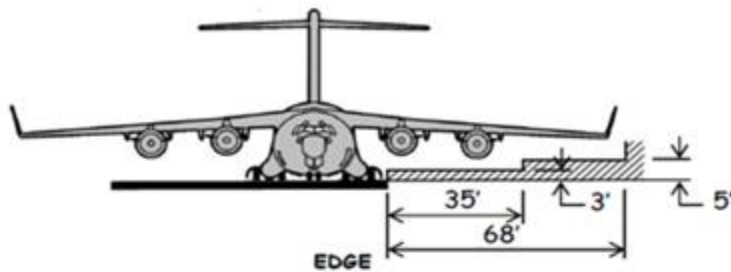
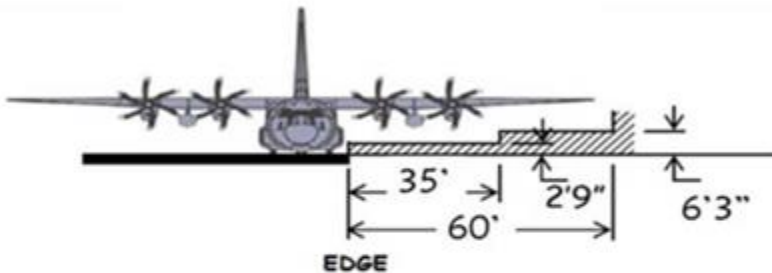

Figure 4.2. A and B Zone Vertical Obstruction Clearances.

C-17



C-130



C-146

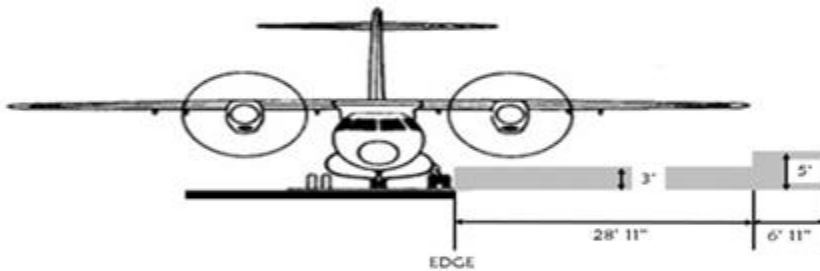

C-145

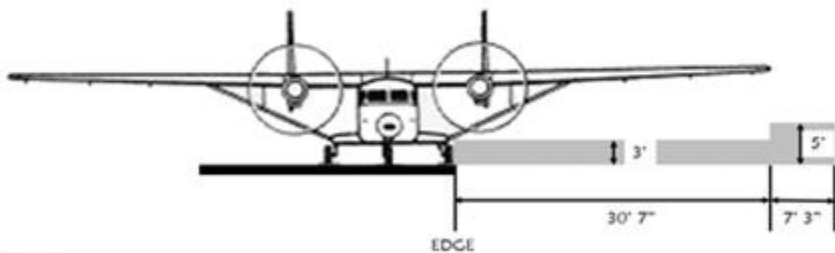

U-28/PC-12

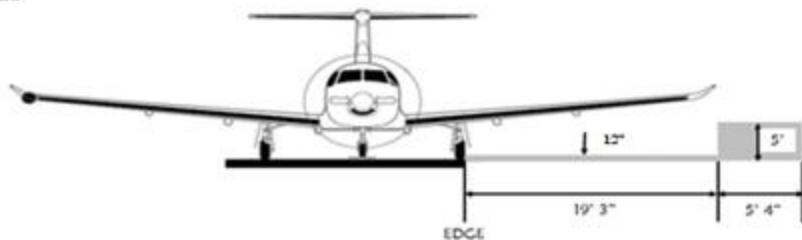

4.3.2.3. Use of LZ Displaced Thresholds. Displaced threshold is a runway threshold that is operationally required to be displaced farther beyond the surveyed primary threshold located in accordance with [Table 4.2](#) and [Figure 4.1](#) Displacement of a threshold may

reduce the length of runway available due to unusable runway surfaces, vertical obstructions, or controlling GSR required for departure. The portion of the runway behind a displaced threshold may be available for takeoffs and/or may be available for landing and/or rollout from the opposite direction in accordance with [paragraph 4.3.2.2](#) however dependent upon on the reason for the displacement. The controlling GSR terminates at the displaced threshold and must be at or beyond the primary threshold. **(T-2)**. Distance for required displacement originates from the most restrictive obstacle to air navigation, (controlling obstacle), within the controlling region. Identify and report all displaced thresholds, their GSRs and controlling obstacles in LZ surveys or assessments. **(T-2)**.

4.3.2.4. Accident Potential Zones (APZ) and exclusion areas for LZs. Limit or report APZ and exclusion area potential factors to safety of flight that may exist when possible. APZ and exclusion areas provide a reasonable level of safety for land usage within the confines of LZs. Potential hazards within APZs and exclusion areas are listed in [Table A9.1](#).

4.3.2.5. LZ Taxiway/Apron Slopes, Vertical Obstruction Clearances.

4.3.2.5.1. Slopes. Utilize [Table 4.2](#) “Rwy length slope” and “Rwy width slope” values for maximum taxiway length and width slopes not to exceed. Refer to aircraft operation manual for maximum taxiway and apron rate changes not to exceed.

4.3.2.5.2. Vertical Obstruction Clearances for Taxiways and Aprons. Utilize Zone A and Zone B vertical obstruction clearances listed in [Table 4.2](#) for both taxiways and aprons to identify and report all potential obstacle hazards to aircraft. For taxiway and aprons, aircrew will not taxi aircraft closer than ten feet to any vertical obstructions, nor within 25 feet of an vertical obstructions without a wing walker. **(T-3)**. Identify taxi obstacle distances and maximum heights allowed by aircraft not listed in [paragraph 4.3.2](#) to satisfy AFMAN 11-218, *Aircraft Operations and Movement on the Ground*. To assist in determining and reporting obstacles and in conducting safe taxi operations, refer to ASRR Chapter 6 and/or the MDS-specific Volume 3, or other specific guidance. Include the actual measured transverse slopes in the analysis of vertical obstruction clearances.

4.3.2.6. LZ Apron Parking Setback. Measured from the outer edge of usable runway surface to the setback line, aprons may be contiguous with the runway but parked aircraft and vehicles must be behind this line. **(T-3)**. Aprons are calculated as the total width of zone A and zone B, plus an additional 25'.

4.3.2.7. LZ Runway-Taxiway Separation. Measured from the outer edge of usable runway surface to nearest edge of parallel taxiway, LZ runway-taxiway separation is calculated as twice the total width of Zone A and Zone B, plus an additional 25'. **(T-2)**.

4.3.3. LZ Assessment. LZ assessment is the collection, analysis and dissemination of the LZ/airfield conditions for operations. They are typically collected on ground by physical inspection, but may be collected in air by aircrew or remote methods. On a LZ with a valid survey, a LZ assessment serves to report conditions that may affect safe operations during missions not limited to weather, environmental conditions, threats, surface distresses, braking action/RCR, or any changes to LZ survey or airfield. Also complete LZ assessments to validate the need for a LZ survey.

4.3.3.1. AC/aircrew will assess any conditions that affect aircraft performance or safety at a minimum and report to unit command and/or LZC/LZSO when present. **(T-3)**.

4.3.3.2. The LZSO, when present for operations, is responsible for collection and analysis of LZ data to ensure that the LZ/airfield meets the conditions listed on the current LZ survey, (or valid airfield's governing documents). LZSO will assess and report current LZ (or airfield) conditions to include deviations to surveyed conditions and/or safety concerns to unit command and AC/aircrew. **(T-2)**. **NOTE:** Aircrew, LZSO, support and planners may utilize Talon Point to acquire and/or input relevant and timely assessments when able to assist in safe operations and logistics. However, assessments in Talon Point do not fulfill responsibilities listed in paragraph **4.3.3.1** or **4.3.3.2** When a LZSO is not present for operations in accordance with **paragraph 4.2.6.3**, aircrews will conduct a minimum of one clearing pass prior to the initial touch down at an unattended LZ. **(T-2)**

4.3.3.3. Runway Condition Rating (RCR) and ICAO Braking Action. These values and terms are used by pilots to characterize the deceleration associated with the wheel braking effort and directional controllability of the aircraft. Aircrews use RCR and braking action to determine required runway lengths. The LZSO/LZC will report all available pilot-reported braking action and correlated RCR, or collected RCR and runway surface conditions, when changes in conditions exist. **(T-1)**. In accordance with **paragraph A9.4** and **Figure A9.4**, LZSO will conduct the vehicle skid tests at 20 mph and report RCR skid tested values as "estimated." **(T-2)**. RCR values and braking action for unpaved surfaces are listed in **Table A9.13** Estimated Unpaved RCR/ICAO Braking Action, and for paved surfaces in **Table A9.14** Paved Runway Condition Assessment Matrix (RCAM); also may refer to DoD Flight Information Program FIH for RCAM. LZSO/LZC will also utilize FAA Order JO 7110.65Y with Change 1-3, *Air Traffic Control Order*, para 3-3-4 and para **3-3-5** for RCR/braking action reporting procedures and example phraseology. **(T-0)**.

4.3.3.3.1. Skid tests/AFCEC approved methods or pilot reported braking action may not be possible to conduct and/or be available. LZSO or aircrew may utilize AFCEC guidance to estimate RCR of dry/wet semi-prepared surfaces to include matting or stabilized surfaces.

4.3.3.3.2. If any runway is evaluated to be flat (that is, if either half of the runway, based on centerline, is evaluated to be between -0.5% and +0.5% transverse section gradient), or evaluated as concave, inspect for standing/pooling water before operations. **(T-3)**. Surveyors will include a remark in block 14 of the AF Form 3822 annotating this requirement and no waiver is required. **(T-2)**.

4.3.3.3.3. For C-17 operations, mission planners will require the RCR a minimum of 24 hours prior to air land operations. **(T-2)**.

4.3.3.4. Semi-Prepared LZ Distress. LZSOs and/or operating aircrews will conduct a surface condition assessment of all LZ features required for operations (e.g., runways, taxiways, aprons, helipads) in accordance with **paragraph 4.3.3**. **(T-3)**. ACs will identify distress that could affect performance/safety of flight/operations, and make employment decisions in accordance with paragraphs **4.2.6.3** and **4.2.6.5**. **(T-2)**. When distresses are present, LZSO/aircrew will utilize Semi-Prepared Airfield Condition Index (SPACI) procedures to assess distresses on unprepared, semi-prepared and non-traditional surfaced airfields/LZs. **(T-2)**. SPACI assessment of surveyed surface type shall be in accordance

with TSPWG M 3-260-03.02-19 and [Table A9.15](#) for surface distress conditions of semi-prep, surface-treatments and macadam surfaces. **(T-0)**. First, define surface distress, (e.g., ruts, potholes, loose aggregate) and individual distress severity level(s). Second, calculate the overall distress severity level for the LZ feature. Finally, report to operating aircrew all “Amber” or “Red” level individual distresses according to the following format: “Type, distress severity level, dimension, location” (e.g., “Runway 23, ruts, “Red”, seven inches deep, 15 feet wide and 500 feet long, on centerline, located 2,500’ from threshold”). Additionally, must report any LZ feature (e.g., runway, taxiway, apron) calculated to an overall “Amber” or “Red” level to operating aircrew. **(T-2)**. When time and operations permit, aircrews and LZSO should report all SPACI assessments to applicable authorities and may upload to Talon Point.

4.3.3.4.1. Distress Severity levels. Distress severity levels are “Green”, “Amber”, or “Red”.

4.3.3.4.2. “Green” severity indicates low risk to aircraft operations. MAJCOMs are responsible for ensuring training LZs are assessed overall as “green” by having an active LZ maintenance program, sustaining “green” and rated strength capability.

4.3.3.4.3. “Amber” severity indicates medium risk to aircraft operations and repairs to the LZ are needed. The potential risk of FOD damage, ruptured tires and other safety of flight issues is increased. Notify the aircrew of the type, distress severity level, dimension and location. **(T-3)**. The aircrew will evaluate the LZ distance or width available and utilize MAJCOM approved tactics, techniques and procedures as required to reduce the risk. **(T-3)**.

4.3.3.4.4. “Red” severity indicates high risk to aircraft operations and requires LZ repair. Avoid or repair identified high-risk areas before subsequent aircraft operations. Notify the aircrew of type, distress severity level, dimension and location. **(T-3)**. The aircrew will evaluate the LZ distance or width available and utilize MAJCOM approved tactics, techniques and procedures as required to reduce the risk. **(T-3)**. When calculating a LZ feature to an overall “Red” level, a MAJCOM waiver shall be required for operations in accordance with [paragraph 1.4](#). **(T-2)**. Training and exercise waivers will be for the applicable operation use only. **(T-2)**. Contingency waivers may be blanketed but will update with each personnel change in waiver authority. **(T-2)**.

4.3.3.5. Rolling Resistant Material (RRM) and Rolling Friction Factor (RFF). RRM is any type of loose or unbound material (dust, till, jet blast erosion, or surface stabilizer failure) on the surface that separates from the solid base and lies on top of the LZ and in ruts. Use assessed RRM values to determine RFF using [Table A9.16](#) Waivers based upon RFF values will be in accordance with [paragraph 1.4](#). **(T-2)**. Loose material (RRM) that correlates to high RFF may require more runway than is available to achieve safe flying speed. Only the C-17 utilizes RFF as the take-off and landing data numerical value representing the loose till on a LZ. All other aircrew will utilize RRM distress depth/SPACI to identify risk and should consider effects RRM may have on aircraft performance and take-off and landing data calculations. **(T-3)**. **NOTE:** Many factors affecting operations, not limited to the following, should be considered when thick RRM/high RFF exist: the AC may elect to reject cargo to ensure sufficient runway is available; mission planners should consider presence of RRM/RFF during the planning phase as it has potential for



insufficient takeoff lengths on projected LZ and/or needed equipment being rejected. **NOTE:** For C-17 operations, mission planners require the RFF a minimum of 24 hours prior to air land operations.

4.3.3.6. C-17 Semi-Prepared Runway Operations Approvals. OG/CC approval is required for semi-prepared runway operations within the CONUS, Alaska and Hawaii. OPCON MAJCOM/Air Component Commander approval is required in all other instances.

4.3.3.7. C-17 Semi-Prepared Runway Operations DCP. Requirements. For semi-prepared LZs other than matted surfaces, qualified/certified/current personnel must complete a DCP assessment within one week of the first landing to verify the LZ meets C-17 requirements. **(T-3)**. The DCP values will be reported back to the OPCON planners. **(T-3)**. **NOTE:** LZSO should perform a DCP analysis following a significant enough rain event on airfields that have soil types susceptible to erosion or material strength reduction. Report any collected controlling reading(s) in the LZ assessment when the estimated WBC is less than the surveyed WBC. **(T-3)**.

4.3.3.8. Aircraft Rescue and Fire Fighting (ARFF). Aircraft MAJCOMs publish ARFF requirements for each aircraft type. An example is Air Mobility Command Instruction (AMCI) 11-208, *Mobility Air Forces Management*. Planners should consult with the aircraft OPCON MAJCOM/Air Component Commander early in the planning cycle to determine and meet ARFF requirements. For exercises and contingency response operations lasting no more than 120 days in a 1-year period, overall USAF ARFF guidance is in accordance with Air Force Pamphlet (AFPAM) 32-2004, *Aircraft Fire Protection for Exercises and Contingency Response Operations*. LZ operations will be in accordance with AFPAM 32-2004 correlating to contingency airfields. **(T-2)**. LZSO must relay observed or reported ARFF status to aircrew as defined in [paragraph 4.8.2.2](#). **(T-2)**.

4.3.3.8.1. Per AFPAM 32-2004, the OPCON MAJCOM/Air Component Commander may exclude ARFF for infrequent flying operations as defined by the following parameters: C-17s will have no more than two takeoffs and two landings within 7 consecutive days, C-130 and smaller aircraft will have no more than four takeoff and four landings within seven consecutive days. **(T-2)**.

4.3.3.8.2. Per AFPAM 32-2004, the aircraft user provides ARFF capability at locations other than established USAF facilities.

4.3.3.9. APZ and exclusion areas for LZs. LZSO and aircrew should assess LZ's APZs and exclusion areas to limit and report any factors that may affect safety or performance of flight. Potential hazards within APZs and exclusion areas are listed in [Table A9.1](#).

#### 4.4. LZ Markings.

4.4.1. Marking Equipment. Virtually any type of lighting or marking system is acceptable if all participating units are briefed and concur with its use. LZs are normally marked with frangible visual LZ marker systems. Daylight operations typically utilize LZ marker panels. Night operations utilize omni-directional visible lighting systems, with a minimum output rating of 15 candela (or equivalent lumens) and strobe lights (if required). Covert infrared lighting systems are standard for night LZ operations. The USAF standard is that aircrew approved for maximum effort operations are also Night Vision Devices (NVD) qualified. During contingency operations, non-NVD aircrew may utilize LZs and overt lights are

required. **NOTE:** Visual marking devices will identify the edge of the surveyed/assessed usable runway as defined in [paragraph 4.4.3](#) unless otherwise coordinated. **(T-2)**. Adjust markings within the surveyed landing surface as needed to ensure a suitable LZ surface and coordinate with using aircrews. **(T-2)**.

4.4.1.1. When anticipating landings at both ends of the LZ, ensure touchdown areas are marked at both ends. **(T-2)**.

4.4.1.2. The LZ markings must be clearly visible to the pilot as early on the approach as possible. **(T-2)**.

4.4.1.3. Added. To prevent damage to aircraft and injury to personnel, all marking lights and associated equipment must be adequately secured to the ground to withstand the rotor-wash, created by the associated aircraft using the marked HLZ.

4.4.1.4. Daytime Markings.

4.4.1.4.1. Orientation and Color. Erect marker panels upright and face toward the aircraft approach to increase visibility to the pilot. The panels should be orange (Fluorescent Orange, Army Shade 230), cerise (Fluorescent Red, Army Shade 229), or other similar color clearly visible to increase the pilot's ability to see them.

4.4.1.4.2. Materials and Size. Construct temporary panels of fabric, wood, or other materials determined to be suitable by the LZSO. Panel faces should be at least 66 inches wide and 17 inches tall. Manufactured markers or expedient objects used as markers and any supports will be frangible to avoid excessive damage if struck by an aircraft. **(T-2)**.

4.4.1.5. Mark loading and taxi areas as determined during mission planning or report deviations to markings. **(T-2)**. For night operations, place suitable blue lights 500 feet apart on the straight portions or report deviations to markings. **(T-2)**. If requested, reflectors may be placed halfway between the blue lights. Reduce light spacing to 75 feet on curves and at corners or intersections or report deviations to markings. **(T-2)**.

4.4.2. Terminal NAVAIDS and Beacons. Special tactics and CRG units can deploy NAVAIDS as directed by the Air Component Commander. Modify the standard NAVAID and/or beacon procedures listed in paragraphs [4.4.2.1](#) and [4.2.2.2](#) as required for the tactical environment. NAVAIDS/beacons on LZs should be offset to the edge of the runway to ensure safe landing and taxiing vertical obstacle clearance requirements are met.

4.4.2.1. NAVAID. When used for instrument procedures, recommended placement is 150 feet right of runway edge, abeam the first set of approach threshold lights (panels) in an area free of excessive aircraft, vehicle and troop movements.

4.4.2.2. Beacons. Ensure to brief aircrews on beacon placement. For Airfield Marking Pattern (AMP)-1 through AMP-3 landings, place approach threshold beacon 150 feet left of the edge of runway abeam the first set of steady lights (panels). Place departure threshold beacon 150 feet left of the edge of runway abeam departure threshold set of steady lights (panels) or flashing strobe. If only one beacon is used, place at approach. Use beacons as depicted in paragraph [4.4.3.1](#) and [4.4.3.2](#) for AMP-1 and [paragraph 4.4.3.4](#) for AMP-3.

4.4.3. Airfield Marking Patterns (AMP). There are four standard types of airfield marking patterns, designated AMP-1 through AMP-4. When required, place panels for AMPs 4'-10'

from the surveyed edge of the runway and place lights for AMPs at 5'-7' from the surveyed edge. (T-2). Ensure all markings are visible for using aircrew. Adjust markings within the surveyed landing surface as needed to ensure a suitable LZ surface and coordinate using aircrews. (T-2).

4.4.3.1. AMP-1. AMP-1 is normally used to support day or night VMC airlift missions. See Figure 4.3 for day markings and Figure 4.4 for night/instrument markings. These markings also implement STANAG 3570 and Air and Space Interoperability Council requirements. When using the AMP-1 pattern, aircrew mission planners and ACs are authorized to reduce panel markings for well-defined runways during non-instrument approach VMC operations. As a minimum, mark the touchdown zone and the end of the usable runway (not including overrun). (T-2). Coordinate reduced marking with all participating elements. (T-2).

Figure 4.3. AMP-1 Day.

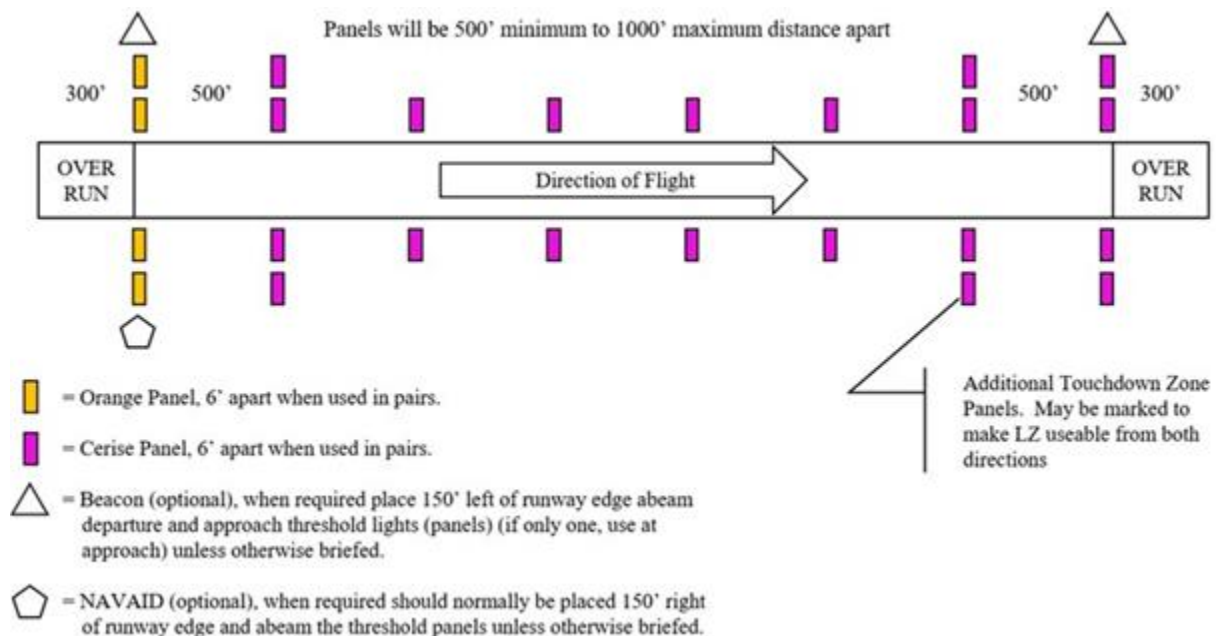

4.4.3.2. AMP-1 (Instrument Approach). Instrument approaches for contingency LZs require special configuration. Use this configuration to support day or night tactical airlift missions during times of reduced visibility. Aircrew mission planners must not be authorized to reduce or eliminate panels, lights, or electronic navigational aids during limited visibility operations. (T-1). **NOTE:** Instrument approaches to LZs can be developed as MAJCOM certified procedures (See AFMAN 11-202V3). Complete a Federal Aviation Administration (FAA) flight check (instrument approaches) or military aircraft fly-ability check prior to using the LZ/airfield for sustained operations (T-1).

Figure 4.4. AMP-1, Night/Instrument Approach.

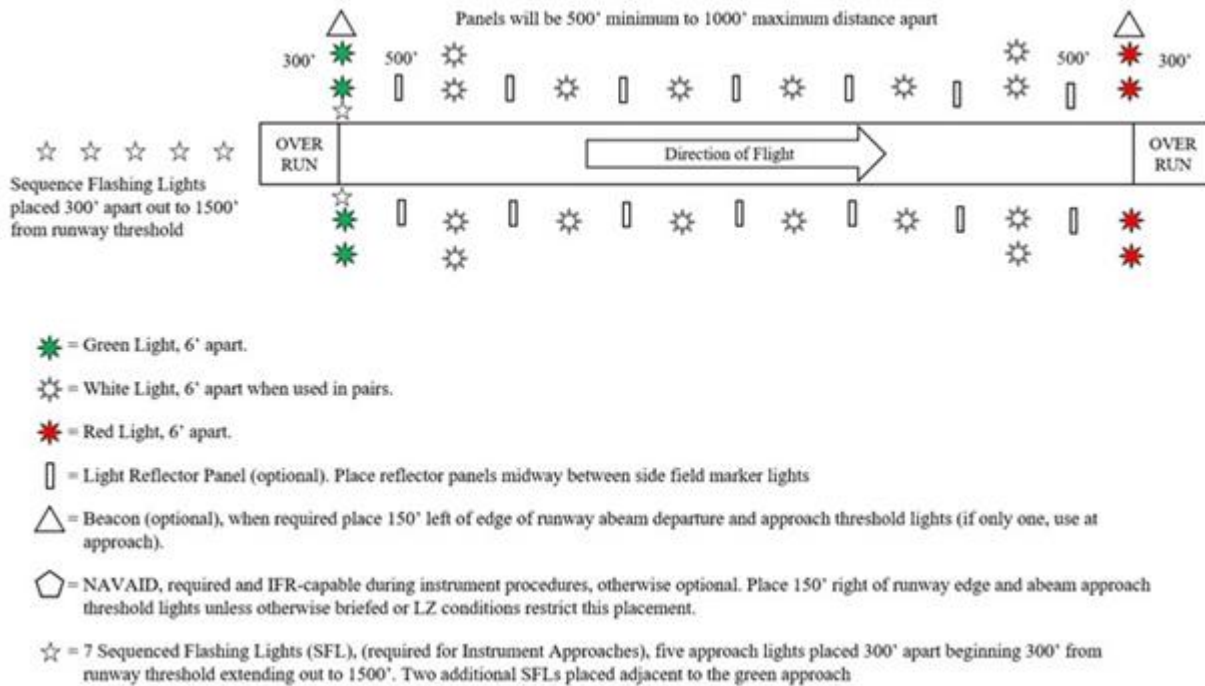

4.4.3.3. AMP-2. Use AMP-2 to support day or night tactical airlift requirements. AMP-2 requires fewer panels or lights than AMP-1. Overt or covert lighting may be used. See [Figure 4.5](#) and [Figure 4.6](#).

Figure 4.5. AMP-2, Day.

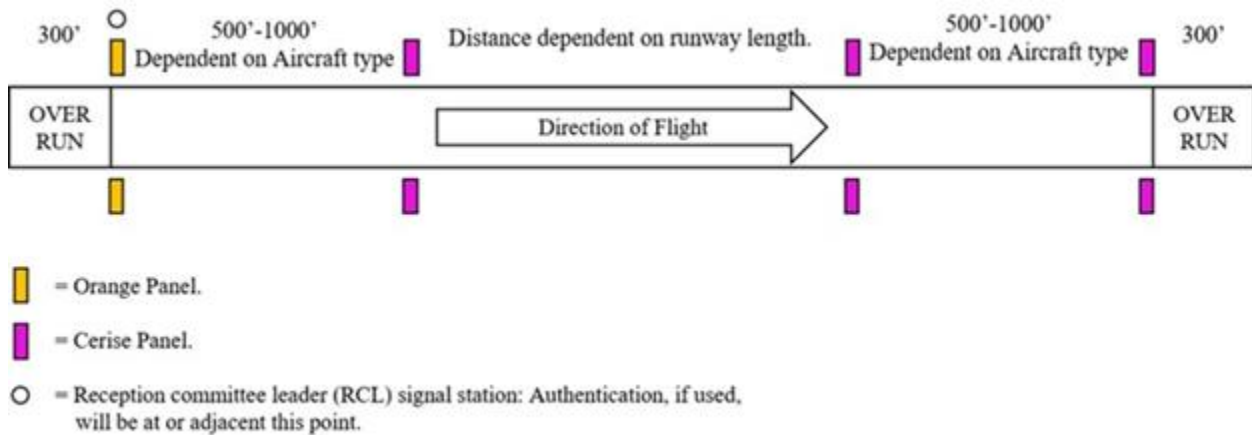
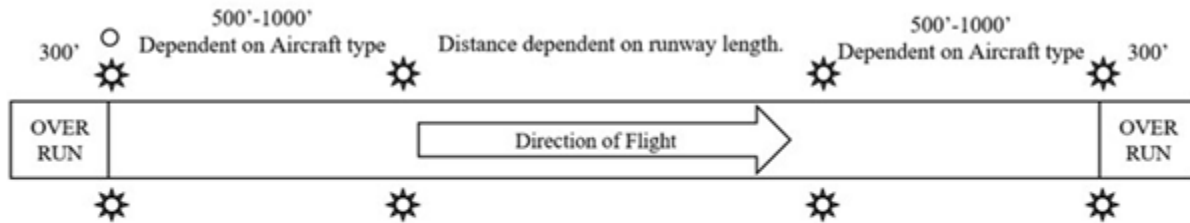

Figure 4.6. AMP-2 Night.



- ☀ = Field Marker Light: May be overt or covert.
- = Reception committee leader (RCL) signal station: Authentication, if used, will be at or adjacent this point.

4.4.3.4. AMP-3. AMP-3 further reduces the number of panels/lights used to support day or night tactical airlift requirements. Use overt or covert lighting. The “Box and One” is for runway identification only and the standard box length should be 500 feet. The box length may be 500' or 1000' depending on the tactical situation and the box length may be 200' for LTFW aircraft. If the box length is not 500', it is mandatory the LZ controlling authority ensures all participating aircraft are notified of the nonstandard box length. (T-2). See [Figure 4.7](#) for day markings and [Figure 4.8](#) for night markings.

Figure 4.7. AMP-3, Day.

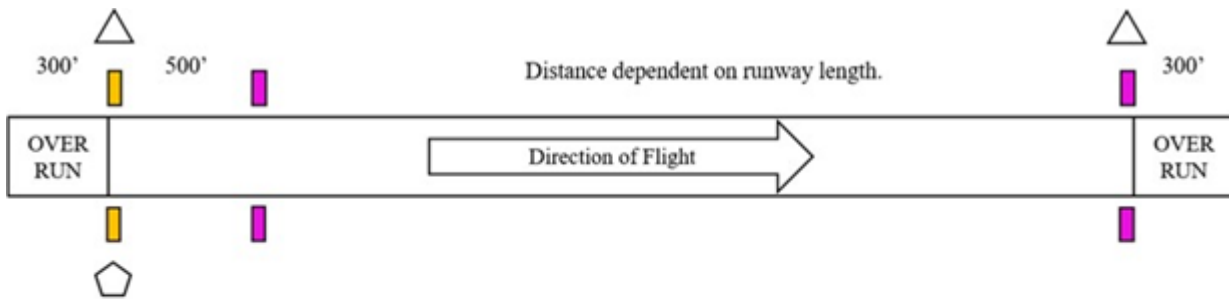

- = Orange Panel.
- = Cerise Panel.
- △ = Beacon (optional), when required place 150' left of edge of runway abeam departure and approach threshold lights (if only one, use at approach)
- ⬠ = NAVAID (optional) used during instrument procedures, place 150' right of runway edge and abeam the approach threshold lights unless otherwise briefed or airfield conditions restrict this placement.

NOTE: LTFW aircraft may use a 200' box length. See Paragraph 4.4.3.4.

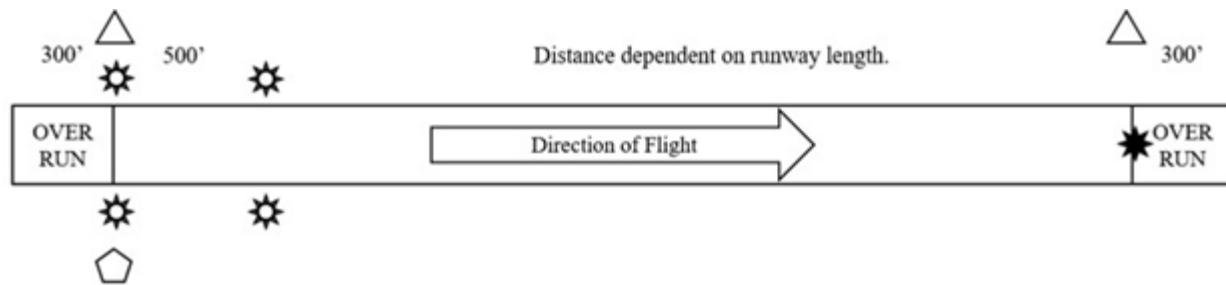
**Figure 4.8. AMP-3, Night.**

☀ = Field Marker Light: May be overt or covert.

★ = Strobe Light: Placed on centerline at the end of the usable runway, overrun, or at a point along the runway centerline that permits safe landing and takeoff (may be overt or covert). May be placed in a different location or unused if pre-coordinated

△ = Beacon (optional), when required place 150' left of edge of runway abeam departure and approach threshold lights (if only one, use at approach)

⬠ = NAVAID (optional) used during instrument procedures, place 150' right of runway edge and abeam the approach threshold lights unless otherwise briefed or airfield conditions restrict this placement.

**NOTE:** LTFW aircraft may use a 200' box length. See Paragraph 4.4.3.4.

4.4.3.5. AMP-4. No markings are used for AMP-4. Unmarked LZs are referred to as AMP-4 or as AMP-4 operations.

**4.5. Unmarked LZ.** Unmarked LZs are referred to as AMP-4 or as AMP-4 operations as listed in [paragraph 4.4.3.5](#) Aircrew must be approved and trained by the MAJCOM prior to conducting unmarked LZ operations. **(T-2)**. MAJCOMs may have different procedures for day and night operations. Night operations may be further distinguished by unaided (no NVD or onboard equipment), NVD, aircraft equipment aided and lunar illumination requirements.

#### **4.6. LZ Communications.**

4.6.1. Radio Procedures. Radio communication procedures will be in accordance with MAJCOM-approved LZSO training. **(T-2)**.

4.6.2. Emergency Signals. Standard ATC light signals are normally used if radio communications are not established. Signal a go around by using either red flares, a red-light beam aimed directly at the pilot, or a radio call to the pilot. See [Table 4.3f](#). **NOTE:** Coordinate and thoroughly brief emergency signals. **(T-2)**. NVG equipped crews may be unable to discern colored lights and any light signal pointed at the aircraft may blind the aircrew.



**Table 4.3. Standard Air Traffic Control Light Signals.**

SIGNAL	AIRCRAFT ON GROUND	AIRCRAFT IN AIR
Steady Green	Cleared for Takeoff	Clear to Land
Flashing Green	Clear to Taxi	Return for Landing
Steady Red	Stop	Give way to other aircraft and continue circling
Flashing Red	Taxi Clear of Runway	Field unsafe-Do not land
Flashing White	Return to starting point	N/A
Alternating Red/Green	Use extreme caution	Use extreme caution

**4.7. LZ Control Point Location.** The LZSO/LZC locates the control point after considering pertinent factors such as security, threat, runway in use and view of the airfield and surrounding airspace. Separation of aircraft and the ability to detect hazards on or near the operating area supersede other concerns.

#### **4.8. LZ Personnel.**

4.8.1. **LZSO.** LZ operations require a LZSO. A LZC may also be required for operations involving multiple aircraft in the terminal area, for airspace de-confliction, and/or movement control on the LZ in accordance with [paragraph 4.8.3](#) The LZSO shall be trained, certified and current in accordance with [paragraph 4.9](#) The LZSO is normally a 5, 7 or 9 skill level CCT/STO, or an AMLO. 7 or 9 level AFSPECWAR personnel, or personnel in specialties related to aviation/airfield operation, may be certified as LZSOs. AMC Mobility Support Operations (AMC/A3M) may also authorize CR personnel with 7 or 9 skill levels not in specialties related to aviation or airfield operations to be certified as LZSOs. **(T-2). NOTE:** Special Operations Group/CCs (or COMAFSOF) may waive the LZSO requirement for a single aircraft during infil and exfil for contingency operations.

4.8.1.1. **USAF Weapons School Personnel.** USAFWS Weapons Officer cadre and specified civilian contract personnel supporting USAFWS Weapons Officer training may perform LZSO duties at all approved CONUS LZs in support of USAFWS Weapons Officer training syllabi.

4.8.1.2. **Air Traffic Controllers and Airfield Operations Officers.** Air traffic controllers and airfield operations officers require LZSO certification to conduct LZC duties in accordance with [paragraph 4.8.3.1](#) Normally, both a separate LZSO and a LZC are required for operations; however, AMC/A3M may authorize air traffic controllers or airfield operations officers to combine LZSO/LZC duties for contingencies or as part of CRG operations in accordance with [paragraph 4.8.3.4](#).

4.8.1.3. **DoD Civilian and Contract Personnel.** DoD civilian and contract personnel may perform LZSO functions provided they were previously certified, their statement of work requires those duties, they meet continuation requirements outlined in [paragraph 4.9](#), and are certified by the current unit commander. **NOTE:** ANG/AFR Dual Status Technicians may perform these duties in a technician status.



4.8.1.4. Lead MAJCOM Validated sister service and partner nation LZSO Personnel. Marine Aviation Weapons and Tactics Squadron One (MAWTS-1) conducts AFSOC validated sister service LZSO qualification program for the United States Marine Corps (USMC). Lead MAJCOM validated partner nation LZSO qualification program for the RAAF is conducted by RAAF CCT. RAAF CCT may be certified to conduct LZSO in accordance with AFSOC/A3T validated AUS-LMP *Assault Zone Reconnaissance Course* and this manual. Additional sister service or partner nation LZSO training programs not identified in this manual may seek certification by way of a Memorandum of Agreement until inclusion.

4.8.1.5. Other DoD LZSO Personnel for contingency operations. A certified LZSO may train other DoD personnel (with Air Component Commander or COMAFSOF approval) to perform LZSO duties in accordance with [paragraph 4.9](#) using MAJCOM-approved lesson plans when required for contingency operations. Conduct training, certification and continuation training of personnel in accordance with [paragraph 4.9](#).

4.8.1.6. LZSO for Unprepared LZ or in Hostile Environments. CCT/ STO, RAAF CCT and MAWTS-1 personnel certified LZSOs are authorized to perform duties in hostile environments. AFSOC Special Warfare personnel certified LZSOs may be authorized by unit commander to perform duties in hostile environments. Airfield Operations Career fields (13M/1C1/1C7), or AMLO personnel certified LZSOs may be authorized to perform duties in hostile environments with MAJCOM/A3 or Air Component Commander Approval.

#### 4.8.2. LZSO Responsibilities. (For operations on LZs and rated airfields).

4.8.2.1. The LZSO represents the appropriate commander as provided in mission directives.

4.8.2.2. If ARFF is present, the ARFF relays status and capability at the LZ prior to the beginning air land operations. The LZSO ensures continuous contact with ARFF is maintained and reports to aircraft when ARFF coverage is not present at the LZ.

4.8.2.3. The LZSO maintains close liaison with the using unit commander, or designated representative, during joint operations.

4.8.2.4. The LZSO supervises and directs movement of all personnel and vehicles on the LZ, taxiways and within the exclusion area. If applicable, the LZSO coordinates with ground mission commander to minimize and control troop and vehicle movement.

4.8.2.5. The LZSO observes and evaluates all factors that may adversely affect the safety and efficiency of the operation.

4.8.2.6. The LZSO acquires and utilizes the current applicable zone surveys to assess all observed obstacles, hazards, or threats not documented on the surveys which may affect operations, and reports them to ground mission and airlift mission commanders. The LZSO maintains Talon Point accounts for access to current zone surveys, and to view/submit assessments.

4.8.2.7. The LZSO assesses, monitors and reports surface distresses when they exist.

4.8.2.8. The LZSO assesses, monitors and reports wet and/or dry surface conditions. When the LZ or airfield has experienced rainfall or surface distresses (e.g., excessive loose

aggregate, layer failure or erosion), the LZSO provides tactical RCR/braking action (ICAO) estimates or pilot reports in accordance with [paragraph 4.3.3.3](#) The LZSO determines when semi-prepared feature(s) soil type/condition and amount of rainfall/moisture require Assessment Cone Penetrometer (ACP) or Dynamic Cone Penetrometer (DCP) readings in accordance with [paragraph 4.3.1.1](#) When applicable, the LZSO conducts readings for assessment and reports any controlling reading(s) with estimated WBC less than surveyed. Additional requirements for C-17 apply in accordance with [paragraph 4.3.3.7](#).

4.8.2.9. The LZSO monitors the conditions of the landing, taxi, and parking areas and ensures the runway is free of obstacles before providing landing or takeoff advisories to aircraft operating at the LZ.

4.8.2.10. The LZSO ensures LZ markings (to include beacons and NAVAIDs if utilized) are correctly placed, secured and operating.

4.8.2.11. The LZSO manages, employs, monitors and may assist with ground handling, marshaling of aircraft and wing walkers when required. The LZSO also enforces safe aircraft parking setback from movement areas.

4.8.2.12. The LZSO evaluates and reports meteorological phenomena and surface wind. Surface wind is normally measured using an anemometer or other calibrated wind-measuring device. Then LZSO reports wind direction in magnetic degrees and wind speed in knots. The direction reported is the direction the wind is coming from. Use [Attachment 2, Table A2.2](#), Summary of Wind Observing Standards, to determine and report wind data for assault zone operations in accordance with the wind chapter of AFMAN 15-111, *Surface Weather Observations*. Each aircraft type has different crosswind and tailwind limitations. Successful LZ operations may depend on referring to climatology data to determine optimum LZ orientation and the predominant landing runway direction for a given season. Crosswind and tailwind limitations may make a LZ unusable if there are obstructions on the wind favorable final course. Ground units should include planners from the flying unit early in the planning process to address aircraft wind limitations. **NOTE:** Wind limitations are based on available aircraft control surface authority, and stall characteristics are based on high or low wing and rudder size and placement. Due to limitations being based on the physical construction of the aircraft, wind limitations are rarely waived.

4.8.2.13. The LZSO ensures the dissemination of available estimated altimeter settings.

4.8.2.14. The LZSO formulates minimum safe altitudes and monitors the de-confliction of artillery and close air support operations.

4.8.2.15. The LZSO closes the LZ for air operations if conditions are unsafe for landings and relays cancellation of operations to aircrew and all appropriate agencies. The LZSO re-opens the LZ when safe operations can resume and notifies appropriate agencies. **NOTE:** Aircrew may choose to conduct operations at their own risk.

4.8.2.16. If a LZC is present at the LZ, the LZSO maintains contact with the LZC during the operation and advises the LZC if conditions are unsafe for landing operations.

4.8.2.17. The LZSO coordinates, establishes and enforces runway crossing points.

4.8.2.18. For C-17 Semi-Prepared Runway Operations, the LZSO determines the RFF, RCR, or ICAO braking action in accordance with paragraphs 4.3.3.5 or 4.3.3.3 and reports the RFF, RCR, or ICAO braking action to the aircrew prior to taxi, departure and arrival. After each C-17 departure, or anytime the LZ team notices a discernable deterioration of the LZ surface, the LZSO will re-determine values. **(T-3)**. If it is not feasible to determine a new RFF, the LZSO must hold C-17 until RFF can be evaluated. **(T-3)**.

4.8.2.19. LZSOs should know how to make inputs to special instructions and airspace control orders, as well as access the airspace control plan if they have proper clearance.

4.8.3. LZC. The LZC's primary function is to provide ATC services. A LZC is not required if ATC services are not required to support planned LZ operations. The LZC shall be trained, certified and current in accordance with **paragraph 4.9** capable of performing unilateral or joint ATC duties. **(T-2)**. The LZC is normally a 7 or 9 level CCT/STO. The LZC may also be a 7 or 9 level USAF air traffic controller with control tower operator credentials, a 7 or 9 level CR air traffic controller, or a 7 or 9 level airfield operations officer with control tower operator credentials. Additionally, all personnel above at 3 or 5 level may conduct LZC duties but shall not perform duties unsupervised. **(T-1)**. Finally, the LZC may be a Marine Aviation Weapons and Tactics Squadron-1 (MAWTS-1) trained Marine Air Traffic Control Mobile Team Leader with control tower operator credentials. RAAF CCT are not validated to perform LZC duties for USAF.

4.8.3.1. USAF and USMC Air Traffic Controllers and Airfield Operations Officers. In addition to requirements for LZC identified above, USAF and MAWTS-1 Air Traffic Controllers and Airfield Operations Officer personnel must also be LZSO certified in accordance with paragraphs 4.8 and 4.9 to perform LZC duties. **(T-1)**. For operations at CONUS/OCONUS main operating bases with co-located paved assault LZs, see AFMAN 13-204V3, *Air Traffic Control*, for additional guidelines.

4.8.3.2. DoD Civilian and Contract Personnel. Current and previously LZC certified CCT/STOs and USAF air traffic controllers that are DoD civilians and contractors may perform LZC functions provided their statement of work requires those duties, they pass a flying class II physical and they meet LZSO and LZC continuation training in accordance with **paragraph 4.9.3**, and are certified by the current unit commander. **(T-2)**. **NOTE:** ANG/AFR Dual Status Technicians may perform these duties in a technician status.

4.8.3.3. Hostile Environments. CCT/STO and MAWTS-1 ATC trained MTT personnel certified LZC provide ATC plans and services for operations to all assault zones in hostile environments. Airfield operations personnel in accordance with **paragraph 4.8.3** may be certified to operate as LZC in hostile environments with MAJCOM/A3 or Air Component Commander approval.

4.8.3.4. Combined LZSO/LZC Duties. Current 7/9 level CCT/STOs, LZSO certified DoD Air Traffic Controllers and previously certified 7/9 CCT/STOs that are DoD civilians and contractors may combine LZC/LZSO functions during VFR operations.

4.8.3.5. LZ Controller Crew Rest. To enhance flight safety, LZC duty hours for conventional air traffic controllers shall be in accordance with AFMAN 13-204V3.

4.8.3.6. LZ Controller Responsibilities. The LZC provides ATC services. When combining LZC and LZSO functions, in accordance with [paragraph 4.8.2.3](#), both LZC and LZSO responsibilities and requirements must be met. **(T-3)**.

#### 4.8.4. LZSO/LZC NVD Use.

4.8.4.1. LZCs are authorized to use NVDs while controlling aircraft in terminal areas. LZSOs are authorized to use NVDs to conduct duties.

4.8.4.2. Special Warfare personnel, aircrew and LZSOs are authorized to use NVDs for marshalling of aircraft in terminal areas if trained and certified in the procedure.

**4.9. LZ Personnel Qualification Training, Certification and Continuation Training.** All personnel authorized to conduct LZSO in accordance with [paragraph 4.8.1](#) will accomplish qualification training, certification and continuation training specified in this paragraph unless specified by AFSC-specific AFI, AFMAN, or Career Field Education and Training Plan (CFETP) or validated Joint Service equivalent. **(T-2)**. All personnel authorized to conduct LZC in accordance with [paragraph 4.8.3](#) will accomplish initial qualification training and continuation training specified by AFSC-specific AFI, AFMAN, CFETP, AFSOC SOI, or validated Joint Service equivalent. **(T-2)**. LZC will be certified by their unit commander. **(T-2)**.

4.9.1. LZ Safety Officer SOI, Lesson Plan and Course Certification. AFSOC shall provide a validated LZSO SOI and review it yearly for changes/updates. AFSOC is designated as the lead MAJCOM. **(T-1)**. Other MAJCOMs and Joint Service or partner nations who have a need for LZSOs in accordance with [paragraph 4.8](#) shall develop LZSO lesson plans in accordance with the AFSOC LZSO SOI. MAJCOMs shall submit lesson plans to AFSOC/A3T for review and approval or disapproval within 30 days. MAJCOMs (and AFSOC Wing or Group) shall provide an approved lesson plan for LZSO qualification, will review the lesson plan yearly in accordance with AFSOC SOI and submit changes to AFSOC/A3T. **(T-1)**. AFSOC/A3T will maintain a listing of all approved lesson plans and may maintain approved plans in Talon Point. **(T-1)**. Receipt of the LZSO course certification will occur after AFSOC Standards and Evaluations (AFSOC/A3V) inspects the initial course being taught with an approved lesson plan and course passes certification evaluation. **(T-1)**. Course certification is good for 3 years. Certified courses will schedule a course reevaluation prior to the end of the 3-year certification. **(T-1)**. Updates, changes and critical FCIFs will be incorporated into all lesson plans and/or courses, with new lesson plans being provided to AFSOC/A3T for review. **(T-1)**. Unless determined not in compliance with SOI, certification for lesson plans and courses will remain effective. **(T-1)**.

4.9.2. LZ Safety Officer Certification. Unit commanders shall certify all qualified personnel specified in [paragraph 4.8.1](#) who have successfully completed validated LZSO lesson plan qualification training, course, or CFETP task requirements (CCT/STO). **(T-2)**. Unit commanders must ensure personnel are capable of performing all LZSO duties and responsibilities. **(T-2)**. Unit commanders will document certification/de-certification. **(T-2)**. At a minimum, the unit tactics, group tactics office or equivalent office will maintain a current list of personnel certified. **(T-0)**. For USAF operations, MAWTS-1 and RAAF CCT LZSO certification is contingent upon documented certification submitted to AFSOC/A3T. A current and certified LZSO, with a minimum of 12 months maintaining currency, shall conduct LZSO instruction. **(T-2)**. MAJCOMs may identify additional requirements for LZSO instructors.

4.9.3. LZ Safety Officer Currency Requirements. All authorized LZSO personnel will conduct a LZSO academic review and LZSO event once every 12 months at a minimum. **(T-2)**. Commanders must ensure certified LZSOs are current in accordance with [paragraph 4.9.3](#) prior to LZSO conducting operations unsupervised. **(T-2)**.

4.9.3.1. LZSO Academic Review. Academic review is the review of respective certified LZSOs lesson plan.

4.9.3.2. LZSO Event. A LZSO event, by definition, includes pre-mission planning, survey analysis, day or night assessment, ground to air communications, establishment/markings emplacement (day or night), required notifications and LZSO airfield management. **NOTE:** Do not use LZ assessed as “closed” for LZSOs events. Operations with live aircraft are required to determine if LZSO can appropriately monitor LZ for safe operations and provide appropriate advisories.

4.9.3.3. Currency requirements for USAF CCT/STO and previously certified USAF CCT/STO DoD civilians and contractors is in accordance with the CFETP 1Z2X1, *Combat Control* and CCT/STO continuation training guidance.

4.9.3.4. Air Mobility Liaison Officers (AMLO). Continuation training, re-currency and recertification requirements for AMLO are completed in accordance with AFMAN 13-106.

4.9.3.5. All Other Authorized LZSO Personnel. All other authorized LZSO personnel will conduct a LZSO academic review (as defined in approved lesson plans) and LZSO event, day or night, once every 12 months to maintain currency in LZSO certification. **(T-2)**. Personnel who fail to accomplish a LZSO academic review and LZSO event once every 12 months will not perform LZSO duties unless directly supervised by a current and certified LZSO. **(T-2)**. Personnel who fail to accomplish a LZSO academic review and LZSO event once every 18 months will be de-certified and not perform LZSO duties until re-trained and re-certified. **(T-2)**.

4.9.3.6. Lead MAJCOM Validated Sister Service and Partner Nation LZSO Personnel. Currency requirements for MAWTS-1 trained personnel and RAAF CCT personnel is in accordance with [paragraph 4.9.3.5](#) or AFSOC validated sister service and partner nation LZSO training and standards/evaluation guidance.

**4.10. LZ Surveyors.** CCT/STO, CR airfield assessment team personnel, AFCEC engineers, previously CCT/STO LZ survey certified DoD civilians and contractors, designated AFSPECWAR personnel serving in special tactics units, AMLOs and lead MAJCOM validated sister service/partner nation personnel shall be authorized to conduct LZ surveys and complete the AF Form 3822, ([Attachment 5](#)). **(T-2)**. All personnel will accomplish qualification, certification in accordance with [paragraph 4.10.6 – 4.10.8](#). **(T-2)**. The LZ surveyor will also conduct tasks in accordance with [paragraph 2.3.2](#) and perform the ground portion of the LZ survey (e.g., obtain physical or digital maps and elevations, collect data based on LZ minimums, create diagrams and report results on the AF Form 3822, (or tactical LZ Survey-CCT/STO only). **(T-2)**.

4.10.1. CCT and STO. Personnel must be qualified, certified and current in accordance with AFSC 1Z2X1, Combat Control CFETP and CCT/STO continuation training requirements on LZ surveys and tactical LZ surveys. **(T-3)**. CCT/STO are trained, equipped and certified to conduct surveys and assessments on unimproved, semi-prepared and prepared LZs in hostile and semi-permissive environments.



4.10.2. CR, AMLO and AFSPECWAR LZ Survey Certified Personnel. Train and qualify personnel using a formal, approved LZ survey lesson plan in accordance with [paragraph 4.10.6](#). (T-2). CR LZ surveyor certified personnel shall be at a minimum, a current AFCEC-trained engineer certified to conduct surveys of prepared (paved) and semi-prepared LZs for sustained airfield operations in accordance with [paragraph 4.10.4](#). (T-2). AMC/A3M must authorize AMLO personnel to be LZ surveyor qualified, unit certified, and will appropriately equip authorized personnel to perform the capability.

4.10.3. DoD Civilian or Government Contract Personnel. Current and previously certified CCT/STO DoD civilians and contractors may perform LZ Surveys provided their statement of work requires those duties. Personnel must have been initially certified LZ surveyors, re-gain currency in accordance with CCT/STO continuation training requirements on LZ surveys and tactical LZ surveys, and are certified by the current unit commander. (T-2).

4.10.4. Airfield Pavement Evaluators. A valid Airfield Pavement Evaluation requires personnel to be AFCEC Contingency Airfield Pavement Evaluation Course trained and certified and current in accordance with the course guidance. (T-2). Specific currency, retraining, recertification requirements for all AFSC graduates of the AFCEC Contingency Airfield Pavement Evaluation Course shall be in accordance with course guidance. (T-2). If designated to survey LZs, train and qualify AFCEC engineers using a formal LZ survey lesson plan that is approved in accordance with [paragraph 4.10.6](#). (T-2).

4.10.5. Lead MAJCOM Validated Sister Service and Partner Nation Personnel. Marine Aviation Weapons and Tactics Squadron One (MAWTS-1) conducts the lead MAJCOM validated sister service LZ survey training program for the USMC. Graduates of this surveyor program are certified to conduct LZ Surveys in accordance with this manual. Lead MAJCOM validated partner nation LZ survey qualification program for the RAAF is conducted by RAAF CCT. RAAF CCT may be certified to conduct LZ survey in accordance with AFSOC/A3T validated *AUS-LMP Assault Zone Reconnaissance Course* and this manual. Additional sister service or partner nation LZSO training programs not identified in this manual may seek certification by way of a Memorandum of Agreement until inclusion in this manual.

4.10.6. LZ Surveyor POI, Lesson Plan and Course Certification. AFSOC shall provide a validated LZ surveyor SOI and review it yearly for changes/updates. (T-1). AFSOC is designated as the lead MAJCOM. (T-1). Other MAJCOMs and Joint Service or partner nations who have a need for LZ surveyors in accordance with [paragraph 4.8](#) shall develop a LZ surveyor lesson plan in accordance with the AFSOC LZ surveyor SOI. MAJCOMs shall submit lesson plans to AFSOC/A3T for review and approval or disapproval within 30 days. (T-1). MAJCOMs (and AFSOC Wing or Group) shall provide an approved lesson plan for LZ surveyor qualification, will review lesson plans annually using AFSOC SOI guidance and submit changes to AFSOC/A3T. (T-1). AFSOC/A3T will maintain a listing of all approved lesson plans and may maintain approved plans in Talon Point. (T-1). LZ surveyor course certification will be attained after AFSOC/A3V inspects the initial course being taught with an approved lesson plan and course passes certification evaluation. (T-1). Course certification is good for 3 years. Each certified course will schedule a course reevaluation prior to the end of the 3-year certification. (T-1). Incorporate updates/changes and critical FCIFs into all lesson plans/courses, with new lesson plans being provided to AFSOC/A3T for review. (T-1). Unless determined not in compliance with SOI, certification for lesson plan and courses will remain effective. (T-1).

4.10.7. LZ Surveyor Certification. Unit commanders shall certify all qualified personnel specified in paragraph 4.10.1 – 4.10.5 who have successfully completed validated LZ survey lesson plan qualification training, course, or CFETP task requirements (CCT/STO). (T-2). Unit commanders must ensure personnel are capable of performing all LZ survey duties and responsibilities. (T-2). Unit commanders will document certification and de-certification. (T-2). At a minimum, the unit tactics, group tactics office or equivalent office will maintain a current list of personnel certified. (T-0). For USAF operations, MAWTS-1 and RAAF CCT LZ survey certification is contingent upon documented certification submitted to AFSOC/A3T.

4.10.8. LZ Surveyors Continuation Training. All other authorized LZ survey personnel will conduct a LZ survey academic review and LZ survey event, (as defined approved lesson plans), once every 12 months to maintain currency in LZ survey certification. (T-2). Personnel who fail to accomplish both every 12 months will not perform LZ survey duties unless directly supervised by a current and certified LZ surveyor. (T-2). Personnel who fail to accomplish both every 18 months will be de-certified and not perform LZ survey duties until re-trained and re-certified. (T-2). **Exception:** CCT/STO continuation training is in accordance with paragraph 4.10.1.

**4.11. Quality Check.** The quality check authority is a certified LZ surveyor other than the original surveyor. **NOTE:** Prior to safety of flight submission, submit all paved and nontraditional surfaced LZ surveys to be reviewed in accordance with paragraph 4.3.1.2.4. (T-2).

**4.12. Safety of Flight Review.** LZ surveys require a safety of flight review and a signature certifying the review has been completed. The review requires a quality control of both the ground and flight portions of the LZ survey. Additionally, analysis will be conducted using the safety of flight review criteria plus additional risk of aircrew/aircraft information. (T-2).

4.12.1. Safety of Flight Reviewers. The Group/CC or O-6 equivalent must document personnel authorized to perform safety of flight reviews in writing. (T-2). Personnel must have documented USAF aircrew semi-prepared/unprepared LZ experience as either a rated officer or as a career aviator. (T-2). Group/CCs or O-6 equivalents are recommended to utilize current/previous rated officer instructors but are not prohibited from using other personnel as long as all requirements are met. In the event the LZ is surveyed by personnel in the same unit that conducts safety of flight review, a different person will conduct the safety of flight review. (T-2).

4.12.1.1. For Air Component Commanders, COMAFSOF or O-6 equivalent, the designated safety of flight reviewer may perform safety of flight reviews on LZ surveys. If an asset that is not OPCON to that Air Component Commander is using the survey, the Air Component Commander will identify the survey to either the OPCON MAJCOM/Air Component Commander/AMD for safety of flight review and authority of approval/disapproval/rejection. (T-0). **NOTE:** If an AOC/AMD approval is required for contingency operations, the tactics office in the AOC/AMD may complete the safety of flight. The AOC/AMD tactics office will identify their published surveys to AMC. (T-2).

4.12.1.2. MAJCOMs may accept and use LZ surveys reviewed and signed by other MAJCOMs and OPCON authorities.



4.12.1.3. For AMC OPCON assets to utilize a LZ survey, AMC requires that surveys not reviewed by a regional tactics office receive an additional AMC review prior to use by AMC OPCON aircraft.

4.12.1.4. ANG units flying under Title 32 are highly encouraged to only utilize LZ surveys reviewed and approved by RegAF MAJCOMs. The gaining RegAF MAJCOM will convene the Class A accident investigation boards concerning ANG operated Mobility AFs airframes, even when the ANG is operating in Title 32 status.

4.12.2. Safety of Flight Review Criteria. If the safety of flight reviewer discovers fundamental errors on the survey they may contact the surveyor to obtain the information, or the safety of flight reviewer may elect to reject the survey and return it to the surveyor for correction.

4.12.2.1. Use a 1:50,000-scale chart and satellite imagery (if available) or MAJCOM directed mission planning software for the objective area and at least a 1:250,000-scale chart for the run-in and escape.

4.12.2.2. Document all required information on the AF Form 3822. Refer to [Attachment 5](#) for items the surveyor could annotate on the AF Form 3822. Examples are: Terrain on extended final, towers and airspace. Add any required information to the AF Form 3822 or consider rejecting the survey to the surveyor to add the required information to both block 13, LZ diagram and block 14, remarks, within the LZ Survey.

4.12.2.3. Evaluate the LZ route of flight to determine if there are obstructions or over-flight restrictions that may affect an aircraft's ability to reach a stabilized point. Evaluation of terrain/obstructions should include service ceiling and climb. Evaluate a four engine fixed wing aircraft for three-engine climb out and evaluate a two engine fixed wing aircraft for single-engine climb out. **(T-2)**.

4.12.2.4. Evaluate surveyed aprons, taxiways and runways for safe landing and ground operations using reported LZ minimum WBC, geometrics and vertical obstruction clearances. The ASRR contains AMC criteria in the *Suitability Policy and Procedures* section. **Caution:** safety of flight reviewers use the performance criteria for all aircraft or the most restrictive aircraft assigned/apportioned to their OPCON authority. Additional users of the LZ survey must ensure the LZ air and ground portions are suitable for their aircraft performance. **(T-0)**. **NOTE:** Operators of rotary-wing and single engine fixed wing engine aircraft will evaluate the availability of suitable emergency landing surfaces as part of the initial LZ selection and risk evaluation process. **(T-2)**.

4.12.2.5. The AF Form 3822 documents the conditions that existed at the time of the survey's completion and may not account for changes to the LZ due to climatic condition, seasonal topography, or man-made adjustments to the previously surveyed area. Prior to commencing operations, confirm the condition and status of the LZ. **(T-2)**.

**4.13. LZ Survey Approval.** The MAJCOM/A3, Air Component Commander, COMAFSOF (O-6) or equivalent, or their designated representative is final survey approval authority and approval is designated by signature. Signature may be digital or ink. Surveys approved by a delegated authority will have a copy of the letter of delegation attached as part of the supporting documentation. **(T-0).**

4.13.1. Approval Authority. The MAJCOM/A3, Air Component Commander, or designated authority has ultimate authority over the completed Survey and may authorize changes, inclusion, or updates to the LZ Survey without referring to the original surveyor or safety of flight reviewer.

4.13.2. Survey Approval and Routing. The AF Form 3822 is not valid for use until it has been reviewed and recommended for use by the appropriate MAJCOM/A3, Air Component Commander, COMAFSOF or O-6 equivalent, or designated authority. Submit the fully signed and completed survey in accordance with **paragraph 2.3.6.**

4.13.3. Limit of Approval Authority Responsibility. The signatory MAJCOM/A3, Air Component Commander, or designated authority is not responsible for the maintenance of the LZ. The executing authority retains all responsibility for approving use of the survey.

## Chapter 5

### HELICOPTER LANDING ZONE OPERATIONS

**5.1 General.** Helicopter and tiltrotor aircraft require HLZ procedures to safely operate in areas unsuitable for fixed-wing aircraft or outside of valid airfields. HLZs are dependent on the aircraft type, size and intended operations to include but not limited to takeoffs and landings, hover, Alternate Insertion Extraction (AIE). HLZ surveys are not required if another survey is available (i.e., fixed wing LZ survey, FARP survey, or DZ survey) as long as the survey clearly annotates applicable hazards. HLZ and tactical HLZ surveys support AIE operations unless otherwise specified. HLZ and tactical HLZ surveys intended for landings, takeoffs, or AIEs onto structures must include structural limits to support specified aircrafts and operations.

**5.2. HLZ Survey Selection.** Selecting the HLZ location is the joint responsibility of the AC and the ground unit commander. In addition to this guidance, HLZ selection will adhere to MDS specific guidance. **(T-2). Warning:** HLZ selection is dependent on the aircraft type or size. WBC is not normally a factor but must be considered if the landing area is a platform raised from the surface or is constructed of a material other than compact earth, rocks, or sand. **(T-2).** Exercise additional care to ensure the HLZ is cleared to prevent possible engine damage or personnel injury from flying debris due to hover operations. **(T-2).**

**5.3. HLZ Markings.** Markings are not required for day or night aided (e.g., NVG, infrared) operations. Unaided (e.g., non-NVG, non-infrared) night operations require a minimum of three overt lights to clearly mark the edges of the landing aircraft's footprint. **(T-3).** Lights may be configured as indicated in **Figure A6.9**, however the samples provided are not all inclusive. Refer to service, NATO and partner standard tactics, techniques and procedures for further examples.

5.3.1. Added. To prevent damage to aircraft and injury to personnel, all marking equipment (panels, markers, supports, lights, etc.) must be adequately secured to the ground to withstand the prop-wash, rotor-wash, and/or jet-blast created by the associated aircraft using the marked LZ.

**5.4. HLZ Survey and Assessment Requirements.** The HLZ survey program is a tactics office function. Squadron tactics, or designated office, must ensure surveys are conducted in accordance with the procedures below and **Attachment 6**. **(T-2).**

5.4.1. **HLZ Survey Requirements and Responsibilities.** Completing the HLZ survey involves a physical inspection/evaluation of the HLZ, documenting the information on the AF Form 4303, *Helicopter Landing Zone Survey* (see **Attachment 6**), a safety of flight review and final approval/disapproval. If the survey was conducted using any other method than on-site GPS-derived coordinates, surveyors provide the reviewer with the method conducted and raw coordinate data, level of accuracy, and any conversion(s). Though HLZ survey is not required for an AIE-only site, AIE-only site may be documented utilizing a HLZ survey and surveyor shall include the following restriction: "Restricted to Alternate Insertion Extraction use only, not intended for landing or takeoff". **(T-2).** AF Tiltrotor units (AFSOC) do not require HLZ surveys for MAJCOM/Joint Chief of Staff-directed exercises or contingency operations. **(T-2).** However, the requirement to complete an AF Form 4303 or to conduct a tactical HLZ for training shall remain in effect. **(T-2).**

5.4.1.1. HLZ surveys document the conditions that existed at the time of the survey's completion and may not account for changes to seasonal topography or vegetation encroachment. Base recommended uses on minimum requirements and do not misconstrue recommendations to be all-inclusive (e.g., HLZ recommended for two HH-60s may not be suitable for a CV-22). It is the responsibility of the flying and ground units involved to ensure that any HLZ being considered for use meets the requirements for their specific operation. Users must ensure the survey is completed and meets the appropriate criteria for operational and safety standards. **(T-2)**. The user should conduct a physical inspection and assessment of the HLZ prior to use to identify and evaluate potential hazards to personnel, equipment, man-made or natural structures and ground personnel in accordance with [paragraph 5.5](#) Recommend adding photos of the HLZ during winter (snow covered) and summer to account for seasonal weather changes using the survey and/or assessment process.

5.4.1.2. Use a 1:50,000 scale chart or less when available for the objective area for the ingress and egress. Use MAJCOM approved government owned or civilian owned technologies, mapping/imagery programs, or flight/mission planning software instead of paper charts. The review lists all obstructions such as terrain, towers, or power lines that may affect the helicopter's route of flight. Also listed on the review are any prohibited areas, noise sensitive areas, special use airspace, route of flight to avoid such areas, preferred routing, NOTAM requirements, etc.

5.4.1.3. HLZ Surveyors. CCT/STO, Pathfinders, qualified DoD civilians or contractors, qualified rotary/tiltrotor wing aircrew members, group weapons and tactics personnel, sister service rotary/tiltrotor wing aircrew, AFSPECWAR, and any other SOF or conventional personnel in aviation/airfield related specialties with the knowledge and unit training are authorized to complete the physical inspection of the HLZ and annotate the AF Form 4303. Regardless of who conducted the survey or assessment, the commander of the using unit shall be responsible for ensuring the HLZ meets the criteria for HLZ operations. **(T-2)**. **NOTE:** RAAF CCT that meet qualification, certification and currency in accordance with AFSOC/A3T validated AUS-LMP *Assault Zone Reconnaissance Course* and this manual are approved to conduct HLZ surveys and/or assessments for USAF approval.

5.4.2. HLZ Survey Conduct and Review Process. The following paragraphs outline the HLZ conduct and review process from performing the initial groundwork to the final coordination. Forward all completed surveys to the group tactics office, or an office with an equivalent level of expertise. **(T-2)**. Re-accomplish surveys when the user and/or provider determine changes in the ground or air aspects of the HLZ data require a new survey. **(T-2)**. Users and surveyors may maintain Talon Point accounts for access to current HLZ surveys and to view/submit assessments when able.

5.4.2.1. A surveyor will conduct the HLZ survey (AF Form 4303, [Attachment 6](#)), during daylight in accordance with [paragraph 5.4.1.3](#). **(T-2)**. The surveyor performs the ground evaluation of the HLZ site (e.g., measurements, coordinates, calculating size, obtaining maps and creating diagrams) and annotates results on the AF Form 4303. The surveyor may be a member of the unit that intends to use the HLZ, or a member of another unit may perform the ground portion of a survey if requested and time permits. To facilitate future use of surveyed HLZs, initial surveys will encompass the largest area available and will

not be limited by specific mission requirements. **(T-2)**. The surveyor will forward the completed survey to the group tactics office, or the Group/CC's or O-6 equivalent's designated office, for review. **(T-2)**. Include recommended use and any deviations from HLZ standards contained in service or MAJCOM directives on block 9, remarks, of the HLZ Survey.

5.4.2.2. The reviewer, in order of preference, is chief (or flight commander) of unit tactics, assistant operations officer, squadron operations officer (or the office designated by MAJCOM supplement) or AC. The reviewer ensures the HLZ can be safely used from a flight perspective and annotates a review was completed on the AF Form 4303, item 4B. Throughout the review process, HLZ survey packages will include all applicable maps, photos, charts, and diagrams necessary to determine the safety and utility of the HLZ. **(T-2)**.

5.4.2.3. Approval Authority (AF Form 4303, item 4C). Prior to use, the Group/CC, or O-6 equivalent or higher with authority over aviation missions or assets will approve surveys for air operations. **(T-2)**. Approval authority may be delegated to deputy Group/CC, squadron commander, squadron operations officer, or assistant operations officer. This approval assures the review has been accomplished and the HLZ is considered safe for air operations. Tactical HLZ surveys do not require a signature and are approved for use in accordance with **paragraph 5.4.3**.

5.4.2.4. Once item 4C of AF Form 4303 is completed, the survey is ready for use. Respective group tactics offices are the local area repositories for HLZ surveys. The group tactics office will ensure new surveys are uploaded to Talon Point. **(T-2)**. When conducting operations at any surveyed HLZ, the commander of the using unit shall be responsible for ensuring the HLZ meets the criteria for that operation **(T-2)**. In all cases, the using unit must accept responsibility for all personnel injuries and property damage. **(T-2)**.

5.4.2.5. Host Nation (HN) or Joint HLZ Surveys. When conducting operations on or over a HN surveyed HLZ, complete a safety of flight review of the HN survey before operations to the HLZ begin. **(T-2)**. Users remain responsible for ground operational and safety criteria. Use Joint or Host nation HLZ surveys in place of the AF Form 4303 process as long as the survey has been reviewed and all criteria required within the AF Form 4303 are covered.

5.4.3. Tactical HLZ Surveys. Tactical HLZ surveys may be required to meet the appropriate commander's objective(s). Conduct tactical HLZ surveys when emergent time critical operations, training objectives, or operational environment do not allow for completion of the AF Form 4303 process or on-site physical survey of the objective area intended for landing/departing aircraft. HLZs may be tactically surveyed by aircrew, ground forces, or the use of imagery. Aircrew should conduct an airborne (hi-low assessment) of tactical HLZ prior to landing. Though tactical HLZ surveys do not require an AF Form 4303, minimum Tactical HLZ requirements are identified by asterisks within **Attachment 6**, Guidance Concerning AF Form 4303. MAJCOMs may determine standard tactical HLZ survey format. For routine use, complete an AF Form 4303. **(T-2)**. Additional Joint tactical HLZ operations, considerations and briefing within AFTTP 3-2.6, JFIRE, *Multi-Service Tactics, Techniques, and Procedures for Joint Application of Firepower*, Appendix G and tables 91 and 92, may be found at <https://www.alsa.mil/mttps/jfire/>.

5.4.3.1. Though preferable, the use of an AF Form 4303 is not required for a tactical survey.

5.4.3.2. When using a tactical HLZ, the using unit assumes roles/responsibility for safety of flight and approval for use.

**5.5. HLZ Survey Assessments/Updates.** Assess existing HLZ surveys every 12 months. **(T-2).** HLZs that are not assessed in the twelve-month time period will be closed until reviewed using the above criteria (does not require a new AF Form 4303). **(T-2).** The minimum requirement to assess a HLZ survey requires a HLZ surveyor in accordance with **paragraph 5.4.1.3** to physically evaluate the HLZ. The surveyor must ensure items six through ten of AF Form 4303 are still accurate. **(T-2).** Report assessment of HLZ survey in Talon Point database. If not updated in Talon Point, physically annotate date assessed and surveyor's name and unit in block 9, remarks, of the HLZ Survey until Talon Point inclusion. An HLZ survey that has not been updated for 24 months is expired and a resurvey of the AF Form 4303 is required (requires new reviewer and approver signatures). **(T-2).** When significant changes are identified at any time or during an assessment (e.g., obstacles that affect flight or landing safety), the HLZ requires a resurvey. An HLZ survey expires 5 years from original date surveyed at which point a new survey must be conducted. **(T-2).** **NOTE:** AFGSC will establish requirements in their supplement for updating missile alert facilities and launch facility surveys. **(T-2).**



## Chapter 6

### LC-130 SKIWAY AND SKI LANDING AREA CRITERIA

**6.1 General.** These procedures apply to all agencies involved in or supporting LC-130 operations and clarify LC-130 Polar LZ requirements. The waiver authority for non-tiered compliance items in this chapter is the 109<sup>th</sup> Operations Group Commander (109 OG/CC).

**6.2. Selection of LC-130 Landing Sites.** Proposed landing sites must be submitted to 109 OSF/OSK Polar Tactics at: 1 Air National Guard Road, Scotia, NY 12302-9752. Phone: Comm 518-344-2640, or DSN 344-2640. Agencies must also provide information on ice depth and surface characteristics when applicable. Minimum thickness is discussed in [Table 6.1](#).

**6.3. LC-130 Polar LZs.** Polar LZs are LC-130 landing surfaces that include ski airfields (skiways & ski landing areas (SLAs)), ice runways and open snow areas.

6.3.1. Ski Airfields. Ski airfields are prepared (groomed), skis-only polar LZs marked as either skiways or SLAs in accordance with this DAFMAN.

6.3.2. Ice Runways. These are prepared for wheeled operations and may be constructed on compacted snow or native ice. Mark ice runways in the same manner as ski airfields.

6.3.3. Open Snow Areas. These are generally unprepared, skis-only, open-field landing areas with limited or no markings. Open snow areas include snow fields, glaciers and snow-covered ice sheets. Due to lack of surface preparation and airfield markings, open snow operations present unique risk elements which require mitigation.

**6.4. Maximum Aircraft Gross Weight.** The LC-130 C2 establishes the maximum gross weights for LC-130 operations at specific polar LZs.

6.4.1. Variables Affecting Maximum Operating Gross Weight. Variables which affect maximum aircraft operating gross weight include surface roughness, hardness, ice thickness, snow cover and snow depth. These characteristics should be continually monitored and evaluated for their effect on allowable aircraft gross weight, particularly when the LZ has been left unattended or after severe weather conditions.

6.4.2. Surface Preparation. Generally, an increased level of surface preparation or grooming will allow for increased operating weights. A four-inch elevation change in 20 feet is the threshold for what is considered “smooth.” If this threshold is exceeded, structural damage to the skis may occur at higher operating weights.

6.4.3. Maximum Aircraft Gross Weight References. For detailed maximum aircraft operating gross weight information, refer to 109<sup>th</sup> AW supplements to AFI 11-2C-130V3ADDD, *LC-130 Ski Procedures* and Technical Order (T.O.) 1C-130(L) H-1, *Flight Manual*.

**6.5. Ski Landing Area.** Several agencies and a large body of scientific research have conducted extensive research and testing of ice characteristics and testing data is available to agencies interested in ice field or sea ice operations.

6.5.1. Ice Weight Bearing Capacity. The load bearing capacity of ice sheets varies with thickness, surface temperature, weight of the aircraft and parking time. Minimum ice thickness required for LC-130 operations is based on data derived from U.S. Naval Civil Engineering Lab, Technical Report R860, *Ice Engineering - Study of Related Properties of Floating Sea-*



*Ice Sheets and Summary of Elastic and Viscoelastic Analyses*, Canadian Forces Air Command Manual (CFACM) 10-100, *Air Transport Group Ice Strip Requirements for CC 130 Hercules, CC 115 Buffalo, and CC 138 Twin Otter Operations* and LC-130 aircraft field experience. The limits in **Table 6.1** are established as minimum values for LC-130 aircraft. They may be applied up to the maximum ski landing/takeoff gross weights listed in T.O. 1C-130(L) H-1, Operations with ambient temperature above freezing must be evaluated and approved in accordance with applicable LC-130 C2.

**Table 6.1. Ice Weight Bearing Capacity.**

SURFACE TEMPERATURE	MINIMUM ICE THICKNESS
-10 deg C or less	55 inches
-10 to -5 deg C	60 inches
-5 to 0 deg C	85 inches

6.5.2. Ski Landing Area Testing. Conduct testing of ice sheet depth at landing/takeoff areas by drilling through the ice at 500-foot intervals on alternated sides for the entire length of the landing area. Minimum depth values will not include surface snow or slush. Perform additional drill tests weekly during continuous operations or prior to resuming landings/takeoffs after a period of non-use of more than one week. Check the area regularly for signs of cracking or surface deterioration.

**6.6. Surface Suitability.** Surface evaluation of potential landing/takeoff areas is necessary to assure the area is suitable for LC-130 ski operations. The better the natural conditions, the less preparation work will be necessary. The best condition is a relatively smooth surface with 2 or more years of snow accumulation to a depth of 12 inches (the minimum acceptable depth is six inches). Unsuitable Surface Conditions are as follows. Avoid the following conditions:

6.6.1. Undulating or irregular ice. Undulating or irregular ice underneath the snow surface, often hidden by the snow cover, can impact the skis during landing or takeoff which may damage skis and other aircraft structure. Ice irregularities can do significant damage to skis when struck at any speed; an ice crack or pressure ridge with an edge of more than four inches may do damage at taxi speeds as the ski bridges the crack and a stress point is applied to the ski.

6.6.2. Bare ice with little or no snow cover. Snow cover is required to cushion and distribute loads over the skis. Even small irregularities or cracks in bare ice can create stress points along the ski that can cause damage.

6.6.3. Large irregularities in the snow surface. (ridges, humps and surface irregularities created by wind action known as "sastrugi"). Sastrugi, ridges, or humps more than four inches may do damage at taxi speeds as the ski bridges the crack and a stress point is applied to the ski. These irregularities require extensive surface preparation before ski operations or damage to skis may occur.

**6.7. Surface Preparation and Maintenance.** The agency being supported is responsible for preparing the surface. Surface preparation must include a thorough survey of the landing area to look for ice irregularities and study snow depths and characteristics. Remove any unacceptable irregularities. Snow irregularities may be large enough to require the entire surface to be dragged or graded to fill low areas and remove high areas. Grade all undulating surfaces to minimize the

slope and prevent ski damage. Be careful to not remove the entire snow surface down to bare ice because snow cushions and distributes loads during ski takeoffs and landings. If the resulting surface is acceptable, ski operations can begin after appropriate marking and certification.

6.7.1. Dragging. Dragging is required to remove sastrugi, ridges, or humps; grade undulating, uneven, or rough surface areas; and promote ice crystal deformation to harden the loose surface snow. Various types of drag devices have demonstrated effectiveness.

6.7.2. Cargo Loading Area Grooming. Groom the cargo loading area (**Figure 6.2**) to harden the surface prior to supporting cargo operations.

6.7.3. Periodic Maintenance. Maintaining the Skiway or SLA will require periodic dragging. Drag the Skiway or Ski Landing Area immediately after fresh snow accumulation, windstorms, or when ski landings/takeoffs have disturbed the surface. Regular inspections by the ground party and pilot reports will determine if dragging or other maintenance action is required.

6.7.4. Ski Landing Area Control Officer (SLACO) Certified Ski LZs. A SLACO will certify ski LZs with a snow surface over an ice substrate. The C2 will authorize as defined in applicable theater addenda. See **paragraph 6.9** for further SLACO information.

## 6.8. Ski Airfield Markings and Layout.

6.8.1. Standard Operations. Mark skiways and ice runways in accordance with **Figure 6.1**, **Figure 6.2** and **Figure 6.3** Mark SLAs in accordance with **Figure 6.5** The length and width of the marked area may vary with field elevation, snow conditions, operating gross weight and duration of use. Minimum length and width is 5,000 feet x 150 feet at sea level. Greater length and width may be required at higher elevations. 109<sup>th</sup> AW will coordinate with the supported agency to determine length and width for development of a particular Skiway. In addition to skiway markings, mark a cargo loading area (**Figure 6.3**). Locate a cargo loading area either adjacent to the skiway or further removed according to camp requirements. Accumulated cargo or other structures must not be closer than 75 feet from any skiway edges. Skiway markers are made from nylon mesh and mounted on bamboo poles (**Figure 6.4**).

6.8.2. Temporary Operations. Operations of a temporary nature requiring limited ski landings/takeoffs may not require skiway approach markings. The 109<sup>th</sup> AW, in coordination with the supported agency, will determine whether to establish an SLA or skiway for a particular operation.

6.8.3. Flagging Guidance. The primary differences between skiways and SLAs are the absence of lead-in flags and fewer marking flags for an SLA.

6.8.3.1. Skiway. Minimum flagging for a skiway should consist of the following (**Figure 6.1**):

6.8.3.1.1. Mark the thresholds and midpoints with five red flags, laterally spaced, on each side.

6.8.3.1.2. Place three black flags for each grouping along the full length of both sides at 400-foot intervals. A clearly recognizable and contrasting number two (white is recommended) attached to inside flags on both sides of the skiway at 2,000 feet remaining from each Skiway departure end.

6.8.3.2. Ski Landing Area. Minimum flagging for a typical SLA should consist of the following (**Figure 6.4**):

6.8.3.2.1. The thresholds and midpoints will be marked with five red flags, laterally spaced, on each side.

6.8.3.2.2. Place two black flags for each grouping along the full length of both sides of the Ski Landing Area at 400-foot intervals. A clearly recognizable and contrasting number two (white is recommended) attached to inside flags on both sides of the SLA at 2,000 feet remaining from each SLA departure end.

6.8.4. NVG Operations in the Polar Regions. NVG lighting for operations may not coincide with AMP configurations. Due to the barren, featureless nature of polar and open-snow terrain, ski NVG lighting should more closely coincide with skiway and ski landing area flagging requirements. The aircrew will complete a table top review of the NVG lighting configuration prior to missions involving non-standard NVG lighting configurations.

**6.9. Ski Landing Area Control Officer (SLACO).** SLACOs are typically highly experienced LC-130 pilots, navigators, or combat systems officers who evaluate LC-130 landing sites. The 109 AW (ANG unit) develops and maintains procedures to train and certify SLACOs. Due to operational constraints, CCT/STO or polar field experts experienced in LC-130 operations and designated by LC-130 command authority may fulfill SLACO duties.

Figure 6.1. Skiway Lead-In Markings.

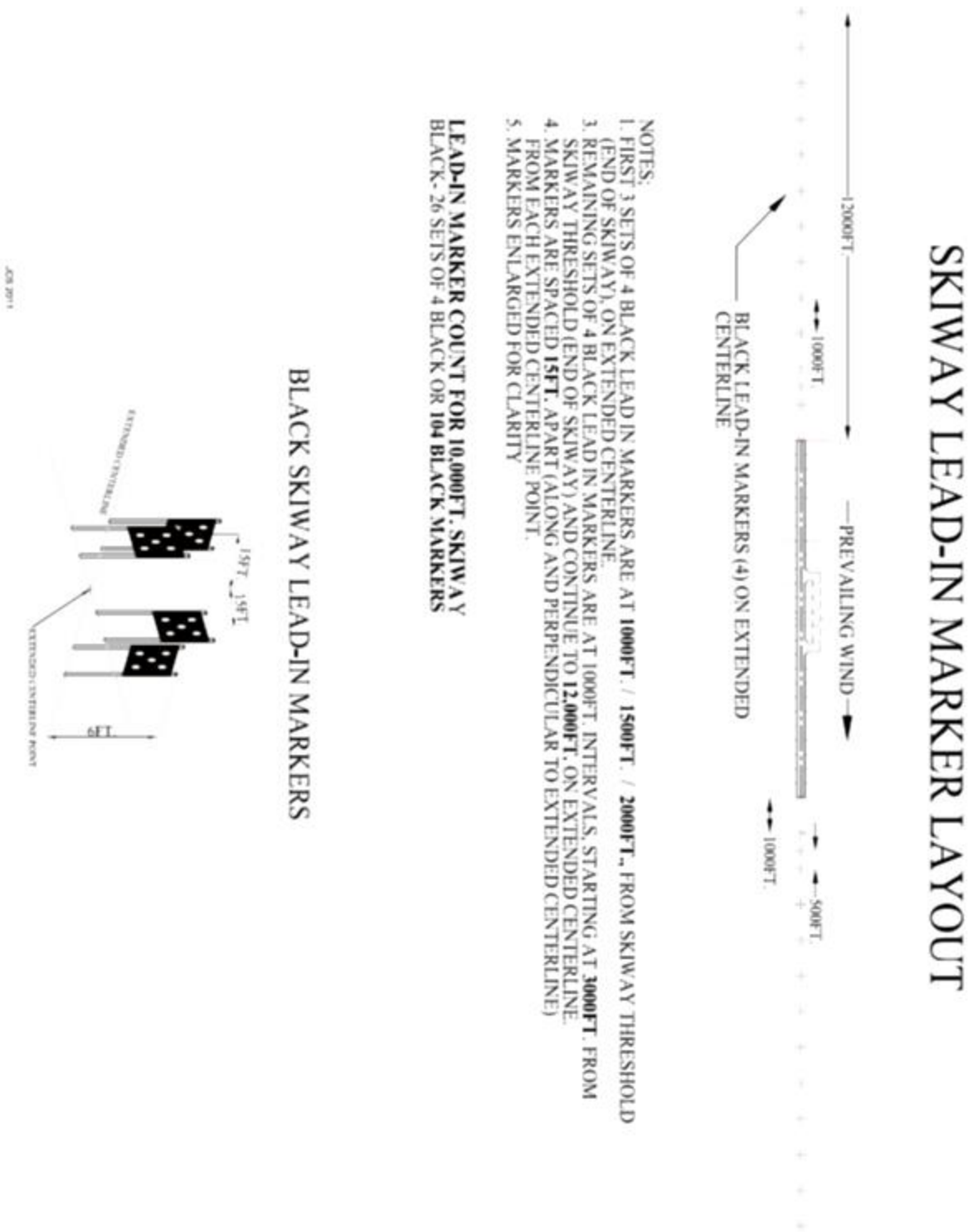

Figure 6.2. Skiway Edge Markings.

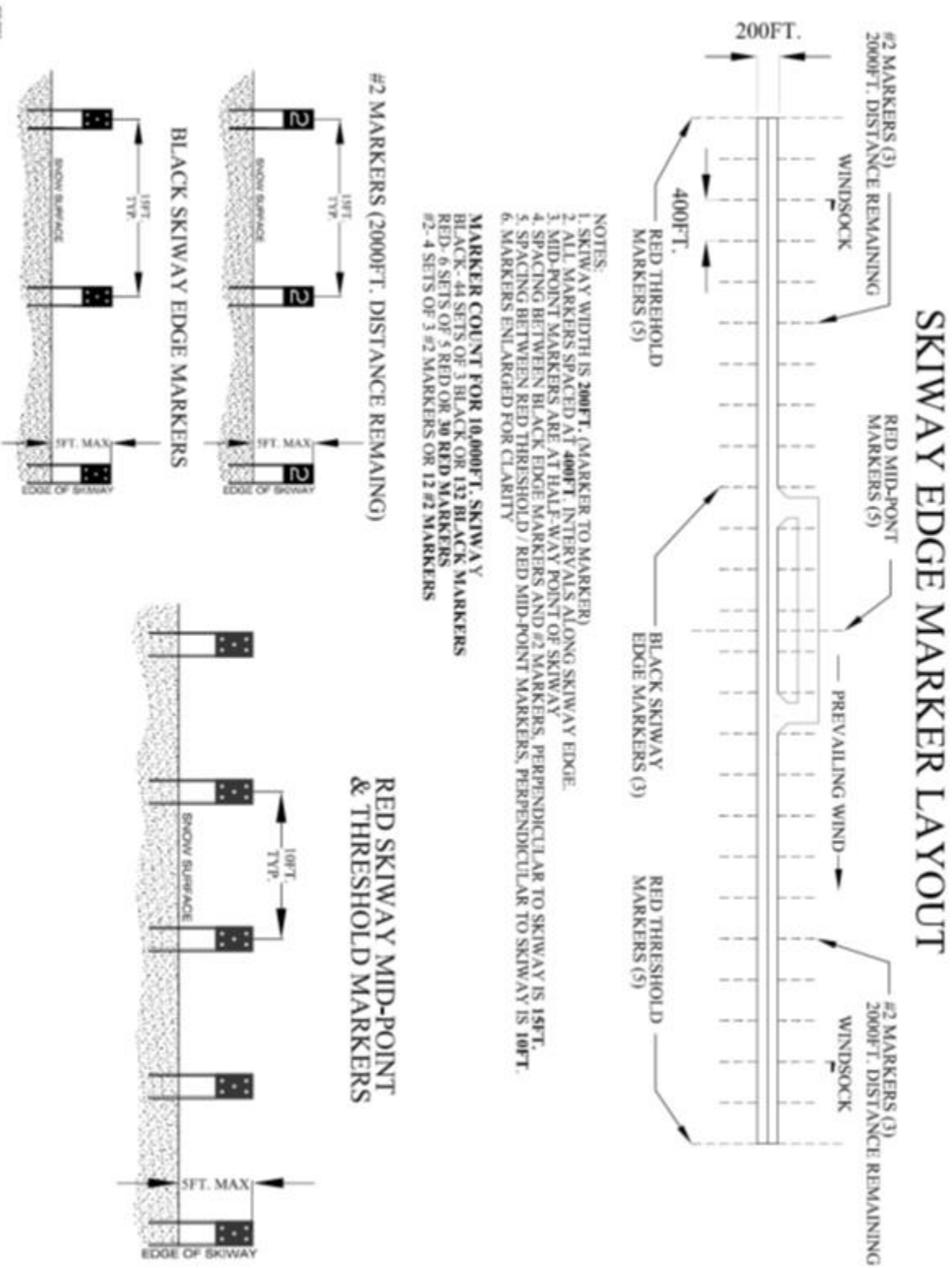

Figure 6.3. Skiway Apron Layout.

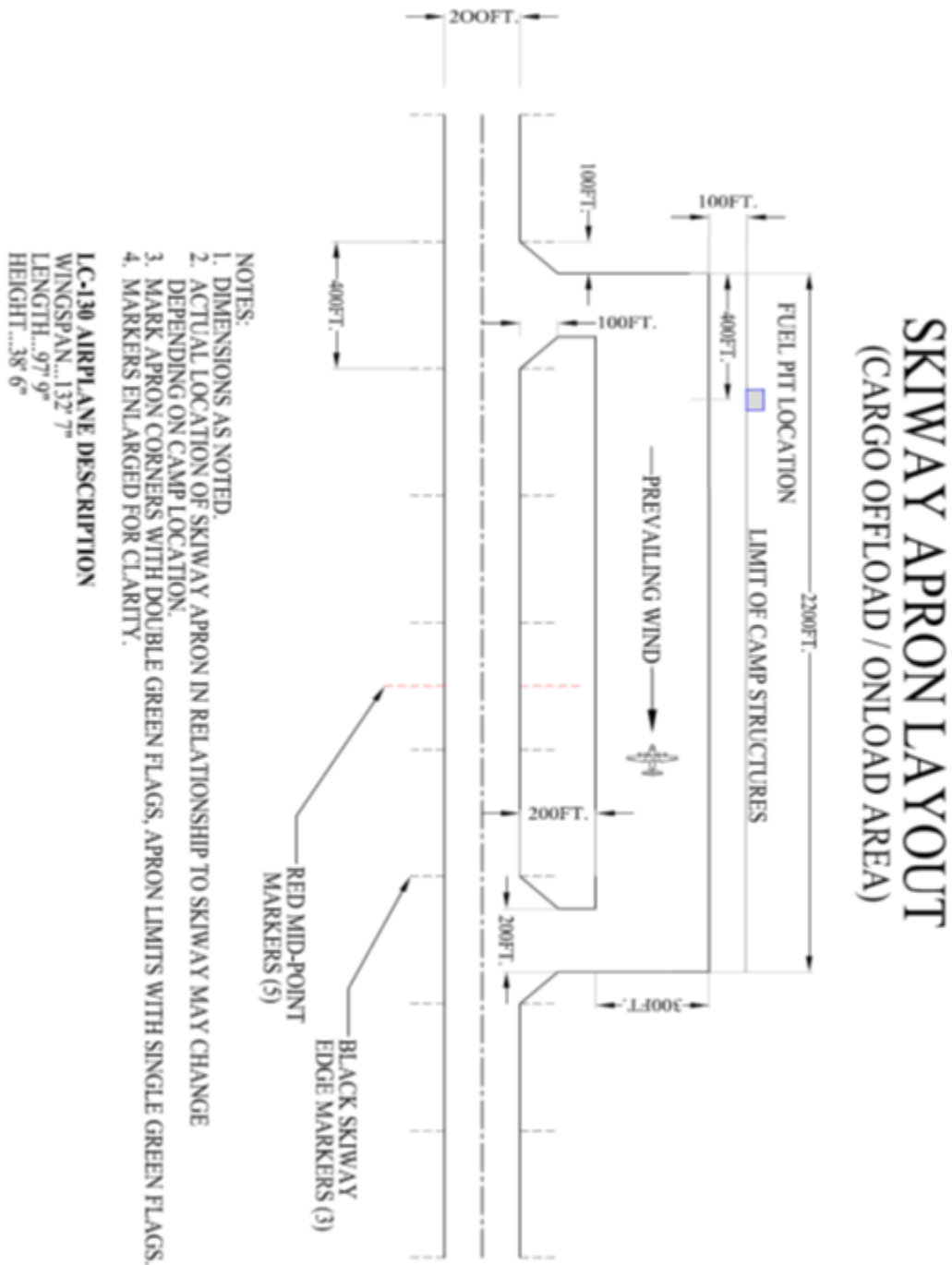



Figure 6.4. Skiway Marker Detail.

- NOTES:
1. ALL MARKERS MADE OF SOLID (BLACK OR RED) TNX 18 FABRIC MOUNTED WITH #8 x 3/4" SHEET METAL SCREW W/ 1" RUBBER BACKED WASHER, ON 1.5" BAMBOO X 8FT. LONG.
  2. MARKER SLEEVES ARE REINFORCED AND WRAPPED WITH ALUMINUM FOIL TO INCREASE RADAR SIGNATURE.
  3. 5 HOLE PATTERN IS TO REDUCE WIND RESISTANCE. HOLE SIZE IS 3".
  4. #2 IS WHITE ON BLACK MARKER

DPS 0011

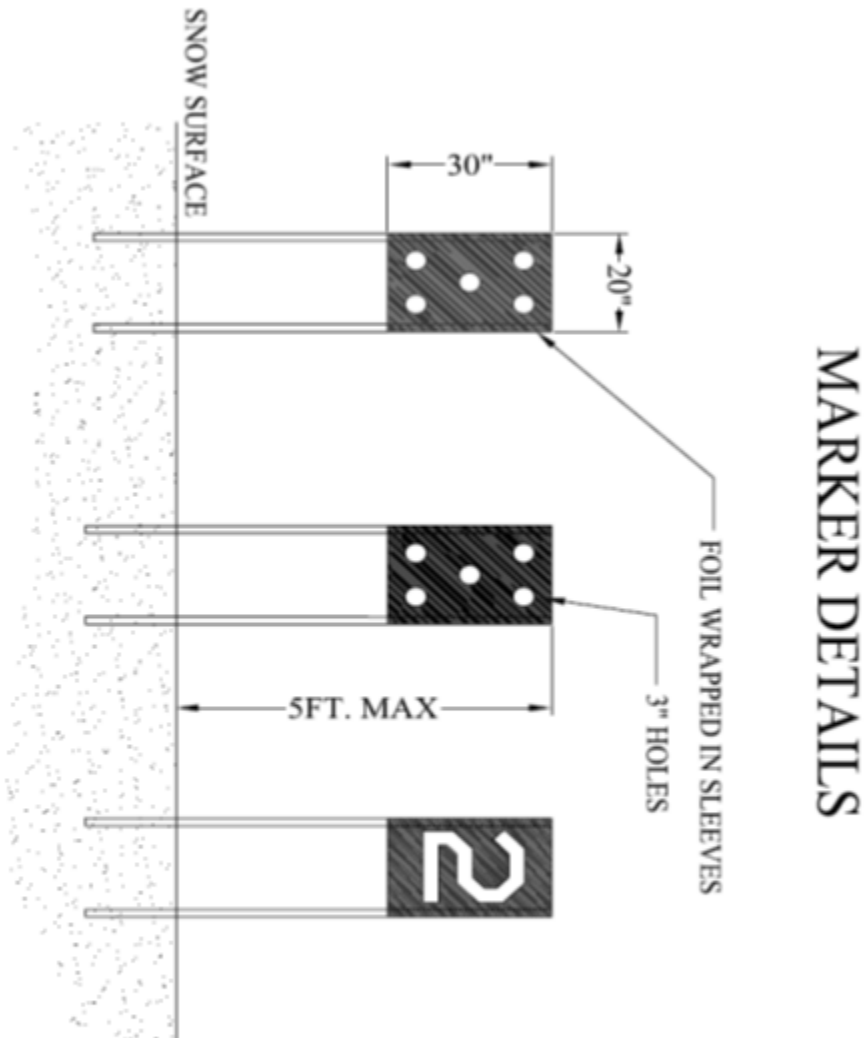
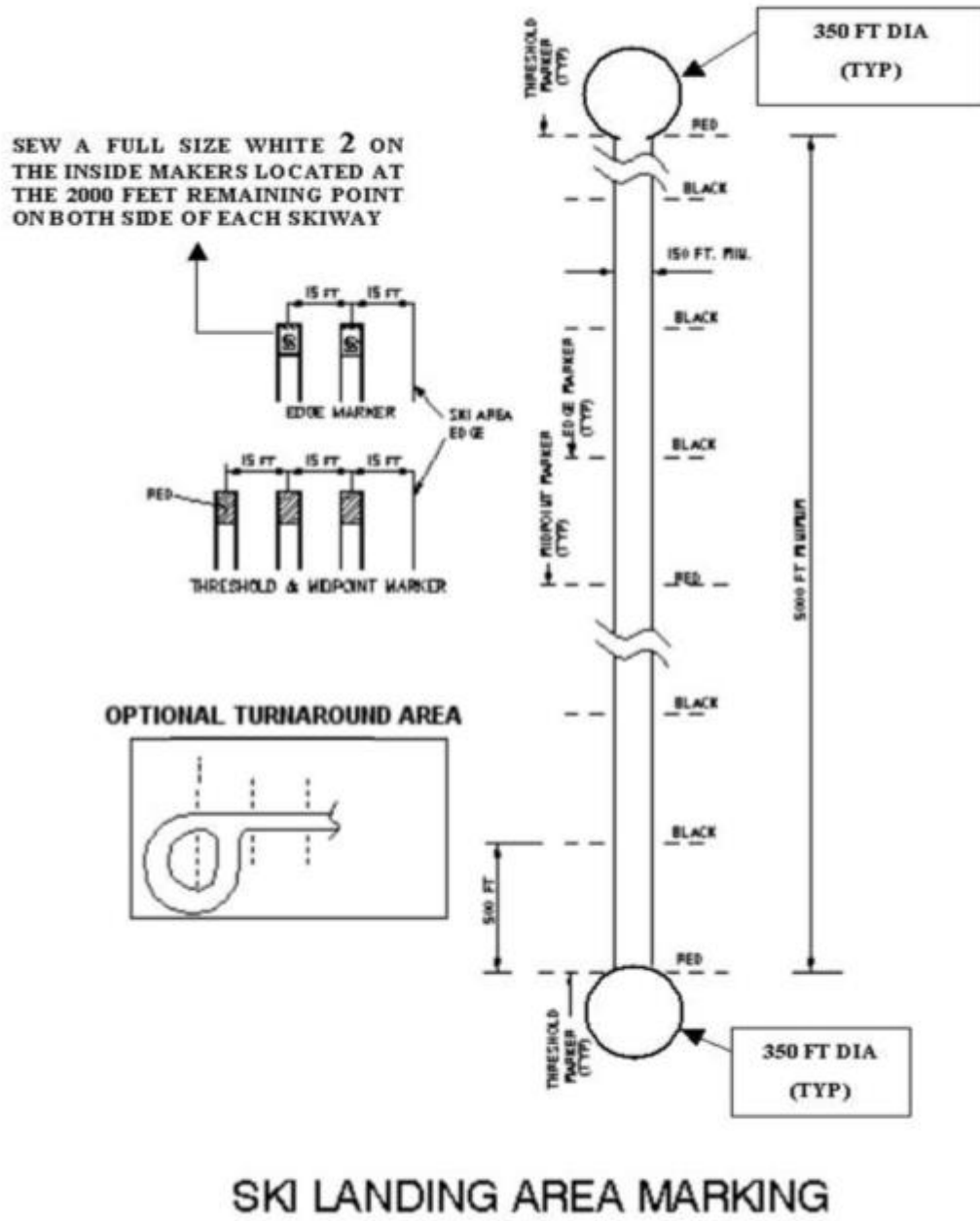

Figure 6.5. Ski Landing Area Marking.



Deputy Chief of Staff, Operations

**Attachment 1****GLOSSARY OF REFERENCES AND SUPPORTING INFORMATION*****References***

AFI 33-322, *Records Management and Information Governance Program*, 23 March 2020

ATP 3-18.11, *Special Forces Military Free-Fall Operations*, 28 April 2020

STANAG 3344, *Tactics, Techniques, and Procedures for NATO Airborne Operations*, 12 February 2018

AFI 10-3503, *Personnel Parachute Program*, 23 September 2020

AFI 11-235, *Specialized Fueling Operations*, 31 May 2019

AFMAN 11-231, *Computed Air Release Point Procedures*, 18 November 2020

AFMAN 11-420, *Static Line Parachuting Techniques and Training*, 24 October 2018

AFMAN 11-218, *Aircraft Operations and Movement on the Ground*, 5 April 2019

AFTTP 3-2.6, *JFIRE Multi-Service Tactics, Techniques, and Procedures for Joint Application of Firepower*, October 2019

AFMAN 13-106, *Air Mobility Liaison Officers (AMLO)*, 7 December 2020

AFJ 13-210(I), *Joint Airdrop Inspection Records, Malfunction/Incident, Investigations, and Activity Reporting*, 23 June 2009

AFI 91-204, *Safety Investigation and Hazard Reports*, 27 April 2018

AFMAN 11-202 Volume 3, *Flight Operations*, 10 June 2020

UFC 3-260-01, *Airfield and Heliport Planning and Design*, 4 February 2019

AFPAM 32-2004, *Aircraft Fire Protection for Exercises and Contingency Response Operations*, 25 September 2014

Combat Control *Career Field Education and Training Plan (CFETP) 1Z2X1*

CFACM 10-100, *Air Transport Group Ice Strip Requirements for CC 130 Hercules, CC 115 Buffalo, and CC 138 Twin Otter Operations*, March 1982

U.S. Naval Civil Engineering Lab, Technical Report R860, *Ice Engineering - Study of Related Properties of Floating Sea-Ice Sheets and Summary of Elastic and Viscoelastic Analyses*, December 1977

AFI 11-2C-130V3ADDD, *LC-130 Ski Procedures*, 22 July 2016

AFMAN 13-204V3, *Air Traffic Control*, 22 July 2020

AFMAN 15-111, *Surface Weather Observations*, 12 March 2019

DAFPD 13-2, *Air Traffic Control, Airfield, Airspace, and Range Management*, 3 January 2019

AMCI 11-208, *Mobility Air Forces Management*, 8 February 2017

DAFI 33-360, *Publications and Forms Management*, 1 December 2015

TC 18-11, *Special Forces Double-Bag Static Line Operations*, 28 April 2020

Memorandum of Agreement, *Airdrop Operations Without Air Force Combat Control*, 24 June 1987

T.O. 1C-130(L) H-1 with Change 12, *Flight Manual*, 4 June 2020

TSPWG M 3-260-03.02-19, *Airfield Pavement Evaluation Standards and Procedures*, 19 October 2020

AFI 11-200, *Aircrew Training, Standardization/Evaluation, and General Operations Structure*, 20 September 2018

AMC *Airfield Suitability and Restrictions Report*, 07 January 2019

AUS-LMP, *Assault Zone Reconnaissance Course*, 1 November 2020

FAA Order JO 7110.65Y with Change 1-3, *Air Traffic Control Order*, 31 December 2020

### ***Prescribed Forms***

AF Form 3823, *Drop Zone Survey*

AF Form 3822, *Landing Zone Survey*

AF Form 4303, *Helicopter Landing Zone Survey*

AF Form 4304, *Drop Zone Landing Zone Control Log*

### ***Adopted Forms***

AF Form 847, *Recommendation for Change of Publication*

SOCOM Form 111, *USSOCOM JAAAC Mission Request Sheet*

### ***Abbreviations and Acronyms***

**AC**—Aircraft Commander

**ACP**—Assessment Cone Penetrometer

**ADE**—Airdrop Damage Estimate

**AF**—Air Force

**AFB**—Air Force Base

**AFCEC**—Air Force Civil Engineer Center

**AFI**—Air Force Instruction

**AFMAN**—Air Force Manual

**AFPAM**—Air Force Pamphlet

**AFR**—Air Force Reserve

**AFSC**—Air Force Specialty Codes

**AFSOC**—Air Force Special Operations Command

**AFSPECWAR**—Air Force Special Warfare  
**AFTTP**—Air Force Tactics Techniques and Procedures  
**AGL**—Above Ground Level  
**AMC**—Air Mobility Command  
**AMD**—Air Mobility Division  
**AMCI**—Air Mobility Command Instruction  
**AMLO**—Air Mobility Liaison Officers  
**AMP**—Airfield Marking Patterns  
**ANG**—Air National Guard  
**AOC**—Air Operations Center  
**APZ**—Accident Potential Zones  
**ARFF**—Aircraft Rescue and Fire Fighting  
**ASRR**—Airfield Suitability and Restrictions Report  
**ATC**—Air Traffic Control  
**AW**—Air Wing  
**AUS-LMP**—Australia Department of Defence Learning Management Package  
**C2**—Command and control  
**CARP**—Computed Air Release Point  
**CBR**—California Bearing Ration  
**CCT**—Combat Control Team personnel  
**CDS**—Container Delivery System  
**CFETP**—Career Field Education and Training Plan  
**COMAFSOF**—Commander Air Force Special Operations Forces  
**CONUS**—Continental United States  
**CR**—Contingency Response  
**CRG**—Contingency Response Group  
**CRL**—Container Ramp Loads  
**CRS**—Container Release System  
**CSAR**—Combat Search and Rescue  
**DAFI**—Department of the Air Force Instruction  
**DAFMAN**—Department of the Air Force Manual  
**DBSL**—Double Bag Static Line



**DCP**—Dynamic Cone Penetrometer  
**DoD**—Department of Defense  
**DSN**—Defense Switched Network  
**DZ**—Drop Zone  
**DZC**—Drop Zone Controller  
**DZSO**—Drop Zone Safety Officer  
**DZST**—Drop Zone Support Team  
**DZSTL**—Drop Zone Support Team Leader  
**FAA**—Federal Aviation Administration  
**FARP**—Forward Arming and Refueling Point  
**FCIF**—Flight Crew Information File  
**FOD**—Foreign Object Damage  
**GDSS**—Global Decision Support System  
**GENC**—Geopolitical Entities Names and Code  
**GMRS**—Ground marked release system  
**GPS**—Global positioning system  
**GSR**—Glide Slope Ratio  
**HLZ**—Helicopter Landing Zone  
**HN**—Host Nation  
**HSLADS**—High Speed Low Level Aerial Delivery System  
**HV**—High Velocity  
**HVCDS**—High Velocity Container Delivery System  
**ICAO**—International Civil Aviation Organization  
**IMC**—Instrument Meteorological Conditions  
**JMD**—Jumpmaster directed  
**JM**—Jumpmaster  
**JPADS**—Joint Precision Airdrop System  
**LCADS-LV**—Low Cost Aerial Delivery System – Low Velocity  
**LCLA**—Low Cost/Low Altitude  
**LTFW**—Light Tactical Fixed Wing  
**LZ**—Landing Zone  
**LZC**—Landing Zone Controller

**LZSO**—Landing Zone Safety Officer  
**MAJCOM**—Major Command  
**MAWTS-1**—Marine Aviation Weapons and Tactics Squadron One  
**MDS**—Mission Design Series  
**MEW**—Mean effective wind  
**MFF**—Military Free Fall  
**MGRS**—Military Grid Reference System  
**MOS**—Military Occupational Specialty  
**MOU**—Memorandum of Understanding  
**MPI**—Multiple Points of Impact  
**MSL**—Mean sea level  
**NAF**—Number Air Force  
**NATO**—North Atlantic Treaty Organization  
**NM**—Nautical Mile  
**NAVAID**—Navigational Aid  
**NCO**—Non-Commissioned Officer  
**NOTAM**—Notice to Airmen  
**NVG**—Night Vision Goggles  
**NVD**—Night Vision Devices  
**OCONUS**—Outside Continental United States  
**OPCON**—Operational control  
**OSS**—Operations Support Squadron  
**PCN**—Pavement Classification Number  
**PI**—Point of Impact  
**PR**—Personnel Recovery  
**RAAF CCT**—Royal Australian Air Force Combat Control Team  
**RCAM**—Runway Condition Assessment Matrix  
**RCR**—Runway Condition Rating  
**RFF**—Rolling Friction Factor  
**RPI**—Random Point of Impact  
**RRM**—Rolling Resistant Material  
**RTO**—Regional Tactics Offices

**RWY**—Runway

**SATB**—Standard Airdrop Training Bundle

**SERE**—Survival, Evasion, Resistance and Escape

**SKE**—Station Keeping Equipment

**SLA**—Ski Landing Areas

**SLACO**—Ski Landing Area Control Officer

**SOCEUR**—Special Operations Command, Europe

**SOF**—Special Operations Forces

**SOI**—Syllabus of Instruction

**SPACI**—Semi-Prepared Airfield Condition Index

**STANAG**—Standardization Agreement

**STO**—Special Tactics Officers

**T.O.**—Technical Order

**TOT**—Time on/over target

**USAFE-AFAFRICA**—United States Air Forces in Europe, Air Forces Africa

**USAF**—United States Air Force

**USAFWS**—United States Air Force Weapons School

**USEUCOM**—United States European Command

**USPACOM**—United States Pacific Command

**USSOCOM**—United States Special Operations Command

**VFR**—Visual Flight Rules

**WBC**—Weight bearing capacity

**WDI**—Wind drift indicator

### *Terms*

**Air Component Commander**—The Commander AF Forces, Joint Force Air Component Commander, Coalition Forces Air Component Commander, Joint Force Special Operations Air Component Commander, Coalition-Joint Special Operations Air Component Commander, or Joint Special Operations Air Component Commander with OPCON of the asset. For assets which have OPCON transferred from another Commander, the OPCON Plan will be identified via Execution Order or Operations Order.

**Air Mobility Division**—A cell within the air operations center, which plans, coordinates, manages and executes theater airlift operations in the area of responsibility or joint operations area. Normally consists of an airlift plans branch, an airlift operations branch and an airlift logistics branch.

**Air Mobility Liaison Officer**—A rated air mobility officer trained specifically to provide air mobility expertise and close, tactical-to-strategic level combat operations support to ground forces in garrison and while deployed to contingencies or exercises. AMLOs educate, train and facilitate delivery of air mobility capabilities to operational and logistic elements of the ground component. Simultaneously, they examine air mobility operations and voice enterprise concerns to air mobility leadership. AMLOs are organized and empowered to serve as the single authoritative voice on mobility issues representing and advising the ground commanders they support.

**Aircraft Commander**—The pilot in command, regardless of rank, responsible for and the final authority for, the operation of the aircraft. Synonymous with pilot in command authority.

**Airfield Marking Pattern**—A system of designations that differentiate between the various types of airfield markings.

**Airfield Suitability and Restrictions Report**—The Airfield Suitability and Restrictions Report (ASRR) and Global Decision Support System (GDSS) Airfield Detail/Giant Report are a recognized MAJCOM mission planning tools per AFMAN 11-202V3 and requirements per mobility aircraft AFMAN 11-2MDS V3s. They establish airfield suitability and restrictions at airfields with prepared (paved) runways (non-landing zones) for the designated Air Mission Command and Air Mission Command -gained aircraft. Additional MAJCOMs may utilize and/or designate restrictions for use.

**Airlift Mission Commander**—A commander designated when airlift aircraft are participating in airlift operations specified in the implementing directive.

**Airspace Control Order**—An order implementing the airspace control plan that provides the details of the approved requests for airspace coordinating measures.

**Airspace Control Plan**—The document approved by the joint force commander that provides specific planning guidance and procedures for the airspace control system for the joint force operational area.

**Alibi Jumper**—Parachutist who has not jumped and remains aboard the aircraft. The number of alibi jumpers may be obtained to properly account for all personnel.

**Assault Zone**—A LZ, DZ, HLZ, LC-130 skiway/ski landing area, or Forward Arming and Refueling Point (FARP).

**Braking Action**—A report of conditions on the airport movement area providing a pilot with a degree/quality of braking to expect. Braking action is reported in terms of good, good to medium, medium, medium to poor, poor, or nil.

**Combat Search and Rescue Forces**—Active, reserve and guard component forces of the military services designated by the Secretary of Defense; who possess a service-level validated requirement; and are organized, trained and equipped to conduct and support combat search and rescue.

**Controlling Obstacle**—The most restrictive obstacle to air navigation within the controlling region of the approach departure clearance surface to a runway. The controlling GSR, or run over rise, for departure from a runway is evaluated from the Controlling Obstacle's height above runway elevation and distance to GSR termination point in accordance with [Table 4.2](#), [Figure 4.1](#) and [paragraph 4.3.2.3](#).

**Deviation**—An unplanned divergence from directives, instructions or operational standards.

**Displaced Threshold**—A runway threshold that is operationally required to be displaced farther beyond the surveyed primary threshold.

**Drop Zone**—A specific area upon which airborne troops, equipment, or supplies are airdropped. Also called DZ.

**Drop Zone Controller**—Qualified and certified individual in charge of a DZ operation.

**Drop Zone Safety Officer**—The appointed non-USAF representative of the supported forces commander who is responsible for the safe operation of the DZ. Specific duties and responsibilities vary according to the supported forces standard operating procedures.

**Drop Zone Support Team**—Qualified U.S. Army/Marine Corps team responsible for supporting DZ operations in accordance with this manual and memorandum of agreement.

**Drop Zone Support Team Leader**—Individual in charge of U.S. Army or Marine Corps DZ support team leader.

**End of Overrun/End of Useable**—The last point at which an aircraft can taxi or turn on safely. End of Useable is referenced when no overrun exists or is required.

**Flight Information Program**—Flight Information Publications and Flight Information Products are sensitive flight critical mapping and charting type items produced by the National Geospatial-Intelligence Agency (NGA), foreign governments and commercial vendors that are distributed by Defense Distribution Mapping and varied civilian contractors.

**Giant Report**—Global Decision Support System (GDSS) report on an airfield within the primary Mobility AFs repository of worldwide airfield suitability information. The Airfield Suitability and Restrictions Report and GDSS Airfield Detail/Giant Report establish airfield suitability and restrictions at airfields with prepared (paved) runways (non-landing zones) for the designated AMC and AMC-gained aircraft. Additional MAJCOMs may utilize and/or designate restrictions for use.

**Ground Marked Release System**—A procedure used by ground forces to determine and mark the release point for an airdrop.

**Ground Mission Commander**—A commander designated when ground units are supported by airlift operations specified in the implementing directive.

**Helicopter Landing Zone**—A specified ground area for landing helicopters to embark or disembark troops and/or cargo. A LZ may contain one or more landing sites.

**Hostile Environment**—Operational environment in which host government forces, whether opposed to or receptive to operations that a unit intends to conduct, do not have control of the territory and population in the intended operational area.

**Ice Runway**—A wheeled LZ with an ice surface, or an ice surface covered with snow.

**Joint Force Air Component Commander**—The commander within a unified command, subordinate unified command, or joint task force responsible to the establishing commander for making recommendations on the proper employment of assigned or attached, and/or made available for tasking air forces; planning and coordinating air operations; or accomplishing such operational missions as may be assigned. Also called JFACC.

**Joint Force Special Operations Component Commander**—The commander within a unified command, subordinate unified command, or joint task force responsible to the establishing commander for recommending the proper employment of assigned, attached, and/or available for tasking special operations forces and assets; planning and coordinating special operations; or accomplishing such operational missions as may be assigned. Also called JFSOCC.

**Joint Special Operations Air Component Commander**—The commander within the joint force special operations command responsible for planning and executing joint special operations air activities. Also called JSOACC.

**Landing Zone**—Any planned landing surface and movement area that has not been evaluated or does not meet defined airfield criteria. LZ may be unprepared, semi-prepared, or paved.

**Landing Zone Controller**—Individual performing air traffic control duties during LZ operations.

**Landing Zone Safety Officer**—Qualified and certified personnel responsible for safe and efficient conduct of LZ operations. This individual is in charge of the LZ, supervises personnel on/around the LZ and ensures the LZ is usable for the planned operation.

**Lead MAJCOM**—The lead Major Command and focal point for a DAF effort. Normally the Office of Primary Responsibility for applicable Department of the Air Force Instructions, Manuals, Air Force Instructions and Manuals.

**Light Tactical Fixed Wing**—All Mission Design Series smaller than C-130.

**Load Exit Time**—The length of time required for the first through the last object or parachutist to clear the aircraft.

**Local Area**—The area of standard training operations for a given flying unit. Locations and distance from home stations are normally designated by given flying unit.

**Mean Effective Wind**—A theoretical wind of constant velocity and direction, extending from the surface to a predetermined altitude above the ground.

**Military Free Fall**—An employment method encompassing both high-altitude low opening and high-altitude high opening parachuting techniques.

**Military Grid Reference System**—A two-dimensional grid that uniquely identifies a square meter anywhere on the earth. It attempts to represent the entire surface of the Earth on a worldwide grid. It is designed for use with the Universal Transverse Mercator and Universal Polar Stereographic grids.

**Mountainous Area**—An area of changing terrain profile where the changes of terrain elevation exceed 900 meters (3000 feet) within a distance of 18.5 km (10.0 NM). (ICAO).

**Nacelle**—A housing, separate from the fuselage, which holds engines, fuel or equipment on an aircraft (the outer casing of an aircraft engine). Includes the propeller and its arc when used in measurement to vertical obstruction clearances.

**Night**—The time between the end of evening civil twilight and the beginning of morning civil twilight, as published in the American Air Almanac, converted to local time (ref AFMAN 11-202V3).

**Obstruction (or Obstacle)**—A natural or man-made object that violates airfield or heliport clearances, or projects into imaginary airspace surfaces.



**Open Snow**—A planned LC-130 open field LZ that is ungroomed and typically unmarked.

**Operational Control**—The authority to perform those functions of command over subordinate forces involving organizing and employing commands and forces, assigning tasks, designating objectives and giving authoritative direction necessary to accomplish the mission. Also called OPCON.

**Pathfinder**—US Army personnel who have completed the US Army Pathfinder course, trained on HLZ and DZ operations. Army pathfinders mainly provide navigational aid and advisory services to military aircraft in areas designated by supported unit commanders. The pathfinders' secondary missions include providing advice and limited aid to units planning air assault or airdrop operations.

**Permissive Environment**—Operational environment in which host nation military and law enforcement agencies have control, as well as the intent and capability to assist operations that a unit intends to conduct.

**Point of Impact**—The point on the DZ where the first parachutist or airdropped cargo item lands or is expected to land.

**Polar Landing Zone**—A planned LC-130 landing surface that includes skiways, ski landing areas, ice runways, or open-snow areas.

**Raised Angle Marker**—A device used to mark the point of impact during airdrops. A triangular shaped marker constructed of bright orange material, six feet wide at the base (minimum) and six feet high (minimum), displayed at a 60-degree angle into the direction of flight.

**Ram Air Parachute System**—U.S. military parachute systems that use a rectangular multi-cell canopy which is highly maneuverable, has a high glide ratio and is used for military freefall operations. The military equivalent of a High Glide Ratio Parachute.

**Rapidly Rising Terrain**—Any terrain feature not captured as an obstacle or mountainous area that would affect an aircraft's performance of flight within 10 NM of assault zone.

**Release Point**—The point over the DZ where personnel or equipment should exit the drop aircraft.

**Runway Condition Rating**—Numerical decelerometer readings relayed by air traffic controllers at USAF and certain civil bases and/or LZ for use by the pilot in determining runway braking action.

**Safety Zone**—A distance established by agreement between the airlift mission commander and the ground mission commander subtracted from the DZ trailing edge to reduce the potential for off-DZ drops. For peacetime personnel airdrops, the safety zone will never be less than 200 yards. **(T-1)**. Do not compute safety zone distances for high altitude low opening and/or high altitude high opening airdrops.

**Ski Landing Area**—A ski airfield that has reduced flagging from that of a skiway.

**Skiway**—A designated area for LC-130 ski operations marked and maintained in accordance with this manual. Skiways must have a published instrument or visual approach procedure and be located near a surface camp with support facilities to include weather reporting, shelter, first aid, food, communications and grooming on a continual basis. **(T-2)**.

**Skiway Landing Area Control Officer**—An experienced LC-130 pilot or CCT/STO experienced in LC-130 ski operations responsible for certifying a Skiway Landing Area.

**Station Keeping Equipment**—An aircraft avionics system used to maintain formation position in instrument meteorological conditions. When used in conjunction with an adverse aerial delivery system lead aircraft, instrument meteorological conditions airdrops are possible.

**Special Operations Forces**—Active, reserve and guard component forces of the military services designated by the Secretary of Defense, possess a service-level validated requirement and are organized, trained and equipped to conduct and support special operations.

**Special Operations Low Level II**—C-17 aircrews assigned to the 437 OG to fulfill the 437 OGS mission and qualified/certified to utilize Addenda B and 437 OG specified Technical Order procedures.

**Special Warfare**—USAF special operations forces consisting of Special Warfare Officers, CCT, Pararescue, Tactical Air Control Party and Special Reconnaissance personnel who are organized, trained and equipped to establish and control the air-ground interface at an airhead in the objective area. Functions include assault zone reconnaissance and surveillance, establishment and terminal control; combat search and rescue; combat casualty care and evacuation staging; special operations terminal attack; and special reconnaissance.

**Supported Commander**—The commander having primary responsibility for all aspects of a task assigned by a joint planning authority and who prepares operation plans or operation orders in response to requirements. In the context of a support command relationship, the commander who receives assistance from another commander's force or capabilities, and who is responsible for ensuring that the supporting commander understands the assistance required.

**Threshold of Runway**—A line perpendicular to the runway centerline designating the beginning of that portion of the runway usable to determine glide slope ratio for landing. Establishes the reported approach and departure runway elevations.

**Trailing Edge of a Drop Zone**—Represents the imaginary line extending between the left and right rear corners of a surveyed DZ.

**Unilateral**—Describes an AF only operation. A unilateral mission will not be considered a joint operation merely because the parachutists or loads are from another service. **(T-1)**. Example: An DAF reserve airlift unit conducting training airdrop missions using Army paratroopers or when Army paratroopers jump with DAF personnel on a DAF unit's operation.

**Verbally Initiated Release System**—A method of positioning aircraft for airdrop by verbal instruction from the DZ controller.

**Visual Meteorological Conditions**—Weather conditions where visual flight rules apply; expressed in terms of visibility, ceiling height, and aircraft clearance from clouds along the path of flight. When these criteria do not exist, instrument meteorological conditions prevail and instrument flight rules must be followed. **(T-1)**.

**Wind Drift Indicator**—A five to six-foot length of paper (approximately) dropped from an airdrop aircraft to evaluate altitude to surface wind drift prior to an airdrop.

## Attachment 2

## WIND/SEA STATE PREDICTION CHARTS

**A2.1. Wind/Sea State Observation Chart.** Use [Table A2.1](#) to determine the sea state for water DZ airdrops.

**Table A2.1. Wind/Sea State Observation Chart.**

Wind Velocity (Knots)	International Description	Wind Force (Beaufort)	Appearance of Wind Effects on the Water	Appearance of Wind Effects on Land
<1	Calm	0	Sea surface smooth and mirror-like	Calm, smoke rises vertically
1 - 3	Light Air	1	Scaly ripples, no foam crests	Smoke drift indicates wind direction, still wind vanes
4 - 6	Light Breeze	2	Small wavelets; crests glassy no break.	Wind felt on face, leaves rustle, vanes begin to move
7 - 10	Gentle Breeze	3	Large wavelets; crests begin to break; scattered whitecaps.	Leaves and small twigs constantly moving, light flags extended
11 - 16	Moderate Breeze	4	Small waves 1-4ft becoming longer. Numerous whitecaps	Dust, leaves and loose paper lifted, small tree branches move
17 - 21	Fresh Breeze	5	Moderate waves 4-8ft taking longer form; many whitecaps, some spray.	Small trees in leaf begin to sway
22 -27	Strong Breeze	6	Larger waves 8-13 feet, whitecaps common, more spray	Larger tree branches moving, whistling in wires
28 - 33	Near Gale	7	Sea heaps up, 13-19 feet, white foam streaks off breakers	Whole trees moving, resistance felt walking against wind
34 - 40	Gale	8	Moderately high (18-25feet) waves of greater length; edges of crests begin to break into spindrift, foam blown in streaks	Twigs breaking off trees, generally impedes progress
41 - 47	Strong Gale	9	High waves (23-32 feet), dense streaks of foam; sea begins to roll, spray may	Slight structural damage occurs, slate blows off roofs

			reduce visibility.	
Wind Velocity (Knots)	International Description	Wind Force (Beaufort)	Appearance of Wind Effects on the Water	Appearance of Wind Effects on Land
48 - 55	Storm	10	Very high waves (29-41 feet) with overhanging crests, sea white with densely blown foam, heavy rolling, lowered visibility	Seldom experienced on land, trees broken or uprooted, "considerable structural damage"
56 - 63	Violent Storm	11	Exceptionally high (37-52 feet) waves, foam patches cover sea, visibility more reduced	N/A
64 +	Hurricane	12	Air filled with foam, waves over 45 feet, sea completely white with driving spray, visibility greatly reduced	N/A

**A2.2. Summary of Wind Observing Standards.** Use [Table A2.2](#) to determine and report wind data for assault zone operations in accordance with AFMAN 15-111.

**Table A2.2. Summary of Wind Observing Standards Chart.**

DATA	WIND OBSERVING STANDARDS
Wind Direction	2-minute average in 10-degree increments.
Wind Speed	2-minute average in knots.
Wind Gust	The maximum instantaneous speed in knots in the past ten minutes.
Wind Shift	A change in wind direction by 45 degrees or more in less than 15 minutes with sustained winds of ten knots or greater throughout the shift.

## Attachment 3

## STANDARD/METRIC CONVERSION CHART

**A3.1. Standard/Metric Conversion Chart.** Use [Table A3.1](#) for standard conversions.

**Table A3.1. Standard/Metric Conversion Chart.**

<b>STANDARD/METRIC CONVERSION CHART</b>			
<u>Factors for Conversion of Units</u>			
To convert A to B, multiply A by C.			
To convert B to A, multiply B by D.			
<b>UNIT A LENGTH</b>	<b>UNIT C</b>	<b>UNIT D</b>	<b>UNIT B</b>
Statute Miles	5,280.0	0.0001894	Feet
Statute Miles	1.609	0.6214	Kilometers
Nautical Miles	1.1516	0.8684	Miles
Meters	3.281	0.3048	Feet
Kilometers	3,281.0	0.0003048	Feet
Yards	3.0	0.33333	Feet
Inches	2.540	0.3937	Centimeters
Feet	0.1667	6.0	Fathoms
<b>VELOCITIES</b>			
Miles Per Hour (Statute)	1.467	0.6818	Ft. Per Second
Meters Per Second	3.281	0.3048	Ft. Per Second
Meters Per Second	2.237	0.4470	Miles Per Hour (Statute)
Yards/Second	2.355	0.4246	Knots
<b>WEIGHT</b>			
Ounces	0.0625	16.0	Pounds
Pounds	7000.0	0.0001429	Grains
Kilograms	2.205	0.4536	Pounds
Short Tons	2000.0	0.0005	Pounds
Short Tons	0.91	1.0989	Long Tons
Long Tons	1120.0	0.8729	Short Tons
<b>ANGULAR MEASURE</b>			
Circle	360.0		Degrees
Degrees	60.0	0.1667	Minutes
Degrees	17.8	0.056	Mils
Mils	3.27	0.296	Minutes
Minutes	60.0	0.01667	Seconds
<b>TEMPERATURE CONVERSION</b>			
To convert Fahrenheit to Centigrade, subtract 32 degrees and multiply by 5, then divide by 9.			
To convert Centigrade to Fahrenheit, multiply by 9, divide by 5 and add 32 degrees.			

## Attachment 4

### GUIDANCE CONCERNING AF FORM 3823, *DZ SURVEY*

**A4.1. AF Form 3823.** Use Chapters **2**, **3**, and these instructions and sample entries listed below to complete AF Form 3823 in **Figure A4.1**. All blocks require an entry including “N/A” if non-applicable.

#### A4.1.1. **Block 1.**

A4.1.1.1. **Block 1A.** Enter DZ name and type in abbreviated format (i.e., DZ, CDZ, WDZ, CWDZ).

A4.1.1.2. **Block 1B.** Surveys published on Talon Point will have a unique index number automatically generated. Talon Point allows inclusion of AMC index number if utilized. If resurveyed, the existing Talon Point index number established is utilized.

#### A4.1.2. **Block 2.**

A4.1.2.1. **Block 2A.** Spell out the name of the country and use associated NGA Geopolitical Entities Names and Codes (GENC) as identified in either <https://nsgreg.nga.mil/gencc/discovery> or in Talon Point. Talon Point will automatically generate the associated GENC during data entry.

A4.1.2.2. **Block 2B.** Enter the state, province, territory, etc as applicable and use GENC.

A4.1.3. **Block 3.** If available enter map series, sheet number, edition and date of map used. If using imagery or mapping tool enter source and date of imagery and/or mapping collection. If exact date cannot be verified, identify as “estimated.”

#### A4.1.4. **Block 4.**

A4.1.4.1. **Blocks 4A1 through 4A4.** Enter the date survey was conducted, surveyor’s name, grade, service, telephone number and unit of assignment (include home base and location).

A4.1.4.2. **Block 4B.** The surveyor will fill out this item. **(T-1).** Enter approval or disapproval symbol for each drop category by using the letter “A” for approved, and the letter “D” for disapproved. Leave no blank spaces under the preprinted categories.

A4.1.4.3. **Block 4C.** The ground operations approval authority will enter name, grade, service, telephone number and unit of assignment (include home base and location), utilize electronic signature or wet sign. **(T-1).**

A4.1.4.4. **Block 4D.** Safety of flight is in accordance with Chapters **2** and **3**. On all DZ surveys MAJCOM tactics may also complete safety of flight review. Safety of flight representative will enter name, grade, service, telephone number and unit of assignment (include home base and location), utilize electronic signature or wet sign. **(T-1).**

A4.1.4.5. **Block 4E.** Approval is in accordance with Chapters **2** and **3**. Enter the date approved, approver’s name, grade, service, telephone number and unit of assignment (include home base and location). Approving representative will utilize electronic signature or wet sign **(T-1)**. Once approved and signed, the DZ is ready for use and shall be published in accordance with **Chapter 2. (T-1)**.

A4.1.5. **Block 5A through 5E.** Enter the controlling agency responsible for scheduling the DZ to include commercial phone with DSN phone number. If the DZ is within a controlled or monitored area, enter the range control data for that location to include frequencies and commercial phone. If the DZ is not located on government owned property, it may be necessary to obtain a land use agreement or Memorandum of Understanding (MOU). The requesting unit is responsible for obtaining and providing land use agreement and/or MOU. Check the block that applies, and when “yes” is checked, check “attached” and attach a copy of MOU or land use agreement submitted for all approval and safety of flight reviews.

A4.1.6. **Block 6.**

A4.1.6.1. **Block 6A through 6C.** Enter the DZ dimensions using yards and meters. Enter the DZ radius for a circular DZ. Do not put a rectangular and circular survey on the same form.

A4.1.6.2. **Blocks 6D through 6F.** Enter the distance from the leading edge of the DZ to each point of impact using yards and meters. Should use the most restrictive leading edge for approval (e.g., night leading edge more restrictive than day).

A4.1.7. **Blocks 7A through 7D.** Blocks 7A-7C enter the primary DZ axis in magnetic, grid and true north. Block 7D will be the current World Magnetic Model (WMM), and will be used to calculate 7A and all magnetic headings within survey. It is displayed as Source/Year (e.g., GPS/2020). If DZ is circular, enter N/A. List applicable DZ axis restrictions in block 11, remarks. **NOTE:** If surveyor’s device and/or collection application is not using the current WMM, when data is entered in Talon Point, data will be updated to reflect current WMM. Talon Point will continue to update WMM to data on published surveys as WMMs change.

A4.1.8. **Block 8A through 8D.** Enter the elevation in feet mean sea level (MSL) for each point of impact surveyed as well as the highest point on the DZ. Surveyors should check, and adjust when required, all relative elevations collected by GPS against existing verified forms of MSL elevations (e.g., map, DTED, mensurated elevations). **(T-1).** **NOTE:** Relative elevations collected by GPS are accurate to GPS error level when time and satellites are consistent.

A4.1.9. **Block 9.**

A4.1.9.1. **Block 9A.** Enter WGS84 for the spheroid or ellipsoid. Surveyors will only use WGS84 in computing coordinates for the DZ **(T-2).**

A4.1.9.2. **Block 9B.** Enter WGS84 for the datum. Surveyors will only use WGS84 in computing coordinates for the DZ **(T-2).**

A4.1.9.3. **Blocks 9C through 9E.** Enter grid zone, easting and northing obtained from the map, GPS, Talon Point or other source.

A4.1.9.4. **Block 9F.** Place an “X” in the appropriate block.

A4.1.9.5. **Block 9G.** Enter the grid zone designator, grid square identifier and the ten-digit Military Grid Reference System (MGRS) coordinates and elevation. Include a short verbal description of an easily recognized point on or near the DZ (e.g., road intersection, benchmark, pond, etc.) that can be used by the DZ party to find the PIs. Include a distance and azimuth from this point to the nearest surveyed PI.



A4.1.9.6. **Block 9H.** Enter the ten-digit MGRS and latitude/longitude coordinates to the nearest one-thousandth minute for each indicated point.

A4.1.9.7. **Block 9I.** Enter the ten-digit MGRS coordinates referencing datum and spheroid and the WGS84 latitude/longitude coordinates to the nearest one-thousandth minute for each indicated point.

A4.1.10. **Block 10.** Provide a legible, to scale diagram of the DZ including all obstacles or prominent features located within the DZ boundaries and 5 NM from DZ center that could affect ground or flight safety. Annotate the distance these items are from the DZ center in block 11 and depict on the DZ diagram, block 10 to include DZ dimensions. Ensure to annotate all charted or observed water hazards and power lines within 1,000 meters of the DZ boundaries (or 1,000 meters of the MFF PI). Diagram shall be oriented true north and indicated with an arrow. **(T-1).**

A4.1.11. **Block 11.** Include any pertinent comments regarding operations on the DZ. Also include any statements concerning safety in the DZ area (e.g., hazards, towers). Annotate all charted or observed power lines and/or water hazards within 1,000 meters of the DZ boundaries for static line/PI for MFF. **(T-1).** Example remarks and formats can be found in **Figure A4.1.** **NOTE:** this is not a comprehensive list of examples. Not all required. Examples may modified, added or removed to meet requirements.

A4.1.12. **Block 12.** Indicate whether photographs of the DZ are available. If available, surveyor, ground approver (quality control) or safety of flight reviewer will attach photo product(s) with survey submission. **(T-3).** Indicate whether a low-level route is associated with the DZ. Individual completing the safety of flight review should know this information and will ensure accuracy, completeness and mark accordingly. **(T-1).**

**A4.2. Host Nation DZ Surveys.** For review of a HN DZ survey in accordance with **paragraph 3.16.1.2**, validate as much source data as possible for the blocks in the AF Form 3823. At a minimum, safety of flight must review the review the following items: 1A, 2A, 2B, 4D, 6A-B or C, 7, 9, and 11. **(T-1).** Attach a copy of the foreign DZ to the safety of flight review. **NOTE:** AF Form 3823 and tactical DZ surveys conducted in accordance with this this manual by validated RAAF CCT DZ Surveyors certified in accordance with **paragraph 3.16.2** may be used for USAF and USSF operations.

Figure A4.1. AF Form 3823, Drop Zone Survey.

AIRBORNE UNIT ASSUMES RESPONSIBILITY FOR PERSONNEL INJURY AND EQUIPMENT DAMAGE ON DZ										
<b>DROP ZONE SURVEY</b>	1A. DZ NAME			1B. ZAR INDEX NO.			2A. COUNTRY		2B. STATE	
	3. MAP SERIES/SHEET NUMBER/ EDITION/ DATE OF MAP									
<b>4. SURVEY APPROVAL/DISAPPROVAL DATA</b>										
4A1. DATE SURVEYED		4A2. TYPED NAME AND GRADE OF SURVEYOR				4A3. PHONE NUMBER (DSN)		4A4. UNIT		
4B. DROP ZONE APPROVAL/DISAPPROVAL A = APPROVED D = DISAPPROVED	FOR	CDS/CRL/CRS	PER	HE	MFF	SATB	CRRC	HSLADS	HVCDS	
	DAY									
4C. DATE APPROVED FOR GROUND OPERATIONS	NAME, GRADE AND SERVICE OF APPROVAL AUTHORITY				PHONE NUMBER (DSN)		SIGNATURE			
	UNIT AND LOCATION									
4D. DATE SAFETY OF FLIGHT REVIEW APPROVED	NAME AND GRADE OF REVIEWING OFFICER				PHONE NUMBER (DSN)		SIGNATURE			
	UNIT AND LOCATION									
4E. DATE OF MAJCOM APPROVAL	NAME AND GRADE OF APPROVING AUTHORITY				PHONE NUMBER (DSN)		SIGNATURE			
	UNIT AND LOCATION									
<b>5. COORDINATING ACTIVITIES</b>										
A. DZ CONTROLLING AGENCY OR UNIT			B. MEMORANDUM OF UNDERSTANDING/LAND USE YES <input type="checkbox"/> NO <input type="checkbox"/> ATTACHED <input type="checkbox"/>				C. PHONE NUMBER (DSN)			
D. RANGE CONTROL						E. PHONE NUMBER (DSN)				
<b>6. DZ DIMENSIONS (YDS/MTRS) (FOR CIRCULAR DZ, ENTER RADIUS ONLY)</b>										
A. LENGTH			B. WIDTH			C. RADIUS				
POINT OF IMPACT DISTANCES FROM DZ LEADING EDGE			D. CDS PI		E. PE PI		F. HE PI			
<b>7. DZ AXIS DATA (OPTIONAL FOR CIRCULAR DZ)</b>										
A. MAGNETIC		B. GRID (MGRS)			C. TRUE		D. SOURCE/DATE OF VARIATION DATA			
B. GROUND POINT ELEVATION	A. CDS PI		B. HE PI		C. PE PI		D. HIGHEST			
<b>9. DZ COORDINATES</b>										
A. SPHEROID		B. DATUM		C. GRID ZONE		D. EASTING		E. NORTHING		
F. GPS DERIVED COORDINATES YES <input type="checkbox"/> NO <input type="checkbox"/>			G. POINT OF ORIGIN							
H. POINT	MGRS COORDINATES			WGS84 LATITUDE (D-MMM)			WGS84 LONGITUDE (D-MMM)			
DZ CENTERPOINT										
CDS PI										
PE PI										
HE PI										
<b>I. DZ CORNERS MGRS COORDINATES</b>										
LEFT LEADING EDGE					RIGHT LEADING EDGE					
LEFT TRAILING EDGE					RIGHT TRAILING EDGE					

DZ NAME	
10. DZ DIAGRAM	
See Attached Diagram	
11. REMARKS	
<ol style="list-style-type: none"> <li>1. Coordinates and elevation data derived from GPS, maintained horizontal margin of error +/- "xx" meters, (use least accurate when collecting data) Vertical margin of error 1.5 X horizontal error. MAGVAR = "x.x°"E/W/changing "x.x"°E/W per year/derived from "WMM 20xx" as of date surveyed.</li> <li>2. Administration/Coordination/Planning/Scheduling Instructions:</li> <li>3. Obstacles/Hazards: (Distances/magnetic headings from DZ center point)                  INSIDE DZ:                 <ol style="list-style-type: none"> <li>a. e.g., 25' Windsock 15' @ 225° from DZ center point.</li> <li>b. e.g., For parachutist flotation requirements, see ATP 3-18.11, TC 18-11 and AFMAN 11-420, for minimum safety boat and swimmer requirements see AFI 10-3503.</li> </ol>                 OUTSIDE DZ:                 <ol style="list-style-type: none"> <li>a. e.g., 40' Trees border East, South and West borders of DZ.</li> <li>b. CAUTION: 60' Power line 600m @ 330°. Oriented N-S. Power lines can or cannot be turned off – Jumpmaster &amp; aircraft CC must both authorize and brief to teams status of power lines. <b>(T-2)</b>.</li> <li>c. e.g., hilltop est. 2 NM north, elev. Unknown</li> <li>d. e.g., crevasse system 1.5 NM south running east-west</li> </ol> </li> <li>4. Safety of Flight Review:                 <ol style="list-style-type: none"> <li>a. SOF Review Reported Obstacles/Hazards (including terrain) within 5 NM                      Radius of the DZ Center point:                     <ol style="list-style-type: none"> <li>1) North (315° – 045° T): x/MSL/NM</li> <li>2) East (045° – 135° T): x/MSL/NM</li> <li>3) South (135° – 225° T): x/MSL/NM</li> <li>4) West (225° – 315° T): x/MSL/NM</li> </ol> </li> <li>b. Additional Information and Airspace:                     <ol style="list-style-type: none"> <li>i. Xxx are located within a 10 NM Radius of the DZ Center point.</li> </ol> </li> </ol> </li> <li>5. Notes:                 <ol style="list-style-type: none"> <li>a. e.g., Information that does not fit in any other areas.</li> <li>b. Example A/R: Random Run-ins approved for MFF operations unless otherwise directed by ATC.</li> </ol> </li> <li>6. Example A/R, JPADS Remarks:                 <ol style="list-style-type: none"> <li>a. DZ meets JPADS criteria for Day/Night operations – Approved ADE is required prior to operations.</li> <li>b. RPI's can be used. Coordinates/Elevations will be passed for ADE approval prior to</li> </ol> </li> </ol>	
12. PHOTOGRAPH AVAILABLE YES <input type="checkbox"/> NO <input type="checkbox"/>	LOW LEVEL ROUTES <input type="checkbox"/> NONE AVAILABLE <input type="checkbox"/> ROUTE NAME/DESIGNATOR



## Attachment 5

## GUIDANCE CONCERNING AF FORM 3822, LZ SURVEY

**A5.1. AF Form 3822.** Use Chapters 2, 4, and these instructions and sample entries listed below to complete the AF Form 3822 in **Figure A5.1**. All blocks require an entry including “N/A” if non-applicable. **NOTE:** Use AF Form 3822 in this attachment. Changes to AF Form 3822 prior to this publication are due to errors and updates required to be in accordance with this DAFMAN.

**A5.1.1. Block 1 .**

**A5.1.1.1. Block 1A.** Enter LZ name and type in abbreviated format (i.e., LZ, LTFW LZ).

**A5.1.1.2. Block 1B.** Talon Point will automatically generate a unique index number for published surveys. Talon Point allows inclusion of the AMC index number if requested. If this is a resurvey, use the existing Talon Point index number.

**A5.1.2. Block 2.**

**A5.1.2.1. Block 2A .** Spell out the name of the country and use associated GENC as identified in either <https://nsgreg.nga.mil/genc/discovery> or in Talon Point. Talon Point will automatically generate the associated GENC during data entry.

**A5.1.2.2. Block 2B .** Enter the state, province, territory, etc as applicable and use GENC.

**A5.1.3. Block 3.** If available enter map series, sheet number, edition and date of map used. If using imagery or mapping tool enter source and date of imagery and/or mapping collection.. If exact date cannot be verified identify as “estimated.”

**A5.1.4. Block 4.**

**A5.1.4.1. Block 4A.** Enter the date survey was conducted. Enter the lead surveyor’s (7/9 level) name grade, service, telephone number and unit of assignment (include home base and location). If lead surveyor is different than the surveyors who collected the data, annotate lead data collecting surveyor information in remarks).

**A5.1.4.2. Block 4B.** Safety of flight is in accordance with Chapters 2 and 4. On all LZ surveys MAJCOM tactics may also complete safety of flight review. Safety of Flight reviewer will enter name, grade, service, telephone number and unit of assignment (include home base and location), and utilize electronic signature or wet sign. **(T-1).**

**A5.1.4.3. Block 4C.** Approval is in accordance with Chapters 2 and 4. Enter the date approved, approver’s name, grade, service, telephone number and unit of assignment (include base and location). Check either “Approved” or “Disapproved.” Approving representative will utilize electronic signature, or wet sign. **(T-1).** Once approved and signed, the LZ is ready for use and shall be published in accordance with **Chapter 2. (T-1).**

**A5.1.5. Block 5.** Enter the information for the LZ controlling agency. If the LZ is within a controlled or monitored area, enter the primary and alternate LZ control frequency and range control frequency. If LZ is not within a controlled or monitored area, enter established/approved primary and alternate frequencies. If the LZ is not located on government owned property, it may be necessary to obtain a land use agreement or MOU. This is the responsibility of the requesting unit. Check the block that applies and attach a copy of

memorandum or land use agreement if applicable. Enter commercial phone numbers for each followed by the DSN prefix in parenthesis.

A5.1.6. **Block 6.** Enter runway length from primary approach threshold to primary departure threshold with units of measure in feet. Length does not include overruns when they exist. Runway Width for operational LZ evaluation and use does not have shoulders, but shoulders and graded area are required for construction evaluation. **NOTE:** AF Form 3822 may be utilized for evaluations of new LZ construction; when utilized, enter data for graded area and shoulders in blocks “B-Zone” and “A-Zone” respectively. List the zone A and B width distance utilized for evaluation. Measure zone A width from edge of useable runway and zone B from edge of zone A. (For new LZ construction evaluation surveys utilizing C-130/C17 criteria only; enter data for graded Area in “B-Zone” and shoulders in “A-Zone”).

A5.1.7. **Blocks 7A through 7D.** Enter the primary runway run-in heading/reciprocal in magnetic, grid and true north, and include Source and Date of variation data. Block 7D will be the current WMM, and will be used to calculate 7A and all magnetic headings within survey. It is displayed as Source/Year (e.g., GPS/2020). **NOTE:** If surveyor’s device/collection application is not using the current WMM, when data is entered in Talon Point, data will be updated to reflect current WMM. Talon Point will continue to update WMM to data on published surveys as WMMs change.

A5.1.8. **Block 8A through 8C.** Enter the elevation in MSL for each location surveyed. 8A/B are the primary approach/departure thresholds, 8C is the highest elevation on the runway. Surveyors should check, and adjust when required, all relative elevations collected by GPS against existing verified forms of MSL elevations (e.g., map, DTED, mensurated elevations). **NOTE:** Relative elevations collected by GPS are accurate to GPS error level when time and satellites are consistent.

A5.1.9. **Block 9.**

A5.1.9.1. **Block 9A.** Enter WGS84 for the spheroid or ellipsoid and datum. Surveyors will only use WGS84 in computing coordinates for the LZ. **(T-2).**

A5.1.9.2. **Block 9B.** Place an “X” in the appropriate block.

A5.1.9.3. **Block 9C through 9E.** Enter grid zone, easting and northing obtained from the map, GPS, Talon Point or other source.

A5.1.9.4. **Block 9F-H.** Enter the grid zone designator, grid square identifier and the ten-digit MGRS coordinates in WGS84 datum/spheroid or ellipse, latitude and longitude to the nearest one-hundredth minute for the LZ center point, runway approach end (primary approach threshold), departure end (primary departure threshold), LZ center point. LZ center point is the mid-point between the runway approach/departure End of Usable.

A5.1.10. **Block 10.**

A5.1.10.1. **Blocks 10A.** Enter the type of LZ surface. For semi-prepared utilize Unified Soil Classification System standard word format (e.g., sand, clay, silt, gravel, or silty sand) and in accordance with TSPWG M 3-260-03.02-19. If a paved surface, state Asphalt or Portland Cement Concrete and specify the thickness of asphalt or concrete. If concrete add flexural strength of concrete, use 700 stateside or good quality control and 600 for uncertain quality control (e.g., 6" Asphalt or 12" Portland Cement Concrete (700)). **NOTE:** If greater



expertise is required by unit commands, contact and fund the US Army Corps of Engineers Reachback Operations Center (UROC) by email at [uroc@usace.army.mil](mailto:uroc@usace.army.mil) to send soil samples for laboratory analysis or to set up the *AFSOC-ERDC Soils Training Course* (e.g., training and equipment for the deliberate soils analysis method or classification of soils where freezing temperatures occur).

A5.1.10.2. **Block 10B.** For semi-prepared and unprepared LZ, enter the controlling soil strength profile reading to include thickness and corresponding CBR of layers. Identify the controlling layer. Take strength tests to a minimum depth of 24-inches for the C-130 (and LTFW) and 36-inches for the C-17. Example: Surface: 7" CBR 14 (controlling layer)/ Subbase: 10" CBR 20/ Subgrade: CBR 45. Additionally, in block 14, remarks, enter the soil strength profile's largest supportable type of aircraft (minimum), the corresponding allowable load/WBC and allowable passes. Additional aircraft may be entered. Example: C-17: 486K & 60 passes / C-130: 175K & 200 passes. When C-17 is the largest suitable aircraft enter the C-130 data as well. Use evaluation criteria of 1000 passes and max aircraft weight first to evaluate and report allowable load/WBC and allowable passes, (e.g., criteria provides the evaluation criteria beyond an initial surge and provides allowable loads to sustain aircraft throughout the anticipated operation of the LZ). If mission requirement cannot be met and the requirement is to support an initial surge of mission aircraft then use expedient evaluation criteria of 100 passes and max aircraft weight for evaluation of WBC & allowable passes, (e.g., allowable loads increase while sustained operational capabilities of the LZ reduce). **NOTE:** Also within remarks, report any surveyed semi-prepared and unprepared taxiway(s) and apron(s) respective data for each feature in the same format as runway is reported to include soil strength profile. For paved LZ enter PCN based on a C-17, at 585K at 50,000 passes using shattered slab failure criteria. Paved (asphalt or concrete) example: PCN 42/R/B/X/T. Paved concrete shall not be evaluated as semi-prepared. **(T-1)**. If it is paved asphalt (e.g., flexible), and the evaluated PCN does not meet operational requirement to support aircraft intended for use, it may be evaluated as semi-prepared based on semi-prepared evaluation criteria to support mission requirements in accordance with [paragraph 4.3.1.2.3](#) When asphalt LZ is evaluated as semi-prepared list the PCN and semi-prepared strength information together. Paved asphalt evaluated as semi-prepared example: PCN 14/F/A/W/T, C-17: 486K & 12,611 passes / C-130: 175K & 74,366 passes. Also, within remarks, report soil strength profile and any surveyed paved taxiway(s) and apron(s) respective data for each feature in the same format as runway is reported. When paved concrete (e.g., rigid) PCN results yield unusable PCN or ACN/PCN ratio is questionable then evaluate the allowable gross weights and/or allowable pass calculation to determine structural suitability. Evaluate the airfield capability based upon mission requirements and compute allowable pass levels. List new evaluation criteria in remarks. Example evaluation criteria: C-130: 175K & 5000 Passes, C-130: 155K & 1000 passes, C-130: 135K & 250 Passes. List resulting allowable load and passes based off evaluation criteria in remarks as they need to be correlated with evaluation criteria. Surveyors using the evaluation criteria may report all results or just the one result that is most usable. Additionally, in block 14, remarks, for rigid paved LZ (i.e., concrete), enter the controlling strength profile reading to for rigid pavement the same as semi-prepared, but for rigid include thickness and corresponding K-values of layers. Identify the controlling layer as the layer with lowest effective K-value. Take strength tests to a



minimum depth of 24-inches for the C-130 (and LTFW) and 36-inches for the C-17. Example: Concrete: 10" / Base: 12" K 477 / Subgrade: K 289 (Effective K 330).

A5.1.11. **Block 11.** Use two digit runway designators based on primary/reciprocal headings listed in 7A for 11A and 11B.

A5.1.11.1. **Block 11A.** Enter the runway designation and evaluated GSR for a runway based on primary approach/departure threshold derived by the most restrictive obstacle to air navigation within the controlling region. Enter for both runways, primary first. If glideslope is less restrictive than 99:1, list as "unrestricted" and do not report controlling obstacle in block 12I.

A5.1.11.2. **Block 11B.** Enter the percentage of slope for the longitudinal gradient on the primary runway. Use "+" for upslope and "-" for downslope. If an effective gradient exists, enter in lieu of standard longitudinal gradient.

A5.1.12. **Block 12 .**

A5.1.12.1. **Blocks 12A – 12H.** For primary runway enter average percentage of slope for the cross section gradient areas. List left and right runway values from centerline to each edge. Use "+" for upslope and "-" for downslope. For left/right A zones and left/right B zones, enter either "Unobstructed" or "Obstructed, See Remarks" if hazards exist within either or both (e.g., objects, berms, vegetation). Zones A and B require vertical obstruction analysis in accordance with [Table 4.2](#) Gradient chart attachments are not required. **(T-1)**. As applicable, when vertical clearance or gradient hazards exist on surveyed taxiway(s) and/or apron(s), report within blocks A and E and include "See Remarks." and include pertinent data in block 14. **NOTE:** AF Form 3822 may be utilized for evaluations of new LZ construction; when utilized, enter data for maintained areas in 12A/E, for graded Areas in 12B/F, and shoulders in 12C/G) and note each respective surveyed location. Gradient chart data may be collected for LZ construction evaluations and attached if requested for approval.

A5.1.12.2. **Block 12I.** Enter end of overrun/end of usable coordinates for both runways. When any obstacle penetrations to GSRs exist, list the individual controlling obstacle penetration within the controlling region and its relation to relative primary runway threshold based on GSR reported in block 11A. When surveyed for and required, also list displaced threshold(s) using standard example penetrations below. End of overruns are the last point at which an aircraft can taxi or turn on safely. End of Useable is referenced when no overrun exists or is required. List any existing hazardous obstacle penetrations that exist within reportable regions to runway thresholds within block 14, remarks.

**Table A5.1. Standardized example penetrations (not all below may be required or listed).**

- |  |
|--|
| <p>1. End of Usable: (Required, farthest points on runway and overrun surface, taxi/turn suitable)</p> <p>a. Rwy xx: MGRS xxx xx xxxxx xxxxx/LL: xxx° xx.xxx' N/S xxx° xx.xxx' E/W / Elev: xx' MSL</p> <p>b. Rwy xx: MGRS xxx xx xxxxx xxxxx/LL: xxx° xx.xxx' N/S xxx° xx.xxx' E/W / Elev: xx' MSL</p> |
|--|

2. Runway Controlling Obstacles (CO): (if required)
- a. Rwy xx CO: xx' (obstacle type) AGL, xxxx' Distance/xxx' Height = GSR xx:1
  - b. Rwy xx CO: xx' (obstacle type) AGL, xxxx' Distance/xxx' Height = GSR xx:1
3. Displaced Threshold (DT): (as required)
- a. Runway xx DT: xxxx' Displaced/xxxx' Remaining/GSR xx:x
    - 1) MGRS xxx xx xxxxx xxxxx/LL: xxx° xx.xxx' N/S xxx° xx.xxx' E/W/Elev: xxxx'
    - 2) Controlling Obstacle: xx' (obstacle type) AGL, xxxx' Distance/xxx' Height = GSR xx:1
  - b. Runway xx DT: xxxx' Displaced/xxxx' Remaining/GSR xx:x
    - 1) MGRS xxx xx xxxxx xxxxx/LL: xxx° xx.xxx' N/S xxx° xx.xxx' E/W/Elev: xxxx'
    - 2) Controlling Obstacle: xx' (obstacle type) AGL, xxxx' Distance/xxx' Height = GSR xx:1

A5.1.13. **Block 13.** Provide a legible, to scale diagram of the LZ including all obstacles, obstructions and prominent features located within the LZ boundaries. Annotate the distance these items are from the LZ in block 14, remarks, or depict on the LZ sketch. Runways, taxiways and aprons will have dimensions. **(T-1).** Thresholds/displaced thresholds and controlling obstacles will be marked and labeled. **(T-1).** Diagram shall be oriented true north and indicated with an arrow. **(T-1).**

A5.1.14. **Block 14.** Include pertinent, detailed and specific comments, (and data as required), regarding operations on the LZ, (e.g., strength evaluation criteria and controlling reading/layer, abnormalities, such as loose soil on the surface level and penetrating depth to the hard layer below, unusable LZ surfaces, such as unsuitable portions or entire runways, taxiways, or aprons for air operations without a waiver, or specific operating procedures, such as for ground or air users). Also include any statements concerning safety in the LZ area (e.g., hazards, towers, etc.). Remarks that affect performance of flight/safety that can be visibly displayed should be annotated in diagram. Example remarks and formats can be found in [Figure A5.1](#). **NOTE:** this is not a comprehensive list of examples. Not all required. Examples may modified, added or removed to meet requirements.

A5.1.15. **Block 15.** Indicate appropriately whether photographs of the LZ are available. If available, surveyor/quality control/safety of flight reviewer will attach photo product(s) with survey submission **(T-3)**. Indicate whether a low level route is associated with the LZ. Individual completing the safety of flight review should know this information and will mark accordingly. **(T-1).**

**A5.2. Host Nation LZ Survey.** Host Nation LZ surveys may not be used for USAF and USSF air land operations. However, AF Form 3822 and tactical LZ surveys conducted in accordance with this this manual by validated RAAF CCT LZ Surveyors certified in accordance with [paragraph 4.10.5](#) may be used for USAF and USSF operations. Host Nation LZ surveys may be utilized source data by certified LZ surveyors to validate and generate AF Form 3822 or tactical LZ surveys to be submitted for review and approval in accordance with this manual.

Figure A5.1. AF FORM 3822, *Landing Zone Survey*.

<b>LANDING ZONE SURVEY</b>	1A. LZ NAME	1B. ZAR INDEX NO.	2A. COUNTRY	2B. STATE
	3. MAP SERIES/SHEET NUMBER/EDITION/DATE OF MAP			
<b>4. SURVEY APPROVAL/DISAPPROVAL DATA</b>				
4A. DATE SURVEYED	TYPED NAME AND GRADE OF SURVEYOR	PHONE NUMBER (DSN)	UNIT	
4B. DATE REVIEWED	TYPED NAME AND GRADE OF REVIEWER	PHONE NUMBER (DSN)	SIGNATURE	
	UNIT AND LOCATION			
4C. DATE	TYPED NAME AND GRADE OF APPROVING AUTHORITY	PHONE NUMBER (DSN)	SIGNATURE	
APPROVED <input type="checkbox"/> DISAPPROVED <input type="checkbox"/>	UNIT AND LOCATION			
<b>5. COORDINATING ACTIVITIES</b>				
LZ CONTROLLING AGENCY OR UNIT			PHONE NUMBER (DSN)	
RANGE CONTROL			PHONE NUMBER (DSN)	
<b>6. LZ DIMENSIONS (FEET)</b>				
LENGTH	WIDTH	APPROACH END OVERRUN LENGTH	DEPARTURE END OVERRUN LENGTH	
LEFT B-ZONE	LEFT A-ZONE	RIGHT B-ZONE	RIGHT A-ZONE	
<b>7. LZ AXIS DATA</b>				
A. MAGNETIC	B. GRID (UTM)	C. TRUE	D. SOURCE/DATE OF VARIATION DATA	
8. GROUND POINT ELEVATION FOR RUNWAY	A. APPROACH END	B. DEPARTURE END	C. HIGHEST	
<b>9. LZ COORDINATES</b>				
A. SPHEROID/DATUM	B. GPS DERIVED <input type="checkbox"/> YES <input type="checkbox"/> NO	C. GRID ZONE	D. EASTING	E. NORTHING
F. LZ CENTER-POINT	MGRS COORDINATES	WGS84 LATITUDE (D-MMM)	WGS84 LONGITUDE (D-MMM)	
G. APPROACH END	MGRS COORDINATES	WGS84 LATITUDE (D-MMM)	WGS84 LONGITUDE (D-MMM)	
H. DEPARTURE END	MGRS COORDINATES	WGS84 LATITUDE (D-MMM)	WGS84 LONGITUDE (D-MMM)	
<b>10. LZ SURFACE DATA</b>				
A. SURFACE	B. SOIL STRENGTH PROFILE			
<b>11. LZ LONGITUDINAL PROFILE</b>				
A. GUIDE SLOPE RATIO		B. LONGITUDINAL RUNWAY GRADIENT		
<b>12. TRANSVERSE SECTION GRADIENTS</b>				
A. ADDITIONAL A/R	B. LEFT B-ZONE	C. LEFT A-ZONE	D. LEFT HALF RUNWAY	
E. ADDITIONAL A/R	F. RIGHT B-ZONE	G. RIGHT A-ZONE	H. RIGHT HALF RUNWAY	
I. PENETRATIONS				

LZ NAME
13. LZ DIAGRAM
See Attached Diagram
14. REMARKS
<ol style="list-style-type: none"> <li>1. Coordinates and elevation data derived from GPS, maintained horizontal margin of error +/- "xx" meters, (use least accurate when collecting data) Vertical margin of error 1.5 X horizontal error. MAGVAR = "x.x"°E/W/changing "x.x"°E/W per year/derived from "WMM 20xx" as of date surveyed.</li> <li>2. Administration/Coordination/Planning/Scheduling Instructions:</li> <li>3. Surveyor Observed Obstacles/Hazards on and around the LZ. Note: User or LZSO are responsible for identifying/ confirming ALL obstacles/hazards prior to conducting operations:</li> <li>4. INSIDE LZ Obstacles/Hazards:  All obstacles/hazards are in relation from primary rwy threshold and left or right of rwy edge (e.g., 10' tall tree/+2400'/L 30', 7" pole/-150'/R 24').  A-zones: None. (or example: 6" tall metal pipe/+350'/L 10')  B-zones: None. (or example: 2' tall berms/entire length/L and R 40')</li> </ol> <p>Surface condition at time of survey:  RWYxx/xx: site survey time/date: xxxxx 20xx  RCR: xx  Semi-Prepared Airfield Inspection (SPACI) Overall Rating xx =  (Green/Amber/Red)  Distress Potholes: None  Distress Ruts: None</p> <p>Aggregate:  Coverage: (Examples: Red/Covers &gt; 1/2)  Size: (Green/3/4" or Less)</p> <p>Dust: (Green/Does not obstruct visibility)  Rolling Resistance Material: None  Jet Blast Erosion: None  Stabilized Layer Failure: None  Taxiway x, width: xx.  (Same as above if surveyed, specify primary txy direction based on primary runway)  Apron x, length and width: xxx x xxx.  (Same as above if surveyed, specify edges for hazards/obstacles)</p>

OUTSIDE LZ Obstacles/Hazards:

e.g., 25' Windsock 1641' @ 225° from Rwy xx Approach, 354' left or right of Rwy xx Centerline.

1. Safety of Flight Review:
  - a. SOF Review Reported Obstacles/Hazards (including rapidly rising/high terrain) within 5 NM Radius of the HLZ Center point:
    - i. North: e.g., multiple towers, buildings, high terrain and smokestacks.
    - ii. South: e.g., rapidly rising terrain @ 0.2 NM,
  - b. Additional Information and Airspace:
    - i. XXX are located within a 10 NM Radius of the LZ center point.
2. Notes:
  - a. E.g., Information that does not fit in any other areas.
  - b. Apron locations with lengths and widths. e.g., obstacles/hazards.
  - c. Taxiway locations with lengths and widths. e.g., obstacles/hazards.
3. Runway strength evaluation:
  - a. Number of tests conducted, type device, depth of readings, e.g., 10 DCP readings taken to a depth of 36 inches.
  - b. Aircraft: WBC & allowable passes, e.g., C-17: 486K & 60 passes / C-130: 175K & 200 passes.

**Note:** Include "4. Taxiway" and "5. Apron" if surveyed, apply soil strength profile and strength evaluation format.

4. Taxiway strength evaluation:
  - a. xx "DCP" or "ACP" readings taken to a depth of "24" or "36" inches.
  - b. Surface: xx" CBR xx / Subbase: xx" CBR xx/Subgrade: CBR xx (Identify the controlling layer)
  - c. x-xx: xxxK & xx passes
5. Apron strength evaluation:
  - a. xx "DCP" or "ACP" readings taken to a depth of "24" or "36" inches.
  - b. Surface: xx" CBR xx / Subbase: xx" CBR xx/Subgrade: CBR xx (Identify the controlling layer)
  - c. x-xx: xxxK & xx passes

## 15. PHOTOGRAPHY AVAILABLE

YES     NO

## LOW LEVEL ROUTES

NONE AVAILABLE  
 ROUTE NAME/DESIGNATOR





## Attachment 6

### GUIDANCE CONCERNING AF FORM 4303, *HLZ SURVEY*

**A6.1. AF Form 4303.** Use Chapter 2, 5, and the instructions and sample entries listed below to complete AF Form 4303 in Figure A6.1. All blocks require an entry, including “N/A” if non-applicable. If the block does not provide enough space, enter “See Remarks” and add the required data in block 9. Minimum tactical HLZ Survey information to include is indicated by an asterisk (\*).

#### A6.1.1. Block 1.

A6.1.1.1. **Block 1A\***. Enter HLZ name and type in abbreviated format “HLZ”. Do not change in assessment or update. For tactical HLZ, send HLZ name and “HLZ”.

A6.1.1.2. **Block 1B.** Surveys published on Talon Point will have a unique index number automatically generated. If resurvey or assessment, the existing Talon Point index number established is utilized.

#### A6.1.2. Block 2.

A6.1.2.1. **Block 2A.** Spell out the name of the country and use associated GENC as identified in either <https://nsgreg.nga.mil/genc/discovery>. Or in Talon Point. Talon Point will automatically generate the associated GENC during data entry. **A6.1.2.2 Block 2B.** Enter the state, province, territory, etc as applicable and use GENC. Do not change in assessment or update.

A6.1.3. **Block 3.** If available, enter the map series, sheet number, edition and date of map used. If using imagery or mapping tool enter source and date of imagery and/or mapping collection. May be changed in assessment or update. If exact date cannot be verified identify as “estimated.”

#### A6.1.4. Block 4.

A6.1.4.1. **Block 4A.** Enter the date the original survey was conducted, and surveyor’s name, grade, telephone number and unit of assignment, (include home base and location). Do not change in assessment or update.

A6.1.4.2. **Block 4B.** Enter the date the survey was reviewed, reviewer's name, grade, telephone number, unit and location and signature. The reviewer, in order of preference, is chief (or flight commander) of unit tactics, assistant operations officer, squadron operations officer (or the office designated by MAJCOM supplement) or AC. Safety of flight reviewer will enter name, grade, service, telephone number and unit of assignment (include home base and location), and utilize electronic signature or wet sign. May not be changed in assessment or update.

A6.1.4.3. **Block 4C.** Enter the date the survey was approved or disapproved and approver’s name, grade, telephone number, unit of assignment and signature. Approval is in accordance with Chapters 2 and 5. Enter the date approved, approver’s name, grade, service, telephone number, and unit of assignment (include base and location). Check either “Approved” or “Disapproved.” Approving representative will utilize electronic signature



or wet sign. Do not change in assessment or update. Once signed, HLZ is ready for use and shall be published in accordance with **Chapter 2. (T-1)**.

**A6.1.5. Blocks 5A and 5B.** Enter the controlling agency responsible for scheduling the HLZ. If the HLZ is within a controlled or monitored area, enter the range control data for that location. If the HLZ is not located on government owned property, it may be necessary to obtain a land use agreement or MOU. This is the responsibility of the requesting unit. If applicable, attach the land use agreement and/or MOU to the survey when it is submitted to the unit or agency responsible for scheduling the HLZ (if applicable). May change in assessment or update.

**A6.1.6. Blocks 6A through 6D.** \* Blocks 6A-6C enter the HLZ geometric long axis in magnetic, grid and true North. Block 6D will be the current WMM, and will be used to calculate 6A and all magnetic headings within survey. It is displayed as Source/Year (e.g., GPS/2020). If HLZ is circular, enter N/A. List applicable quadrant and/or recommended HLZ approach/departure magnetic headings in block 9, remarks. **NOTE:** If surveyor's device/collection application is not using the current WMM, when data is entered in Talon Point, data will be updated to reflect current WMM. Talon Point will continue to update WMM to data on published surveys as WMMs change. Only block 6A and 6D may change in the assessment and/or update to correct for yearly change in magnetic variance. Block 6B-6C may not change in assessment or update. For Tactical HLZ, send only primary HLZ run-in heading if determined, (6A), in either magnetic or cardinal direction.

**A6.1.7. Block 7.**

**A6.1.7.1. Block 7A.** Enter WGS84 for the spheroid or ellipsoid and datum Surveyors will only use WGS84 in computing coordinates for the HLZ

**A6.1.7.2. Block 7B.** Place an "X" in the appropriate box. May not be changed in assessment or update.

**A6.1.7.3. Blocks 7C through 7E.\*** Take coordinates from the center point of the HLZ. Enter grid zone designator and grid square identifier obtained from the map, GPS, Talon Point or other source. May not be changed in assessment or update. For tactical HLZ, send only grid zone and coordinates in MGRS or L/L (7C/F).

**A6.1.7.4. Block 7F.\*** Enter the ten-digit MGRS coordinates in WGS84 datum/spheroid or ellipse, latitude and longitude to the nearest one-hundredth minute for the HLZ center point. For tactical HLZ, send only grid zone and coordinates in MGRS or L/L (7C/F).

**A6.1.8. Block 8.** Enter dimensions of the HLZ in feet of long axis by short axis (e.g., 480 x 220 feet). For circular HLZ enter radius. The dimensions of the HLZ describe the portion that has been surveyed. Areas outside the described HLZ dimensions are not surveyed or approved for landing or alternate insertion/extraction.

**A6.1.8.1. Block 8A.** For rectangular or square HLZ, enter length in feet and label in feet. For circular HLZ, enter radius in feet labeling in feet and labeling radius (e.g., 150 feet radius). Recommended to also enter length/radius in meters.

**A6.1.8.2. Block 8B.** For rectangular or square HLZ enter width in feet and label in feet. For circular HLZ enter "N/A" as the radius will already be entered in block 8A. Recommended to also enter width in meters.

A6.1.8.3. **Block 8C.** Enter elevation in feet MSL taken from the HLZ center point. Surveyors should check, and adjust when required, all relative elevations collected by GPS against existing verified forms of MSL elevations (e.g., map, DTED, mensurated elevations).

A6.1.8.4. **Block 8D.** Select quantity and type of aircraft that meet dimensional requirements, based upon either largest aircraft or primary aircraft projected for HLZ use. Other aircraft may utilize HLZ even though they are not listed in quantity and type as long as they meet their minimum dimensional requirements for mission.

A6.1.8.4.1. Reference Figures **A6.1** through **A6.5** for minimum HLZ training dimensions.

A6.1.8.4.2. For multi-ship training operations, multiply single-ship dimensions by the number of aircraft to determine HLZ capacity.

A6.1.8.4.3. For contingency operations reference Figures **A6.1** through **A6.5** Contingency data for minimum HLZ dimensions.

A6.1.8.5. **Block 8E.** Quadrant obstructed or unobstructed.

A6.1.8.5.1. Enter “Unobstructed” if all quadrants have a GSR of 7:1 (8.13°, 14.29%) or greater from the most restrictive controlling obstacle(s) to center of HLZ. **NOTE:** GSR is calculated distance over rise.

A6.1.8.5.2. Enter “Obstructed, see remarks” if any quadrant(s) have a GSR less than 7:1 (8.13°, 14.29%) from the most restrictive controlling obstacle to center of HLZ. List quadrants’ obstruction(s) in block 9. Include in each obstructed quadrant; Obstruction height (in relation to height of HLZ center), name of controlling obstacle, distance from controlling obstacle to center of HLZ in feet and the GSR and/or deg. Illustrate those obstructions in diagram/block 10.

A6.1.8.6. **Block 8F.** Enter degrees of slope based on surveyed geometric long axis, (block 6A-C). **NOTE:** For circular HLZ list surveyed geometric axis utilized for slope, in addition to slope data. Enter upslope as "+"; enter downslope as "-". Enter the HLZ right slope (right is 90° right from axis) in the same manner. For example, a “+2° right -0.5°”, HLZ indicates a positive 2° upslope and a negative 0.5° right downslope on the surveyed geometric long axis.

A6.1.8.6.1. UH-1 slope limits: Ten degrees. (TH-1 restricted to seven degrees nose down).

A6.1.8.6.2. CV-22 slope limits: Nine degrees.

A6.1.8.6.3. HH-60 slope limits: Six degrees nose-down, 15° degrees nose-up, 15° degrees left/right. Aircrew will subtract 2 degrees from each limit for each five knots of wind. **(T-2).**

A6.1.8.6.4. MH-139 slope limits: Ten degrees.

A6.1.9. **Block 9.\*** Enter HLZ surface conditions (e.g., grass asphalt, fine dust, etc.). Exercise extreme care to document the possibility of brown or white out conditions, blowing grass, or any other flying debris that may restrict visibility or damage aircraft or personnel. Enter other hazards and remarks as required. For tactical HLZ, send hazards at a minimum if they exist.

Though no inherent restrictions apply, the standard for communicating general vertical hazards to HLZ air navigation within remarks is by listing the following in each of four cardinal quadrants based on magnetic north; “Quadrant Controlling Obstacle: GSR 9:1 or less = Obstructed/GSR 10:1 or more Unobstructed.” Example remarks and formats can be found in [Figure A6.1](#). **NOTE:** this is not a comprehensive list of examples. Not all required. Examples may be modified, added or removed to meet requirements.

A6.1.10. **Block 10.** Provide detailed diagram of the HLZ. Diagram will be to scale and annotate HLZ dimensions. **(T-2).** A computer-generated diagram is desired but not required. At a minimum, display all prominent landmarks and man-made or natural features that may help identify the HLZ (e.g., roads, rivers, buildings). Indicate the recommended approach axis and include an arrow designating true north. Document and describe all hazards both within the boundaries of the HLZ (e.g., rocks, tree stumps, holes, depressions, mounds, fences, poles, trees, wires, ditches) as well as hazards to the approach (e.g., wires, towers, poles, trees). A remark in bold letters must be included if the potential for brown or white out conditions exist. **(T-2).** Unit HLZs used for day-to-day training should include aerial photography and/or imagery. Other HLZ surveys should be supplemented with aerial photography and/or imagery whenever possible.

A6.1.11. **Block 11.** Annotate if photography is available. If available, surveyor, quality control, or safety of flight reviewer will attach photo product(s) with survey submission **(T-3)**. Indicate whether a low level route is associated with the LZ. Individual completing the safety of flight review should know this information and will mark accordingly. **(T-1)**.

**A6.2. Host Nation HLZ Surveys.** For review of a HN HLZ survey in accordance with [paragraph 5.4.2.5](#), validate as much source data as possible for the blocks in the AF Form 4303. At a minimum, safety of flight must review the following items: items 4B, 6, 7 and 8 and attach a copy of the host nation HLZ to the review. **(T-1).** **NOTE:** AF Form 4303 and tactical HLZ surveys and/or assessments conducted in accordance with this manual by validated RAAF CCT HLZ Surveyors certified in accordance with [paragraph 5.4.1.3](#) may be used for USAF and USSF operations.

Figure A6.1. AF FORM 4303, *Helicopter Landing Zone Survey*.

HELICOPTER LANDING ZONE SURVEY		1A. HLZ NAME	1B. ZAR INDEX NO.	2A. COUNTRY	2B. STATE
		3. MAP SERIES/SHEET NUMBER/EDITION/DATE OF MAP			
<b>4. SURVEY APPROVAL/DISAPPROVAL DATA</b>					
A. DATE SURVEYED	TYPED NAME AND GRADE OF SURVEYOR		PHONE NUMBER (DSN)	LOCATION	
B. DATE REVIEWED	TYPED NAME AND GRADE OF REVIEWER		PHONE NUMBER (DSN)	SIGNATURE	
	UNIT AND LOCATION				
C. DATE	TYPED NAME AND GRADE OF APPROVING AUTHORITY		PHONE NUMBER (DSN)	SIGNATURE	
APPROVED <input type="checkbox"/> DISAPPROVED <input type="checkbox"/>	UNIT AND LOCATION				
<b>5. COORDINATING ACTIVITIES</b>					
A. HLZ CONTROLLING AGENCY OR UNIT				PHONE NUMBER (DSN)	
B. RANGE CONTROL				PHONE NUMBER (DSN)	
<b>6. HLZ AXIS DATA (APPROACH/DEPARTURE)</b>					
A. MAGNETIC	B. GRID (MGRS)		C. TRUE	D. SOURCE/DATE OF VARIATION DATA	
<b>7. HLZ COORDINATES</b>					
A. SPHEROID/DATUM	B. GPS DERIVED <input type="checkbox"/> YES <input type="checkbox"/> NO		C. GRID ZONE (52 S PQ)	D. EASTING	E. NORTHING
F. HLZ CENTER - POINT	MGRS COORDINATES	WGS84 LATITUDE (D-M.MM)		WGS84 LONGITUDE (D-M.MM)	
<b>8. HLZ SURFACE DATA</b>					
A. LENGTH (FEET)	B. WIDTH (FEET)	C. ELEVATION		D. QTY/TYPE (2/H-53; 2/H-60)	
E. QUADRANT (OBSTRUCTED/UNOBSTRUCTED)			F. SLOPE		
<b>9. REMARKS</b>					
<p>SURFACE: Example: Grass/BROWNOUT-WHITEOUT: No Factor or CAUTION: BROWNOUT-WHITEOUT CONDITIONS MAY EXIST!            Additional HLZ recommended Approach/Departure Headings: APP xxx.x °/ DEP xxx.x °</p> <ol style="list-style-type: none"> <li>Coordinates and elevation data derived from GPS, maintained horizontal margin of error +/- "xx" meters, (use least accurate when collecting data) Vertical margin of error 1.5 X horizontal error. MAGVAR = "x.x"°E/W/changing "x.x"°E/W per year/derived from "WMM 20xx" as of date surveyed.</li> <li>Administration/Coordination/Planning/Scheduling Instructions:</li> <li>Surveyor Observed Obstacles/Hazards on and within 1,000 meters of the HLZ Boundary (All headings magnetic and distances from HLZ Center point unless otherwise specified). User is responsible for confirming ALL obstacle/hazard locations prior to conducting HLZ operations:</li> </ol> <p><u>Obstacles/Hazards: INSIDE HLZ:</u>            a. e.g., 25' Windsock 15' @ 225° from HLZ Center point.</p> <p><u>Obstacles/Hazards: OUTSIDE HLZ:</u>            a. e.g., 40' Trees border East, South and West borders of HLZ.</p>					

Quadrant Controlling Obstacle: GSR 6:1 or less = Obstructed/GSR 7:1 or more Unobstructed.  
 (Headings 90° or Cardinal/Obstructed or Unobstructed/Obstacle Height/Distance from HLZ Cntr/GSR)  
 xxx°-xxx° or Cardinal/xxx' Obstacle Name/xxxx' from HLZ Center/ GSR xx:1  
 xxx°-xxx° or Cardinal/xxx' Obstacle Name/xxxx' from HLZ Center/ GSR xx:1  
 xxx°-xxx° or Cardinal/xxx' Obstacle Name/xxxx' from HLZ Center/ GSR xx:1  
 xxx°-xxx° or Cardinal/xxx' Obstacle Name/xxxx' from HLZ Center/ GSR xx:1

4. Survey or Observed Terrain Obstacles/Hazards:
  - a. e.g., hilltop est. 2 NM north, elev. unknown.
5. Safety of Flight Review:
  - a. SOF Review Reported Obstacles/Hazards (including terrain) within 5 NM Radius of HLZ Center:
    - i. North: e.g., multiple towers, buildings, high terrain and smokestacks.
    - ii. South: e.g., rapidly rising terrain @ 0.2 NM,
  - b. Additional Information and Airspace:
    - i. xxx are located within a 10 NM Radius of the HLZ Center point.
6. Notes:

HLZ NAME

10. HLZ DIAGRAM

11. PHOTOGRAPHY AVAILABLE  
 YES     NO

LOW LEVEL ROUTES  
 NONE AVAILABLE  
 ROUTE NAME/DESIGNATOR

**Figure A6.2. CV-22 HLZ Size.**

Operational Weight (Empty) - 37,500  
 Max. Gross Weight (VTOL) - 52,600  
 Max. Gross Weight (STOL) - 57,000  
 Emergency War Order GW (VTOL) - 60,500  
 Rotor Size - 85'  
 Length - 58'  
 Footprint Width - 15'  
 Footprint Length - 25'  
 Minimum HLZ Size Training - 170' x 170'  
 Minimum HLZ Dust Out/Low Vis - 240' x 240'  
 Contingency - 135' Width x 110' Length  
**Note:** For multiple CV-22, individual center points "zeroes" should be separated by 500'

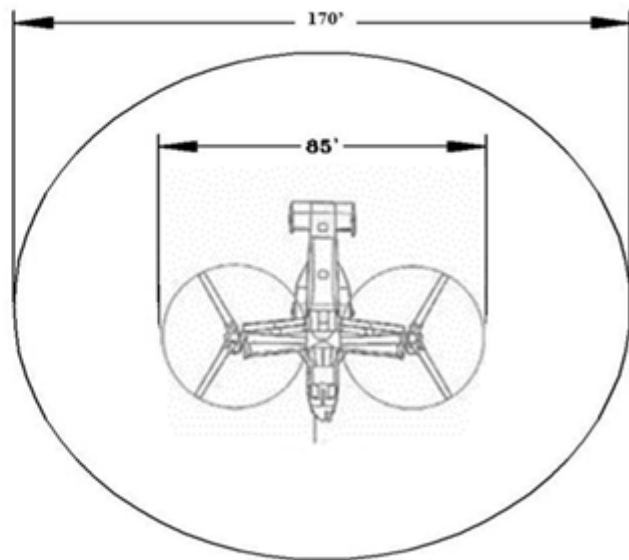
**Figure A6.3. UH-1/TH-1 HLZ Size.**

Operational Weight (Empty) – 8,000  
 Max. Gross Weight (VTOL) – 10,500  
 UH-1N Emergency War Order Weight – 11,000  
 Rotor Size - 48'  
 Length - 58'  
 Footprint Width – 9' 4"  
 Footprint Length - 13'  
 Minimum HLZ Size Training - 100' x 100'  
 Contingency – 25' clearance from any portion of the helicopter to the nearest obstacle.

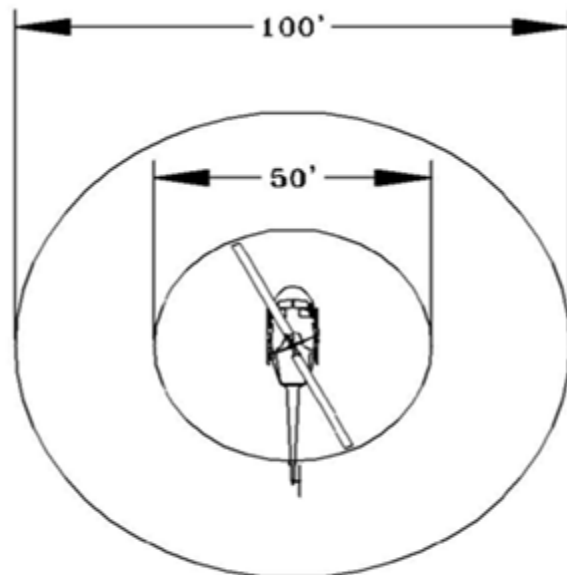

**National Emergency/Nuclear Weapons Security Contingency Weight (UH-1N) – 11,000**  
**UH-1N Length – 57' 3.3"**  
**UH-1N Footprint Width – 9' 1"**

**Figure A6.4. HH-60 HLZ Size.**

Operational Weight (Empty) – 14,600  
 Max. Gross Weight – 22,000  
 Emergency War Order Weigh – 22,500  
 Rotor Size – 54’  
 Length – 65’  
 Footprint Width – 8’  
 Footprint Length – 40’  
 Minimum HLZ Size Training – 120’ x 120’  
 Contingency – 25’ clearance from any portion of the helicopter to the nearest obstacle

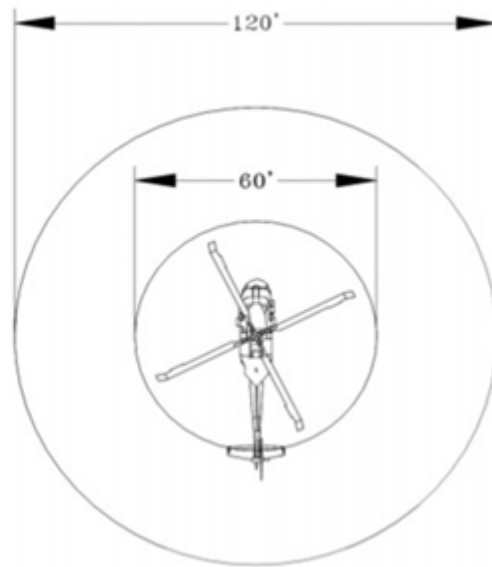

**Figure A6.5. MH-139 HLZ Size.**

Operational Weight (Empty) - 9,700 lbs.  
 Max. Gross Weight – 15,432 lbs.  
 Emergency War Order Weight – N/A  
 Rotor Size – 45.27’  
 Length – 54.55’  
 Footprint Width – 10’  
 Footprint Length – 14.24’  
 Minimum HLZ Size Training - 100’ x 100’  
 Contingency - 25’ clearance from any portion of the helicopter to the nearest obstacle.

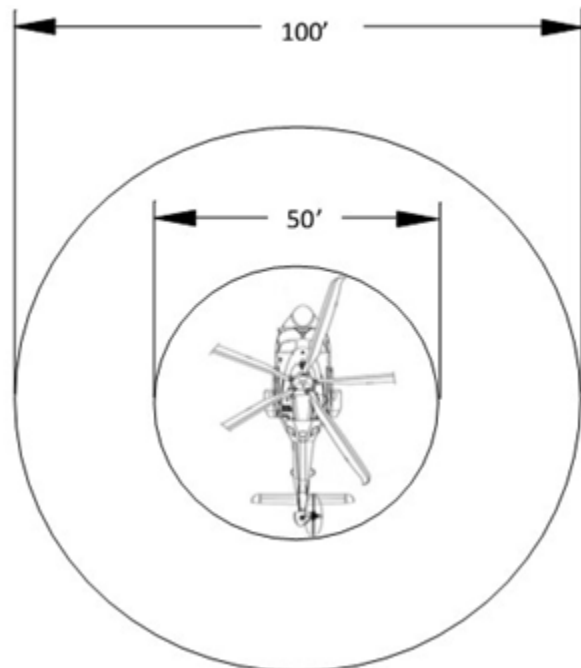



**Figure A6.6. MH-47E HLZ Size.**

Operational Weight (Empty) - 32,000  
 Max. Gross Weight - 50,000  
 Emergency War Order Weight - 54,000  
 Rotor Size - 60'  
 Length - 99'  
 Footprint Width - 9'  
 Footprint Length - 30'  
 Minimum HLZ Size Training - 120' x 120'  
 Contingency - 110'W x 140'L

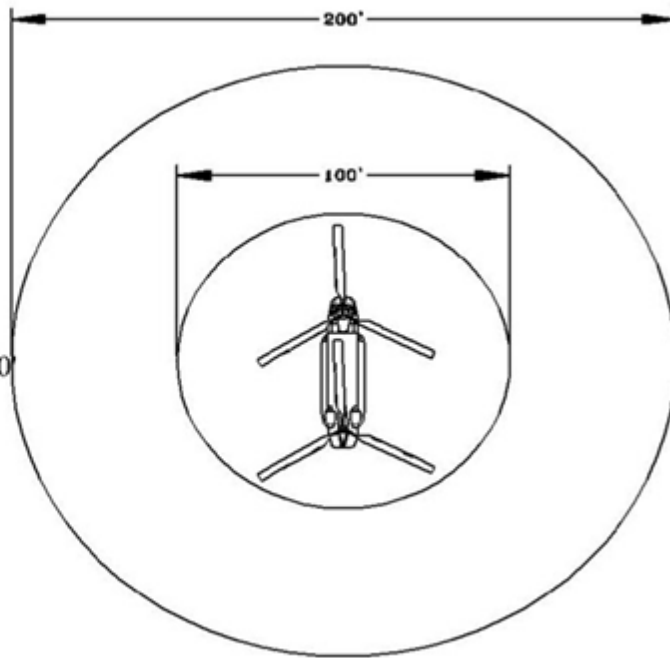
**Figure A6.7. MH-6/AH-6 HLZ Size.**

Operational Weight (Empty) - 2,200  
 Max. Gross Weight - 3,100  
 Emergency War Order Weight - 3,950  
 Rotor Size - 27'  
 Length - 32'  
 Footprint Width - 6'  
 Footprint Length - 7'  
 Minimum HLZ Size Training - 50' x 50'  
 Contingency - 35'W x 40'L

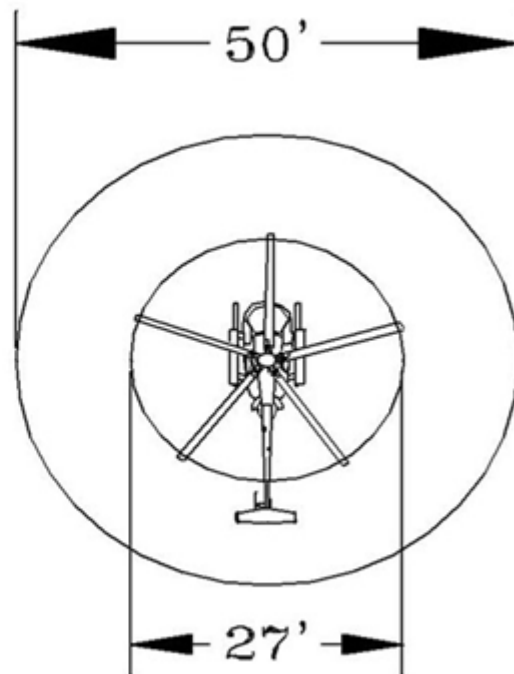

Figure A6.8. HLZ Survey Diagram Dimensional Illustration.

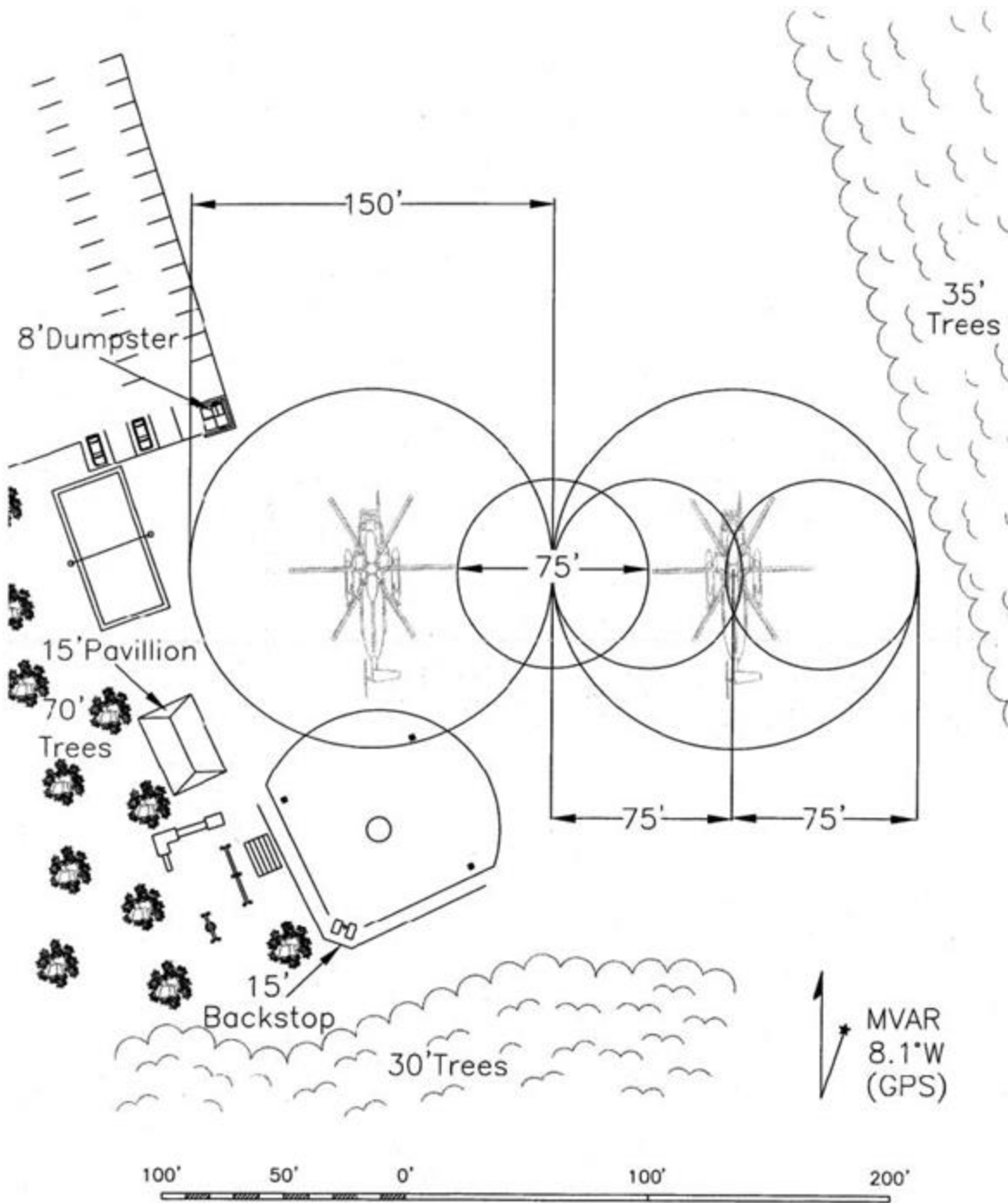
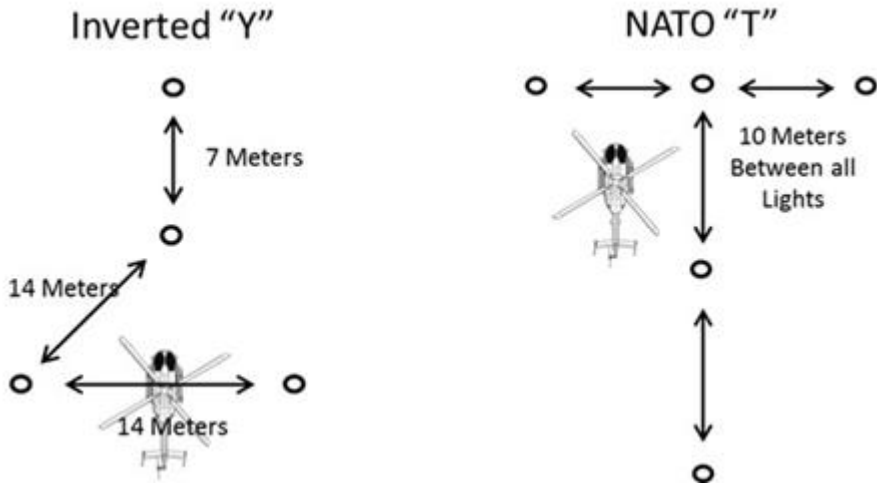

Figure A6.9. Common HLZ Night Markings.



## Attachment 7

## GUIDANCE CONCERNING AF FORM 4304, DZ/LZ CONTROL LOG

**A7.1. AF Form 4304.** In accordance with [paragraph 3.13.5.8](#), it is the responsibility of the DZC to ensure this form is complete and accurate. Group Tactics, or equivalent, will maintain completed AF Form 4304 in accordance with Air Force Information Management Systems. **(T-2)**.

**A7.2.** Use the instructions and sample entries listed below to complete AF Form 4304 in [Figure A7.1](#).

A7.2.1. **DATE.** Enter date and year. When a “time” is required, use local or Greenwich Mean Time consistent with the date.

A7.2.2. **LOCATION.** Enter DZ name.

A7.2.3. **CCT AND UNIT.** DZSTL name and unit.

A7.2.4. **DZ/LZ CONTROL OFFICER AND UNIT.** Self-explanatory.

A7.2.5. **DZSO AND UNIT.** Self-explanatory.

A7.2.6. **LINE NO.** Mission sequence number of each aircraft.

A7.2.7. **TYPE ACFT.** Mission design series.

A7.2.8. **UNIT.** Unit of aircraft.

A7.2.9. **CALL SIGN.** Call sign of lead and, if applicable, formation position number.

A7.2.10. **TYPE MSN.** Refer to “LEGEND” for abbreviations.

A7.2.11. **ETA.** Estimated time of arrival, estimated TOT, or S3 air brief. Keep the unit of time consistent throughout the form (e.g., local or Greenwich Mean Time).

A7.2.12. **ATA/ATD.** Actual time of every pass or actual time of departure.

A7.2.13. **STRIKE REPORT.**

A7.2.13.1. **YDS.** Distance first jumper/container/pallet lands from PI in yards. If within 25 yards it is scored a PI.

A7.2.13.2. **CLOCK.** Use direction of flight as 12 o'clock and back its azimuth as 6 o'clock, estimate direction from PI to first jumper/container/pallet. If time and conditions permit, the actual measurement is preferred.

A7.2.14. **LZ.** Mark the “S” box if a landing occurred between the beginning of the touchdown zone and the first 500 feet. If the landing was not successful (e.g., go-around), short of the touchdown zone, or 500 feet beyond the beginning of the touchdown zone, mark the “U” box and provide comments in the REMARKS box.

A7.2.15. **SURF WIND.** Surface wind direction in degrees, and velocity in knots.

A7.2.16. **SCORE METHOD.** Refer to “LEGEND” for abbreviations.

A7.2.17. **MEAN EFFECTIVE WIND.** Time taken and at what altitude.

A7.2.17.1. **TIME.** Self-explanatory.

A7.2.17.2. **ALT.** Should be drop altitude.

A7.2.17.3. **DIR & LVL.** Wind direction in degrees and velocity in knots.

A7.2.18. **REMARKS.** Enter remarks as appropriate.

**Figure A7.1. AF FORM 4304, Drop Zone/Landing Zone Control Log.**

DROP ZONE/LANDING ZONE CONTROL LOG														DATE			
LOCATION				CCT AND UNIT			DZLZ CONTROL OFFICER AND UNIT				DROP ZONE SAFETY OFFICER AND UNIT						
LEGEND																	
AH-Airland (Heavy) AL-Airland CD-CDS/CRUCRS GM-GMRS				HE - Heavy Equipment HO - HALOHAHO IL - Inverted "L"				LS-Instrument Landing System PE-Personnel RB-Radar Beacon Drop				SCORE METHOD M - Measured P - Paced E - Estimated					
LINE NO	TYPE ACFT	UNIT	CALL SIGN	TYPE MSN	ETA	ATA		STRIKE REPORT		LZ		SURF WIND	SCORE METHOD	MEAN EFFECTIVE WIND			REMARKS
						ATD	YDS	CLOCK	S	U	TIME			ALT	DIR & VEL		
1																	
2																	
3																	
4																	
5																	
6																	
7																	
8																	
9																	
10																	
11																	
12																	
13																	
14																	
15																	

AF IMT 4304, 20020903, V1

REPLACES AMC 168, DEC 92

Attachment 8

ADDITIONAL GUIDANCE CONCERNING TACTICAL LZ SURVEYS.

Table A8.1. Tactical LZ Survey.

<b>Tactical LZ Survey (12-Line)</b>
<p>This brief may be transmitted by voice or data. Units of measure are standard unless briefed and/or denoted. Include imagery as time and/or conditions permit. Lines 2-6, 12, are mandatory read backs (*). The controller may request additional read backs.</p> <p>Controller: “ _____, this is _____ for Tactical LZ Control!” (voice only transmit)                      (aircraft call sign) (controller call sign)</p> <p>1. Call Sign: “ _____ ”</p> <p>*2. Runway capability: Controlling CBR “ _____ ”</p> <p>*3. Hazards “ _____ ”                      (By Exception, see Note)</p> <p>*4. Runway Dimensions (feet): Length: “ _____ ” Width: “ _____ ” Overrun: “ _____ ”</p> <p>*5. Approach End Location: “ _____ ” MSL Elevation: “ _____ MSL ”                      (MGRS, latitude/longitude)</p> <p>*6. Departure End Location: “ _____ ” MSL Elevation: “ _____ MSL ”                      (MGRS, latitude/longitude)</p> <p>7. Glideslope Ratio (From end unless displaced, primary rwy/opposite direction rwy): “ _____ ”</p> <p>8. RWY Longitudinal Slope: “ _____ ” (ID individual controlling slopes that affect aircraft performance in Hazards)</p> <p>9. Surface: “ _____ ”                      (e.g., sand, gravel, silt, clay, asphalt, concrete)</p> <p>10. Runway Condition Rating (RCR): “ _____ ”</p> <p>11. Surface Wind, Temperature: “ _____ ”                      (ex: Wind 240(mag)/8(knots), 60°F)</p> <p>*12. Restrictions: “ _____ ”                      (e.g., runway in use/approach/egress directions. Tactical approaches)</p> <p>REMARKS (as appropriate):                      Airfield markings/Locations and sizes of taxiways, aprons/threats to aircraft/enemy threat suppression coordinated/position of friendlies/hazards to ground movement (e.g., structures, terrain, towers)/airspace de-confliction, SPACI, RFF, center point grid.</p> <p>Additional WX data: Estimated ceiling and visibility</p> <p>Timing                      Time on Target (TOT): “ _____ ” or                      Time to Target (TTT): “ _____ ”</p> <p><b>NOTE:</b> “By Exception” information includes conditions that affect aircraft performance based on 3.3. LZ Minimums (e.g., Distresses, WBC, threshold displacements, vertical obstruction clearance violations, steep transverse slope. Include locations.)</p>
<b>UNCLASSIFIED</b>

## Attachment 9

## ADDITIONAL GUIDANCE CONCERNING LZS

Table A9.1. Accident Potential Zones and Exclusion Areas.

Accident Potential Zones (APZ) and Exclusion Areas for LZs			
Item #	Item Description	Dimensions	Remarks
1	APZ-LZ Length	762 meters (2,500')	<p>Limit or report the following, where possible, within the APZ-LZ (T-2):</p> <ul style="list-style-type: none"> <li>• Actions that release any substances into the air that would impair visibility or otherwise interfere with operating aircraft, such as steam, dust and smoke.</li> <li>• Actions that produce electrical emissions that would interfere with aircraft and/or communications or navigational aid systems.</li> <li>• Actions that produce light emissions, direct or indirect (reflective), that might interfere with pilot vision.</li> <li>• Items that unnecessarily attract birds or waterfowl, such as sanitary landfills, feeding stations, or certain types of crops or vegetation.</li> <li>• Explosive facilities or activities.</li> <li>• Troop concentrations, such as housing areas, dining or medical facilities and recreational fields that include spectators.</li> </ul>
2	APZ-LZ Width	Unoccupied Area: 152.5 meters (500') Occupied and Built-up Area: 305 meters (1,000')	<ul style="list-style-type: none"> <li>• For cases where a training LZ may be sited near permanently occupied facilities or where new facilities may be sited near a LZ, use 305 meters (1,000') wide APZ-LZ.</li> </ul>



3	Exclusion Area	Unoccupied Area: 213.5 meters (700') Occupied and Built-up Area: 305 meters (1,000')	Limit or report the following, where possible, within the exclusion area (T-2): The purpose of the exclusion area is to restrict development of facilities around the LZ. Only features required to operate the LZ or adjacent runways, such as operational surfaces (e.g., taxiways, aprons), navigational aids, airfield lights/signs, aircraft/support equipment and cargo loading and unloading areas/equipment, are permissible in the exclusion area. Personnel formations, encampments, parked vehicles, storage areas, buildings, etc. are excluded from this area. Roads, fences and trees are acceptable. The exclusion area is centered on the runway and extends the length of the runway plus 500' beyond thresholds at each end. For long-term use LZs, restricting use of available land beyond the minimum distances listed here is highly recommended. The goal is to provide the greatest margin of safety for personnel, equipment and facilities. For cases where a training LZ may be sited near permanently occupied facilities or where new facilities may be sited near a LZ, use 305 meters (1,000') wide exclusion area.
---	----------------	---	---

**A9.1. Additional Light Tactical Fixed Wing (LTFW) Minimums.** Survey potential LZs that do not meet minimum C-130 criteria to accommodate the largest possible LTFW category or aircraft. **Table A9.2** lists the minimum LZ dimensions for generic LTFW categories. Survey potential LZs that cannot accommodate the dimensions for a generic LTFW category for a specific aircraft’s criteria (e.g., C-145A), however this may restrict use by other aircraft types. **Paragraph A9.2** provides LTFW runway width and lateral obstruction clearance criteria formulas utilized to identify minimum requirements for specific LTFW airframes.

**Table A9.2. Minimum Dimensions for Generic LTFW Aircraft Categories.**

LTFW Category	Min Rwy Width <sup>1</sup>	Min Rwy Length <sup>2</sup>	Zone A Width	Zone B Width
Small	24'	1,000'	34'	8'
Medium	30'	2,000'	42' 6"	10'
<p><b>Notes:</b></p> <p>1. Surveyors should maximize semi-prepared runway widths to allow LZ controllers/pilots to offset landing points and reduce surface rutting on semi-prepared surfaces. If vertical obstacles exist near the edge of a paved/prepared surface, reduce the published width to place these obstacles outside the A/B zones of the surveyed LZ.</p> <p>2. Runway length should be as long as possible to accommodate multiple aircraft types and potential need for displaced threshold for various glide slope ratio requirements.</p>				

**A9.2. LTFW Runway Width and Lateral Obstruction Clearance Formulas.** Minimum runway width for LTFW is 200% of wheel track. Specific LTFW airframes may require wider runways for routine/normal operations or based on crew qualification. Lateral obstruction clearance criteria formula is based A and B zones. Base the size (width) of these zones on aircraft wing span and wheel track and determined using the formulas provided in AFSOC **Figure A9.1**. Zone A extends outward from the edge of the surveyed runway width. Zone B extends outward from the outside edge of zone A. **Figure A9.2** depicts the zone A/B locations.

**Figure A9.1. Zone A and B Formulas.**

$$\text{Zone A} = \frac{\text{Wing Span (WS)} - \text{Wheel Track (WT)}}{2}$$

$$\text{Zone B} = 10\% \text{ of Wing Span (i.e. } 0.1 * \text{WS)}$$

**Figure A9.2. Zone A and Zone B Locations.**



A9.2.1. It is acceptable to conduct operations on a LZ whose survey lists a zone B width that is less than the aircraft's stated requirement, provided the zone A width listed on the survey exceeds the aircraft's minimum requirement by an equal or greater distance. For example, a C-145A may operate on a LZ with a 31' zone A and a 7' zone B. In this case the zone B is 3" less than required but the zone A is 5" greater than required.

A9.2.1.1. Expand insufficient Zone A and/or Zone B survey distances by reducing runway width by an equal amount, down to the minimum runway width requirement. For example, a C-146A aircrew desires to land at a LZ with a runway that is 40' wide, with zone As of 28' and zone Bs of 7'. The LZ zone A is 11" less than the C-146A requirement of 28' and 11". The crew may land at the LZ by treating only 38' of runway width as useable and adding 1' to both zones. The portion of the runway outside this adjusted width will be treated as unusable. **(T-2)**.

A9.2.2. Surveyors and LZSO shall report detailed information on any/all vertical obstructions located within zones A and B (e.g., number and type of obstructions, distance from edge of surveyed LZ or runway centerline, height above cross-sectional runway edge elevation, etc.). **(T-2)**.

A9.2.2.1. Maximum obstacle height for LTFW aircraft. For semi-prepared surface taxiways and runways, obstacles will not be higher than values listed below unless the aircraft flight manual, pilot operating handbook, or aircraft addendum to this manual is more restrictive. **(T-2)**.

- A9.2.2.2. Single-Engine Low-Wing Aircraft: zone A – 12", zone B – 60".
- A9.2.2.3. Single-Engine High-Wing Aircraft: zone A – 12", zone B – 60".
- A9.2.2.4. Multiengine Low-Wing Aircraft: zone A – 4", zone B – 60".
- A9.2.2.5. Multiengine High-Wing Aircraft: zone A – 36", zone B – 60".

**Table A9.3. C-146 Semi-prepared Soil Surface Strength Chart.**

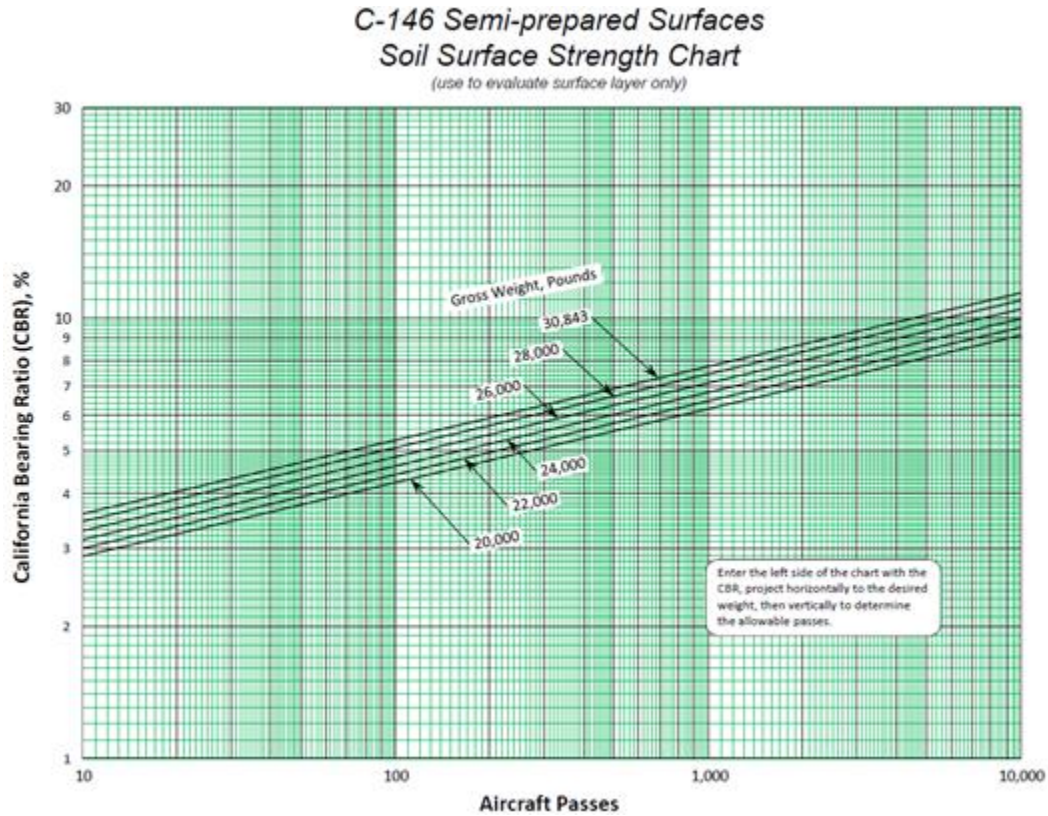

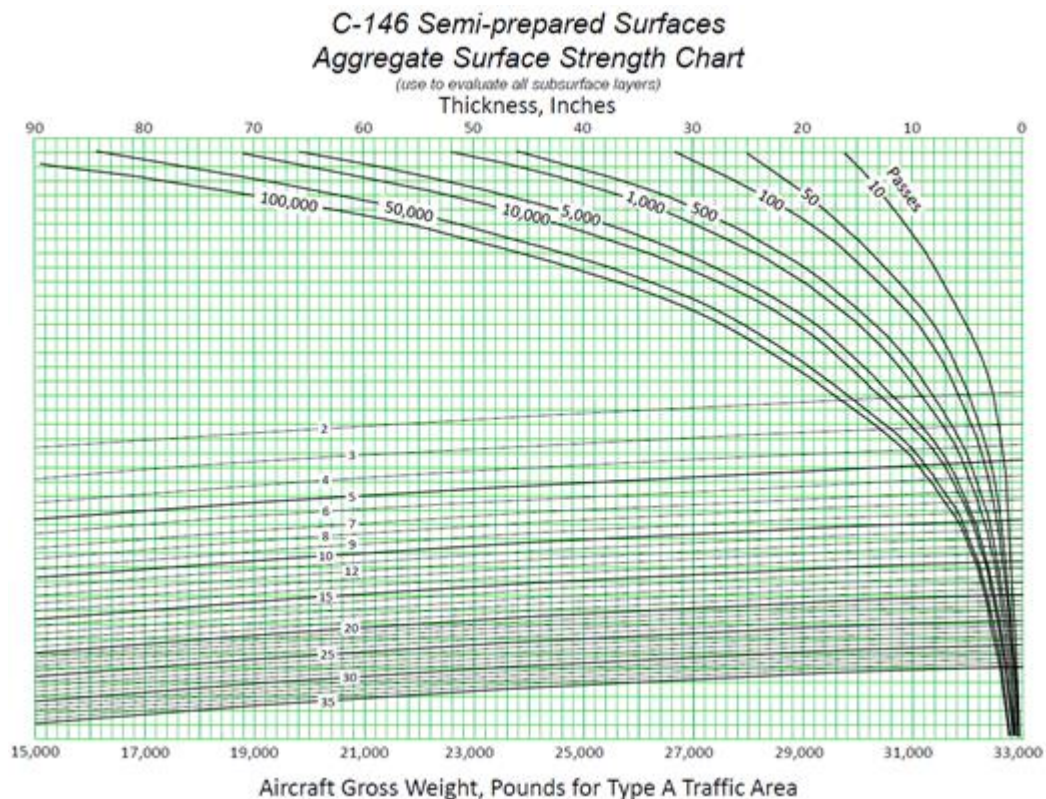
**Table A9.4. C-146 Semi-prepared Aggregate Surface Strength Chart.**

**A9.3. Semi-Prepared Operations Planning.** Recurring use of a LZ with reduced strength risks increased potential for LZ surface distress. Operation planners may base planned operations around LZ survey strength to theorize a number of operational cycles before potential surface distress levels could negatively impact operations; Use the planned number of aircraft and configuration(s) and reported semi-prepared survey strength to identify predicted number of cycles. A single aircraft cycle consists of a single aircraft landing, all taxi and single takeoff. Aircraft cycles are not required to be reported nor tracked, and the distress level is theorized. Therefore, operations planning does not replace the requirement for assessment conducted in accordance with [paragraph 4.3.3](#), it is not required in the LZ survey process, and it is not required for survey approval. Use surveyed controlling CBR profile and/or WBC/allowable passes to directly correlate cycles. Use [Figure A9.3](#) for assistance to conduct evaluations.



Table A9.5. C-17 Semi-Prepared Operations Planning Chart.

INCHES (IN)			Unpaved or Semi-Prepared Strength Requirements for Planning and Operational Determinations (Built using PCASE 2.09.05) C-17 (main 141,6 psi/nose 155 psi) @ 486,000 lbs									
Real World Conditions Use MOST of the time to plan or determine use	Optimum Conditions Very rarely used to plan or determine use	Perfect Conditions Should not be used to plan or determine use	SURFACE CBR REQUIRED	THICKNESS REQUIRED OVER CBR 2	THICKNESS REQUIRED OVER CBR 3	THICKNESS REQUIRED OVER CBR 4	THICKNESS REQUIRED OVER CBR 5	THICKNESS REQUIRED OVER CBR 6	THICKNESS REQUIRED OVER CBR 7	THICKNESS REQUIRED OVER CBR 8	THICKNESS REQUIRED OVER CBR 9	THICKNESS REQUIRED OVER CBR 10
Cycles NO Maintenance	Cycles with Maintenance	PASSES (Engineering / PCASE)		NO GO	NO GO	NO GO	NO GO	NO GO	NO GO	NO GO	NO GO	NO GO
0	0	10	NO GO	NO GO	NO GO	NO GO	NO GO	NO GO	NO GO	NO GO	NO GO	NO GO
0	1	60	14. CBR	19.5 IN	15. IN	13. IN	11. IN	10. IN	9. IN	8.5 IN	8. IN	7.5 IN
0	2	75	15. CBR	20.5 IN	16. IN	13.5 IN	11.5 IN	10.5 IN	9.5 IN	9. IN	8. IN	8. IN
1	5	100	16. CBR	22. IN	17. IN	14. IN	12.5 IN	11. IN	10. IN	9.5 IN	9. IN	8. IN
5	15	200	17 CBR	25.5 IN	19.5 IN	16. IN	14. IN	12.5 IN	11.5 IN	10.5 IN	10. IN	9. IN
8	25	300	19 CBR	27.5 IN	21. IN	17.5 IN	15. IN	13.5 IN	12. IN	11. IN	10.5 IN	10. IN
11	35	400	19 CBR	29. IN	22. IN	18.5 IN	16. IN	14. IN	13. IN	12. IN	11. IN	10. IN
15	45	500	20 CBR	30. IN	23. IN	19. IN	16.5 IN	14.5 IN	13.5 IN	12. IN	11.5 IN	10.5 IN
23	70	750	22 CBR	32.5 IN	24.5 IN	20.5 IN	17.5 IN	15.5 IN	14. IN	13. IN	12. IN	11. IN
31	95	1000	23 CBR	34. IN	26. IN	21.5 IN	18.5 IN	16.5 IN	14.5 IN	13.5 IN	12.5 IN	11.5 IN
48	145	1500	24 CBR	36.5 IN	27.5 IN	22.5 IN	20. IN	17.5 IN	15.5 IN	14.5 IN	13. IN	12.5 IN
65	195	2000	25 CBR	38. IN	29. IN	23.5 IN	20.5 IN	18. IN	16.5 IN	15. IN	14. IN	13. IN
98	295	3000	27 CBR	41. IN	30.5 IN	25. IN	21.5 IN	19. IN	17. IN	16. IN	14.5 IN	13.5 IN
131	395	4000	28 CBR	42.5 IN	32. IN	26. IN	22.5 IN	20. IN	18. IN	16.5 IN	15. IN	14. IN
165	495	5000	29 CBR	43.5 IN	33. IN	27. IN	23. IN	20.5 IN	18.5 IN	17. IN	15.5 IN	14.5 IN
1665	4995	50000	43 CBR	59. IN	44. IN	36. IN	31. IN	27. IN	24. IN	22. IN	20. IN	19. IN
3331	9995	100000	48 CBR	63.5 IN	47.5 IN	39. IN	33. IN	29. IN	26. IN	24. IN	21.5 IN	20. IN

Real World Conditions Use MOST of the time to plan or determine use	Optimum Conditions Very rarely used to plan or determine use	Perfect Conditions Should not be used to plan or determine use	SURFACE CBR REQUIRED	THICKNESS REQUIRED OVER CBR 11	THICKNESS REQUIRED OVER CBR 12	THICKNESS REQUIRED OVER CBR 13	THICKNESS REQUIRED OVER CBR 14	THICKNESS REQUIRED OVER CBR 15	THICKNESS REQUIRED OVER CBR 20	THICKNESS REQUIRED OVER CBR 25	THICKNESS REQUIRED OVER CBR 30	THICKNESS REQUIRED OVER CBR 35
Cycles NO Maintenance	Cycles with Maintenance	PASSES (Engineering / PCASE)		NO GO	NO GO	NO GO	NO GO	NO GO	NO GO	NO GO	NO GO	NO GO
0	0	10	NO GO	NO GO	NO GO	NO GO	NO GO	NO GO	NO GO	NO GO	NO GO	NO GO
0	1	60	14. CBR	7. IN	6.5 IN	6.5 IN	4. IN	-	-	-	-	-
0	2	75	15. CBR	7.5 IN	7. IN	6.5 IN	6.5 IN	4. IN	-	-	-	-
1	5	100	16. CBR	8. IN	7.5 IN	7. IN	7. IN	6.5 IN	4. IN	-	-	-
5	15	200	17. CBR	9. IN	8. IN	8. IN	7.5 IN	7. IN	4. IN	-	-	-
8	25	300	19. CBR	9. IN	9. IN	8.5 IN	8. IN	7.5 IN	4. IN	-	-	-
11	35	400	19. CBR	10. IN	9. IN	8.5 IN	8.5 IN	8. IN	4. IN	-	-	-
15	45	500	20. CBR	10. IN	9.5 IN	9. IN	8.5 IN	8. IN	4. IN	-	-	-
23	70	750	22. CBR	10.5 IN	10. IN	9.5 IN	9. IN	9. IN	7. IN	4. IN	-	-
31	95	1000	23. CBR	11. IN	10.5 IN	10. IN	9.5 IN	9. IN	7.5 IN	4. IN	-	-
48	145	1500	24. CBR	11.5 IN	11. IN	10.5 IN	10. IN	9.5 IN	8. IN	4. IN	-	-
65	195	2000	25. CBR	12. IN	11.5 IN	11. IN	10.5 IN	10. IN	8. IN	4. IN	-	-
98	295	3000	27. CBR	13. IN	12. IN	11.5 IN	11. IN	10.5 IN	8.5 IN	4. IN	-	-
131	395	4000	28. CBR	13. IN	12.5 IN	12. IN	11.5 IN	11. IN	9. IN	4. IN	-	-
165	495	5000	29 CBR	13.5 IN	13. IN	12. IN	11.5 IN	11. IN	9. IN	4. IN	-	-
1665	4995	50000	43 CBR	17.5 IN	16.5 IN	15.5 IN	15. IN	14. IN	11.5 IN	9.5 IN	8. IN	7. IN
3331	9995	100000	48 CBR	63.5 IN	19. IN	18. IN	16.5 IN	16. IN	12.5 IN	10.5 IN	9. IN	7.5 IN

Table A9.6. Continued. C-17 \ Semi-Prepared Operations Planning Chart.

Real World Conditions Use MOST of the time to plan or determine use	Optimum Conditions Very rarely used to plan or determine use	Perfect Conditions Should not be used to plan or determine use	SURFACE CBR REQUIRED	THICKNESS REQUIRED OVER CBR 40	THICKNESS REQUIRED OVER CBR 45	THICKNESS REQUIRED OVER CBR 50
Cycles NO Maintenance	Cycles with Maintenance	PASSES (Engineering / PCASE)				
0	0	10	NO GO	NO GO	NO GO	NO GO
0	1	60	14. CBR	-	-	-
0	2	75	15. CBR	-	-	-
1	5	100	16. CBR	-	-	-
5	15	200	17. CBR	-	-	-
8	25	300	19. CBR	-	-	-
11	35	400	19. CBR	-	-	-
15	45	500	20. CBR	-	-	-
23	70	750	22. CBR	-	-	-
31	95	1000	23. CBR	-	-	-
48	145	1500	24. CBR	-	-	-
65	195	2000	25. CBR	-	-	-
98	295	3000	27. CBR	-	-	-
131	395	4000	28. CBR	-	-	-
165	495	5000	29 CBR	-	-	-
1665	4995	50000	43 CBR	6. IN	4. IN	-
3331	9995	100000	48 CBR	6.5 IN	4. IN	-

NOTE: 1x Cycle represents = single aircraft landing+All Taxi(Back taxi and Apron taxi included)+takeoff \*CBRs are rounded up to nearest whole CBR / \*\*Thickness is rounded up to nearest 1/2 inch

Type Aircraft	Single Use Min Pass Level	Demonstrated Min Pass Level	Cycle/Pass after Min		No Maintenance Factor Adjustment to PW PASSES
C-17	60	-	10	Contingency	3
C-130	10	-	10	Sustainment	2
* LTFW	20	200	10	Permanent	1

Figure A9.3. Example 1 using C-17 Operations Planning Chart.

Question 1: Need to determine if Landing Zone (LZ) will support operation planned/scheduled to be conducted on runway  
 Question 2: What CBR and Thickness minimum requirements are needed for a LZ to be surveyed to in order to support operation.

- Conditions:
- Operation requires 5x C-17 to land taxi and depart.
  - No Maintenance is available on LZ for runway.

NOTE: 1x Cycle represents = single aircraft landing+All Taxi (Back taxi and Apron taxi included)+takeoff

Using note above 5 cycles are needed under the 'Real World Conditions' / Cycles NO Maintenance

- Step 1:** Enter chart under 'Real World Conditions' because NO maintenance is available or is unknown
- Step 2:** Follow chart until you intersect '5' cycles (no maintenance). Then go right record number of engineering passes needed and Surface CBR Required  
 \*200 Engineering Passes is need is needed to get 5 cycles without maintenance  
 \*17 CBR is REQUIRED on the surface

**Answer Q1:** If Surveyed Semi-Prepared Landing Zone reports a PASS LEVEL over 200 Passes you can conduct the 5x required C-17 landings, taxi, departures and can be accomplished max semi-prepare C-130J weight of 175K

- For example we will say that we have estimate a 10 CBR Subbase or subgrade
- Step 3:** Find your required Surface CBR Required 17 CBR go to 'Thickness Required Over CBR' for 10 CBR and find where the depth they intersect at  
 \* 9 inches of a Surface CBR of 17 above a Subbase/Subgrade CBR of 10

**Answer Q2:** Surface: 9" CBR 17 (Controlling Layer) / Subbase or Subgrade of 10  
 C-17 WBC = 486K / 200 Passes

Note: It is impossible to get 200 passes with any CBR smaller than 17 for the C-17, but what does change is the thickness of the surface layer depending on the strength of the layer beneath it.

- Empirical Standards
- The thickness requirement will increase the smaller the CBR is in relation to the Surface CBR required
  - The thickness requirement will decrease the larger the CBR is in relation to Surface CBR Required
  - Minimum Thickness Required is 4 Inches and once the CBR of the Subbase/Subgrade is equal to or greater than the surface CBR, Surface thickness requirement is always 4 inches

INCHES (IN)			Unpaved or Semi-Prepared Strength Requirements for Planning and Operational Determinations (Built using PCASE 2.09.05) C-17 (main 141,6 psi/nose 155 psi) @ 486,000 lbs									
Real World Conditions Use MOST of the time to plan or determine use	Optimum Conditions Very rarely used to plan or determine use	Perfect Conditions Should not be used to plan or determine use	SURFACE CBR REQUIRED	THICKNESS REQUIRED OVER CBR 2	THICKNESS REQUIRED OVER CBR 3	THICKNESS REQUIRED OVER CBR 4	THICKNESS REQUIRED OVER CBR 5	THICKNESS REQUIRED OVER CBR 6	THICKNESS REQUIRED OVER CBR 7	THICKNESS REQUIRED OVER CBR 8	THICKNESS REQUIRED OVER CBR 9	THICKNESS REQUIRED OVER CBR 10
Cycles NO Maintenance	Cycles with Maintenance	PASSES (Engineering / PCASE)										
	0	10	NO GO	NO GO	NO GO	NO GO	NO GO	NO GO	NO GO	NO GO	NO GO	NO GO
	1	60	14 BR	19.5 IN	15. IN	13. IN	11. IN	10. IN	9. IN	8.5 IN	8. IN	7.5 IN
	2	75	15 BR	20.5 IN	16. IN	13.5 IN	11.5 IN	10.5 IN	9.5 IN	9. IN	8. IN	8. IN
	5	100	16 BR	22. IN	17. IN	14. IN	12.5 IN	11. IN	10. IN	9.5 IN	9. IN	8. IN
	5	200	17 CBR	23.5 IN	19.5 IN	16. IN	14. IN	12.5 IN	11. IN	10. IN	9. IN	9. IN
	8	300	19 CBR	27.5 IN	21. IN	17.5 IN	15. IN	13.5 IN	12. IN	11. IN	10.5 IN	10. IN



Table A9.7. C-130J Semi-Prepared Operations Planning Chart.

INCHES (IN)			Unpaved or Semi-Prepared Strength Requirements for Planning and Operational Determinations (Built using PCASE 2.09.05) C-130J (main 118 psi/nose 60 psi) @ 175,000 lbs										
Real World Conditions Use MOST of the time to plan or	Optimum Conditions Very rarely used to plan or determine use	Perfect Conditions Should not be used to plan or determine use	SURFACE CBR REQUIRED	THICKNESS REQUIRED OVER CBR 2	THICKNESS REQUIRED OVER CBR 3	THICKNESS REQUIRED OVER CBR 4	THICKNESS REQUIRED OVER CBR 5	THICKNESS REQUIRED OVER CBR 6	THICKNESS REQUIRED OVER CBR 7	THICKNESS REQUIRED OVER CBR 8	THICKNESS REQUIRED OVER CBR 9	THICKNESS REQUIRED OVER CBR 10	
Cycles NO Maintenance	Cycles with Maintenance	PASSES (Engineering / PCASE)											
0	0	1	NO GO	NO GO	NO GO	NO GO	NO GO	NO GO	NO GO	NO GO	NO GO	NO GO	
0	1	10	8. CBR	9. IN	7.5 IN	6.5 IN	5.5 IN	5. IN	4.5 IN	4. IN	-	-	
1	5	50	11. CBR	14. IN	11.5 IN	9.5 IN	8.5 IN	8. IN	7. IN	6.5 IN	6. IN	6. IN	
3	10	100	12. CBR	16. IN	13. IN	11. IN	10. IN	9. IN	8. IN	7.5 IN	7. IN	6.5 IN	
6	20	200	14. CBR	18.5 IN	14.5 IN	12.5 IN	11. IN	10. IN	9. IN	8.5 IN	8. IN	7.5 IN	
10	30	300	14. CBR	20. IN	16. IN	13.5 IN	12. IN	11. IN	10. IN	9. IN	8.5 IN	8. IN	
13	40	400	15. CBR	21. IN	16.5 IN	14. IN	12.5 IN	11. IN	10. IN	9.5 IN	9. IN	8.5 IN	
16	50	500	16. CBR	21.5 IN	17. IN	14.5 IN	13. IN	11.5 IN	10.5 IN	10. IN	9. IN	8.5 IN	
25	75	750	17. CBR	23. IN	18. IN	15.5 IN	13.5 IN	12. IN	11. IN	10.5 IN	10. IN	9. IN	
33	100	1000	18. CBR	23.5 IN	19. IN	16. IN	14. IN	13. IN	11.5 IN	10.5 IN	10. IN	9.5 IN	
50	150	1500	19. CBR	25. IN	20. IN	17. IN	15. IN	13.5 IN	12. IN	11.5 IN	10.5 IN	10. IN	
66	200	2000	20. CBR	26. IN	21. IN	18. IN	15.5 IN	14. IN	13. IN	12. IN	11. IN	10.5 IN	
100	300	3000	21. CBR	28. IN	22. IN	18.5 IN	16. IN	14.5 IN	13.5 IN	12.5 IN	11.5 IN	11. IN	
133	400	4000	22. CBR	29. IN	22.5 IN	19. IN	17. IN	15. IN	14. IN	13. IN	12. IN	11. IN	
166	500	5000	23. CBR	29.5 IN	23. IN	20. IN	17. IN	15.5 IN	14. IN	13. IN	12. IN	11.5 IN	
1666	5000	50000	33. CBR	38. IN	30. IN	25. IN	22. IN	19.5 IN	18. IN	16.5 IN	15.5 IN	14.5 IN	
3333	10000	100000	37. CBR	41. IN	31.5 IN	26.5 IN	23.5 IN	21. IN	19. IN	17.5 IN	16.5 IN	15.5 IN	
Real World Conditions Use MOST of the time to plan or determine use	Optimum Conditions Very rarely used to plan or determine use	Perfect Conditions Should not be used to plan or determine use	SURFACE CBR REQUIRED	THICKNESS REQUIRED OVER CBR 11	THICKNESS REQUIRED OVER CBR 12	THICKNESS REQUIRED OVER CBR 13	THICKNESS REQUIRED OVER CBR 14	THICKNESS REQUIRED OVER CBR 15	THICKNESS REQUIRED OVER CBR 16	THICKNESS REQUIRED OVER CBR 17	THICKNESS REQUIRED OVER CBR 18	THICKNESS REQUIRED OVER CBR 19	
Cycles NO Maintenance	Cycles with Maintenance	PASSES (Engineering / PCASE)											
0	0	1	NO GO	NO GO	NO GO	NO GO	NO GO	NO GO	NO GO	NO GO	NO GO	NO GO	
0	1	10	8. CBR	-	-	-	-	-	-	-	-	-	
1	5	50	11. CBR	4. IN	-	-	-	-	-	-	-	-	
3	10	100	12. CBR	6. IN	4. IN	-	-	-	-	-	-	-	
6	20	200	14. CBR	7. IN	6.5 IN	6.5 IN	4. IN	-	-	-	-	-	
10	30	300	14. CBR	7.5 IN	7. IN	7. IN	4. IN	-	-	-	-	-	
13	40	400	15. CBR	8. IN	7.5 IN	7. IN	6.5 IN	4. IN	-	-	-	-	
16	50	500	16. CBR	8. IN	7.5 IN	7. IN	7. IN	6.5 IN	4. IN	-	-	-	
25	75	750	17. CBR	8.5 IN	8. IN	7.5 IN	7.5 IN	7. IN	6.5 IN	4. IN	-	-	
33	100	1000	18. CBR	9. IN	8.5 IN	8. IN	7.5 IN	7. IN	7. IN	6.5 IN	4. IN	-	
50	150	1500	19. CBR	9.5 IN	9. IN	8.5 IN	8. IN	7.5 IN	7. IN	7. IN	6.5 IN	4. IN	
66	200	2000	20. CBR	10. IN	9. IN	9. IN	8. IN	8. IN	7.5 IN	7. IN	7. IN	6.5 IN	
100	300	3000	21. CBR	10. IN	9.5 IN	9. IN	8.5 IN	8. IN	8. IN	7.5 IN	7. IN	7. IN	
133	400	4000	22. CBR	10.5 IN	10. IN	9.5 IN	9. IN	8.5 IN	8. IN	8. IN	7.5 IN	7. IN	
166	500	5000	23. CBR	11. IN	10. IN	9.5 IN	9. IN	9. IN	8.5 IN	8. IN	7.5 IN	7. IN	
1666	5000	50000	33. CBR	13.5 IN	13. IN	12. IN	11.5 IN	11. IN	10.5 IN	10. IN	9.5 IN	9. IN	
3333	10000	100000	37. CBR	14.5 IN	13.5 IN	13. IN	12. IN	11.5 IN	11. IN	10.5 IN	10. IN	9.5 IN	

Table A9.8. Continued. C-130J Semi-Prepared Operations Planning Chart.

Real World Conditions Use MOST of the time to plan or	Optimum Conditions Very rarely used to plan or determine use	Perfect Conditions Should not be used to plan or determine use	SURFACE CBR REQUIRED	THICKNESS REQUIRED OVER CBR 20	THICKNESS REQUIRED OVER CBR 21	THICKNESS REQUIRED OVER CBR 22	THICKNESS REQUIRED OVER CBR 23	THICKNESS REQUIRED OVER CBR 24	THICKNESS REQUIRED OVER CBR 25	THICKNESS REQUIRED OVER CBR 30	THICKNESS REQUIRED OVER CBR 33	THICKNESS REQUIRED OVER CBR 37
Cycles NO Maintenance	Cycles with Maintenance	PASSES (Engineering / PCASE)										
0	0	1	NO GO	NO GO	NO GO	NO GO	NO GO	NO GO	NO GO	NO GO	NO GO	NO GO
0	1	10	8. CBR	-	-	-	-	-	-	-	-	-
1	5	50	11. CBR	-	-	-	-	-	-	-	-	-
3	10	100	12. CBR	-	-	-	-	-	-	-	-	-
6	20	200	14. CBR	-	-	-	-	-	-	-	-	-
10	30	300	14. CBR	-	-	-	-	-	-	-	-	-
13	40	400	15. CBR	-	-	-	-	-	-	-	-	-
16	50	500	16. CBR	-	-	-	-	-	-	-	-	-
25	75	750	17. CBR	-	-	-	-	-	-	-	-	-
33	100	1000	18. CBR	-	-	-	-	-	-	-	-	-
50	150	1500	19. CBR	-	-	-	-	-	-	-	-	-
66	200	2000	20. CBR	4. IN	-	-	-	-	-	-	-	-
100	300	3000	21. CBR	6.5 IN	4. IN	-	-	-	-	-	-	-
133	400	4000	22. CBR	7. IN	6.5 IN	4. IN	-	-	-	-	-	-
166	500	5000	23 CBR	7. IN	7. IN	6.5 IN	4. IN	-	-	-	-	-
1666	5000	50000	33 CBR	9. IN	8.5 IN	8. IN	8. IN	7.5 IN	7. IN	6. IN	4. IN	-
3333	10000	100000	37 CBR	9. IN	9. IN	8.5 IN	8. IN	8. IN	7.5 IN	6.5 IN	6. IN	4. IN

NOTE: 1x Cycle represents = single aircraft landing+All Taxi(Back taxi and Apron taxi included)+takeoff \*CBRs are rounded up to nearest whole CBR / \*\*Thickness is rounded up to nearest 1/2 inch

Type Aircraft	Single Use Min Pass Level	Demonstrated Min Pass Level	Cycle/Pass after Min	No Maintenance Factor Adjustment to PW PASSES	
C-17	60	-	10	Contingency	3
C-130	10	-	10	Sustainment	2
* LTFW	20	200	10	Permanent	1



Table A9.9. C-146 Semi-Prepared Operations Planning Chart.

INCHES (IN)			Unpaved or Semi-Prepared Strength Requirements for Planning and Operational Determinations (Built using PCASE 2.09.05) C-146 (main 101 psi/nose 67 psi) @ 30,843 lbs									
Real World Conditions Use MOST of the time to plan or determine use	Optimum Conditions Very rarely used to plan or determine use	Perfect Conditions Should not be used to plan or determine use	SURFACE CBR REQUIRED	THICKNESS REQUIRED OVER CBR 2	THICKNESS REQUIRED OVER CBR 3	THICKNESS REQUIRED OVER CBR 4	THICKNESS REQUIRED OVER CBR 5	THICKNESS REQUIRED OVER CBR 6	THICKNESS REQUIRED OVER CBR 7	THICKNESS REQUIRED OVER CBR 8	THICKNESS REQUIRED OVER CBR 9	THICKNESS REQUIRED OVER CBR 10
Cycles NO Maintenance	Cycles with Maintenance	PASSES (Engineering / PCASE)		NO GO	NO GO	NO GO	NO GO	NO GO	NO GO	NO GO	NO GO	NO GO
0	0	10	NO GO	NO GO	NO GO	NO GO	NO GO	NO GO	NO GO	NO GO	NO GO	NO GO
0	1	20	5. CBR	4. IN	-	-	-	-	-	-	-	-
1	4	50	5. CBR	4. IN	-	-	-	-	-	-	-	-
2	6	75	5. CBR	5.5 IN	4.5 IN	4 IN	-	-	-	-	-	-
3	9	100	6. CBR	6. IN	5 IN	4 IN	-	-	-	-	-	-
4	14	150	6. CBR	6.5 IN	5 IN	4 IN	-	-	-	-	-	-
6	19	200	6. CBR	7. IN	5.5 IN	5. IN	4. IN	-	-	-	-	-
9	29	300	7. CBR	7.5 IN	6. IN	5. IN	4.5 IN	4. IN	-	-	-	-
13	39	400	7. CBR	8. IN	6.5 IN	5.5 IN	5. IN	4. IN	-	-	-	-
16	49	500	7 CBR	8.5 IN	6.5 IN	5.5 IN	5. IN	4.5 IN	4. IN	-	-	-
24	74	750	8 CBR	9. IN	7. IN	6. IN	5. IN	4.5 IN	4.65 IN	4. IN	-	-
33	99	1000	8 CBR	9.5 IN	7.5 IN	6. IN	5.65 IN	5. IN	4.5 IN	4. IN	-	-
49	149	1500	9 CBR	10. IN	8. IN	6.5 IN	6. IN	5. IN	5. IN	4.5 IN	4. IN	-
66	199	2000	9 CBR	10.5 IN	8. IN	6.5 IN	6. IN	5.5 IN	5. IN	4.5 IN	4. IN	-
99	299	3000	10 CBR	11. IN	9. IN	7.5 IN	6.5 IN	6. IN	5. IN	5. IN	4.5 IN	4. IN
133	399	4000	10 CBR	11.5 IN	9. IN	7.5 IN	6.5 IN	6. IN	5.5 IN	5. IN	4.5 IN	4. IN
166	499	5000	11 CBR	12. IN	9.5 IN	8. IN	7. IN	6. IN	5.5 IN	5. IN	4.5 IN	4.5 IN
333	999	10000	12 CBR	13. IN	10. IN	8.5 IN	7.5 IN	6.5 IN	6. IN	5.5 IN	5. IN	5. IN
499	1499	15000	13 CBR	14. IN	10.5 IN	9. IN	8. IN	7. IN	6.5 IN	6. IN	5.5 IN	5. IN
833	2499	25000	15 CBR	14.5 IN	11.5 IN	9.5 IN	8.5 IN	7.5 IN	7. IN	6. IN	6. IN	5.5 IN
1666	4999	50000	16 CBR	16. IN	12.5 IN	10.5 IN	9. IN	8. IN	7. IN	6.5 IN	6. IN	6. IN
3333	9999	100000+	17 CBR	17. IN	13.5 IN	11. IN	10.5 IN	8.5 IN	7.5 IN	7. IN	6.5 IN	6. IN

Real World Conditions Use MOST of the time to plan or determine use	Optimum Conditions Very rarely used to plan or determine use	Perfect Conditions Should not be used to plan or determine use	SURFACE CBR REQUIRED	THICKNESS REQUIRED OVER CBR 11	THICKNESS REQUIRED OVER CBR 12	THICKNESS REQUIRED OVER CBR 13	THICKNESS REQUIRED OVER CBR 14	THICKNESS REQUIRED OVER CBR 15	THICKNESS REQUIRED OVER CBR 16	THICKNESS REQUIRED OVER CBR 17
Cycles NO Maintenance	Cycles with Maintenance	PASSES (Engineering / PCASE)		NO GO	NO GO	NO GO	NO GO	NO GO	NO GO	NO GO
0	0	10	NO GO	NO GO	NO GO	NO GO	NO GO	NO GO	NO GO	NO GO
0	1	20	5. CBR	-	-	-	-	-	-	-
1	4	50	5. CBR	-	-	-	-	-	-	-
2	6	75	5. CBR	-	-	-	-	-	-	-
3	9	100	6. CBR	-	-	-	-	-	-	-
4	14	150	6. CBR	-	-	-	-	-	-	-
6	19	200	6. CBR	-	-	-	-	-	-	-
9	29	300	7. CBR	-	-	-	-	-	-	-
13	39	400	7. CBR	-	-	-	-	-	-	-
16	49	500	7 CBR	-	-	-	-	-	-	-
24	74	750	8 CBR	-	-	-	-	-	-	-
33	99	1000	8 CBR	-	-	-	-	-	-	-
49	149	1500	9 CBR	-	-	-	-	-	-	-
66	199	2000	9 CBR	-	-	-	-	-	-	-
99	299	3000	10 CBR	-	-	-	-	-	-	-
133	399	4000	10 CBR	-	-	-	-	-	-	-
166	499	5000	11 CBR	4. IN	-	-	-	-	-	-
333	999	10000	12 CBR	4.5 IN	4. IN	-	-	-	-	-
499	1499	15000	13 CBR	5. IN	4.5 IN	4. IN	-	-	-	-
833	2499	25000	15 CBR	5. IN	5. IN	4.5 IN	4. IN	-	-	-
1666	4999	50000	16 CBR	5.5 IN	5. IN	5. IN	4.5 IN	4.5 IN	4. IN	-
3333	9999	100000+	17 CBR	6. IN	5.5 IN	5. IN	5. IN	4.5 IN	4.5 IN	4. IN

NOTE: 1x Cycle represents = single aircraft landing+All Taxi/Back taxi and Apron taxi included+takeoff \*CBRs are rounded up to nearest whole CBR / \*\*Thickness is rounded up to nearest 1/2 inch

Type Aircraft	Single Use Min Pass Level	Demonstrated Min Pass Level	Cycle/Pass after Min	Contingency	No Maintenance Factor Adjustment to PW PASSES
C-17	60	-	10	Contingency	3
C-130	10	-	10	Sustainment	2
* LTFW	20	200	10	Permanent	1

Table A9.10. C-145 Semi-Prepared Operations Planning Chart.

INCHES (IN)			Unpaved or Semi-Prepared Strength Requirements for Planning and Operational Determinations (Built using PCASE 2.09.05) C-145 (main 78 psi/nose 85 psi) @ 16,532 lbs										
Real World Conditions Use MOST of the time to plan or determine use	Optimum Conditions Very rarely used to plan or determine use	Perfect Conditions Should not be used to plan or determine use	SURFACE CBR REQUIRED	THICKNESS REQUIRED OVER CBR 2	THICKNESS REQUIRED OVER CBR 3	THICKNESS REQUIRED OVER CBR 4	THICKNESS REQUIRED OVER CBR 5	THICKNESS REQUIRED OVER CBR 6	THICKNESS REQUIRED OVER CBR 7	THICKNESS REQUIRED OVER CBR 8	THICKNESS REQUIRED OVER CBR 9	THICKNESS REQUIRED OVER CBR 10	THICKNESS REQUIRED OVER CBR 11
Cycles NO Maintenance	Cycles with Maintenance	PASSES (Engineering / PCASE)											
0	0	10	NO GO	NO GO	NO GO	NO GO	NO GO	NO GO	NO GO	NO GO	NO GO	NO GO	NO GO
0	1	20	3. CBR	4. IN	-	-	-	-	-	-	-	-	-
1	4	50	4. CBR	4. IN	-	-	-	-	-	-	-	-	-
2	6	75	4. CBR	4.5 IN	4 IN	-	-	-	-	-	-	-	-
3	9	100	4. CBR	5. IN	4 IN	-	-	-	-	-	-	-	-
4	14	150	4. CBR	5.5 IN	5 IN	4 IN	-	-	-	-	-	-	-
6	19	200	4. CBR	5.5 IN	4.5 IN	4. IN	-	-	-	-	-	-	-
9	29	300	5. CBR	6. IN	5. IN	4. IN	-	-	-	-	-	-	-
13	39	400	5. CBR	6.5 IN	5. IN	4.5 IN	4. IN	-	-	-	-	-	-
16	49	500	5 CBR	7. IN	5.5 IN	4.5 IN	4. IN	-	-	-	-	-	-
24	74	750	5 CBR	7. IN	5.5 IN	5. IN	4. IN	-	-	-	-	-	-
33	99	1000	6 CBR	7.5 IN	6. IN	5. IN	4.5 IN	4. IN	-	-	-	-	-
49	149	1500	6 CBR	8. IN	6.5 IN	5.5 IN	5. IN	4. IN	-	-	-	-	-
66	199	2000	6 CBR	8. IN	7. IN	6. IN	5. IN	4. IN	-	-	-	-	-
99	299	3000	7 CBR	9. IN	7. IN	6. IN	5.5 IN	5. IN	4. IN	-	-	-	-
133	399	4000	7 CBR	9. IN	7.5 IN	6. IN	5.5 IN	5. IN	4. IN	-	-	-	-
166	499	5000	7 CBR	9.5 IN	7.5 IN	6.5 IN	6. IN	5. IN	4. IN	-	-	-	-
333	999	10000	8 CBR	10. IN	8. IN	7. IN	6. IN	5.5 IN	5. IN	4. IN	-	-	-
499	1499	15000	8 CBR	10.5 IN	8.5 IN	7.5 IN	6.5 IN	6. IN	5.5 IN	4. IN	-	-	-
833	2499	25000	9 CBR	11. IN	9. IN	8. IN	7. IN	6. IN	5.5 IN	5. IN	4. IN	-	-
1666	4999	50000	10 CBR	12. IN	9.5 IN	8. IN	7. IN	6.5 IN	6. IN	5.5 IN	5. IN	4. IN	-
3333	9999	100000+	11 CBR	12.5 IN	10. IN	8.5 IN	8. IN	7. IN	6.5 IN	6. IN	5.5 IN	5. IN	4. IN

NOTE: 1x Cycle represents = single aircraft landing+All Taxi(Back taxi and Apron taxi included)+takeoff \*CBRs are rounded up to nearest whole CBR / \*\*Thickness is rounded up to nearest 1/2 inch

Type Aircraft	Single Use Min Pass Level	Demonstrated Min Pass Level	Cycle/Pass after Min	No Maintenance Factor Adjustment to PW PASSES
C-17	60	-	10	Contingency 3
C-130	10	-	10	Sustainment 2
* LTFW	20	200	10	Permanent 1

Note: \* 200 Demonstrated Min Pass Level is in reference to LTFW based on C-145

Table A9.11. PC-12 or U-28 Semi-Prepared Operations Planning Chart.

INCHES (IN)			Unpaved or Semi-Prepared Strength Requirements for Planning and Operational Determinations (Built using PCASE 2.09.05) PC-12 or U-28a (main 63 psi/nose 63 psi) @ 10,450 lbs									
Real World Conditions Use MOST of the time to plan or determine	Optimum Conditions Very rarely used to plan or determine use	Perfect Conditions Should not be used to plan or determine use	SURFACE CBR REQUIRED	THICKNESS REQUIRED OVER CBR 2	THICKNESS REQUIRED OVER CBR 3	THICKNESS REQUIRED OVER CBR 4	THICKNESS REQUIRED OVER CBR 5	THICKNESS REQUIRED OVER CBR 6	THICKNESS REQUIRED OVER CBR 7	THICKNESS REQUIRED OVER CBR 8	THICKNESS REQUIRED OVER CBR 9	THICKNESS REQUIRED OVER CBR 10
Cycles NO Maintenance	Cycles with Maintenance	PASSES (Engineering / PCASE)										
0	0	10	NO GO	NO GO	NO GO	NO GO	NO GO	NO GO	NO GO	NO GO	NO GO	NO GO
0	1	20	2 CBR	4 IN	-	-	-	-	-	-	-	-
1	4	50	3 CBR	4 IN	-	-	-	-	-	-	-	-
2	6	75	3 CBR	4 IN	-	-	-	-	-	-	-	-
3	9	100	3 CBR	4 IN	-	-	-	-	-	-	-	-
4	14	150	3 CBR	4 IN	-	-	-	-	-	-	-	-
6	19	200	3 CBR	4.5 IN	4 IN	-	-	-	-	-	-	-
9	29	300	3 CBR	5 IN	4 IN	-	-	-	-	-	-	-
13	39	400	4 CBR	5 IN	4 IN	-	-	-	-	-	-	-
16	49	500	4 CBR	5 IN	4 IN	-	-	-	-	-	-	-
24	74	750	4 CBR	5.5 IN	4.5 IN	4 IN	-	-	-	-	-	-
33	99	1000	4 CBR	6 IN	5 IN	4 IN	-	-	-	-	-	-
49	149	1500	4 CBR	6 IN	5 IN	4 IN	-	-	-	-	-	-
66	199	2000	4 CBR	6.5 IN	5 IN	4.5 IN	4 IN	-	-	-	-	-
99	299	3000	5 CBR	7 IN	5.5 IN	4.5 IN	4 IN	-	-	-	-	-
133	399	4000	5 CBR	7 IN	5.5 IN	5 IN	4 IN	-	-	-	-	-
166	499	5000	5 CBR	7.5 IN	6 IN	5 IN	4 IN	-	-	-	-	-
333	999	10000	6 CBR	8 IN	6.5 IN	5.5 IN	5 IN	4 IN	-	-	-	-
499	1499	15000	6 CBR	8.5 IN	6.5 IN	5.5 IN	5 IN	4 IN	-	-	-	-
833	2499	25000	7 CBR	9 IN	7 IN	6 IN	5.5 IN	4.5 IN	4 IN	-	-	-
1666	4999	50000	7 CBR	9.5 IN	7.5 IN	6.5 IN	5.5 IN	5 IN	4 IN	4 IN	-	-
3333	9999	100000+	8 CBR	10 IN	8 IN	7 IN	6 IN	5.5 IN	5 IN	4 IN	-	-

NOTE: 1x Cycle represents = single aircraft landing\*All Taxi(Back taxi and Apron taxi included)+takeoff \*CBRs are rounded up to nearest whole CBR / \*\*Thickness is rounded up to nearest 1/2 inch

Type Aircraft	Single Use Min Pass Level	Demonstrated Min Pass Level	Cycle/Pass after Min	No Maintenance Factor Adjustment to PW PASSES
C-17	60	-	10	Contingency 3
C-130	10	-	10	Sustainment 2
* LTFW	20	200	10	Permanent 1

Note: \* 200 Demonstrated Min Pass Level is in reference to LTFW based on C-146

Table A9.12. A-10 Semi-Prepared Operations Planning Chart.

INCHES (IN)			Unpaved or Semi-Prepared Strength Requirements for Planning and Operational Determinations (Built using PCASE 2.09.05) A-10 (main 185 psi/nose 140 psi) @ 50,000 lbs									
Real World Conditions Use MOST of the time to plan or determine use	Optimum Conditions Very rarely used to plan or determine use	Perfect Conditions Should not be used to plan or determine use	SURFACE CBR REQUIRED	THICKNESS REQUIRED OVER CBR 2	THICKNESS REQUIRED OVER CBR 3	THICKNESS REQUIRED OVER CBR 4	THICKNESS REQUIRED OVER CBR 5	THICKNESS REQUIRED OVER CBR 6	THICKNESS REQUIRED OVER CBR 7	THICKNESS REQUIRED OVER CBR 8	THICKNESS REQUIRED OVER CBR 9	THICKNESS REQUIRED OVER CBR 10
Cycles NO Maintenance	Cycles with Maintenance	PASSES (Engineering / PCASE)										
0	0	10	NO GO	NO GO	NO GO	NO GO	NO GO	NO GO	NO GO	NO GO	NO GO	NO GO
0	1	20	9. CBR	5.5 IN	4.5 IN	4. IN	-	-	-	-	-	-
0	2	75	11. CBR	8. IN	6.5 IN	6. IN	5. IN	4.5 IN	4. IN	-	-	-
1	5	100	12. CBR	9. IN	7. IN	6. IN	6. IN	5. IN	5. IN	4. IN	-	-
5	15	200	13 CBR	10. IN	8. IN	7. IN	6.5 IN	6. IN	5.5 IN	5. IN	4.5 IN	4.5 IN
8	25	300	14 CBR	11. IN	9. IN	7.5 IN	7. IN	6. IN	6. IN	5.5 IN	5. IN	4.5 IN
11	35	400	15 CBR	11.5 IN	9.5 IN	8. IN	7. IN	6.5 IN	6. IN	5.5 IN	5. IN	5. IN
15	45	500	15 CBR	12. IN	10. IN	9. IN	8. IN	7. IN	6. IN	6. IN	6. IN	5. IN
23	70	750	17 CBR	13. IN	10.5 IN	9. IN	8. IN	7. IN	6.5 IN	6. IN	6. IN	5.5 IN
31	95	1000	17 CBR	13.5 IN	11. IN	9.5 IN	8.5 IN	7.5 IN	7. IN	6.5 IN	6. IN	6. IN
48	145	1500	19 CBR	14. IN	11.5 IN	10. IN	9. IN	8. IN	7.5 IN	7. IN	6.5 IN	6. IN
65	195	2000	19 CBR	14.5 IN	12. IN	10.5 IN	9. IN	8.5 IN	8. IN	7. IN	6.5 IN	6.5 IN
98	295	3000	21 CBR	15.5 IN	13. IN	11. IN	9.5 IN	9. IN	8. IN	7.5 IN	7. IN	6.5 IN
131	395	4000	22 CBR	16. IN	13. IN	11.5 IN	10. IN	9. IN	8.5 IN	8. IN	7.5 IN	7. IN
166	499	5000	22 CBR	17. IN	14. IN	12. IN	11. IN	10. IN	9. IN	8. IN	8. IN	7. IN
1665	4995	50000	32 CBR	21. IN	18. IN	15. IN	13. IN	12. IN	11. IN	10. IN	10. IN	9. IN
3331	9995	100000	36 CBR	23. IN	19. IN	16. IN	14. IN	13. IN	12. IN	11. IN	10. IN	10. IN

NOTE: 1x Cycle represents = single aircraft landing+All Taxi(Back taxi and Apron taxi included)+takeoff \*CBRs are rounded up to nearest whole CBR / \*\*Thickness is rounded up to nearest 1/2 inch

Type Aircraft	Single Use Min Pass Level	Demonstrated Min Pass Level	Cycle/Pass after Min	No Maintenance Factor Adjustment to PW PASSES
C-17	60	-	10	Contingency 3
C-130	10	-	10	Sustainment 2
* LTFW	20	200	10	Permanent 1

Note: \* 200 Demonstrated Min Pass Level is in reference to LTFW based on C-148

Table A9.13. AT-6 Semi-Prepared Operations Planning Chart.

INCHES (IN)			Unpaved or Semi-Prepared Strength Requirements for Planning and Operational Determinations (Built using PCASE 2.09.06) AT-6 (main 220 psi/nose 120 psi) @ 10,000 lbs										
Real World Conditions Use MOST of the time to plan or determine	Optimum Conditions Very rarely used to plan or determine use	Perfect Conditions Should not be used to plan or determine use	SURFACE CBR REQUIRED	THICKNESS REQUIRED OVER CBR 2	THICKNESS REQUIRED OVER CBR 3	THICKNESS REQUIRED OVER CBR 4	THICKNESS REQUIRED OVER CBR 5	THICKNESS REQUIRED OVER CBR 6	THICKNESS REQUIRED OVER CBR 7	THICKNESS REQUIRED OVER CBR 8	THICKNESS REQUIRED OVER CBR 9	THICKNESS REQUIRED OVER CBR 10	THICKNESS REQUIRED OVER CBR 11
Cycles NO Maintenance	Cycles with Maintenance	PASSES (Engineering / PCASE)											
0	0	10	NO GO	NO GO	NO GO	NO GO	NO GO	NO GO	NO GO	NO GO	NO GO	NO GO	NO GO
0	1	20	7. CBR	4. IN	-	-	-	-	-	-	-	-	-
1	4	50	8. CBR	4. IN	-	-	-	-	-	-	-	-	-
2	6	75	8. CBR	4. IN	-	-	-	-	-	-	-	-	-
3	9	100	9. CBR	4. IN	-	-	-	-	-	-	-	-	-
4	14	150	9. CBR	4. IN	-	-	-	-	-	-	-	-	-
6	19	200	10. CBR	4. IN	-	-	-	-	-	-	-	-	-
9	29	300	10. CBR	4. IN	-	-	-	-	-	-	-	-	-
13	39	400	11. CBR	4.5 IN	4. IN	-	-	-	-	-	-	-	-
16	49	500	11 CBR	4.5 IN	4. IN	-	-	-	-	-	-	-	-
24	74	750	12 CBR	5. IN	4. IN	-	-	-	-	-	-	-	-
33	99	1000	12 CBR	5. IN	4. IN	-	-	-	-	-	-	-	-
49	149	1500	13 CBR	5.5 IN	4.5 IN	4. IN	-	-	-	-	-	-	-
66	199	2000	14 CBR	6. IN	5. IN	4. IN	-	-	-	-	-	-	-
99	299	3000	15 CBR	6. IN	5. IN	4.5 IN	4. IN	-	-	-	-	-	-
133	399	4000	15 CBR	6.5 IN	5.5 IN	4.5 IN	4. IN	-	-	-	-	-	-
166	499	5000	16 CBR	6.5 IN	5.5 IN	5. IN	4. IN	-	-	-	-	-	-
333	999	10000	18 CBR	7. IN	6. IN	5. IN	4.5 IN	4. IN	-	-	-	-	-
499	1499	15000	19 CBR	7.5 IN	6. IN	5.5 IN	5. IN	4.5 IN	4. IN	-	-	-	-
833	2499	25000	21 CBR	8. IN	6.5 IN	5.5 IN	5. IN	4.5 IN	4. IN	-	-	-	-
1666	4999	50000	23 CBR	8.5 IN	7. IN	6. IN	5.5 IN	5. IN	4.5 IN	4. IN	-	-	-
3333	9999	100000+	26 CBR	9.5 IN	7.5 IN	6.5 IN	6. IN	5.5 IN	5. IN	4.5 IN	4. IN	-	-

NOTE: 1x Cycle represents = single aircraft landing+All Taxi(Back taxi and Apron taxi included)+takeoff \*CBRs are rounded up to nearest whole CBR / \*\*Thickness is rounded up to nearest 1/2 inch

Type Aircraft	Single Use Min Pass Level	Demonstrated Min Pass Level	Cycle/Pass after Min	No Maintenance Factor Adjustment to PW PASSES
C-17	60	-	10	Contingency
C-130	10	-	10	Sustainment
* LTFW	20	200	10	Permanent

Note: \* 200 Demonstrated Min Pass Level is in reference to LTFW based on C-148



Table A9.14. A-29 Semi-Prepared Operations Planning Chart.

INCHES (IN)			Unpaved or Semi-Prepared Strength Requirements for Planning and Operational Determinations (Built using PCASE 2.09.06) A-29 (main 75 psi/nose 65 psi) @ 11,904 lbs										
Real World Conditions Use MOST of the time to plan or determine	Optimum Conditions Very rarely used to plan or determine use	Perfect Conditions Should not be used to plan or determine use	SURFACE CBR REQUIRED	THICKNESS REQUIRED OVER CBR 2	THICKNESS REQUIRED OVER CBR 3	THICKNESS REQUIRED OVER CBR 4	THICKNESS REQUIRED OVER CBR 5	THICKNESS REQUIRED OVER CBR 6	THICKNESS REQUIRED OVER CBR 7	THICKNESS REQUIRED OVER CBR 8	THICKNESS REQUIRED OVER CBR 9	THICKNESS REQUIRED OVER CBR 10	THICKNESS REQUIRED OVER CBR 11
Cycles NO Maintenance	Cycles with Maintenance	PASSES (Engineering / PCASE)		NO GO	NO GO	NO GO	NO GO	NO GO	NO GO	NO GO	NO GO	NO GO	NO GO
0	0	10	NO GO	NO GO	NO GO	NO GO	NO GO	NO GO	NO GO	NO GO	NO GO	NO GO	NO GO
0	1	20	3. CBR	4. IN	-	-	-	-	-	-	-	-	-
1	4	50	3. CBR	4. IN	-	-	-	-	-	-	-	-	-
2	6	75	3. CBR	4. IN	-	-	-	-	-	-	-	-	-
3	9	100	3. CBR	4. IN	-	-	-	-	-	-	-	-	-
4	14	150	4. CBR	4.5 IN	4. IN	-	-	-	-	-	-	-	-
6	19	200	4. CBR	4.5 IN	4. IN	-	-	-	-	-	-	-	-
9	29	300	4. CBR	5. IN	4. IN	-	-	-	-	-	-	-	-
13	39	400	4. CBR	5. IN	4. IN	-	-	-	-	-	-	-	-
16	49	500	4 CBR	5.5 IN	4.5 IN	4. IN	-	-	-	-	-	-	-
24	74	750	4 CBR	6. IN	4.5 IN	4. IN	-	-	-	-	-	-	-
33	99	1000	5 CBR	6. IN	5. IN	4.5 IN	4. IN	-	-	-	-	-	-
49	149	1500	5 CBR	6.5 IN	5. IN	4.5 IN	4. IN	-	-	-	-	-	-
66	199	2000	5 CBR	7. IN	5.5 IN	4.5 IN	4. IN	-	-	-	-	-	-
99	299	3000	6 CBR	7. IN	6. IN	5. IN	4.5 IN	4. IN	-	-	-	-	-
133	399	4000	6 CBR	7.5 IN	6. IN	5. IN	4.5 IN	4. IN	-	-	-	-	-
166	499	5000	6 CBR	7.5 IN	6. IN	5.5 IN	5. IN	4. IN	-	-	-	-	-
333	999	10000	7 CBR	8.5 IN	7. IN	6. IN	5. IN	4.5 IN	4. IN	-	-	-	-
499	1499	15000	7 CBR	8.5 IN	7. IN	6. IN	5.5 IN	5. IN	4. IN	-	-	-	-
833	2499	25000	8 CBR	9. IN	7.5 IN	6.5 IN	5.5 IN	5. IN	4.5 IN	4. IN	-	-	-
1666	4999	50000	9 CBR	10. IN	8. IN	7. IN	6. IN	5.5 IN	5. IN	4.5 IN	4. IN	-	-
3333	9999	100000+	10 CBR	10.5 IN	8.5 IN	7. IN	6.5 IN	6. IN	5. IN	5. IN	4.5 IN	4. IN	-

NOTE: 1x Cycle represents = single aircraft landing+All Taxi(back taxi and Apron taxi included)+takeoff! \*CBRs are rounded up to nearest whole CBR / \*\*Thickness is rounded up to nearest 1/2 inch

Type Aircraft	Single Use Min Pass Level	Demonstrated Min Pass Level	Cycle/Pass after Min	No Maintenance Factor Adjustment to PW PASSES
C-17	60	-	10	Contingency
C-130	10	-	10	Sustainment
* LTFW	20	200	10	Permanent

Note: \* 200 Demonstrated Min Pass Level is in reference to LTFW based on C-141

**A9.4. LZ Skid Test Procedures.** In the absence of pilot reported RCR/braking action, the goal of conducting the skid tests is to accurately characterize the on-site friction supply (or skid resistance) of an unpaved airfield. Layout an adequate number of skid tests to be conducted in several locations on the airfield that, when averaged, will adequately represent the skid resistance of the runway surface. (T-2). Time permitting, and/or as required, eight tests are recommended for the typical contingency airfield (4000'x90', Figure A9.4, as an example) which should take approximately a half hour:

Figure A9.4. Layout Skid Test Locations.

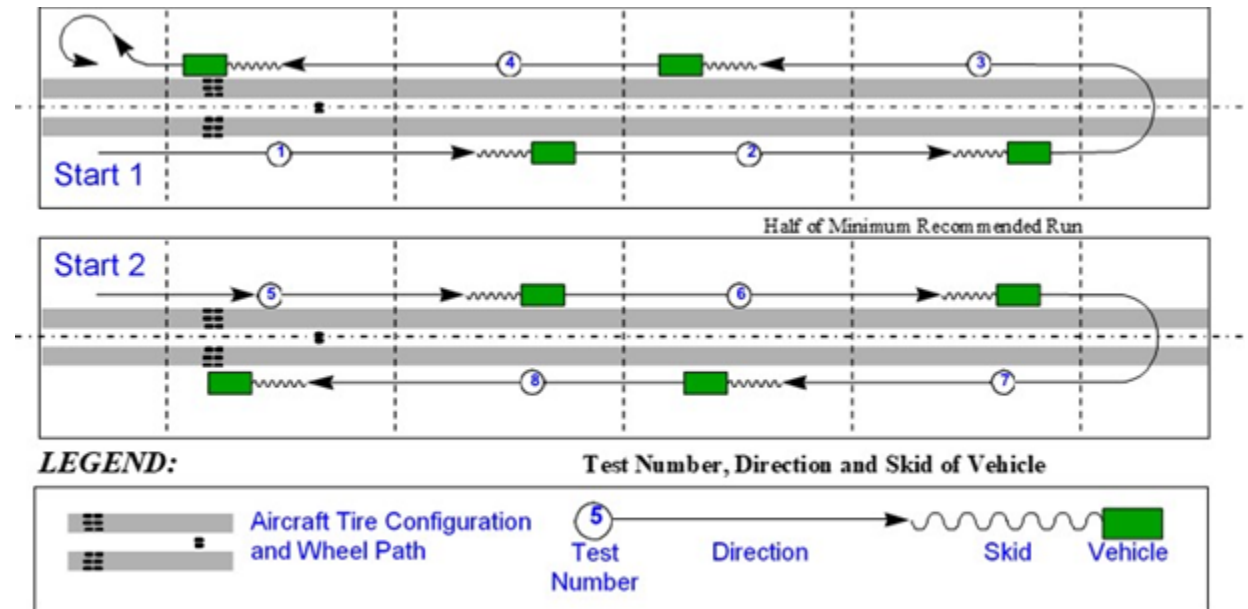

A9.4.1. Target speed at braking will always be 20 MPH and ensure enough space for run-up. (T-2). At braking locations, push on the brake as hard as possible to lock up all four tires and then skid to a complete stop (may require turning off ABS. Use of e-brake in conjunction with braking may also highlight effective skid-mark.) For the cycle and ATVs, lock up the BACK BRAKES ONLY, as it is unsafe to lock up both the front and back brakes. Use [Table A9.13](#) to report average.

**Table A9.15. Estimated Unpaved RCR/ICAO Braking Action.**

Test Vehicle Stop Distance(')	RCR	ICAO Braking Action
1-22	20	Good
23-25	16	Good
25-30	14	Good
31-35	12	Medium
36-40	10	Medium
41-45	9	Med to Poor
46-50	8	Med to Poor
51-60	7	Poor
61-70	6	Nil
71-85	5	Nil
86-100	4	Nil
Notes		
This checklist groups RCR and correlates that group to the most restrictive value in that group.		

**Table A9.16. Estimated Paved RCAM.**

**B-22 NATL/INTL FLIGHT DATA/PROCEDURES**

**5. RUNWAY CONDITION READING (RCR) CORRELATION CHART**

(AFFSA-Afld Mgmt Ops/AFFSA-Afld Mgmt Ops FIL 14-884)

**NOTE:** Joint USAF/NASA tests have proven RCR measurements invalid where the only form of moisture affecting the runway is water. Readings taken during such conditions will be reported as Wet Runway - WR. Measurements taken when water or slush is present on an ice covered runway will be reported as RCR 12 or the measured decelerometer reading, whichever is lower.

Runway Condition Reading (RCR)	Percent Increase In Landing Roll
02 to 05	100 or more
06 to 12	99 to 46
13 to 18	45 to 16
19 to 25	15 to 0

**Runway Condition Assessment Matrix (RCAM)**

Assessment Criteria	Downgrade Assessment Criteria				
Runway Condition Description	Runway Condition Code	Mu Reading	Vehicle Deceleration or Directional Control Observation	Pilot Reported Braking Action	Runway Condition Reading (RCR) Value*
• Dry	6	.46 or Higher	---	---	23-26
• Frost • Wet (includes Damp and 1/8" depth or less of Water) <b>1/8" (3mm) depth or less of:</b> • Slush • Dry Snow • Wet Snow	5	.40 - .45	Braking deceleration is normal for the wheel braking effort applied AND directional control is normal.	Good	14-22
<b>5° F (-15° C) and colder outside air temperature:</b> • Compacted Snow	4	.37 - .39	Braking deceleration OR directional control is between Good and Medium.	Good to Medium	13
• Slippery when wet (wet runway) • Dry Snow or Wet Snow (any depth) over Compacted Snow <b>Greater than 1/8" (3 mm) depth of:</b> • Dry Snow • Wet Snow <b>Warmer than 5° F (-15° C) outside air temperature:</b> • Compacted Snow	3	.30 - .36	Braking deceleration is noticeably reduced for the wheel braking effort applied OR directional control is noticeably reduced.	Medium	10-12
<b>Greater than 1/8" (3 mm) depth of:</b> • Water • Slush	2	.26 - .29	Braking deceleration OR directional control is between Medium and Poor.	Medium to Poor	8-9
• Ice	1	.21 - .25	Braking deceleration is significantly reduced for the wheel braking effort applied OR directional control is significantly reduced.	Poor	7
• Wet Ice • Slush over Ice • Water on top of Compacted Snow	0	0 - .20	Braking deceleration is minimal to non-existent for the wheel braking effort applied OR directional control is uncertain.	Nil	0-6

**A9.5. SPACI and RFF Procedures.**

A9.5.1. Step 1. Divide the entire field into sections and sample areas. Each sample area located on the runway or taxiway may be 250 feet long and the width of the runway or taxiway. Make the hammerheads and overruns each be a section. Divide the aprons into sections of approximately 25,000 square feet. Example in [Figure A9.5](#)

**Figure A9.5. Semi-prepared Airfield Layout.**

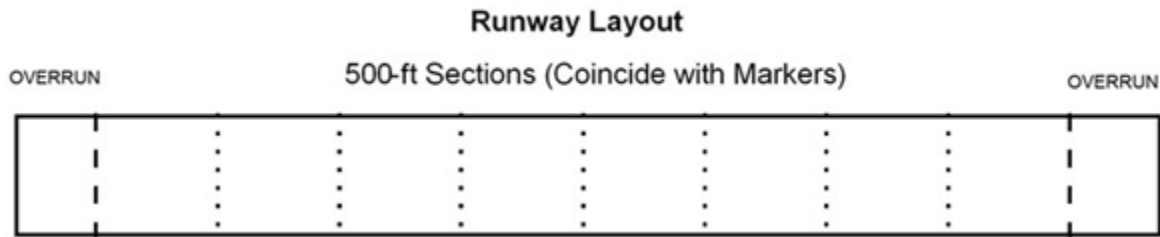

A9.5.2. Step 2. Select sample areas to inspect. As a minimum for contingency operations, inspect the sections in the touchdown area, in the primary braking area at approximately 1000 to 1500 feet, at the point of aircraft rotation at approximately 2000 to 2500 feet and at the last 500 feet of the runway. (The point of rotation may move due to pressure and altitude changes.) These sections include the areas most likely to be damaged by landing, braking, stopping, acceleration and takeoff for the runway in use. Inspect and monitor additional areas where degradation develops.

A9.5.3. Step 3. Inspect sample areas and record any identified distresses as in [figure A9.6](#) Conduct as detailed and accurate an inspection as time and conditions permit. Note all distresses and the appropriate severity levels for each, see [table A9.15](#).

**Figure A9.6. SPACI Sample Survey.**

Distress Type	91	92	93	94	95	96	97
Severity	G		✓				
	A		✓	✓	✓		
	R						

**Table A9.17. Surface Distress Conditions.**

C-17 on Semi-prepared and Unprepared Surfaces			
Distress Types	Green	Amber	Red
Potholes	< 4 inches deep and/or < 15 inches in diameter	4 to 9 inches deep and > 15 inches in diameter	> 9 inches deep and > 15 inches in diameter
Loose aggregate coverage	Covers < 1/10 of section	Covers between 1/10 and 1/2 of section	Covers > 1/2 of section
Loose aggregate size	Max. < 3/4 inch diameter, Recommended < 1/2 inch	Max. = 3/4 inch to 1 inch diameter	Max. > 1 inch diameter
Ruts	Exist but < 4 inches deep	4 to 9 inches deep	> 9 inches deep
RRM	Exist but < 3.5 inches deep	3.5 to 7.75 inches deep	> 7.75 inches deep
Dust	Does not obstruct visibility	Partially obstructs visibility	Thick; obstructs visibility
Jet blast erosion	Exist but < 1 inch deep	1 to 3 inches deep	> 3 inches deep
Stabilized layer failure	Exist but < 1 inch deep	1 to 2 inches deep	> 2 inches deep
C-130 on Semi-prepared and Unprepared Surfaces			

Distress Types	Green	Amber	Red
Potholes	< 4 inches deep and/or < 15 inches in diameter	4 to 6 inches deep and > 15 inches in diameter	> 6 inches deep and > 15 inches in diameter
Loose aggregate coverage	Covers < 1/10 of section	Covers between 1/10 and 1/2 of section	Covers > 1/2 of section
Loose aggregate size	Max. < 3/4 inch diameter, Recommended < 1/2 inch	Max. = 3/4 inch to 1 inch diameter	Max. > 1 inch diameter
Ruts	Exist but < 3 inches deep	3 to 6 inches deep	> 6 inches deep
RRM	Exist but < 1 inch deep	1 to 3 inches deep	> 3 inches deep
Dust	Does not obstruct visibility	Partially obstructs visibility	Thick; obstructs visibility
Jet blast erosion	Exist but < 1 inch deep	1 to 3 inches deep	> 3 inches deep
Stabilized layer failure	Exist but < 1 inch deep	1 to 2 inches deep	> 2 inches deep
C-146/LTFW on Semi-prepared and Unprepared Surfaces			
Distress Types	Green	Amber	Red
Potholes	< 3 inches deep and/or < 15 inches in diameter	3 to 5 inches deep and/or > 15 inches in diameter	> 5 inches deep and/or > 15 inches in diameter
Loose aggregate coverage	Covers < 1/10 of section	Covers between 1/10 and 1/2 of section	Covers > 1/2 of section
Loose aggregate size	Max. < 3/4 inch diameter, Recommended < 1/2 inch	Max. = 3/4 inch to 1 inch diameter	Max. > 1 inch diameter
Ruts	Exist but < 1 inch deep	3 to 5 inches deep	> 5 inches deep
RRM	Exist but < 1 inch deep	1 to 2 inches deep	> 2 inches deep
Dust	Does not obstruct visibility	Partially obstructs visibility	Thick; obstructs visibility
Jet blast erosion	Exist but < 3/4 inch deep	≤ 1 inch deep	> 1 inch deep
Stabilized layer failure	Exist but < 3/4 inch deep	≤ 1 inch deep	> 1 inch deep
<b>Notes:</b> These limits are based upon tests of soils in arid environments and may be too high for soils in more humid environments. Potholes, ruts and RRM are considered major distresses. Depending upon actual distress location, any distress types categorized as Red may cause the overall condition of the airfield to be Red.			
All Airframes on Surface-Treatment and Macadam Surfaces			
Distress Types	Green	Amber	Red
Potholes	< 1 inch deep and/or < 15 inches in diameter	1 to 2 inches deep and > 15 inches in diameter	> 2 inches deep and > 15 inches in diameter
Ruts	Exist but < 1 inch deep	1 to 3 inches deep	> 3 inches deep

Loose Aggregate	Binder is wearing away causing low FOD potential over < 10% of surface, surface mostly intact.	Fine aggregate is missing and larger pieces are dislodged. Moderate FOD potential. Surface is rough and pitted with loose aggregate covering between 10 and 50% of the surface.	High FOD potential. Surface texture is very rough and pitted. Loose aggregate covering > 50% of the surface
Dust	Does not obstruct visibility	Partially obstructs visibility	Thick, obstructs visibility
Rolling Resistant Material	Exist but < 1 inch deep	1 to 3 inches deep	> 3 inches deep
Jet Blast Erosion	Exist but < 1 inch deep	1 to 3 inches deep	> 3 inches deep
Stabilized Layer Failure	Exist but < 1 inch deep	1 to 2 inches deep	> 2 inches deep
<p><b>Notes:</b> If the pavement section is in relatively good condition with only low-severity distresses scattered across the section, which does not require more than routine maintenance to maintain aircraft operations, the pavement is considered in Green (good) condition. However, if medium-severity distresses were present in addition to the low-severity distresses, or the section requires routine to major repair to maintain operations, then rate the section Amber (fair). If high-severity distresses are prevalent, and the pavement requires constant maintenance and repairs to maintain operations, then consider the pavement Red (poor). When the condition of the airfield approaches Red inspect it before and after each aircraft operation.</p>			

A9.5.4. Step 4. Assign distress deduct values to each distress type identified, Total the distress educt values, and compute sample area SPACI, see **Figures A9.6 and Figure A9.7** The deduct values for sections located on the runway/taxiway are different than the deduct values for sections located on aprons/hammerheads.

**Figure A9.7. Assigning SPACI Distress Deduct Values.**

Distress Type	Severity	Deduct Value
91	● ● ●	
92	● ● ●	18
93	● ● ●	4
94	● ● ●	4
95	● ● ●	22
96	● ● ●	
97	● ● ●	

Total Deduct Value = **48**

q = **2**

SPACI = **65**

Note: If any distress is red, the landing zone safety officer will determine the suitability for operations.



Figure A9.8. SPACI Distress Deduct Values.

**Deduct Values for C-17 Operations**

Distress	Green		Amber		Red	
	R/T*	H/A**	R/T	H/A	R/T	H/A
91 Potholes	4	2	10	6	20	12
92 Ruts	14	4	18	6	24	10
93 Loose Aggregate	4	15	6	30	8	45
94 Dust	2	15	4	30	6	45
95 Rolling Resistant Material	18	2	22	4	26	15
96 Jet Blast Erosion	5	10	10	30	15	40
97 Stabilized Layer Failure	5	15	10	25	15	35

\*R/T – runways and taxiways  
 \*\*H/A – hammerheads and aprons

A9.5.5. Step 5. Average sample area SPACI values to determine section SPACI. Example figure A9.9. If samples were inspected at the touchdown, maximum braking, turnaround and point of rotation areas on the runway and the individual sample area SPACI values were 63, 67, 55 and 71; the runway SPACI is 64.

Figure A9.9. SPACI Curves.

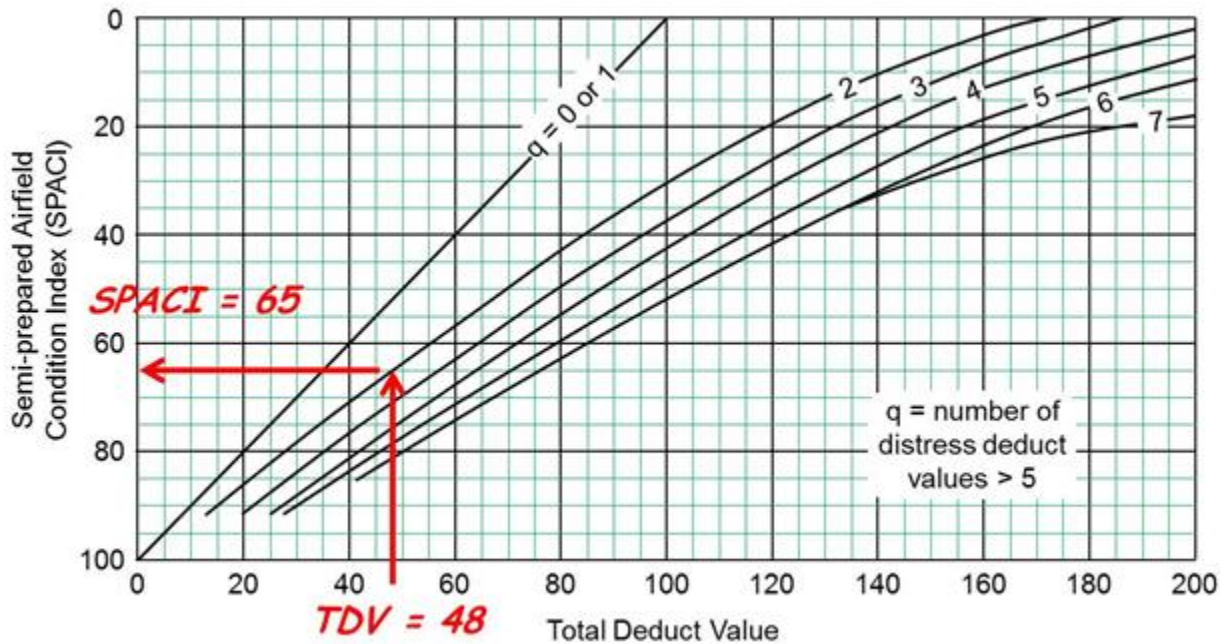

A9.5.6. Step 6. Average section SPACIs to determine airfield SPACI, if desired. A SPACI of 76 - 100 is rated “Green”. A SPACI of 26 – 75 is rated “Amber”. A SPACI of 0 - 25 is rated “Red”. Maintain training LZs in “Green” condition. Maintain contingency LZs in “Green” or “Amber” condition. Regardless of the overall SPACI rating, if any individual distress is rated as “Red”, the LZSO will determine the feasibility of each operation.

**Table A9.18. C-17 RFF Values.**

Semi-prepared Runway	Dry Till Depth	Rolling Friction Factor ( <b>Note 2</b> )	SPACI (Refer to <b>3.4.2.</b> )
Un-stabilized (dry)	0 to 1.5 inches	5	GREEN: use 10
	1.51 to 3.5 inches	10	
	3.51 to 5.75 inches	15	AMBER: use 20
	5.76 to 7.75 inches	20	
	> 7.75 inches	Maintenance or Waiver	RED: Waiver
Un-stabilized (wet)	0 to 1.0 inches	5	GREEN: use 5
	> 1.0 inches	Waiver	RED: Waiver
Cement Stabilized	0 to 0.5 inches	2	GREEN: use 15
	0.51 to 0.99	15	
	1 to 2 inches	20	AMBER: use 20
	> 2 inches	Maintenance or Waiver	RED: Waiver

**Note 1:** If RFF is unknown or conditions do not appear to match reported RFF, use 20.

**Note 2:** C-17 OPCON is rarely transferred from TRANSCOM. If 18<sup>th</sup> AF or a different Air Component Commander grants a waiver, they will notify the AMC/A3 of the waiver. (**T-1**)

## Attachment 10

## ADDITIONAL GUIDANCE CONCERNING DZS

## A10.1. MEW Procedures.

A10.1.1. Inflate the 10-gram balloon with helium to a circumference of 57 inches for day and 74 inches for night. Substitute two 60 inch balloons tied together if unable to inflate balloon to 74 inches. The increase in size at night compensates for the weight of a small marking light attached to the balloon.

A10.1.2. Two types of marking lights are authorized: One type activates upon immersion in water, then affixes to the balloon; the other type is commonly known as a chemical light and measures six inches in length. **NOTE:** Using a chemical light other than the 6-inch size will result in inaccurate mean effective wind measurement. (T-2).

A10.1.3. Time the balloon ascent from release to the required altitude. The ascension tables reflect the ascent times required for the balloon to reach various altitudes. This method is also used to estimate the base altitude of cloud layers by determining the ascension time for the balloon until obscured by the cloud base.

A10.1.4. During ascent, note unusual movement by the balloon; unusual movement indicates erratic wind conditions. Include the altitude of these occurrences, if significant, in the MEW report to the aircraft.

A10.1.5. When the balloon reaches drop altitude, measure the elevation angle using a pocket transit, theodolite, clinometer, or any other accurate means available.

A10.1.6. Measure the magnetic azimuth to the balloon, and note the reciprocal heading. The noted reciprocal heading is the MEW wind direction.

A10.1.7. Referring to the scale on the left side of **Table A10.1**, locate the angle that corresponds to the angle measured. Move horizontally across the table to the vertical column that corresponds to the drop altitude being used. The value at the intersection of these two lines is the MEW wind speed in knots.

A10.1.8. When transmitting the MEW, make sure to identify it as the “mean effective wind” and include the altitude to which it was taken. Phraseology: “TALON ZERO ONE, MEAN EFFECTIVE WIND AT (DROP ALTITUDE AGL), ESTIMATED THREE FIVE ZERO AT ONE NINER.” At that time, report any indication(s) of erratic winds or wind shear.

**Table A10.1. Mean Effective Wind Computation Table (10-Gram Helium Balloon).**

Conversion Chart For Elevation Changes To Wind Speed In Knots															
Day Circumference: 57", Night Circumference: 74"															
DROP ALTITUDE IN FEET															
		500	750	1000	1250	1500	1750	2000	2500	3000	3500	4000	4500	ASCENSION TABLE	
ELEVATION ANGLE	70	02	02	01	01	01	01	01	01	01	01	01	01	01	
	60	03	02	02	02	02	02	02	02	02	02	02	02	02	
	55	03	03	03	03	03	03	03	03	03	03	03	03	03	TIME

50	04	04	03	03	03	03	03	03	03	03	03	03	03	0:10	80
45	05	04	04	04	04	04	04	04	04	04	04	04	04	0:20	170
40	06	05	05	05	05	05	05	04	04	04	04	04	04	0:30	250
35	07	06	06	06	06	05	05	05	05	05	05	05	05	0:40	330
30	08	07	07	07	07	07	07	07	06	06	06	06	06	0:50	400
25	10	09	09	09	08	08	08	08	08	08	08	08	08	1:02	500
24	11	10	09	09	09	09	08	08	08	08	08	08	08	1:10	540
23	11	10	10	09	09	09	09	08	08	08	08	08	08	1:20	610
22	12	11	10	10	10	10	09	09	09	09	09	09	09	1:30	670
21	12	11	11	10	10	10	10	10	10	10	10	10	10	1:43	750
20	13	12	11	11	11	11	11	10	10	10	10	10	10	1:50	790
19	14	13	12	12	11	11	11	11	11	11	11	11	11	2:25	1000
18	15	13	13	12	12	12	12	12	11	11	11	11	11	2:44	1100
17	16	14	13	13	13	13	12	12	12	12	12	12	12	3:05	1250
16	17	15	14	14	14	13	13	13	13	13	13	13	13	3:49	1500
15	18	16	15	15	14	14	14	14	14	14	14	14	14	4:30	1750
14	19	17	16	16	16	15	15	15	15	15	15	15	15	5:11	2000
13	21	19	18	17	17	17	17	17	17	17	17	17	17	6:34	2500
12	22	20	19	19	18	18	18	18	17	17	17	17	17	7:58	3000
11	24	22	21	21	20	20	20	19	19	19	19	19	19	9:22	3500
10	27	25	23	23	22	22	22	21	21	21	21	21	21	10:44	4000
09	30	27	26	26	25	24	24	24	23	23	23	23	23	12:08	4500
<b>WIND SPEED IN KNOTS (10 GRAM BALLOON)</b>															

A10.2. Moving Target Procedures and Moving Target Pattern Instruction.

Figure A10.1. Jumpmaster Directed Airdrop, Moving Target Procedures.

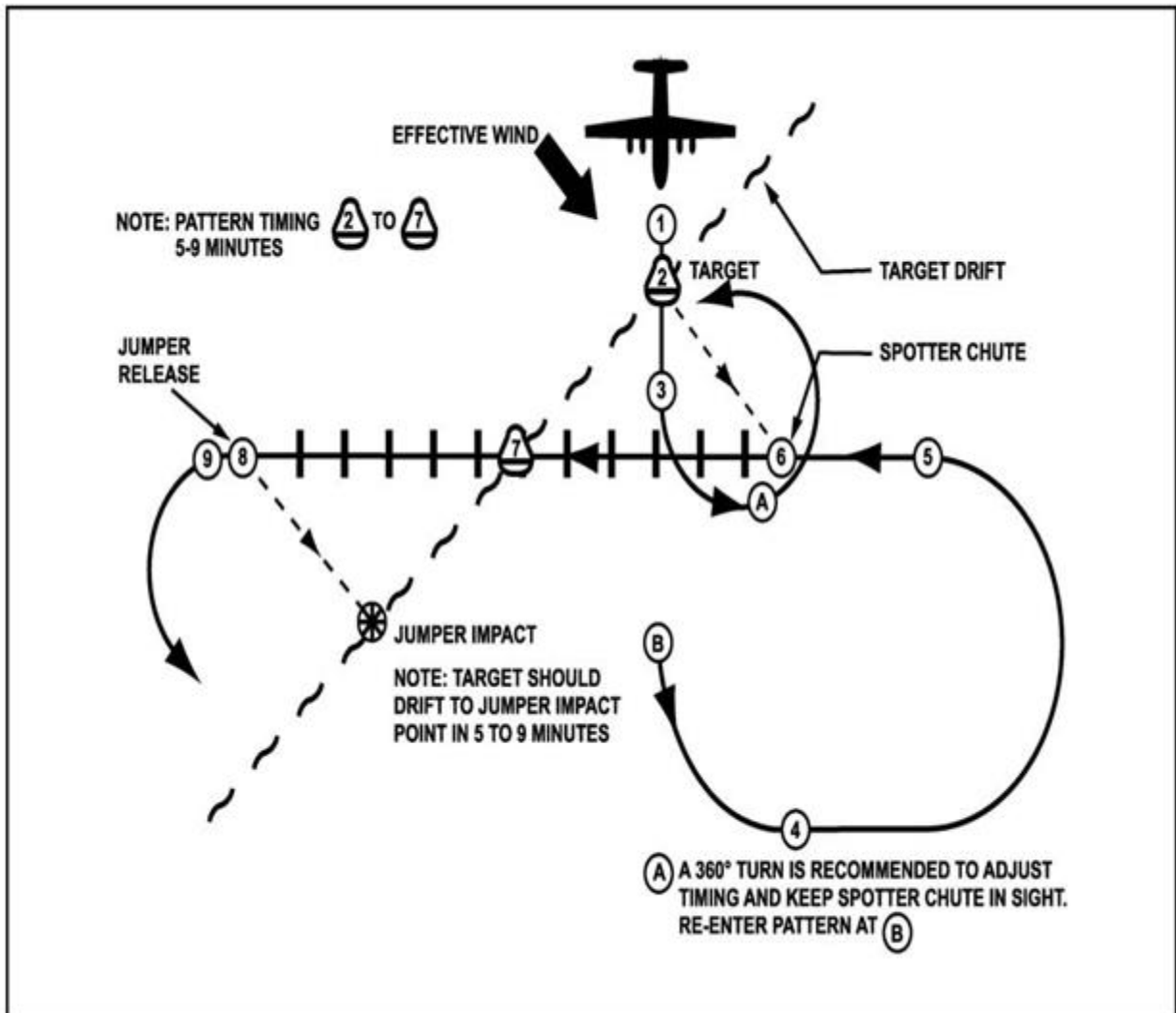

**MOVING TARGET PROCEDURES**

**Step 1.** Head directly toward the target, regardless of the wind direction.

**Step 2.** Release the spotter chute or wind drift indicator (WDI) directly over the target.

**Step 3.** Immediately upon release, make a left/right hand turn (see item A) to observe the descent and position of the spotter chute/WDI.

**Step 4.** Establish rectangular drop pattern oriented so the final approach aligns with the spotter chute/WDI and the target, respectively. **(T-2).** The pattern should be adjusted so that the aircraft will be over the target five to nine minutes after deploying the spotter chute/WDI. **(T-2).**

**Step 5.** Turn on approach. Make minor changes in heading to pass over the spotter chute/WDI and the target on a direct line. Aircraft drift correction should be established prior to passing over the spotter chute/WDI.

**Step 6.** Initiate a uniform count over the spotter chute/WDI.

**Step 7.** Reverse count over the target.

**Step 8.** Deploy jumpers when the last digit in reverse count is reached.

**Step 9.** After the jumper clears the aircraft, turn to observe the accuracy of the drop. **NOTE:** Deploy additional jumpers using the drop heading and count established in steps 5, 6 and 7. Disregard the spotter chute/WDI for subsequent passes. **NOTE:** When the target drift rate is changed (drogue chute is installed on target, no wind shift occurs, etc.), re-accomplish the entire spotter chute/WDI procedure and establish a new drop heading and count starting with step 1. **(T-3).**

**Note 1:** Deployment procedures to a moving target are similar to those employed for a stationary target. The moving target procedure takes into consideration target drift and will place the team on the down drift line of the moving target and not necessarily on target. **(T-2).**

**Note 2:** Adjust the pattern must be adjusted so the initial pass over the target after spotter chute/WDI deployment is not less than five minutes and not more than nine minutes, with seven minutes being ideal. **(T-3).** If the initial pattern requires more than nine minutes, the team will be too far down drift/downwind and with a high target drift rate may not be able to locate the target visually. **(T-2).**

**Note 3:** On the initial pass after the spotter chute/WDI deployment, an accurate count can be obtained by the JM and the heading noted by both the JM and pilot. All subsequent passes will be made on this initial heading using the count obtained on the first pass. **(T-3).** No attempt should be made to recheck the count or change the initial heading because the target will have drifted. **(T-2).**

**Note 4:** On subsequent passes requiring a change of heading to place the aircraft over the target, ensure the pilot corrects back to original heading. Moving target procedures are normally conducted from fixed-wing aircraft.

**A10.3. GMRS Marking Considerations.**

A10.3.1. DZ markings must be clearly visible to the aircrew on approach as early as possible. **(T-2).** If conditions preclude placing the markings at the computed point, the DZC may have to adjust the location of the intended PI, ensuring compliance with the requirements in **Table 3.1, Table 3.2, Figure 3.1, Figure 3.3, Figure 3.4** and **Figure A10.1** Advise both the aircrew and user of the change in PI location.

A10.3.2. When conducting operations requiring security, night DZ markings should only be visible from the direction of the aircraft's approach. If using flashlights, equip them with simple hoods or shields and aimed toward the approaching aircraft. Screen omni-directional lights, fires, or improvised flares on three sides or place in pits with the sides sloping toward the direction of approach.

A10.3.3. During daylight airdrops, the marker panels may be slanted at a 45-degree angle from the surface toward the aircraft approach path to increase the aircrew's ability to see them, smoke (other than red) may be displayed at the release point or corner marker to assist in aircrew DZ acquisition.

#### A10.4. GMRS: Determining PI Location.

A10.4.1. After selecting the DZ, calculate the dispersion distance, as stated below, then select a PI that is compatible with the calculated point and the tactical situation. Once the PI has been determined, calculate the forward throw distance and wind drift effect to determine the release point.

A10.4.2. Dispersion distance is the total distance within the impact area where troops or cargo will land. **(T-1)**. It is in a direct line with the aircraft's line of flight and is dependent upon aircraft speed and load exit time (the length of time required for the first through the last object to clear the aircraft). The formula for calculating dispersion is:  $\frac{1}{2}S \times E = L$ , where S = aircraft speed in knots, E = exit time in seconds, and L = length of dispersion in yards. This calculation is normally used to assist with placing the PI, rather than determining the release point.

A10.4.3. Wind drift is the lateral movement of a parachute through the air caused by the wind. The distance of the wind drift is measured on a direct line from the parachute's fully deployed opening point to its actual PI on the ground. Calculate this drift using the formula;  $D = KAV$ , where D = drift in meters, K = the load drift constant, A = drop altitude in hundreds of feet (i.e., 1,000 feet = 10) and V = wind velocity in knots. **Table A10.2** depicts the constants for different airdrop loads.

A10.4.4. Forward throw distance is the distance along the aircraft flight path traveled by a parachutist or cargo container after exiting the aircraft, until the parachute fully opens and the load is descending vertically. Refer to **Table A10.3**.

**Table A10.2. Ground Marked Release System Load Drift Constants (K).**

TYPE DROP	K (Load Drift Constant)
Personnel (Static Line)	3.0
Heavy Equipment	1.5
CDS/CRL/CRS	1.5
HVCDS/LCLA/Low Cost Low Velocity	Zero
Door Bundle	1.5
SATB	2.4



**Table A10.3. Ground Marked Release System Forward Throw Distance Data.**

TYPE DROP	C-130	C-17
Personnel (Static Line)/Door Bundle	250 yards (229m)	250 yards (229m)
Personnel (MFF)	328 yards (300m)	328 yards (300m)
Heavy Equipment	500 yards (458m)	700 yards (640m)
CDS/CRS/CRL	550 yards (503m)	725 yards (663m)
SATB	160 yards (147m)	N/A

A10.4.5. Offset is the distance the aircraft will fly to the right of the marker (100 meters) so the markers will remain visible to the aircrew. **(T-2)**.

### **A10.5. GMRS: Marking Placement Techniques.**

A10.5.1. **Step 1.** Stand on the PI facing toward the direction from which the aircraft will approach (reciprocal of DZ axis). **(T-2)**.

A10.5.2. **Step 2.** Pace off the distance calculated for forward travel distance. Record the position coordinates as a GPS markpoint/waypoint.

A10.5.3. **Step 3.** Face directly into the wind. Pace off into the direction of the wind the distance calculated for wind drift. This is the actual release point.

A10.5.4. **Step 4.** Face into the direction from which the aircraft will approach (reciprocal of DZ axis), turn 90 degrees to the right and pace off 100 meters (110 yards) for the offset. **(T-2)**. Place the corner or first panel at this point.

A10.5.5. **Step 5.** Adjust the release point for wind direction/velocity changes by returning to GPS markpoint/waypoint and following steps above.

A10.5.6. **Step 6.** Establish the ground markings as shown in [Figure 3.5](#).

**Attachment 11**  
**SOCOM FORM 111**

**Figure A11.1. SOCOM Form 111 Example.**

<b>1. REQUESTING UNIT</b> <i>Self-explanatory</i>		<b>2. MISSION TYPE OR EXERCISE NAME</b> <i>Self-explanatory</i>		<b>PRIORITY (Entered in block 16)</b>	
<b>3. SUMMARIZED CONCEPT (To Include number and type of aircraft)</b> <i>Describe in detail what is being requested and critical information.</i>  <i>(Samples: LZSO, DZ Survey, CAS, ISR, DZC, LZC, etc., and A/R, purpose, background, discussion, recommendations.)</i>  <i>List any coordinating agencies and POCs for funding.</i>				<b>1. Deployment Training</b> <b>(a) Rehearsal-Pending Ops</b> <b>(b) OIF/OEF Prep</b> (c) CIF Prep  <b>2. JOINT COMBINED TRAINING</b> (a) JCS Exercises (b) Geographic Component Commander Exercise (c) CDRSOCOM directed event (d) SOCOM Component Commander directed event (e) SOATC/19 SOS Joint Training (f) Test Support	
<b>4a. AIRCRAFT (A/C) TYPE</b> (e.g., Helo/Tanker/Gunship – not specific unless req't driven) <i>N/A</i>		<b>4b. PREFERRED // MIN # OF A/C REQUESTED</b> (e.g., Prefer 2 A/C // Min Req'd - 1 A/C) <i>N/A</i>		<b>3. SERVICE &amp; INTEROPERABILITY</b> (a) JRTC (b) NTC (c) USAF Flag Exercise (d) Bilateral Training (e) JCET  <b>4. OTHER</b>	
<b>5a. REQUESTED DATE WINDOW // FLEXIBLE</b> (e.g., 15 Jan – 6 Feb 06, Yes - Flexible within dates) <i>Self-explanatory</i>		<b>5b. PREFERRED // MIN # OF DAYS A/C REQ'D</b> (e.g., Prefer 2 days // Min 1 day Req'd) <i>N/A</i>		<b>6. NUMBER OF PERSONNEL</b>	
<b>7. TYPE OF CARGO:</b> <i>N/A</i>					
<b>8. SPECIAL EQUIPMENT REQUIRED</b> <i>Self-explanatory</i>				<b>9. LOCATION ( /Base/State)</b> (Denote if you are flexible on location ) <i>Self-explanatory</i>	
				<b>10. REQUEST DATE SENT:</b> <i>Self-explanatory</i>	
<b>11. MISSION ITINERARY</b>					
<b>DATE/TIME</b>		<b>ACTIVITY</b>			
<i>Detailed dates and times of any events you're seeking special tactics support for.</i>					
<b>12a. REQUESTING UNIT POC(s) INFO (Name/Tel):</b>			<b>12b. POC(s) UNCLASS E-MAIL ADDRESS (required)</b>		
			<i>Self-explanatory</i>		
<b>13. MISSION STATUS (Dates)</b>		<b>TASKED</b>		<b>PENDING</b>	
<b>DATE STATUS ASSIGNED:</b>					
<b>14. SUPPORTING UNIT NAME</b>					
<b>15. SUPPORTING UNIT POC AND TELEPHONE NUMBER</b>					

<b>16. MISSION PRIORITY NUMBER</b>	<b>17. DATE RECEIVED</b>	<b>18. MISSION NUMBER</b>
<b>SOCOM FORM 111, JAN 06(EF)</b>		