

**BY ORDER OF THE  
SECRETARY OF THE AIR FORCE**

**AIR FORCE MANUAL 11-2MC-130J,  
VOLUME 3**



**3 APRIL 2020**

***Flying Operations***

**MC-130J OPERATIONS PROCEDURES**

**COMPLIANCE WITH THIS PUBLICATION IS MANDATORY**

---

**ACCESSIBILITY:** Publications and forms are available on the e-Publishing website at [www.epublishing.af.mil](http://www.epublishing.af.mil) for downloading or ordering.

**RELEASABILITY:** There are no releasability restrictions on this publication.

---

OPR: AFSOC/A3V

Certified by: AF/A3T  
(Maj Gen James A. Jacobson)

Supersedes: AFI11-2MC-130JV3,  
29 April 2015

Pages: 287

---

This manual implements Air Force Policy Directive (AFPD) 11-2, *Aircrew Operations*, and references Air Force Instruction (AFI) AFI 11-200, *Aircrew Training, Standardization / Evaluation, and General Operations Structure*, AFI 11-202, Vol 3, *General Flight Rules*, and Major Command (MAJCOM) supplements thereto. It applies to all MC-130J units, and it provides the most acceptable guidance and procedures for most circumstances, but does not replace sound judgment. This manual applies to the Active Component, Air National Guard, and the Air Force Reserve (AFR). This publication may be supplemented at any level, but all direct supplements must be routed to the Office of Primary Responsibility (OPR) of this publication for coordination prior to certification and approval. The authorities to waive wing/unit level requirements in this publication are identified with a Tier (“T-0, T-1, T-2, T-3”) number following the compliance statement. See AFI 33-360, *Publications and Forms Management*, for a description of the authorities associated with the Tier numbers. Submit requests for waivers through the chain of command to the appropriate Tier waiver approval authority, or alternately, to the requestor’s commander for non-tiered compliance items. The use of the name or mark of any specific manufacturer, commercial product, commodity or service in this publication does not imply endorsement by the Air Force. Refer recommended changes and questions about this publication to the office of primary responsibility (OPR) using the Air Force (AF) Form 847, *Recommendation for Change of Publication*; route AF Forms 847 from the field through the appropriate functional chain of command. Ensure all records created as a result of processes prescribed in this publication are maintained in accordance with Air Force Manual 33-322, *Records Management and*

*Information Governance Program*, and disposed of in accordance with the Air Force Records Disposition Schedule located in the Air Force Records Information Management System.

## **SUMMARY OF CHANGES**

This document is substantially revised and must be completely reviewed. This change converts AFI 11-2MC-130J, Volume 3 into an AFMAN in response to the Secretary of the Air Force (SAF) and Chief of Staff of the Air Force directed publication review initiative. Significant changes include updating Interim Supplemental Guidance with SAF/AA's new tiered waiver authorities, and aligns MC-130J policies and procedures with numerous other C-130J variants to include the EC-130J, AC-130J and HC-130J. An attachment for Airdrop Operations has been included. Aircrew operating the MC-130J should review this publication in its entirety for substantial changes.

<b>Chapter 1—GENERAL OVERVIEW</b>	<b>13</b>
1.1. Deviations and Waivers. ....	13
1.2. Overview. ....	13
1.3. Applicability. ....	13
1.4. Key Definitions:.....	13
1.5. Distribution. ....	14
1.6. Supplements. ....	14
1.7. Improvement Recommendations. ....	14
<b>Chapter 2—ROLES AND RESPONSIBILITIES</b>	<b>15</b>
2.1. General. ....	15
2.2. MAJCOM & Operational Control (OPCON) Authority. ....	15
2.3. Command Authorities. ....	15
2.4. Operations Center. ....	15
2.5. Wing Commander. ....	15
2.6. Mission Commander. ....	15
2.7. Air Mission Commander (AMC). ....	16
2.8. Deputy Mission Commander (DMC). ....	16
2.9. Pilot in Command. ....	16
2.10. Civilian Law Enforcement Support. ....	16
2.11. Mission Clearance Decision. ....	16

<b>Chapter 3—AIRCREW COMPLEMENT AND MANAGEMENT</b>	<b>18</b>
3.1. Aircrew Qualification. ....	18
3.2. Crew Complement. ....	18
Table 3.1. MC/C-130J Crew Complement. ....	18
3.3. Mission Essential Personnel (MEP). ....	20
3.4. Interfly. ....	20
3.5. Intrafly. ....	21
3.6. Alert Crew Procedures. ....	21
3.7. Flight Duty Period and Crew Rest Restrictions. ....	21
<b>Chapter 4—AIRCRAFT OPERATING GUIDELINES</b>	<b>22</b>
4.1. PIC Responsibilities. ....	22
4.2. Policy. ....	22
4.3. Minimum Equipment List (MEL) Policy. ....	22
4.4. Waiver Protocol. ....	22
4.5. One-Time Flights. ....	22
4.6. Inoperative Fuel Quantity Indicator. ....	22
4.7. Landing Gear System: ....	24
4.8. Soft Panel Operations. ....	24
4.9. MEL Table Definitions/Column Identifiers.....	25
Table 4.1. Air Conditioning and Pressurization.....	25
Table 4.2. Auto Flight.....	29
Table 4.3. Communications.....	32
Table 4.4. Electrical System.....	34
Table 4.5. Equipment.....	35
Table 4.6. Fire Protection.....	35
Table 4.7. Flight Controls.....	36
Table 4.8. Fuel.....	37
Table 4.9. Hydraulic Systems.....	40
Table 4.10. Ice and Rain Protection.....	41

Table 4.11.	Indicating/Recording Systems. ....	42
Table 4.12.	Landing Gear and Brakes.....	43
Table 4.13.	Lights. ....	43
Table 4.14.	Navigation.....	44
Table 4.15.	Oxygen.....	46
Table 4.16.	Pneumatic.....	47
Table 4.17.	System Integration and Display.....	47
Table 4.18.	Auxiliary Power Unit.....	49
Table 4.19.	Doors.....	50
Table 4.20.	Propellers. ....	51
Table 4.21.	Powerplant. ....	51
Table 4.22.	In-Flight Refueling System.....	53
Table 4.23.	Defensive Systems and Situational Awareness Equipment.....	53
<b>Chapter 5—GENERAL OPERATING PROCEDURES</b>		<b>55</b>
5.1.	Aircrew Uniforms. ....	55
5.2.	Personal Requirements and Professional Equipment.....	55
5.3.	Aircrew Publications Requirements. ....	55
Table 5.1.	Aircrew Publications.....	56
5.4.	Aircrew Intelligence Briefing. ....	57
5.5.	Flight Crew Information File. ....	57
5.6.	Aircraft Mission Kits. ....	57
Table 5.2.	Aircraft Mission Kit.....	57
5.7.	Route Navigation Kits. ....	58
Table 5.3.	Route Navigation Kit Contents (Applicable to area of operation).....	58
5.8.	Flight Plan/Data Verification.....	59
5.9.	Communications Security (COMSEC) and Classified Material. ....	59
5.10.	Briefing Requirements. ....	59
5.11.	Call Signs. ....	60
5.12.	Departure/Arrival Planning. ....	60

	5.13.	TOLD Verification Requirement. ....	60
	5.14.	Adverse Weather.....	60
	5.15.	Risk Management (RM). ....	61
	5.16.	AFTO Form 781, Aerospace Vehicle Flight Data Record. ....	61
	5.17.	Forms Management. ....	62
	5.18.	Dash 1 Preflight. ....	62
	5.19.	Alert Aircraft Procedures. ....	63
	5.20.	Aircraft Servicing and Ground Operations. ....	63
	5.21.	Aircrew Flight Equipment and Oxygen Requirements. ....	65
	5.22.	Departure Briefing. ....	67
	5.23.	Traffic Collision Avoidance System/Enhanced Traffic Collision Avoidance System (ETCAS) Operations. ....	67
	5.24.	Communications Policy. ....	67
	5.25.	In-Flight Emergency Procedures. ....	68
Table	5.4.	Conference Hotel for All C-130 Variants.....	68
	5.26.	Need for Medical Assistance. ....	68
	5.27.	Arrival. ....	69
	5.28.	After Beginning an En route Descent. ....	70
	5.29.	Cold Weather Altimeter Setting Procedures. ....	70
	5.30.	Aircraft Recovery Away from Main Operating Base. ....	70
	5.31.	Cockpit Voice Recorder (CVR). ....	71
	5.32.	Clearwater Rinse Facility (Birdbath). ....	71
	5.33.	Support Agencies. ....	71
	5.34.	Crew Debriefing. ....	71
	5.35.	Aircrew Notification Procedures. ....	71
	5.36.	Cockpit Congestion and Loose Objects. ....	71
	5.37.	Dropped Objects. ....	72
	5.38.	Impoundment. ....	72
	5.39.	Narcotics. ....	72

5.40.	Due Regard Procedures. ....	72
5.41.	Sensitive Mission Operations. ....	72
5.42.	Passenger Restrictions. ....	72
5.43.	Cargo Documentation. ....	74
5.44.	Airlifting Hazardous Cargo Material Procedures. ....	75
5.45.	Hazardous Medical Equipment/Special Cargo. ....	77
5.46.	Border Clearance. ....	78
5.47.	Customs Procedures.....	79
5.48.	Immigration Procedures.....	80
5.49.	Customs, Immigration and Agricultural Inspections. ....	80
5.50.	Military Customs Preclearance Inspection Program:.....	81
5.51.	Insect and Pest Control (Aircraft Spraying).....	81
<b>Chapter 6—AIRLAND OPERATIONS</b>		<b>83</b>
6.1.	Aircraft Maximum Gross Weight. ....	83
6.2.	Checklists. ....	83
6.3.	Duty Station. ....	83
6.4.	Flight Deck Entry. ....	83
6.5.	Takeoff and Landing.....	83
6.6.	Landing Gear and Flap Operation.....	84
6.7.	Seat Belts. ....	84
6.8.	Aircraft Lighting. ....	85
6.9.	Advisory/Required Calls. ....	85
Table 6.1.	Takeoff.....	85
Table 6.2.	Climb Out and Descent.....	85
Table 6.3.	Non-Precision Approach.....	85
Table 6.4.	Precision Approach.....	86
6.10.	Wind Limitations. ....	86
6.11.	Runway Condition Reading (RCR) and Runway Surface Condition (RSC). ....	87
Table 6.5.	RCR Values. ....	87

	6.12.	Wake Turbulence Avoidance. ....	87
	6.13.	Landing Zone (LZ) Markings. ....	87
	6.14.	Aircraft Rescue Fire-Fighting Requirements (ARFF). ....	87
	6.15.	Crew Resource Management (CRM). ....	87
	6.16.	Automation. ....	88
Table	6.6.	Automated Flight. ....	89
Table	6.7.	Manual Flight. ....	90
	6.17.	Ground Collision Avoidance System (GCAS)/Terrain Awareness and Warning System (TAWS). ....	90
	6.18.	Radar Altimeter. ....	91
	6.19.	Runway and Taxiway Requirements. ....	91
Table	6.8.	Normal Operations and Maximum Effort Operations. ....	92
	6.20.	Aircraft Taxi Obstruction Clearance Criteria. ....	94
Figure	6.1.	Ground Operations Obstruction Clearance Criteria. ....	95
	6.21.	Reverse Taxi. ....	95
	6.22.	Takeoff and Landing Obstruction Clearance Criteria. ....	95
Figure	6.2.	Takeoff and Landing Obstruction Clearance Criteria. ....	96
	6.23.	Three-Engine Takeoffs. ....	96
	6.24.	Aircraft Recovery from Unprepared Surfaces. ....	96
	6.25.	Engines Running Onload or Offload (ERO). ....	96
	6.26.	Stabilized Approach Philosophy. ....	97
<b>Chapter 7—AIRCRAFT SECURITY</b>			<b>99</b>
	7.1.	General. ....	99
<b>Chapter 8—OPERATIONAL REPORTS AND FORMS</b>			<b>100</b>
	8.1.	General. ....	100
	8.2.	AF Form 457, USAF Hazard Report. ....	100
	8.3.	AF Form 651, Hazardous Air Traffic Report. ....	100
	8.4.	AF Form 711B, USAF Mishap Report . ....	101
	8.5.	Reports of Violations/Unusual Events or Circumstances. ....	102

8.6.	Petroleum, Oil, and Lubricants (POL) - Aviation Fuels Documentation. ....	103
8.7.	AF Form 15, United States Air Force Invoice. ....	105
8.8.	AF Form 853, Bird Strike Report. ....	106
8.9.	DD Form 1748-2, Airdrop Malfunction Report (Personnel-Cargo). ....	106
<b>Chapter 9—FLYING TRAINING POLICY</b>		<b>107</b>
9.1.	General. ....	107
9.2.	Instructor/Flight Examiner Briefings. ....	107
9.3.	Debriefing. ....	107
9.4.	Simulated Emergency Flight Procedures (EPs). ....	107
9.5.	Maneuver Restrictions. ....	107
9.6.	Touch-and-Go Landings. ....	108
9.7.	Stop-and-Go Landings. ....	109
9.8.	Prohibited Maneuvers. ....	109
9.9.	Landing Restrictions with Airdrop Loads. ....	109
9.10.	Simulated Instrument Flight. ....	110
9.11.	Air-to-Air Refueling Training Restrictions. ....	110
<b>Chapter 10—LOCAL OPERATING PROCEDURES</b>		<b>111</b>
10.1.	General. ....	111
<b>Chapter 11—NAVIGATION PROCEDURES</b>		<b>112</b>
11.1.	General. ....	112
11.2.	Special Certification Airspace Requirements and Procedures. ....	113
11.3.	Mission Planning Procedures. ....	114
11.4.	Preflight Procedures. ....	117
11.5.	CAT I In-Flight Navigation Procedures. ....	118
11.6.	Navigation Malfunctions and Failures. ....	122
<b>Chapter 12—FUEL PLANNING</b>		<b>124</b>
12.1.	General. ....	124
12.2.	Alternate Selection. ....	124
12.3.	Fuel Planning Profiles. ....	124



12.4.	Fuel Planning Procedures. ....	125
Table 12.1.	MC-130J Fuel Load Requirements. ....	127
Figure 12.1.	Master Flight Plan with Example Annotations (not for flight). ....	128
12.5.	Air to Air Refueling Fuel Planning Procedures. ....	129
Figure 12.2.	AF FORM 4139J .....	131
<b>Chapter 13—LOADMASTER PROCEDURES</b>		<b>133</b>
13.1.	General. ....	133
13.2.	Aircraft Loading Responsibilities. ....	133
13.3.	Emergency Exits and Safety Aisles. ....	133
13.4.	Flight Monitoring. ....	133
13.5.	Weight and Balance. ....	134
13.6.	Air Cargo Restraint Criteria. ....	134
13.7.	Mission Equipment Requirements. ....	134
13.8.	Channel Cargo and Passenger Missions. ....	135
13.9.	Passenger Handling.....	135
13.10.	Troop Movements. ....	135
13.11.	Border Clearance. ....	136
13.12.	Hostile Environment Operations. ....	136
13.13.	Rapid Infiltration/Exfiltration (“Rapids”). ....	136
13.14.	Combat Offload. ....	136
13.15.	FARP. ....	136
<b>Chapter 14—ELECTRONIC WARFARE PROCEDURES</b>		<b>137</b>
14.1.	General. ....	137
14.2.	In-Flight Responsibilities.....	137
<b>Chapter 15—COMMUNICATIONS</b>		<b>139</b>
15.1.	General. ....	139
<b>Chapter 16—DIRECT SUPPORT OPERATOR PROCEDURES</b>		<b>140</b>
16.1.	General. ....	140
16.2.	Mission Planning Factors.....	140

	16.3.	Preflight/In-Flight Responsibilities. ....	140
	16.4.	Communications Procedures. ....	140
	16.5.	Post Mission. ....	140
	16.6.	Augmentation. ....	141
	<b>Chapter 17—</b>	<b>TACTICAL EMPLOYMENT PROCEDURES</b>	<b>142</b>
	17.1.	General. ....	142
	17.2.	Crew Duties. ....	142
	17.3.	Survival and Protective Equipment. ....	142
	17.4.	Equipment Requirements. ....	142
Table	17.1.	Tactical Operations. ....	143
	17.5.	Mission Planning. ....	143
Figure	17.1.	Inherent Chart Error. ....	145
	17.6.	Preparation for NVG Operations. ....	146
	17.7.	Low-Level Operations. ....	146
Figure	17.2.	Minimum Safe Altitude. ....	147
	17.8.	Low-Level Emergency Procedures. ....	149
Table	17.2.	Emergency Climb Procedure. ....	149
	17.9.	Radar Altimeter Usage. ....	150
	17.10.	Defensive Maneuvers and Equipment. ....	150
	17.11.	Degraded Systems Training (DST). ....	151
	17.12.	Self-Contained Approach (SCA). ....	151
	17.13.	SCA Template Construction. ....	152
Figure	17.3.	SCA Horizontal Obstruction Clearance Template. ....	153
Figure	17.4.	Turning SCA Horizontal Obs Clearance Template (Not to Scale) (1 of 2). ....	154
Figure	17.5.	Turning SCA Horizontal Obs Clearance Template (Not to Scale) (2 of 2). ....	155
Figure	17.6.	Critical Obstacle Chart. ....	157
Figure	17.7.	SCA Vertical Template. ....	158
	17.14.	SCA Execution. ....	158
	17.15.	SCA Crew Actions. ....	159

	17.16. Airdrop Operations. ....	161
Figure	17.8. Prusik Knot. ....	170
Table	17.3. Center Stick Targeting Minimum DZ Size. ....	174
	17.17. Formation Procedures. ....	176
Table	17.4. Lighting Chart. ....	180
	17.18. Tanker Air-to-Air Refueling. ....	181
	17.19. Receiver Air-to-Air Refueling. ....	181
<b>Chapter 18—LEAFLET AIRDROP</b>		<b>183</b>
	18.1. General. ....	183
	18.2. Mission Description. ....	183
	18.3. Equipment. ....	183
	18.4. Aircraft Configuration. ....	183
	18.5. Preparation for Loading. ....	184
	18.6. Securing Boxes. ....	185
	18.7. Connecting Static Lines. ....	185
	18.8. Restraint Strapping. ....	185
Figure	18.1. Leaflet Box Rigging Procedures. ....	186
	18.9. Leaflet Box Rigging Procedures. ....	186
	18.10. Preparation for Airdrop. ....	187
	18.11. Aircrew Procedures. ....	187
	18.12. Static Lines. ....	187
<b>Chapter 19—SEARCH AND RESCUE PROCEDURES</b>		<b>188</b>
	19.1. General. ....	188
Table	19.1. Search and Rescue Frequencies. ....	188
Table	19.2. Distress and Emergency Frequencies. ....	188
	19.2. Search Altitude. ....	189
Figure	19.1. Lost Airplane Fixing Procedures. ....	190
Table	19.3. Sweep Width for Visual Search in Nautical Miles. ....	190
Table	19.4. Whitecap Correction Factors. ....	190

Table	19.5.	Cloud Cover Factor.....	191
Table	19.6.	Expected Detection Range for Visual Aids (30 Miles Visibility).....	191
Table	19.7.	Recommended Search Altitudes.....	191
	19.3.	Search Procedures.....	192
Table	19.8.	Sector Search Pattern Computation.....	195
Table	19.9.	Wind and Sea Prediction Chart.....	195
	19.4.	Departing Search Area.....	197
	19.5.	Rescue Airdrops.....	197
Figure	19.2.	Standard Sea Rescue Kit Pattern.....	198
	19.6.	Sea Rescue Kits: .....	201
Figure	19.3.	Rigging Sequence.....	203
Figure	19.4.	Sea Rescue Kit, Light Rigging.....	204
	19.7.	Pyrotechnics:.....	204
Figure	19.5.	Rescue Lanyard.....	209
<b>Attachment 1—GLOSSARY OF REFERENCES AND SUPPORTING INFORMATION</b>			<b>210</b>
<b>Attachment 2—INFILTRATION/EXFILTRATION PROCEDURES</b>			<b>232</b>
<b>Attachment 3—HOT REFUELING/FARP PROCEDURES</b>			<b>239</b>
<b>Attachment 4—COMBAT OFFLOAD PROCEDURES</b>			<b>249</b>
<b>Attachment 5—BRIEFING GUIDE</b>			<b>256</b>
<b>Attachment 6—AIRDROP OPERATIONS</b>			<b>275</b>
<b>Attachment 7—Figure A7.1. Communication, Navigation and Surveillance/ Air Traffic Management (CNS/ATM) Systems and Procedures.</b>			<b>287</b>

## Chapter 1

### GENERAL OVERVIEW

**1.1. Deviations and Waivers.** Do not deviate from the policies and guidance in this manual except when the situation demands immediate action to ensure safety. The OPR grants waivers only in accordance with (IAW) this manual. (T-1)

1.1.1. Tier requirements refer to waiver authority based on level of risk:

1.1.1.1. “Tier 0” (T-0) requirements are reserved for requirements that non-compliance is determined and waived by respective non-Air Force authority.

1.1.1.2. “Tier 1” (T-1) requirements are reserved for requirements that non-compliance may put airman, mission, or program strongly at risk, and may only be waived by the Major Command Commander (MAJCOM/CC) or delegate with concurrence of publication approver. When multiple MAJCOMs are affected, then T-1 is appropriate.

1.1.1.3. “Tier 2” (T-2) requirements are reserved for requirements that potentially put the mission at risk or potentially degrade the mission or program, and may only be waived by the MAJCOM/CC or delegate.

1.1.1.4. “Tier 3” (T-3) requirements are reserved for requirements that non-compliance has a remote risk of mission failure, and may be waived by the Wing (WG) Commander but no lower than the Squadron (SQ) Commander.

1.1.2. Although this publication provides guidance for aircraft operations under most circumstances, it is not a substitute for sound judgment. When it is necessary to protect the crew and aircraft from a situation not covered by this manual and when immediate action is required, the Pilot In Command (PIC) has ultimate authority and responsibility for the course of action to be taken. Report deviations, without waiver, through channels to MAJCOM/A3 within 48 hours, followed by a written report, if requested. Unless otherwise indicated, MAJCOM/A3 (with coordination through MAJCOM Standardization and Evaluations (MAJCOM/A3V)) is the waiver authority for operational procedure requirements contained in this volume. Request waivers through Standardization/Evaluation (Stan/Eval) channels. (T-2)

**1.2. Overview.** This Air Force Manual (AFMAN) provides operational guidelines and restrictions for MC-130J aircraft. This manual is regulatory in nature and takes precedence over guidance in Air Force Tactics, Techniques and Procedures (AFTTP).

**1.3. Applicability.** This manual is applicable to all individuals and units operating MC-130J aircraft and units operating Special Operations Forces (SOF) C-130J variant airlift or tanker aircraft.

**1.4. Key Definitions:**

1.4.1. “Will,” “Shall” and “Must” language indicates a mandatory requirement, and punitive in nature.

1.4.2. “Should” indicates a preferred, but not mandatory, method of accomplishment.

1.4.3. “May” indicates an acceptable or suggested means of accomplishment.

1.4.4. “**WARNING**” indicates operating procedures, techniques, etc., which may result in personal injury or loss of life if not carefully followed.

1.4.5. “**CAUTION**” indicates operating procedures, techniques, etc., which may result in damage to equipment if not carefully followed.

1.4.6. “**Note**” indicates operating procedures, techniques, etc., which are considered essential to emphasize.

1.4.7. See [Attachment 1](#) Glossary of References and Supporting Information, for additional terms.

**1.5. Distribution. All MC-130J aircrew members will maintain a full copy of this manual. (T-2)**

**1.6. Supplements. Major Commands (MAJCOM) may supplement this volume according to AFI 11-200. MAJCOM supplements will not duplicate or be less restrictive than the provisions of this manual. Forward MAJCOM supplements to AFSOC/A3V for coordination and Air Force Flight Standards Agency Flight Directives division (AFFSA/XOF) for approval before publication and provide AFFSA/XOF one copy after publication. Squadrons shall define local operating procedures to this manual in a unit supplement in accordance with (IAW) [Chapter 10](#). (T-2)**

**1.7. Improvement Recommendations. Send comments and suggested improvements to this manual on AF Form 847, *Recommendation for Change of Publication*.**

## Chapter 2

### ROLES AND RESPONSIBILITIES

**2.1. General.** MAJCOMs will publish specific Command and Control (C2) system guidance in the “Roles and Responsibilities” section of any MAJCOM supplements to this manual.

**2.2. MAJCOM & Operational Control (OPCON) Authority.** MAJCOMs will publish applicable OPCON authorities in any MAJCOM supplements to this manual.

**2.3. Command Authorities.** MAJCOMs will publish specific command authorities in any MAJCOM supplements to this manual.

**2.4. Operations Center.** MAJCOMs will publish specific operations center processes and requirements in any MAJCOM supplements to this manual.

**2.5. Wing Commander.** Wing commanders or equivalent hold waiver/approval authority for items normally authorized at or below wing level. This includes the following items:

2.5.1. Deployments.

2.5.2. Air Apportionment Allocation Conference taskings.

2.5.3. Joint Air Apportionment Allocation Conference taskings.

2.5.4. Joint Combined Exchange Training (JCET)/Counter Narcotics Training missions.

2.5.5. Other specified missions as tasked via the SOF Air Tasking Order (ATO).

2.5.6. Contiguous United States (CONUS) and Outside Contiguous United States (OCONUS) forces departing a Theater Special Operations Command (TSOC)/Joint Special Operations Air Component (JSOAC) Area of Responsibility (AOR) en route to United States Northern Command (NORTHCOM) AOR.

2.5.7. Air Reserve Component (ARC) forces (under Title 10).

2.5.8. Depart home station for MAJCOM-directed contingencies/deployments/exercises (under Title 10).

2.5.9. Wing commander OPCON terminates when forces enter a TSOC/JSOAC AOR and picks up when forces exit a TSOC/JSOAC AOR.

**2.6. Mission Commander.** A mission commander will be designated when more than one aircraft or crew is deployed away from home station for training, exercises or other operations. (T-3) The mission commander will be rated, and should be a field grade officer. (T-3) The mission or air mission commander will not be a primary crew member for exercises, but may fly as a crew member on non-exercise related missions. (T-3) Mission commanders are responsible for overall mission execution as well as aircraft and personnel supporting the mission. Duties include but are not limited to:

2.6.1. Briefing crews on local operating procedures.

2.6.2. Coordinating with Air Traffic Control (ATC), Combat Control Team, Special Tactics Squadron (STS), range control, users and others that may have an impact on the mission.

2.6.3. Ensuring personnel have ample and adequate billeting, eating and transportation arrangements.

2.6.4. Ensuring maintenance personnel know of aircraft and fuel requirements.

2.6.5. Submitting timely reports on aircraft movements.

**2.7. Air Mission Commander (AMC).** The individual responsible for the overall employment of all air assets assigned to the mission. Required for multi-element, multi-event formations, and/or where mission complexity dictates. The AMC will not be a primary crew member and should be on headset. **(T-3)**

**2.8. Deputy Mission Commander (DMC).** Required on all missions employing a dedicated AMC, on all multi-element formation missions, and on all single-element formations of three aircraft or more. (T-3) The DMC assumes command if conditions prevent the AMC from controlling the mission. The DMC may be a primary crew member, and is usually the Formation Commander on AMC controlled missions. The DMC will not be on the same aircraft as the AMC. (T-3) On missions not employing a dedicated AMC, the DMC is chosen from the PICs, and Combat Systems Operators (CSO) involved in the formation. **(T-3)**

**2.9. Pilot in Command.** The Pilot in Command (PIC) is officially designated on the AF Form 4327A, *Crew Flight (FA) Authorization*, for all flights. (T-2) PICs are:

2.9.1. In command of all persons on board the aircraft.

2.9.2. Responsible for the welfare of their aircrew members, mission essential personnel and the safe accomplishment of the mission.

2.9.3. Vested with the authority necessary to manage their crew and safely accomplish the mission.

2.9.4. The final mission authority and will make decisions not specifically assigned to a higher authority.

2.9.5. The final authority for accepting a waiver affecting the crew or mission.

2.9.6. Charged with keeping the applicable commander informed of mission progress and difficulties.

2.9.7. For required maintenance support when away from home station, PICs will coordinate with AFSOC/A4 Combat Logistics Operations (CLO). CLO may be contacted at: DSN 579-8925/8935, commercial 850-884-8925 or email [afsoca4.a4modclo@us.af.mil](mailto:afsoca4.a4modclo@us.af.mil).

**2.10. Civilian Law Enforcement Support.** It is AF and DoD policy to cooperate with civilian law enforcement officials to the maximum extent practicable. AFI 10-801, *Defense Support of Civil Authorities*, incorporates the appropriate directive and provides uniform policies and procedures service members must follow when supporting federal, state, and local civilian law enforcement agencies. It establishes specific limitations and restrictions on the use of AF personnel, equipment, facilities and services by civilian law enforcement organizations. Report all requests for assistance and coordinate all requests from civilian law enforcement authorities through the appropriate command and control channels. **(T-3)**

**2.11. Mission Clearance Decision.** The final decision to delay a mission may be made either by the agency with OPCON or the PIC when, in the opinion of either, conditions are not safe to start



or continue a mission. Final responsibility for the safe conduct of the mission rests with the PIC. If the PIC refuses a mission, it will not depart until the conditions have been corrected or improved so that the mission can operate safely. The controlling authority will not alert another PIC and aircrew to take the same mission under the same conditions. (T-3)

2.11.1. Diverting or rerouting a mission must be authorized by the commander with OPCON, except in an emergency or when required by en route or terminal weather conditions or facilities. (T-3) In the event of an emergency or weather related divert or reroute, the mission commander PIC must notify the controlling authority as soon as possible. (T-3)

2.11.1.1. The controlling agency directing the diversion or rerouting is responsible for ensuring destination requirements or facilities are adequate for the aircraft and aircrew.

2.11.1.2. The PIC will notify the controlling agency of any aircraft or aircrew limitations that may preclude diverting or rerouting the mission. (T-3)

2.11.2. When directing an aircraft to an alternate airfield, the controlling agency will ensure the PIC is provided existing and forecasted weather for the alternate. (T-3) If the planned alternate is unsuitable upon arrival at destination, the controlling agency will advise the PIC of other suitable alternates. (T-3)

## Chapter 3

### AIRCREW COMPLEMENT AND MANAGEMENT

**3.1. Aircrew Qualification.** Each person assigned as a primary crew member must be qualified or in training for qualification in that crew position, mission and Mission Design Series (MDS) aircraft. (T-2)

3.1.1. Basic aircraft qualified crew members may perform primary crew duties on any non-mission sortie and on mission sorties (including unilateral training, joint training, and exercises) when receiving mission qualification training or evaluations under the supervision of a qualified instructor or flight examiner in their respective crew position.

3.1.2. Basic Mission Capable (BMC) crew members may perform primary crew duties on any unilateral training mission. For other missions, the unit commander must determine the readiness of each mission capable crew member to perform primary duties.

3.1.3. Noncurrent (NC) or Unqualified (UNQ) pilots may perform crew duties only on designated training or evaluation missions under the supervision of a qualified instructor or flight examiner pilot. Comply with the requirements for pilots in dual controlled aircraft in AFI 11-401, *Aviation Management*.

3.1.4. Other NC or UNQ crew members may perform duties in their primary crew position on any mission when under the direct supervision of a qualified instructor or flight examiner in their respective crew position or as outlined in AFMAN 11-2MC-130J, Vol 1, *MC-130J Aircrew Training*. Except as noted in **Table 3.1** the student crew member and the instructor or flight examiner fulfill the requirement for one primary position.

3.1.5. Unqualified personnel may perform familiarization training in non-pilot crew positions during flight when under direct instructor supervision. AFI 11-401 and MAJCOM Supplements contain information on orientation flight requirements.

**3.2. Crew Complement.** Crew complement is specified in **Table 3.1**. Unit commanders may authorize reduced crew complements as noted in the table. The waiver authority for any additional crew complement reductions, down to the minimum crew complement specified in the aircraft flight manual, is the group commander or Commander Air Force Special Operations Forces (COMAFSOF). This authority may be delegated no lower than squadron commander. With the exception of the Combat Mission Profile, all events accomplished with a reduced crew complement can be logged as long as the applicable event criteria in AFMAN 11-2MC-130J, Vol 1, are met.

**Table 3.1. MC/C-130J Crew Complement.**

Crew Position	Non-mission Sorties <sup>7</sup>		Mission Sorties	
	Basic Crew	Augmented Crew	Basic Crew	Augmented Crew
Aircraft Commander (AC)	1	2 <sup>1</sup>	1	2 <sup>1</sup>
Pilot	1	1	1	1
CSO	0 <sup>1</sup>	0	1 <sup>2</sup>	2

Loadmaster (LM)	1 <sup>3</sup>	2	2 <sup>3,4,5,6</sup>	3
<p>Notes:</p> <ol style="list-style-type: none"> <li>1. Both ACs must be qualified in all phases of the mission to be accomplished. Transfer of PIC duties between qualified ACs will be briefed to the crew.</li> <li>2. A CSO is not required during Air-to-Air Refueling (AAR) or Night Vision Goggle (NVG) max effort takeoff and landings.</li> <li>3. Two loadmasters: <ol style="list-style-type: none"> <li>a) If more than 40 passengers are scheduled to be carried (except during unit moves or contingencies). Both crew members must remain in the cargo compartment, one forward and one aft for takeoffs and landings. <b>Exception:</b> One Loadmaster and another qualified crew member are required.</li> <li>b) The following Ramp and door airdrops: Static Line (S/L) Personnel, Rigged Alternate Method Zodiac (RAMZ), Container Ramp Load (CRL) if accompanied by personnel, Combat Rubber Raiding Craft (CRRC), Heavy Equipment (HE) both towplate and non-towplate, and Extracted Container Delivery System High Speed and Low Speed (XCDS-HS/LS).</li> <li>c) Airdrops when both paratroop doors are open.</li> <li>d) Free fall personnel airdrops above 13,000 feet Mean Sea Level (MSL).</li> <li>e) Simultaneous Helicopter Air-to-Air Refueling (HAAR).</li> <li>f) Forward Area Refueling Point (FARP) tanker operations.</li> </ol> </li> <li>4. Instructor Loadmaster (IL) and two students are considered full mission complement on training sorties, except during HAAR/Tiltrotor Air-to-Air Refueling (TAAR) when accomplishing simultaneous refueling.</li> <li>5. At Sq/CC discretion, an IL and student fulfills the two LM requirement to drop unilateral training heavy equipment loads without Emergency Parachute Jettison System (EPJS).</li> <li>6. Only one LM is required for tactical training missions if any of the situations below apply: <ol style="list-style-type: none"> <li>a) Personnel or door bundle (less than 100 lbs) drops using only one paratroop door. <b>Exception:</b> Bundles in excess of 100 lbs require an additional pusher and those between 350-500 lbs require two additional pushers</li> <li>b) High-altitude (up to 13,000 feet MSL) non-static line personnel are dropped from the ramp and door, or only one paratroop door is opened.</li> <li>c) Container Delivery System (CDS) airdrops, including Tri-Wall Aerial Delivery System (TRIADS).</li> <li>d) Dropping only Standard Airdrop Training Bundles (SATBs).</li> <li>e) Unilateral heavy equipment training loads utilizing the EPJS.</li> <li>f) HAAR/TAAR, single hose operations.</li> <li>g) Formation sorties.</li> </ol> </li> </ol>				

- h) Low Cost Low-Altitude (LCLA) airdrops, without in-flight drifting.
  - i) FARP receiver.
7. Non-Mission Sorties are defined as a sortie that does not include any tactical events such as low levels, airdrops, infil/exfil, HAAR/TAAR, and contingency operations.

**3.3. Mission Essential Personnel (MEP). See AFI 11-401.**

**3.4. Interfly.** Interfly is the exchange and/or substitution of aircrew members and/or aircraft between MAJCOMs to accomplish flying missions. Normally, interfly should be used to share operational experience opportunities between units and to relieve qualified manpower shortfalls.

3.4.1. MAJCOM/A4 maintains current Memorandum of Agreements (MOAs) between AFSOC, AFRC, National Guard Bureau (NGB), Air Force Materiel Command (AFMC), Air Education Training Command (AETC) and Air Combat Command (ACC) for interfly using assigned aircraft. Unless specified in the MOA:

3.4.1.1. Aircraft ownership will not be transferred. (T-2)

3.4.1.2. The operational squadron will prepare and sign the flight authorizations. (T-3)

3.4.1.3. As a minimum, crew member(s) will be Basic Aircraft Qualified (BAQ) in the MDS-aircraft and model, as well as systems or configuration required to fly the aircraft and/or mission. (T-2)

3.4.1.4. Aircrew will follow operational procedures defined in this manual, AFTTP 3-1.E/MC-130J *Tactical Employment E/MC-130J*, AFTTP 3-3.E/MC-130J *Combat Aircraft Fundamentals*, and the applicable Technical Orders (TO) for the MDS. MC-130J aircrews flying C-130J aircraft will follow AFMAN 11-2MC-130J, Vol 1, AFMAN 11-2MC-130J, Vol 2, *MC-130J Aircrew Evaluation Criteria* and the applicable Technical Orders for the MDS. (T-2)

3.4.1.5. Flight and ground mishap reporting responsibility will be handled IAW AFI 91-204, *Safety Investigations and Reports*. (T-2)

3.4.2. Waiver Authority.

3.4.2.1. With a valid MOA. Group commander or COMAFSOF is the approval authority for interfly on MC-130J aircraft under their control.

3.4.2.2. IAW AFI 11-401 ANG SUP, the Operations Group/CC is the approval authority on all ANG aircraft under Title 32 control. **Note:** IAW **Paragraph 2.2**, OPCON is established with MAJCOMS absent other guidance.

3.4.2.3. No MOA/Expired MOA. MAJCOM/A3 is the approval authority for interfly on MC-130J aircraft.

3.4.2.4. Contingency operations must be approved by both respective MAJCOM/A3s. (T-1)

3.4.3. Aircrew members assigned to the USAF Weapons School (USAFWS) are authorized to participate in orientation flights in MC-130J aircraft operated by crews from 14th Weapons Squadron (WPS).

3.4.4. Aircrew members assigned to the USAFWS are authorized to occupy duty positions on MC-130J aircraft operated by 14 WPS. Crew members must be under instructor supervision if not current and qualified in the MDS. (T-2)

3.4.4.1. The above authorizations are extended to senior leadership in the USAFWS chain of command.

3.4.4.2. Flights conducted under the above provisions will be within the normal syllabi. (T-2)

**3.5. Intrafly.** Intrafly is the exchange and/or substitution of aircrew members from separate units under the same MAJCOM to accomplish flying missions. Normally, intrafly should be used to share operational and training experience opportunities between units and to relieve qualified manpower shortfalls.

3.5.1. Intrafly between units is authorized, units will provide notification to the Group Commander possessing the aircraft or COMAFSOF when conducting intrafly.

3.5.2. IAW AFI 11-401 ANG SUP, the Operations Group/CC is the authority for ANG aircraft under Title 32 control. **Note:** IAW **Paragraph 2.2**, absent contrary guidance, MAJCOM is granted OPCON over assigned SOF aircraft.

3.5.3. As a minimum, crew member(s) will be qualified in the MDS-aircraft and model, as well as systems or configuration required to fly the aircraft and/or mission. (T-2)

3.5.4. Aircrew will follow operational procedures defined in AFMAN 11-2MC-130J, Vol 3, AFTTP 3-1.E/MC-130J and 3-3.E/MC-130/J, and the applicable TO for the MDS. MC-130J aircrews flying C-130J aircraft will follow AFMAN 11-2MC-130J, Vol 1, AFMAN 11-2MC-130J, Vol 2, and the applicable TO for the MDS. (T-2)

**3.6. Alert Crew Procedures.** See AFI 11-202, Vol 3, and MAJCOM Supplement.

**3.7. Flight Duty Period and Crew Rest Restrictions.** See AFI 11-202, Vol 3, and MAJCOM Supplement.

## Chapter 4

### AIRCRAFT OPERATING GUIDELINES

**4.1. PIC Responsibilities.** The final responsibility regarding equipment required for a mission rests with the PIC. When the PIC considers an item essential, designate the component Mission Essential or “ME” on the Air Force Technical Order (AFTO) Form 781A, *Maintenance Discrepancy and Work Document*, and the item will be repaired or replaced prior to departure.

**4.2. Policy.** This chapter provides guidance on how to operate with degraded equipment. If the PIC elects to operate with degraded equipment or aircraft system(s), coordinate mission requirements (i.e., revised departure times, fuel requirements, maintenance requirements, etc.), prior to flight with the mission control agency to ensure the decision does not adversely impact follow-on missions.

**4.3. Minimum Equipment List (MEL) Policy.** The MEL is a prelaunch document that lists the minimum equipment/systems to operate the aircraft prior to takeoff. It is impractical to prepare a list that would anticipate all possible combinations of equipment malfunctions and contingent circumstances. Consider equipment/systems with no listed exceptions as grounding items. A PIC who accepted an aircraft with degraded equipment/systems is not committed to subsequent operations with the same degraded equipment. PICs are not committed to operations with degraded equipment accepted by another PIC.

4.3.1. The PIC shall account for the possibility of additional failures during continued operation with inoperative systems or components. The MEL is not intended for continued operation over an indefinite period with systems/subsystems inoperative.

4.3.2. All emergency equipment will be installed and operational unless specifically exempted by mission requirements/directives. (T-2)

4.3.3. PICs operating with waiver(s) for degraded equipment shall coordinate mission requirements (revised departure times, fuel requirements and maintenance requirements). Report deviations (without waiver) to Operations Group (OG)/CC within 48 hours, if requested. (T-3)

**4.4. Waiver Protocol.** Waivers to operate with degraded equipment are granted on a case-by-case basis. Refer to [Paragraph 1.1](#) for waiver authorities.

**4.5. One-Time Flights.** Refer to TO 00-20-1, *Aerospace Equipment Maintenance Inspection, Documentation, Policies, and Procedures*, for downgrade authority and procedures. One-time flight approval authority is OG/CC or COMAFSOF. The owning Maintenance Group (MXG)/CC (or designated official), the senior maintenance officer, or the on-site chief of an AFMC repair team must first authorize the release. PIC concurrence is required before the aircraft can be flown. (T-2)

**4.6. Inoperative Fuel Quantity Indicator.** The primary concern with inoperative fuel boost pumps or quantity indicators is fuel balance and wing loading. Degraded operation is permissible; however, flight crews must consider potentially trapped fuel and decreased range should further degradation occur. This paragraph and the MEL provides guidelines for degraded fuel system operations under most circumstances. Note: Although the fuel quantity indications can be displayed on multiple Heads Down Display (HDD) System Status Displays as well as on the hard

panels, repetitions in excess of one indication per tank are not relevant. The 'number installed' includes one indication per tank and the 'number required' specifies the number of tanks that must have an operative indication.

4.6.1. In-flight, fuel will not be transferred into or out of a main fuel tank with an inoperative indicator or its symmetrical tank except for the following:

4.6.1.1. Fuel transfer into a main tank with an inoperative indicator may be accomplished during contingency or emergency fuel need situations. All transfers, under these conditions, require more than one crew member to monitor and coordinate the fuel transfer.

4.6.1.2. A reliable source of known quantity transferred must be available. This source can be either the internal aircraft operating fuel quantity indicators or in-flight refueling tanker fuel onload data.

4.6.1.3. Begin cross-feed operation when the symmetrically opposite quantity indicator has decreased to 1,500 pounds (inboards) and 2,500 pounds (outboards).

4.6.1.4. Engine out training using the engine corresponding to the inoperative indicator or its symmetrically opposite will not be conducted during tank to engine operation.(T-3)

4.6.1.5. Maintain symmetrical engine fuel flow.

4.6.1.6. Plan to land with a minimum of 4,000 pounds calculated main tank fuel.

4.6.2. When an external tank indicator is inoperative and the tank cannot be visually checked empty due to foam modification, comply with the following prior to flight:

4.6.2.1. Check pressure with each pump in the external tank. If no pressure is obtained, the tank is verified empty.

4.6.2.2. If pressure is obtained, ground transfer the fuel from the external tank. Defuel the external tank if unable to ground transfer.

4.6.2.3. When unable to verify an external tank is empty prior to engine start, place the tank on cross-feed until no pressure is obtained. This will be completed prior to takeoff.

4.6.3. Maintain symmetrical tanks within 1,000 pounds at all times. If small amounts (4,000 pounds or less) must be transferred, then transfer up to 1,000 pounds into the tank with the inoperative indicator followed by an equal amount into the tank(s) with operative indicator(s). If large amounts of fuel must be transferred, then transfer 1,000 pounds into the tank with the inoperative indicator, then up to 2,000 pounds as needed into the tank(s) with the operative indicators, then up to 1,000 pounds as needed into the tank with the inoperative indicator to bring all tanks symmetrical, or continue up to 2,000 pounds as needed, repeating the cycle until desired fuel quantity and balance is achieved in applicable tanks. (T-3)

4.6.4. During tanker AAR, fuel may be transferred from main or external tanks with inoperative fuel quantity indicators only if the receiver requires emergency fuel. In this situation, the following procedures will apply:

4.6.4.1. The fuel flow counter for the refueling pod being used must be operational to track the amount of fuel transferred. (T-3)

4.6.4.2. Transfer from only one tank at a time.

4.6.4.3. Transfer no more than 1,000 pounds at a time between the tanks with the inoperative indicator and its symmetrical tank to monitor fuel balance.

**4.7. Landing Gear System:** If a landing gear system or position indicator malfunction is encountered, only a full stop landing will be made. The discrepancy will be corrected prior to the next flight. Exception: If repair capability does not exist and a positive determination is made that further flight can be accomplished with the gear down and locked, the aircraft may be flown to a destination where repair capability exists provided the gear is not moved from the down and locked position. Required en route stops are authorized.

#### **4.8. Soft Panel Operations.**

4.8.1. For partial or complete hard panel failures, aircrews may revert to soft panel operations. Normally, if a soft panel is selected due to hard panel failure, it should be used for the remainder of the flight. Doing so will mitigate the hazards associated with restoring hard panel functionality for an item when the mission computer commanded-state is unknown. Accomplishing the ENGINE SHUTDOWN and BEFORE LEAVING AIRPLANE checklists after the aircraft is parked will ensure the soft panel retains control of the particular item throughout shutdown. In all cases, PICs must consider the increased workload associated with using soft panels.

4.8.2. Hard panel failures may be the result of a physical failure or loss of communication with the Mission Computer (MC), an aircraft reboot may recover hard panel functionality. To determine if hard panel functionality can be regained, the following procedures must be followed in sequential order:

4.8.2.1. Completely power down when accomplishing the BEFORE LEAVING AIRPLANE checklist.

4.8.2.2. Complete all checklist items in the POWER UP checklist. Do not proceed past the POWER UP checklist until it can be determined if the hard panel has recovered. Depending on the system effected (such as Auxiliary Power Unit (APU), bleed air, landing gear, etc.), do not apply bleed air or hydraulics until hard panel functionality can be determined.

4.8.2.3. To determine if a hard panel has recovered, ensure hard panel and soft panel selections/settings are identical. Press the Line Select Key (LSK) to turn the soft panel OFF. If a Communication/Navigation/Identification (CNI) "Check (CHK) HARD PNL" or a referenced hard panel fault Advisory Caution and Warning System (ACAWS) message (i.e., "APU PNL FAULT", "DEF SYS PNL FAULT", etc.), does not appear, press the "VERIFY OFF" LSK. If feasible, check hard panel functionality.

4.8.2.4. If a CNI "CHK HARD PNL" or a referenced hard panel fault ACAWS message appears, the hard panel has not recovered. The "CHK HARD PNL" message indicates there is a mismatch between the soft panel and hard panel commands to the MC independent of physical switch positions. Referenced hard panel fault messages are self-explanatory.

4.8.2.5. If it is determined that the hard panel has not recovered, at the PIC discretion, the mission may continue to a station supporting a repair capability, including en route stops.



Do not reselect the hard panel. If a flight must continue under the control of two or more soft panels, a COMAFSOF waiver is required.

4.8.3. After returning to home station or repair facility with a hard panel malfunction, aircrews will shut down and turn the aircraft over to maintenance personnel for required actions. (T-3)

**4.9. MEL Table Definitions/Column Identifiers.**

4.9.1. Installed – Number of components or systems installed.

4.9.1.1. In some cases, a component can be controlled from either a hard panel or from a soft panel. Similarly, some indications can be viewed on either a hard panel or a soft panel. Since switch functions (or indications) may be duplicated on each of the three Communication/Navigation/Identification Management Unit (CNI-MU) displays, the number of switches (or indications) installed may not always be clear. To clarify this condition, switches (or indications) are listed as ‘1’ in the installed column even when they are duplicated on a soft panel.

4.9.1.2. Although the indications on each pilot’s (HDD) can be repeated on more than one HDD, repetitions of data in excess of one per pilot are not relevant for flight and are not counted in this MEL. In general, the flight deck is designed to provide one set of data for the pilot and one set of data for the copilot (in addition to the standby instruments). Thus, for most HDD indications, the number installed is listed as ‘2’, one for each pilot.

4.9.2. Required – The minimum number (quantity) of items required for operation provided the conditions specified in the remarks or exception column are met. Unless otherwise noted, when the item is a switch (or indication) which is duplicated on a soft panel, the number required for dispatch may be satisfied by either the hard panel switch (or indication) or by the switch (indication) on one of the associated soft panels. For HDD indications, the number required is ‘2’ if both pilots must have an indication, ‘1’ if only one pilot must have an indication and ‘0’ if neither pilot is required to have the indication. For essential flight data (heading, altitude, airspeed, attitude and when required, navigation data), the pilot’s and copilot’s displays must have independent sources. (T-2)

4.9.3. Remarks and Exceptions. Some technical information and procedures are contained in this column. This is not all-inclusive; crew members shall refer to the flight manual and other directives for procedures, techniques, limitations, etc.

**Table 4.1. Air Conditioning and Pressurization.**

System Item	Installed	Required	Remarks or Exceptions
Air-Conditioning System	2	1	One may be inoperative provided: (1) Cross-flow valve is operative, (2) Associated Flow Control Valve is CLOSED, (3) Consideration is given to the type mission, fuel quantity, required cruise altitude and oxygen quantity.

	2	0	<p>Both may be inoperative provided:</p> <p>(1) Both Flow Control Valves are verified CLOSED,</p> <p>(2) Aircraft is operated unpressurized,</p> <p>(3) Auxiliary Vent Valves are operative for ventilation and</p> <p>(4) Consideration is given to required cruise altitude, fuel quantity, OAT and oxygen quantity.</p> <p style="text-align: center;"><b>NOTE:</b></p> <p>Pressurization and both air conditioning systems may be needed if passengers or patients are carried. If a system fails, flight to a destination with repair capability (including en route stops) may be accomplished (coordinate with the MCD when patients are carried). Passengers and patients will be briefed on the possibility that discomfort may be</p>
<b>System Item</b>	<b>Installed</b>	<b>Required</b>	<b>Remarks or Exceptions</b>
<b>Air-Conditioning Control Panel</b>	1	0	May be inoperative provided control is available through the associated soft panel.
a. Automatic Temperature Control System	2	0	<p>May be inoperative provided:</p> <p>Respective Manual Temperature Control System is operative,</p> <p style="text-align: center;"><b>OR</b></p> <p>(1) Respective Air-conditioning System is considered inoperative, and</p> <p>(2) Temperature control is not required.</p>
b. BA/ECS Channels	2	1	<p style="text-align: center;"><b>NOTE</b></p> <p>Loss of the 2<sup>nd</sup> Channel will result in loss of all pneumatic-powered components and systems (except engine anti-ice).</p>
c. Cargo Compartment Recirculation Fan	1	0	See Flight Manual for cooling restrictions.
d. Cross-Flow Valve	1	0	<p>May be inoperative provided both air-conditioning systems are serviceable</p> <p style="text-align: center;"><b>OR</b></p> <p>Only one air-conditioning system is operative and the valve is manually positioned to Cargo Compartment 100% open.</p>

e. Flow Control and Shut-Off Valve			
(1) Cargo Compartment Air-Conditioning System	1	0	May be inoperative provided: (1) Divider Valve operative, (2) Right Wing Isolation Valve operative and (3) ECS Cross-flow Valve is operative.
(2) Flight Station Air- Conditioning System	1	0	May be inoperative provided: (1) Divider Valve operative, (2) Left Wing Isolation Valve is operative and (3) ECS Cross-Flow Valve is operative.
f. Temperature Control Valve	2	0	May be inoperative provided: Valve is failed in the normal temperature range  <b>OR</b> Air-Conditioning System is considered inoperative.
g. Duct Overheat Temperature Sensor	2	0	May be inoperative provided associated Air- Conditioning System is considered inoperative.
<b>System Item</b>	<b>Installed</b>	<b>Required</b>	<b>Remarks or Exceptions</b>
<b>Auxiliary Vent Valve, Flight Deck</b>	1	1	
<b>Auxiliary Vent Valve, Cargo Compartment</b>	1	0	
<b>Avionics Cooling System</b>			
a. Avionics Cooling Fans	2	1	
b. Cargo Compartment Avionics Cooling Fans	2	1	
c. Overhead Console Cooling Fans	2	1	If both fail in-flight, damage to Heads Up Displays (HUDs) may occur. Use Primary Flight Displays (PFDs) as required. If HUDs are stowed, pull the associated ECBs to prevent damage from heat.
<b>Cargo Under Floor Heat System</b>	1	0	May be inoperative provided consideration is given to Outside Air Temperature (OAT) and the number of passengers/additional crew members on board.
<b>Pressurization System</b>			
a. Automatic Pressure	1	1	One channel may be inoperative.

Control System	1	0	May be completely inoperative provided: (1) Manual Pressurization System is operative and (2) Consideration is given to the additional crew workload caused by using Manual Pressurization <b>OR</b> (1) Aircraft is operated unpressurized, and (2) Consideration is given to required cruise altitude, fuel/oxygen quantity and OAT.
(1) CONST Altitude (ALT) Mode	1	0	May be inoperative provided consideration is given to the type mission to be flown.
b. Emergency Depressurization Handle	1	0	May be inoperative provided: (1) Aircraft is operated unpressurized (2) Consideration should be given to required cruise altitude, fuel/oxygen quantity, and OAT <b>NOTE:</b> N/A If mission essential equipment is installed in the center escape hatch.
<b>System Item</b>	<b>Installed</b>	<b>Required</b>	<b>Remarks or Exceptions</b>
c. Emergency Depressurization Switch	1	0	May be inoperative provided: (1) Control is available through the associated soft panel, <b>OR</b> (1) Aircraft is operated unpressurized. (2) Consideration should be given to required cruise altitude, fuel/oxygen quantity and OAT.
<b>d. Manual Pressurization Control System</b>	1	0	May be inoperative provided: (1) Automatic Pressurization System is operative <b>OR</b> (1) Aircraft is operated unpressurized, (2) Consideration should be given to required cruise altitude, fuel/oxygen quantity and OAT.

<b>e. Outflow Valve</b>	1	0	May be inoperative provided: (1) Valve is manually positioned to full open (2) Pressurization Mode Select Switch is positioned to NO PRESS, (3) Aircraft is operated unpressurized, (4) Consideration should be given to required cruise altitude, fuel/oxygen quantity and OAT.
<b>f. Safety Valve</b>	1	0	May be inoperative provided: (1) Outflow Valve is manually positioned to full open (2) Aircraft is operated unpressurized, (3) Consideration should be given to required cruise altitude, fuel/oxygen quantity, and OAT.

**Table 4.2. Auto Flight.**

<b>System Item</b>	<b>Installe</b>	<b>Required</b>	<b>Remarks or Exceptions</b>
<b>Auto/Throttle (A/T) System</b>	2	0	
<b>Digital Autopilot System</b>	2	0	May be inoperative provided: (1) Associated autopilot is not essential for performance of mission requirements. (2) If both autopilots are inoperative, give consideration to reduced crew duty day.
<b>Digital Autopilot/Flight Director (DA/FD) Controls</b>			<b>NOTE:</b> An automatic altitude control system capable of maintaining altitude within 65 feet of that assigned is required for operation in Reduced Vertical Separation Minimums (RVSM) airspace.
<b>a. Autopilot Disengage Switch (Control Wheel)</b>	2	0	Both may be inoperative provided another method of disengaging the autopilot is operative (e.g., G/A Switch).  <b>NOTE:</b> Failure of either Autopilot Disengage switch will disengage any autopilot function that is engaged at that time and will prevent either autopilot from reengaging until the switch function is repaired. Deselecting flight director modes on the REF/MODE panel does not disengage the autopilot. The one exception is deselecting APPR after glideslope capture. This will disengage the autopilot.

<b>b. Autopilot Engage Lever</b>	2	0	May be inoperative provided associated autopilot is considered inoperative.
<b>c. Course Knob</b>	2	0	May be inoperative provided: (1) Associated DA/FD Navigation (NAV) and Approach (APPR) Modes (except INAV) are considered inoperative (2) Associated Course Arrow and indication is considered inoperative (except in INAV Mode) (3) Departure/route/approach to destination (and alternate, if applicable) does not require use of VOR/ILS/MB or TACAN.
<b>d. Go-Around (G/A) Switch</b>	2	0	Consider Go-Around Implications
<b>System Item</b>	<b>Installe</b>	<b>Required</b>	<b>Remarks or Exceptions</b>
<b>e. Heading Knob</b>	2	0	May be inoperative provided: (1) Associated DA/FD Heading Mode is considered inoperative. (2) Associated Heading Marker is considered inoperative.
<b>f. Lateral Axis (LAT) OFF Switch</b>	1	0	May be inoperative provided the Autopilot Lateral Mode is considered inoperative.
<b>g. Pitch Axis (PITCH) OFF Switch</b>	1	0	May be inoperative provided the Autopilot Pitch Mode is considered inoperative.  <p style="text-align: center;"><b>NOTE:</b></p> An automatic altitude control system is required for operation in RVSM airspace.
<b>h. Pitch Control Wheel</b>	1	0	May be inoperative provided: (1) Autopilot Pitch Attitude Hold Mode is operative <p style="text-align: center;"><b>OR</b></p> (1) Autopilot Pitch Mode is considered inoperative, and (2) Autopilot Pitch OFF Switch is positioned to OFF.
<b>i. Pitch Synchronization (SYN) Switch</b>	2	0	

<b>j. Reference Mode (REF/MODE) Panel</b>	2	1	One time flight authorized to repair facility, including en route stops.
<b>(1) ALT SEL Switch</b>	2	0	May be inoperative provided: (1) Associated Altitude Alert System is considered inoperative, (2) Associated DA/FD Altitude Select Mode is considered inoperative, and (3) Ground Collision Avoidance System (GCAS) is serviceable.  <b>NOTE:</b> An altitude alerting system is required for operation in RVSM.
<b>(2) BARO SET Switch</b>	2	1	<b>NOTE:</b> Both Baro Set switches must be operational for operation in RVSM.
<b>System Item</b>	<b>Installed</b>	<b>Required</b>	<b>Remarks or Exceptions</b>
<b>(3) Mode Select Switch</b>	18	0	Individual Mode Select Switch(es) may be inoperative provided associated mode(s) are considered inoperative.  <b>NOTE:</b> For a given mode to be inoperative, both the pilot and copilot switches for that mode would have to be inoperative.  <b>NOTE:</b> An automatic altitude control system is required for operation in RVSM airspace.
<b>(4) Reference Select Switch</b>	2	1	
<b>(5) Reference Set Knob</b>	2	1	
<b>k. Turn Ring</b>	1	0	May be inoperative provided: Autopilot Roll Attitude Hold Mode is operative  <b>OR</b> Autopilot Lateral Mode is considered Inoperative and, Autopilot LAT OFF Switch is switched Off.
<b>Digital Autopilot/Flight Director (DA/FD) Indications</b>			

a. Automatic Flight Control System (AFCS) Annunciator Panel	2	0	May be inoperative provided inoperative annunciation(s) is operative on the HUD or HDD PFD at affected location.
b. Reference Set Panel Display	2	0	May be inoperative provided: Individual Reference Annunciations and Markers (e.g., HUD, PFD cards, lines on tapes, carets) are operative  <b>OR</b> Associated Reference Annunciations and Markers (e.g., HUD, PFD cards, lines on tapes, carets) are considered inoperative.
<b>Flight Director System</b>	2	0	May be inoperative provided Flight Director is not required for mission accomplishment or approach.

Table 4.3. Communications.

System Item	Installed	Required	Remarks or Exceptions
<b>Control Wheel Hush Switch</b>	2	1	
<b>Control Wheel Microphone Switch</b>	2	0	If both control wheel microphone switches are inoperative, both P/CP center pedestal rocker switches must be operative.
<b>Flight Station Speaker</b>	2	1	
<b>Get Home Radio Panel</b>	1	0	One time flight is authorized to a repair facility.
<b>Identification Friend or Foe (IFF) System</b>	1	1	Aircraft will not depart with an IFF/Selective Identification Feature (SIF) known to be inoperative.  <b>NOTE:</b> An altitude reporting transponder is required for operation in RVSM airspace.



	1	0	<p>Aircraft may fly in formation with inoperable IFF provided at least one operational IFF exists per element.</p> <p style="text-align: center;"><b>OR</b></p> <p>Aircraft may takeoff with the permission of ATC and the PIC if the IFF was operational on the previous mission provided the following:</p> <ol style="list-style-type: none"> <li>(1) Previous mission was completed same day.</li> <li>(2) The crew performs a ground check of the IFF/SIF before takeoff, using either the self-test, ground radar interrogator or ground test equipment.</li> <li>(3) If the self-test fails, accomplish an airborne check after takeoff.</li> </ol> <p style="text-align: center;"><b>NOTE:</b></p> <p>Mode IV is not required for flights that originate in and will remain inside the inner boundaries of all domestic &amp; coastal ADIZ's surrounding the CONUS.</p>
a. Antenna	2	1	Mode 4 and Mode S require both antennas.
<b>Public Address (PA) System</b>	1	0	May be inoperative if passengers or troops are carried and, at the discretion of the crew, effective and safe communications can be conducted.
<b>Ultra High Frequency (UHF)/Very High Frequency (VHF) Radios</b>	4	2	<p>May be inoperative unless essential for performance of mission, route, and Air Traffic Control requirements.</p> <p style="text-align: center;"><b>NOTE:</b></p> <p>UHF No. 1 or VHF No. 1 must be operative.</p>
<b>System Item</b>	<b>Installed</b>	<b>Required</b>	<b>Remarks or Exceptions</b>
<b>HF Radios</b>	2	0	1 required for long range communications. Consider mission impact.
<b>ARC 210 Radio</b>	1	0	Consider mission impact.
<b>Digital Intercommunication System (ICS)</b>			
a. Headset Interface Unit (HIU)	8	3	As required provided each crewmember has an operable HIU.
b. ICS Monitor Panels	4	2	As required.

Table 4.4. Electrical System.

System Item	Installed	Required	Remarks or Exceptions
<b>AC Generator, Engine</b>	4	3	May be inoperative if repair capability is not available. Flight to a destination with repair capability, including en route stops, may be made. The generator will be removed and the generator mount padded before flight.
<b>Batteries</b>	2	2	
<b>DC Voltmeter</b>	1	1	
<b>Electrical Control Panel</b>	1	0	May be inoperative provided control is available through the associated soft panel.
<b>Electronic Circuit Breaker Unit</b>	14	14	
<b>Indications (System Status Display)</b>			
a. Load Meter Indications	5	5	
b. Voltmeter Indication, AC	5	5	
c. Voltmeter Indication, DC	2	2	
<b>Inverters</b>			
a. Essential Avionics AC Bus	1	1	
b. Essential Avionics AC 26V Power	1	1	
c. Main Avionics AC Bus	1	1	
d. Main Avionics AC 26V Power	1	1	
<b>Regulated Power Supply (RPS) System</b>	8	0	May be inoperative provided the equipment normally powered through the inoperative Regulated Power Supply System is not required,  <b>OR</b> Control is available through the associated soft panel.
<b>Transformer Rectifiers (TR)</b>	4	3	One TR may be inoperative for flight to a repair facility including en route stops. Excludes TR#5 (LAIRCM).

<b>Special Systems Power Distribution Panel</b>	1	0	Consider mission impact.
---	---	---	--------------------------

Table 4.5. Equipment.

<b>System Item</b>	<b>Installed</b>	<b>Required</b>	<b>Remarks or Exceptions</b>
<b>Aerial Delivery System</b>			
a. Aerial Delivery Control Panel	1	0	May be inoperative provided: Control is available through associated Soft Panel,  <b>OR</b> Airdrop operations will not be conducted.
<b>Multifunction Control Display (MFCD)</b>	1	0	May be inoperative provided Heavy Equipment airdrop or combat offload operations will not be conducted.  <b>Exception:</b> May be inoperative for Heavy Equipment airdrop or combat offload during contingency operations if operational needs outweigh the risk of operating without the MFCD.
<b>Pallet Lock Control Unit (PLCU)</b>	7	0	Heavy Equipment airdrop or combat offload operations will not be conducted if the associated PLCU is inoperative. The MFCD must be operational.
<b>Winch</b>	1	0	Consider mission impact.

Table 4.6. Fire Protection.

<b>System Item</b>	<b>Installed</b>	<b>Required</b>	<b>Remarks or Exceptions</b>
<b>APU Fire Control Handle Lights</b>	1	1	
<b>APU Fire Detection Loop</b>	2	1	Flight to a station with repair capability, including en route stops is authorized.
	2	0	The APU is considered inoperative.
<b>Bleed Air Overheat Detection Sensors</b>	14	7	One sensor in each zone may be inoperative for flight to a station with repair capability, including en route stops.
<b>Engine/APU Fire Extinguisher Bottle</b>	2	2	
<b>Engine Fire Control Handle Lights</b>	4	4	
<b>Engine Fire Detection</b>	2	2	

<b>Loop (per nacelle)</b>	2	1	Flight is authorized in the following cases: (1) Flight to a station with repair capability including en route stops, or (2) OG/CC or COMAFSOF may authorize additional training or mission flights. When utilizing this authorization, the aircraft will remain within 250 NM of a repair facility.
<b>Fire and Overheat Detector System (FODS) Controller</b>	2	1	One time flight authorized to repair facility, including en route stops is authorized.
<b>Smoke Detector</b>	4	1	The under flight deck detector must be operational.

Table 4.7. Flight Controls.

<b>System Item</b>	<b>Installed</b>	<b>Required</b>	<b>Remarks or Exceptions</b>
<b>Aileron Trim Indicator</b>	1	0	Flight to a destination with repair capability, including en route stops, may be made. The trim tab position must be visually verified prior to flight.
<b>Aileron Trim System</b>	1	1	
<b>Elevator Trim Indicator</b>	1	0	Flight to a destination with repair capability, including en route stops, may be made. The trim tab position must be visually verified prior to flight.
<b>Elevator Trim System</b>	1	1	
<b>Elevator Trim Tab Control Wheel Switch</b>	4	4	
<b>Elevator Trim Tab Power Selector Switch</b>	1	1	
<b>Emergency Elevator Trim Tab Switch</b>	1	1	
<b>Flap Position Indicator (AMU)</b>	1	0	Flight to a destination with repair capability, including en route stops, may be made provided flap position can be verified via the cargo compartment flap position indicator.
<b>Flap Position Indicator Gauge</b>	1	0	May be inoperative provided Flap Position Indicator (AMU) is operative.
<b>Rudder System Direct Reading Pressure Gauge</b>	2	0	

<b>Rudder Trim Indicator</b>	1	0	Flight to a destination with repair capability, including en route stops, may be made. The trim tab position must be visually verified prior to flight.
<b>Rudder Trim System</b>	1	1	
<b>Stick Pusher System</b>	1	0	Flight to a destination with repair capability, including en route stops, may be made provided the Stall Warning System is operational.
<b>Stall Warning System</b>	1	1	All stall warning system aural and visual warnings must be functional.
a. Angle of Attack Sensor	2	1	

**Table 4.8. Fuel.**

<b>System Item</b>	<b>Installed</b>	<b>Required</b>	<b>Remarks or Exceptions</b>
<b>Auxiliary and External Tank Empty Pressure Switch</b>	2	0	Both may be inoperative provided the quantity gauges are serviceable.
<b>Auxiliary Tank Magnetic Sight Gauge</b>	2	0	Both may be inoperative provided Magnetic Sight Gauge is not required to determine Auxiliary Tank fuel quantity.
<b>Boost Pump, Main Tank</b>	4	3	One may be inoperative provided: <ul style="list-style-type: none"> <li>(1) Applicable Flight Manual Limitations and Procedures are observed,</li> <li>(2) Main Tank Transfer Pumps are operative and,</li> <li>(3) ECBs for inoperative Main Tank Boost Pump are strapped opened.</li> </ul>
<b>Cross-Ship Manifold Fuel Pressure Indication</b>	1	0	May be inoperative provided indication is available through the associated soft panel.
<b>Cross-Feed Valve</b>	4	0	May be inoperative provided: <ul style="list-style-type: none"> <li>(1) Associated Fuel Level Control Valve is operative,</li> <li>(2) Affected Valve is secured CLOSED,</li> <li>(3) Main Tank Transfer Pumps are operative.</li> <li>(4) Cross-ship Separation Valve is operative and</li> <li>(5) Consider mission impact</li> </ul> <p style="text-align: center;"><b>NOTE:</b></p> Valve must be manually closed if failed open or ECBs opened if valve is failed closed.

<b>Cross-ship Separation Valve</b>	3	2	Two required for in-flight refueling missions.
	3	0	May be inoperative provided valve(s) is/are electrically disconnected and secured OPEN.
<b>Fuel Control Panel</b>	1	0	May be inoperative provided control is available through the associated Soft Panel.
<b>Fuel Dump Valve</b>	2	1	May be inoperative provided the valve is secured CLOSED and at least 2 cross-ship valves are operative.
<b>Fuel Management Controller</b>	1	1	One channel may be inoperative.
<b>Fuel Firewall Shutoff Valve</b>	4	4	
<b>System Item</b>	<b>Installed</b>	<b>Required</b>	<b>Remarks or Exceptions</b>
<b>Fuel Level Control Valve (FLCV)</b>			<b>NOTE:</b> Mission fuel requirements must be considered before accepting inoperative
a. Fuel Level Control Valve, Auxiliary Tank	2	0	Both may be inoperative provided valve is not required for ground or in-flight air-to-air refueling.
b. Fuel Level Control Valve, Main Tank	6	0	All may be inoperative provided: (1) Valve is not required for ground or in-flight refueling. (2) All Main Tank Transfer Pumps are operative. (3) All Main Tank Cross-feed Valves are operative. (4) Cross-ship Separation Valves are operative.  <b>NOTE:</b> In the outboard tanks, if an inboard Fuel Level Control Valve is failed closed, the associated tank cannot be fully fueled on the ground and if an outboard Fuel Level Control Valve is failed closed, the associated tank cannot be fully refueled in-flight.
c. Fuel Level Control Valve, External Tank	2	0	Both may be inoperative provided valve is not required for ground or in-flight air-to-air refueling.
<b>Fuel Pressure Relief Valve</b>	2	2	
<b>Fuel Pressure</b>	1	0	

Transducer			
System Item	Installed	Required	Remarks or Exceptions
<b>Fuel Quantity Indications</b> <b>See Paragraph 4.6 for detailed guidance and procedures.</b>			<b>NOTE:</b> Although the fuel quantity indications can be displayed on multiple HDD System Status Displays as well as on the hard panels, repetitions in excess of one indication per tank are not relevant. The ‘number installed’ includes one indication per tank and the ‘number required’ specifies the number of tanks that must have an operative indication.
a. Auxiliary Tank	2	1	One may be inoperative provided: (1) All Fuel Flow Indicators are operative, (2) Associated Fuel Transfer Pump is operative, (3) All other Fuel Quantity Indicators for tanks with fuel on the same side of the Cross-ship Valve are operative and (4) Fuel quantity in the associated tank is verified by an accepted procedure.
	2	0	Two may be inoperative provided associated Fuel Tanks are verified EMPTY.
b. External Tank (if installed)	2	1	One may be inoperative provided: (1) All Fuel Flow Indicators are operative, (2) At least one associated Fuel Transfer Pump is operative, (3) All other Fuel Quantity Indicators for tanks with fuel on the same side of the Cross-ship Valve are operative and (4) Fuel quantity in the associated tank is verified by an accepted procedure
	2	0	Two may be inoperative provided associated Fuel Tanks are verified EMPTY.

c. Main Tank	4	3	One may be inoperative provided: (1) All Fuel Flow Indicators are operative, (2) Associated Fuel Boost Pump is operative, (3) All other Fuel Quantity Indicators for tanks with fuel on the same side of the Cross-ship Valve are operative and (4) Fuel quantity in the associated tank is verified by an accepted procedure
d. Totalizer	1	0	
<b>Fuel Quantity Preset Switch</b>	2	0	
<b>System Item</b>	<b>Installed</b>	<b>Required</b>	<b>Remarks or Exceptions</b>
<b>Single Point Refueling Drain Valve</b>	1	0	May be inoperative provided the manifold is manually drained by maintenance and in-flight refueling will not occur.
<b>Single Point Refuel Valve</b>	1	0	May be inoperative provided alternate refueling procedures can be used. In-flight refueling is allowed for fuel emergencies and contingency operations.
<b>Transfer Pump</b>			
a. Transfer Pump, Auxiliary Tank (1 Each)	2	0	May be inoperative provided ECBs for inoperative pump are open. If pump is inoperative, associated tank is considered unusable.
b. Transfer Pump, External Tank (2 Each)	4	2	One pump in each tank may be inoperative provided ECBs for inoperative External Tank Transfer Pump are opened.
	4	0	Both pumps in each tank may be inoperative provided: (1) ECBs for inoperative pumps are open and (2) Both tanks are empty.
c. Transfer Pump, Main Tank (1 Each)	4	0	May be inoperative provided ECBs for inoperative transfer pump are open and the respective Main Tank Boost Pump is operative. Consider mission impacts on refueling

**Table 4.9. Hydraulic Systems.**

<b>System Item</b>	<b>Installed</b>	<b>Required</b>	<b>Remarks or Exceptions</b>
--------------------	------------------	-----------------	------------------------------



<b>Hydraulic Control Panel</b>	1	0	May be inoperative provided control is available through the associated Soft Panel.
<b>Hydraulic Pumps</b>			
a. Auxiliary Hydraulic Pump	1	1	
b. Engine Hydraulic Pump	4	4	
c. Hand Pump, Auxiliary	1	0	May be inoperative provided no air-to-air refueling is required
d. Suction Boost Pump	2	2	
<b>Hydraulic System Indications (System Status Display)</b>			
a. Auxiliary System Pressure	1	0	May be inoperative provided the direct reading gauge is serviceable.
b. Booster System Pressure	1	0	May be inoperative provided Rudder Boost Pressure Indication is operative.
c. Utility System Pressure	1	0	May be inoperative provided Rudder Boost Pressure Indication is operative.

**Table 4.10. Ice and Rain Protection.**

<b>System Item</b>	<b>Installed</b>	<b>Required</b>	<b>Remarks or Exceptions</b>
<b>Angle of Attack Sensor Anti-ice System</b>	2	1	May be inoperative provided Angle of Attack sensor is considered inoperative.

<b>Ice Detector</b>	2	0	Both may be inoperative provided: Wing Leading Edge Lights are operative  <b>OR</b> Aircraft is not operated in known or forecast icing conditions.
<b>Ice Protection Control Panel</b>	1	0	May be inoperative provided control is available through the associated soft panel.
<b>Engine Anti-Ice Valve</b>	4	0	Valve may be inoperative provided the failed valve has failed OPEN. If failed CLOSED do not operate in known or forecast icing conditions. If failed OPEN consider engine performance adjustments on TOLD.
<b>NESA Windshield Heat System</b>	2	0	May be inoperative provided the aircraft is not operated in known or forecast icing conditions. Flight manual restrictions apply.
<b>Pitot Heat System</b>	2	1	May be inoperative provided associated pitot static system is considered inoperative.
<b>Propeller Ice Protection System</b>	4	0	May be inoperative provided aircraft is not operated in known or forecast icing conditions.
<b>Propeller De-icing Timer Unit</b>	1	0	May be inoperative provided aircraft is not operated in known or forecast icing conditions.
<b>Total Air Temperature Sensor Anti-Ice System</b>	2	0	May be inoperative provided aircraft is not operated in known or forecast icing conditions.
<b>Windshield Defog</b>	2	0	
<b>Windshield Wiper</b>	2	0	
<b>Wing and Empennage Ice Protection System</b>	1	0	May be inoperative provided aircraft is not operated in known or forecast icing conditions.

**Table 4.11. Indicating/Recording Systems.**

<b>System Item</b>	<b>Installed</b>	<b>Required</b>	<b>Remarks or Exceptions</b>
<b>Advisory Caution and Warning System</b>	1	1	

<b>Cockpit Voice Recorder (CVR)</b>	1	1	All components must be operative for the CVR to be considered operative.  <b>EXCEPTION:</b> Underwater Acoustic Locator Beacon (on CVR) may be inop provided flight profile does not include over water segments.
<b>Digital Flight Data Recorder (DFDR)</b>	1	1	All components must be operative for the DFDR to be considered operative.  <b>EXCEPTION:</b> Underwater Acoustic Locator Beacon (on DFDR) may be inop provided flight profile does not include over water segments.

Table 4.12. Landing Gear and Brakes.

System Item	Installed	Required	Remarks or Exceptions
<b>Antiskid System</b>	1	0	May be inoperative provided: Antiskid System ECBs are opened, and Flight Manual Performance limitations are applied, and Shall be repaired at first capable repair facility.
<b>Brake Pressure Indication</b>			
a. Emergency Brake Pressure	1	0	May be inoperative provided the Auxiliary System Pressure direct reading gauge is operative.
b. Normal Brake Pressure	1	0	May be inoperative provided Utility System Pressure Indication is operative.
<b>Landing Gear Lever Lock</b>	1	0	May be inoperative provided Landing Gear Control Panel is considered inoperative.  <b>NOTE:</b> On associated Soft Panel the Lock Function is satisfied by the Verify Switch.
<b>Landing Gear Position</b>	3	3	
<b>Landing Gear Handle Warning</b>	2	0	May be inoperative provided GCAS is operational.

Table 4.13. Lights.

System Item	Installed	Required	Remarks or Exceptions
<b>Exterior Lighting</b>			

a. Landing Light	2	1	Visible lights: One landing light may be inoperative provided taxi light on that side is operative.
	2	0	Infrared (IR) lights: May be inoperative if not required for mission execution.
b. Landing Light Motor	2	0	If extended, observe appropriate airspeed limitations, and Landing Light(s) is considered inoperative unless fully extended.
c. Navigation Light	6	3	For night operations, the left and right wingtip Nav lights must be operational in addition to one of the white lights on the tail cone.
d. Anti-Collision (Strobe) Light	2	0	May continue to first stop where repairs can be made.
e. Taxi Light	2	0	Both may be inoperative provided landing lights are operative.
f. Wing Leading Edge Lights	2	0	May be inoperative at night provided: Ice Detectors are operative,  <b>OR</b> Aircraft is not operated in known/forecast icing.
g. Wing Tip Taxi Lights	2	0	May be inoperative provided aircraft is not taxied in congested areas at night without adequate lighting for obstacle clearance.
<b>Flight Station Lighting</b>			May be inoperative provided sufficient lighting is operative to make each instrument, control and other device for which it is provided easily readable.
a. Copilot Displays Light Circuit	1	1	
b. Lamp Test Circuit	1	1	

Table 4.14. Navigation.

System Item	Installed	Required	Remarks or Exceptions
ADC	2	1	Both must be operative for operation in RVSM airspace.

<b>Automatic Direction Finding (ADF) System</b>	2	0	Both may be inoperative provided departure/ route/approach to destination (and alternate, if applicable) does not require use of ADF.  <b>NOTE:</b> All components must be operative for an ADF to be considered operative.
<b>Cursor System</b>	2	0	May be inoperative unless required to accomplish mission objectives.
<b>Digital Mapping System</b>	1	0	
<b>Terrain Awareness and Warning System (TAWS)</b>	1	0	May be inop unless required to accomplish mission objectives. Consideration should be given to the terrain, required altitudes, route peculiarities, visibility, the crew's experience with the route and whether the mission is conducted during daylight hours or at night.
<b>Embedded Global Positioning/Inertial Navigation System (EGI)</b>	2	1	May be inoperative provided: (1) Overwater (out of Navigation Aid (NAVAID) range) or Basic Area Navigation (BRNAV) flight will not be conducted, (2) Consult FLIP for airspace restrictions.
<b>Global Positioning System (GPS)</b>	2	0	With GPS inoperative, the In-Flight Alignment capability will not be available.
<b>Ground Collision Avoidance System</b>	1	0	May be inoperative provided passengers/troops will not be carried. Consideration should be given to tactical operations and crew experience.
<b>Inertial Navigation Unit</b>	2	2	Both must be functional to meet requirement of redundant heading, altitude and airspeed information for Civil Airspace compliance.
<b>Radar, Low Power Color</b>	1	0	Required if thunderstorms or hazardous conditions that can be detected by airborne radar are forecast or exist along route of flight. Consider operational mission impacts.
a. Control Panel	2	0	May be inoperative provided: (1) Control is available through the associated Soft Panel, (2) Modes other than the Map or Weather (WX) Modes are not essential to accomplish mission objectives and (3) Consider operational mission impacts.
<b>System Item</b>	<b>Installed</b>	<b>Required</b>	<b>Remarks or Exceptions</b>

<b>Radar Altimeter (RADALT)</b>	2	1	One may be inoperative provided Category (CAT) II ILS approaches will not be flown. See Tactical Employment chapter for additional tactical restrictions.
<b>Standby Flight Instruments</b>			
a. Inclinometer (Slip ball)	2	0	May be inoperative provided HUD Slip/Skid Indicator at affected position is operative.
b. Magnetic Compass	1	1	
c. Standby Airspeed/Altimeter	1	1	
d. Standby Attitude	1	1	
<b>Tactical Air Navigation</b>	2	0	All components must be operative for the TACAN to be considered operative. If both TACANs are inoperative, Distance Measuring Equipment (DME) is not available.
<b>Total Air Temperature</b>	2	2	
<b>Traffic Alert Collision Avoidance System (TCAS)</b>	1	0	May be inoperative provided: TCAS is deactivated and secured, and TCAS is not necessary for compliance with ATC requirements.
<b>UHF Direction Finder System</b>	1	0	May be inoperative unless essential for performance of mission objectives.
<b>VHF Navigation System (VOR/ILS/MB)</b>	2	1	The No. 1 system must be operative. <b>NOTE:</b> All components must be operative for a VHF Navigation System to be considered operative.

Table 4.15. Oxygen.

<b>System Item</b>	<b>Installed</b>	<b>Required</b>	<b>Remarks or Exceptions</b>
<b>Liquid Oxygen System</b>	1	1	Quantity: 5 liters minimum or as Directed in <b>Paragraph 5.21.</b>
<b>Oxygen Regulators</b>	10	3	All crew member occupied positions must have an operable regulator.

Table 4.16. Pneumatic.

System Item	Installed	Required	Remarks or Exceptions
Bleed Air Augmenter Valve	4	3	One may be inoperative provided: (1) Affected valve is CLOSED and (2) All Nacelle Shut Off Valves are operative.
	4	0	May conduct a one-time flight to repair facility provided flight is conducted unpressurized (Manual / Open) and with no icing forecast.
Bleed Air Divider Valve	1	0	May be inoperative provided: (1) Affected valve is OPEN (2) Both Wing Isolation Valves are operative.
Bleed Air Pressure Indication	1	1	
Bleed Air Environmental Control System Electronic Controller	1	1	One channel may be inoperative.
Nacelle Shutoff Valve	4	4	
Wing Isolation Valve	2	1	One may be inoperative provided: (1) Affected valve is OPEN and (2) Divider Valve is operative.

Table 4.17. System Integration and Display.

System Item	Installed	Require	Remarks or Exceptions
Avionics Management Unit (AMU)	2	1	<b>Note:</b> All displays and data fields must be operative for the Associated Avionic Management Unit (AMU) to be considered operative.
Bus Adapter Unit (BAU) Type I	6	4	BAU 3 (daytime only) and/or 6 will be used as replacements or can be failed (swap modules). 1, 2, 4, & 5 must be operational.
Bus Adapter Unit Type II	4	4	
Bus Interface Unit (BIU)	2	2	

<b>Communication / Navigation / Breaker Panel (CNBP)</b>	1	1	<b>NOTE:</b> All displays and data fields must be operative for the CNBP to be considered operative. However, when an input is not present and the correct 'data not available' or 'fail' indication is displayed, the CNBP may still be considered operative provided the failed indication is not required for the current mission or flight.
<b>Communication / Navigation / Identification Management Unit (CNI-MU)</b>	3	2	One may be inoperative unless required for mission accomplishment.  <b>NOTE:</b> All components required for mission accomplishment must be operative for a CNI-MU to be considered operative.
<b>Communication / Navigation / Identification System Processor (CNI-SP)</b>	2	1	One may be inoperative for one time flight to repair facility.
<b>Data Bus, (1553B)</b>			
a. Avionics Bus	2	2	
b. Communication / Navigation Bus	2	2	
c. Display Bus	2	2	
d. Electronic Warfare Bus	1	0	Unless required for mission accomplishment.
e. Inter-processor Communication Bus	1	1	
f. Panel Bus	2	2	

	<b>Installed</b>	<b>Require</b>	<b>Remarks or Exceptions</b>
<b>HDD (#1-#4)</b>	4	3	One may be inoperative provided the HUD on the affected side is fully operational.  <b>NOTE:</b> All data fields and displays must be operative for the associated HDD to be considered operative. However, when an input is not present and the correct 'data not available' or 'fail' indication (which may be a blank or removal of the indication) is displayed, the affected HDD may still be considered operative provided the failed indication is not required for the current mission.



<b>HDD (#5-#6)</b>	2	0	Consider mission impact.
<b>Heads Up Display (HUD)</b>	2	1	One may be inoperative provided: (1) Both HDDs on the affected side are fully operational. (2) The pilot flying HUD must be operational for CAT II operations.
	2	0	Both may be inoperative provided: (1) Heads Down Displays (HDDs) #1 through #4 are operative (including operative independent PFDs in the pilot and copilot positions). (2) Forecast weather at destination is at or above Category I (CAT I) approach minimums.
a. HUD Control Panel	2	0	May be inoperative provided the associated HUD is considered inoperative.
<b>Mission Computer</b>	2	2	One may be inoperative for one time flight to repair facility.

**Table 4.18. Auxiliary Power Unit.**

<b>System Item</b>	<b>Installed</b>	<b>Required</b>	<b>Remarks or Exceptions</b>
<b>AC Generator, APU</b>	1	0	May be inoperative provided: (1) APU electrical power is not required and (2) External electrical power or aircraft battery power must be available for starting engines.
<b>Auxiliary Power Unit</b>	1	0	May be inoperative provided: (1) APU bleed air or electrical power is not required and (2) An alternate air source and external electrical power or aircraft battery power must be available for starting engines.
<b>Bleed Air System, APU</b>	1	0	May be inoperative provided (1) APU bleed air is not required and (2) An alternate air source must be available for starting engines.
<b>Inlet Door, APU</b>	1	0	May be inoperative provided: (1) Inlet Door can be operated manually and, (2) Inlet Door is secured CLOSED prior to departure,  <b>OR</b> (1) Inlet Door is secured CLOSED and (2) APU is considered inoperative.

Table 4.19. Doors.

System Item	Installed	Required	Remarks or Exceptions
Cargo Ramp and Door System	1	1	Warning light, latching mechanisms, and locking systems will be operative for pressurized flight.  <b>NOTE:</b> Aircraft will not take-off with a malfunctioning ramp lock system, with cargo on the ramp. Aircraft may continue to destination if ramp locks malfunction in flight. Repair lock malfunction or remove cargo from ramp prior to continuing flight operations. Do not pressurize the airplane if the ramp locks fail to lock.
	1	0	Unpressurized flight, with no cargo on the ramp, may be performed with a cargo ramp lock malfunction when mission requirements dictate.
System Item	Installed	Require	Remarks or Exceptions
a. Ramp Latches	10	9	One may be inoperative provided: (1) All remaining latches are operative, (2) Latch Warning System is operative, (3) Ramp is verified CLOSED and LATCHED before each departure, (4) Cabin differential pressure is limited to 5 in. hg and (5) No cargo is carried on the ramp.
<b>Cargo Door and Ramp Indicators</b>			
a. Ramp/Door FULL Light	1	0	May be inoperative provided: MFC D "RAMP & DOOR FULL OPEN" ACAWS message can be used,  <b>OR</b> Ramp position airdrop light (aft cargo comp.) is operative.
b. Ramp Position Airdrop Light	1	0	May be inoperative provided: MFC D "RAMP & DOOR FULL OPEN" ACAWS message can be used,  <b>OR</b> Ramp/Door FULL Light (flight station) is operative.

c. Ramp Warning Light	1	0	May be inoperative provided: (1) ACAWS RAMP OPEN PRESSURIZED and (2) RAMP OPEN 250 messages are operative, <b>OR</b> Ramp is verified CLOSED and LATCHED before each departure, <b>OR</b> Aircraft is operated unpressurized.
<b>Cargo Door and Ramp Sensors</b>			
a. ADS Arm Position Switches	2	0	Must be operative for airdrop and combat offload missions.
<b>Crew Entrance Door</b>	1	1	
a. Door Warning Light	1	0	May be inoperative provided the ACAWS CREW DOOR OPEN messages are operative.
<b>System Item</b>	<b>Installed</b>	<b>Required</b>	<b>Remarks or Exceptions</b>
<b>Paratroop Door</b>	2	0	May be inoperative provided affected Door is secured CLOSED and Latched, and the exit is not required to meet minimum emergency exits per number of passengers carried. Windows will be free and clear of debris and scratches.
a. Door Warning Light	2	0	May be inoperative provided the associated ACAWS L TROOP DOOR OPEN 250 or R TROOP DOOR OPEN 250 message is operative.

Table 4.20. Propellers.

System Item	Installed	Require	Remarks or Exceptions
<b>Propeller</b>	4	4	
<b>Propeller Control Panel</b>	1	0	May be inoperative provided control is available through the associated Soft Panel.
a. Propeller Control Switch	4	0	May be inoperative provided control is available through the associated Soft Panel.
b. Prop Sync Switch	1	0	
<b>Propeller Synchronizing</b>	1	0	

Table 4.21. Powerplant.

System Item	Installed	Required	Remarks or Exceptions
-------------	-----------	----------	-----------------------

<b>Automatic Thrust Control System (ATCS)</b>	1	1	If ATCS is degraded, a component/sensor has potentially failed. If maintenance is not available and takeoff is necessary, flight with ATCS DEGRADED (Caution) must be authorized by the OG/CC. Operation with ATCS inoperative procedures will be followed.
<b>Engine Assembly</b>	4	4	
<b>Engine Controls</b>			
a. Engine Start Panel	1	0	May be inoperative provided control is available through the associated Soft Panel.
b. Full Authority Digital Electronic Controls (FADEC) Panel	1	1	
c. Low Speed Ground Idle Switch	4	0	
d. Oil Cooler Flap Indications	4	0	May be inoperative provided oil temp indication(s) is/are operational for affected oil cooler flap(s).
<b>System Item</b>	<b>Installed</b>	<b>Required</b>	<b>Remarks or Exceptions</b>
<b>Engine Indicating System</b>			
a. Fuel Flow Indication	4	4	
b. Gas Generator Speed	4	4	
c. Horse Power Indication	4	4	
d. Measured Gas Temperature (MGT) Indication	4	4	
e. Oil Pressure Indication, Engine	4	4	
f. Oil Pressure Indication, Gearbox	4	4	
g. Oil Quantity Indication	4	0	May be inoperative provided the oil quantity is verified before flight.
h. Oil Temperature Indication	4	4	
i. Power Turbine Speed (NP) Indication	4	4	

<b>Engine Oil System</b>			
a. Oil Cooler Flap Automatic Control	4	0	May be inoperative provided Oil Cooler Flap Manual Control is operative.
b. Oil Cooler Flap Manual Control	4	4	
<b>Full Authority Digital Electronic Controls (FADEC)</b>	8	7	<p>One may be inoperative provided:</p> <p>(1) all dedicated sensor input and control logic is serviceable to/from the operative FADEC on the engine with lost redundancy,</p> <p>(2) ATCS Inoperative Takeoff procedures are carried out</p> <p>(3) All eight engine FADECs must be serviceable for auto shutdown to be operative.</p> <p style="text-align: center;"><b>NOTE:</b></p> <p>ATCS will be degraded. If maintenance is not available and takeoff is necessary, flight with ATCS DEGRADED (Caution) must be authorized by the OG/CC.</p>
<b>Nacelle Interface Unit (NIU)</b>	4	4	

Table 4.22. In-Flight Refueling System.

System/Item	Installed	Require	Remarks/Exceptions/Limitations
<b>Universal Aerial Refueling Receptacle Slipway Installation (UARRSI) System</b>	1	0	<p>System required for in-flight refueling.</p> <p style="text-align: center;"><b>NOTE:</b></p> <p>The Override signal amplifier will not be used for training flights.</p>

Table 4.23. Defensive Systems and Situational Awareness Equipment.

System Item	Installed	Require	Remarks or Exceptions
<b>Countermeasures Dispensing System (CMDS)</b>	1	0	Consider mission impact. Check Special Instructions (SPINS).
<b>CMDS Remote Dispense Switches</b>	3	0	Consider mission impact. Check SPINS.
<b>Defensive Systems Control Panel</b>	1	0	Consider mission impact. Check SPINS.
<b>Missile Warning System</b>	1	0	Consider mission impact. Check SPINS.

<b>Radar Warning Receiver</b>	1	0	Consider mission impact. Check SPINS.
<b>LAIRCM</b>	1	0	Consider mission impact. Check SPINS.

## Chapter 5

### GENERAL OPERATING PROCEDURES

**5.1. Aircrew Uniforms.** See AFI 11-301, Vol 1, *Aircrew Flight Equipment (AFE) Program*, for minimum aircrew clothing requirements. All aircrew members will have flight gloves readily available. (T-3) When the DoD Foreign Clearance Guide (FCG) requires civilian attire, dress conservatively.

**5.2. Personal Requirements and Professional Equipment.**

5.2.1. Passports. Carry passports on missions when required by the FCG.

5.2.2. Immunizations. Aircrew members will ensure they meet immunization requirements for the mission. (T-2)

5.2.3. Identification Tags. Identification tags should be worn around the neck or carried in a flight suit pocket.

5.2.4. Restricted Area Badges. Carry the restricted area badge on all missions (except actual combat missions). Display the badge only in designated restricted areas. (T-3)

5.2.5. Tool and Airdrop Kits. A tool kit will be on board for all flights. (T-3) Individual units will establish requirements for tools to be included in these kits and the crew member responsible for the kit (AFRC aircraft tool kits/aircraft Hostile Environment Repair Kit (HERK) satisfy this requirement). One LM airdrop kit will be on board for aerial delivery missions. (T-3)

5.2.6. Hostile Environment Repair Kit. Refer to AFSOCMAN 11-201, Hostile Environment Repair Procedures. One HERK will be on board for all OCONUS and contingency deployment missions. (T-3) Units will identify where the HERK will be stored on the aircraft in the local supplement to this AFMAN. (T-3) The LM will ensure the HERK is on board and serviceable (secured) during the aircraft preflight prior to departure. (T-3)

5.2.7. Aircrew will carry a headset, helmet, oxygen mask, watch and operable flashlight on all flights. (T-3)

5.2.8. Crew members will not wear scarves, wigs, hairpieces, rings, ornaments, pins, clips, other hair fasteners or earrings in the aircraft or on the flight line. (T-3) **Exception:** Plain elastic hair fasteners or plastic barrettes are allowed, providing they do not interfere with the wearing of headsets or helmets, or the donning of oxygen equipment. All devices will be accounted for before and after flight. (T-3)

**5.3. Aircrew Publications Requirements.** PIC will ensure the publications specified in **Table 5.1** are current and available on the aircraft via paper or electronic means for all missions. (T-3) Each individual aircrew member will ensure they have a current crew position checklist (ex. 1C-130(M)J-1CL-1) as required in **Table 5.1** (T-3) Units may specify additional publications in their local supplement. Refer to AFI 11-202, Vol 3 MAJCOM SUP for electronic flight bag guidance and procedures.

**Table 5.1. Aircrew Publications.**

<b>Publication</b>	<b>Aircrew</b>
1C-130(M)J-1CL-1, <i>Pilots/CSO Checklist</i>	Pilot/CSO
1C-130(M)J-1CL-2, <i>Loadmaster Checklist</i>	Loadmaster
AFI 11-202, Vol 3, MAJCOM SUP	On Aircraft
AFMAN 11-2MC-130J Vol 3, <i>MC-130J Operating Procedures</i>	On Aircraft
TO 1C-130(M)J-1, <i>Flight Manual</i>	On Aircraft
TO 1C-130(M)J-1-1, <i>Performance Manual</i>	On Aircraft
TO 1C-130(M)J-1-4, <i>Communications / Navigation / Identification-Management System (CNI-MS)</i>	On Aircraft
ATP-56(C), North Atlantic Treaty Organization (NATO) <i>Air-to-Air Refueling Procedures</i>	On Aircraft
AFTTP 3-3.E/MC-130J, <i>Combat Aircraft Fundamentals E/MC-130J</i>	On Aircraft
AFI 13-217, <i>Drop Zone and Landing Zone Operations</i>	On Aircraft
AFI 11-231, <i>Computed Air Release Point Procedures</i>	On Aircraft
TO 1C-130(M)J-9, <i>Cargo Loading Manual</i>	On Aircraft
TO 1C-130(M)J-9CL-1, <i>Cargo Loading Checklist USAF Series C-130J Aircraft</i>	Loadmaster
TO 1C-130J-5-2, <i>Load Data Manual</i>	On Aircraft
AFSOCMAN 11-201, <i>Hostile Environment Repair Procedures</i>	On Aircraft
AFMAN 11-2MC-130J, Vol 1, <i>MC-130J Aircrew Training</i>	On Aircraft
AFMAN 11-2MC-130J, Vol 2, <i>MC-130J Aircrew Evaluation Criteria</i>	On Aircraft
DoDI 4140.25-M, Vol 2 <i>DoD Management of Bulk Petroleum Products, Natural Gas, and Coal</i>	On Aircraft
ATP-3.3.4.2, <i>Air-to-Air Refuelling</i>	On Aircraft
AMC Airfield Suitability and Restrictions Report (ASRR)	On Aircraft



DoDI 4515.13-R, <i>Air Transportation Eligibility</i>	On Aircraft
DoD Foreign Clearance Guide (when applicable)	On Aircraft

**5.4. Aircrew Intelligence Briefing.** Aircrews will receive an intelligence briefing that will emphasize terrorist, enemy, and friendly political and military development in the area in which they will be flying. (T-3) Obtain timely intelligence updates prior to entering a specific AOR. In theater, aircrews should receive intelligence updates on initial arrival at a forward operating location (FOL), or en route stop, and thereafter when significant developments occur. Report information of possible intelligence value to the local intelligence office as soon as practical to ensure timely dissemination of mission reports (MISREPs). (T-3)

**5.5. Flight Crew Information File.** Review Volume I, of the Flight Crew Information File (FCIF) before all missions. If material has been added to the FCIF since the last review, enter the latest FCIF item number, date, and initials on the AF Form 4121, *FCIF Currency Record*, or approved electronic FCIF database (PEX, etc.).

5.5.1. Crew members delinquent in FCIF and joining a mission en route will receive an FCIF update from their primary aircrew member counterpart on that mission. (T-3) Instructor pilots flying with general officers are responsible for briefing appropriate FCIF items.

5.5.2. Crew members that do not have a unit FCIF card (not assigned or attached to the unit) or approved electronic equivalent will certify FCIF review by entering the last FCIF number and their initials beside their name on the file copy of the flight authorization. (T-3)

**5.6. Aircraft Mission Kits.** Units will maintain one mission kit per aircraft. (T-3) The entire mission kit may be stored electronically on an approved e-tools device and must follow the guidelines as established in previous paragraphs. Prior to off-station departures, the PIC or a designated representative will ensure a current mission kit is on board the aircraft in electronic or paper format. (T-3) The kit will contain, but is not limited to, the items listed in [Table 5.2](#) (T-3)

**Table 5.2. Aircraft Mission Kit.**

Section I: AF Forms	Section II: DD Forms
15, <i>USAF Invoice</i>	175, <i>Military Flight Plan</i>
70, <i>Pilot's Flight Plan and Log</i>	175-1, <i>Flight Weather Briefing</i>
457, <i>USAF Hazard Report</i>	1385, <i>Cargo Manifest</i>
651, <i>Hazardous Air Traffic Report</i>	1801, <i>DoD International Flight Plan</i>
791, <i>Aerial Tanker In-flight Issue Log<sup>1</sup></i>	2131, <i>Passenger Manifest</i>
1297, <i>Temporary Issue Receipt</i>	CBP 7507, <i>General Declaration (Outward/Inward) Agriculture, Customs, Immigration and Public Health</i>
2282, <i>Statement of Adverse Effect – Use of Government Facilities</i>	
3823, <i>Drop Zone Survey</i>	
4015, <i>HARP Computation<sup>2</sup></i>	

4018, CARP Computation <sup>2</sup> 4051, Low-level Flight Plan and Log <sup>2</sup> 4108, C-130 Fuel Log <sup>2</sup> 4116, C-130 Flight Plan Record <sup>2</sup> 4118, SCA Planning Form <sup>2</sup> 4139J, Special Operations Refueling CS In-flight Worksheet <sup>2</sup>	
<b>Section III: MAJCOM Forms</b>	
Reserved for MAJCOM specific forms	
<b>Section IV: Miscellaneous</b>	
Foreign Nation Custom Form (when applicable)	
All applicable local forms	
<b>Note 1:</b> Applicable to tanker aircraft only.	
<b>Note 2:</b> May be substituted for approved computer flight planning forms	

### 5.7. Route Navigation Kits.

5.7.1. The route navigation kits will contain sufficient quantities of material to cover the planned mission and global operations as required. The minimum contents of route navigation kits are in [Table 5.3](#) Paper copies of the Route Navigation Kit will be carried when electronic quantities (IAW AFI 11-202, Vol 3 MAJCOM SUP) are not available. (T-3)

5.7.2. On local unit training sorties, local area navigation kits may be used in lieu of route navigation kits in [Table 5.3](#) Contents of these kits will be determined by the unit. (T-3)

**Table 5.3. Route Navigation Kit Contents (Applicable to area of operation).**

Item (Applicable to Area of Operations)	Quantity Required
FLIP Planning (GP, AP/1, AP/2, AP/3, AP/4)	1
FLIP Instrument Flight Rules (IFR) Supplement	2
FLIP Flight Information Handbook (FIH)	2
FLIP En route Charts (High and Low)	2
FLIP Area Charts (Terminal)	2
FLIP Instrument Approach Procedures (High and Low)	3*
Standard Terminal Arrival (STAR)	3*
Operations Report (OPREP)-3 Report Format	1
Maps and Charts	As Required
FLIP Visual Flight Rules (VFR) Supplement	1
*Two required when a CSO is not part of the crew. <b>Note:</b> Units may modify the kit to carry only FLIP documents for the theater in which the mission will operate.	

## 5.8. Flight Plan/Data Verification.

5.8.1. Computer Flight Plan (CFP): Use CFP as the official source of performance, navigation, and climatic data, including en route wind information. If stand-alone computer based plans are used, each mission segment should utilize best wind data available. Use only MAJCOM validated CFPs.

5.8.1.1. Use CFPs to the maximum extent practical. Flight crews may manually compute flight plans. The PIC has final responsibility for flight plan accuracy and diplomatic clearance compliance.

5.8.1.2. Verify CFPs for route of flight and fuel computation accuracy before departure. All waypoint data retrieved from a database should be verified by one or more of the following methods:

5.8.1.2.1. Latitude/Longitude from current FLIP.

5.8.1.2.2. Bearing/distance from a flight plan.

5.8.1.2.3. Ground Based NAVAIDs.

5.8.1.3. When conducting Drop Zone (DZ)/Landing Zone (LZ) operations, both pilots or one pilot and CSO will verify CNI-MU CARP/LZ information with a valid DZ/LZ survey. (T-3) Refer to AFI 13-217, *Drop Zone and Landing Zone Operations* for DZ/LZ survey information/requirements/applicability. (T-2)

**5.9. Communications Security (COMSEC) and Classified Material.** Obtain and safeguard COMSEC and other classified/keying material required for the mission. Carry authenticators and IFF Mode IV codes, when flying into an Air Defense Identification Zone (ADIZ), participating in exercises, on overseas missions, deployments, and when specified in operation plans.

5.9.1. The base COMSEC custodian has access to the AFKAG 44/AFKAG 14 and can assist in obtaining the material required for the mission. Squadrons maintain the COMSEC material used on most missions. All squadron members that require access to COMSEC material will be properly trained. (T-3) Base/squadron COMSEC Responsible Officer (CRO) is the Point of Contact for current training requirements. Issue and turn-in of COMSEC is normally a function of the squadron CRO.

5.9.2. Store COMSEC in appropriately classified and secure facilities during en route stops. (T-3)

5.9.3. If possible destroy classified material and equipment prior to crash landing or bailout.

5.9.4. Remove classified/sensitive information (such as secure voice/DAMA, IFF, mission information) stored in all aircraft systems after mission completion and prior to leaving airplane. (T-3)

**5.10. Briefing Requirements.** Refer to the appropriate [Attachment 5](#), or TO 1-C-130(M)J-1 briefing guides for content. Crew members will not fly unless they attend the crew briefing. (T-3) Exception: When pre-mission requirements dictate, PIC may excuse certain crew members from the briefing. The PIC will ensure that those personnel receive a face-to-face briefing prior to engine start. (T-3)

**5.11. Call Signs.** Use Voice Call Sign Listing or as specified in mission directives/tasking for all missions except local area training missions. Use squadron or wing static call signs as directed for local area training missions. (T-3)

5.11.1. Aeromedical Evacuation. Preface call sign with "AIR EVAC" when patients are on board.

5.11.2. Search and Rescue. When tasked to participate in SAR operations, use the call sign "AIR FORCE RESCUE" plus the last five digits of the aircraft tail number. (T-3)

**5.12. Departure/Arrival Planning. Comply with AFI 11-202, Vol 3, and AFMAN 11-217, Vol 1, Instrument Flight Procedures. If using a flight plan furnished by another agency, the PIC and CSO will verify routes and flight altitudes to ensure proper terrain clearance. (T-3)**

**5.13. TOLD Verification Requirement. To verify CNI TOLD, both pilots will cross-check CNI TOLD INIT entries. (T-3)**

**5.14. Adverse Weather.**

5.14.1. Flight into areas of forecast or reported severe turbulence is prohibited.

5.14.1.1. Anytime wind shear may be encountered on departure or approach, it is recommended that aircrews select weather mode on one NAV RADAR display and wind shear mode on another NAV RADAR display.

5.14.1.2. The PIC is responsible for ensuring all passengers are seated, with seat belts fastened, when areas of moderate or greater turbulence are encountered or anticipated. **WARNING:** Serious injury may occur if passengers do not have their seat belts fastened and the aircraft encounters moderate or severe turbulence.

5.14.2. Flight into areas of forecast or reported severe icing is prohibited. Prolonged operation, such as cruise flight or holding, in areas of moderate icing should be avoided.

5.14.2.1. Do not takeoff under conditions of freezing rain or freezing drizzle.

5.14.2.2. Freezing precipitation, snow, freezing fog (consider equivalent to moderate icing), or temperatures near 0° C, may cause ice or frost to accumulate on aircraft surfaces. When an aircraft requires de-icing/anti-icing prior to takeoff, refer to the following:

5.14.2.2.1. Aircrews will only use de-ice and anti-ice fluids listed in their respective flight manual. (T-2) Aircrews will be familiar with, and follow all restrictions in their associated flight manual with respect to anti-ice/de-ice procedures and holdover times. (T-2)

5.14.2.2.2. Military (MIL)-A-8243 Type I and Type II de-icing fluids do not provide any anti-icing benefit, and therefore do not have holdover times.

5.14.2.2.3. In all cases, PICs will ensure a visual inspection of the aircraft is completed within 5 minutes of departure. (T-3)

5.14.3. Do not fly directly above (within 2,000 feet) thunderstorms or cumulonimbus clouds. (T-3) If unable to clear thunderstorms or cumulonimbus clouds by at least 2,000 feet vertically, avoid them by at least:

5.14.3.1. 20 NM at or above flight level (FL) 230.

5.14.3.2. 10 NM below FL 230.

5.14.3.3. 5 NM for tactical low-level operations. Avoid gust fronts and winds preceding a rapidly moving thunderstorm. **CAUTION:** Aircraft damage may occur 20 NM or more from any thunderstorms. Aircrews must familiarize themselves with information on thunderstorm development and hazards. Refer to AFH 11-203, Vol 1, *Weather for Aircrews*. (T-2)

5.14.4. The use of ground-based radar as a means of thunderstorm avoidance should only be used to assist in departing an inadvertently penetrated area of significant weather. It should never be considered a normal avoidance procedure. When relying exclusively on ground-based radar for weather avoidance, and the ground controller is unable to provide avoidance instructions, attempt to maintain VMC by:

5.14.4.1. Changing routing.

5.14.4.2. Diverting to alternate.

5.14.4.3. Declaring an emergency and requesting priority assistance.

**5.15. Risk Management (RM).** RM is a logic based, common sense approach to making calculated decisions on human, material, and environmental factors before, during, and after all operations. AF guidance on RM is contained in Air Force Pamphlet (AFPAM) 90-803, *Risk Management (RM) Guidelines and Tools*. PICs will accomplish RM worksheets IAW MAJCOM and local guidance as part of preflight activities. (T-3)

5.15.1. Flying units will develop a local RM program to include personal RM assessment for all missions. (T-3)

5.15.2. The PIC will ensure an RM assessment is accomplished by all crew members as part of preflight activities. (T-3)

**5.16. AFTO Form 781, Aerospace Vehicle Flight Data Record.** Review the AFTO Form 781 before applying power to the aircraft or operating aircraft systems. The Exceptional Release (ER) must be signed before flight. A maintenance officer, maintenance superintendent or authorized civilian normally signs the ER. If one of these individuals is not available, the PIC may sign the ER. Ensure that the DD Form 1896, *DoD Fuel Identaplate* and AIR card are on board the aircraft. (T-3)

5.16.1. One-Time Flights. An aircraft may be released for a one-time flight with a condition that might be hazardous for continued use, provided the aircraft is airworthy for one flight to a repair station. Refer to [Paragraph 4.5](#)

5.16.2. Authority to Clear a Red X. Aircrew are not normally authorized to clear a Red X. If a situation is encountered where the aircraft is on a Red X and qualified maintenance personnel are not available to clear it, the PIC may obtain authorization to clear the Red X from the home station Maintenance Group (MXG)/CC or designated representative, in accordance with TO 00-20-1.

5.16.2.1. At en route stations, loadmasters are authorized to clear Red X symbols for; intake and exhaust inspections, dust covers and plugs installed, and aircraft panels removed

and installed to facilitate other maintenance when qualified maintenance personnel are not available.

5.16.2.2. In-Process Inspections. Loadmasters must be aware of their responsibility to perform in-process inspections prior to the PIC clearing Red X symbols. During the assembly where further assembly will prevent the required inspection of the item, an in-process inspection will be performed. The inspection will be documented IAW TO 00-20-1. (T-3)

**5.17. Forms Management.** In addition to the procedures in TO 00-20-1 and AFI 11-401, the CSO/LM will assist the PIC in maintaining the AFTO Form 781. (T-3) Verify the exceptional release is signed before flight and resigned, if necessary, at en route stops.

5.17.1. After each flight, ensure the number of discrepancies (if any), landings, and flight duration time(s), etc., are entered on the AFTO form 781H, *Aerospace Vehicle Flight Status and Maintenance Document*. Review all AFTO form 781A discrepancies to ensure symbols, date discovered, and clear, detailed entries were entered and the discovered by blocks are completed for each discrepancy.

5.17.2. IAW, DoD Manual 4140.25-M Vol 2, *DoD Management of Bulk Petroleum Products, Natural Gas, and Coal*; AFI 23-201, *Fuels Management*; and AFI 23-111, *Management of Government Property in Possession of the Air Force*; AFMAN 23-110, *USAF Supply Manual*, Vol. 1, Pt 3; and AFI 11-253 *Managing Off-Station Purchases of Aviation Fuel and Ground Services*, all off-station fuel purchases (to include FARP and in-flight refueling) will be logged on AFTO form 781H and AF Form 664, *Aircraft Fuels Documentation Log* if applicable. (T-3)

5.17.3. IAW AFMAN 23-110, Vol 1 an aircrew member will record all in-flight transfers from C-130 tanker aircraft to any receiver aircraft on the AF Form 791, *Aerial Tanker In-Flight Log*. This form will also be accomplished for Forward Area Refueling Point (FARP) offloads and fuel jettison in excess of 1,000 lbs. Turn completed forms in during maintenance debrief. (T-3)

**5.18. Dash 1 Preflight.** Aircrew will conduct preflight inspection IAW TO 1C-130(M)J-1 (Dash 1). The aircrew Dash 1 preflight inspection, once completed, is valid for 72 hours provided the aircraft is sealed.

5.18.1. When an aircrew assumes a preflighted spare or quick-turn, a thorough visual inspection will be performed, paying particular attention to areas affected by maintenance or servicing. (T-3)

5.18.2. Dash 1 preflight inspections are normally done in preparation for flight by the aircrew assigned to fly the mission designated for that aircraft, that day unless approved by the DO or mission commander.

5.18.2.1. The following guidelines apply to aircrew assigned to preflight and/or seal aircraft. A crew should not preflight more than 4 aircraft in a 12-hour period. Refer to crew rest/flight duty period guidance in AFI 11-202, Vol 3. Aircrews performing preflight duties are normally afforded 12 hours rest between preflight shifts but will follow reduced crew rest guidance in AFI 11-202, Vol 3. (T-2)

5.18.2.2. Duties Not Including Flying (DNIF) crew members may accomplish preflights with the concurrence of the flight surgeon. It is the responsibility of the crew member to know his/her duty limitations. Crew members should have the flight surgeon document the DD Form 2992, *Medical Recommendation for Flying or Special Operational Duty*, appropriately IAW with AFI 48-123, *Medical Examinations and Standards*.

**5.19. Alert Aircraft Procedures.** Maintain aircraft on alert status as follows:

- 5.19.1. Park the aircraft in a designated alert parking area to expedite taxi and takeoff.
- 5.19.2. Aircraft preflight times should align the alert period and aircraft preflight validity period, eliminating the need to update the preflight during the alert period.
- 5.19.3. The alert aircraft may be flown for purposes other than actual alert missions provided the following conditions are met:
  - 5.19.3.1. Ensure sufficient fuel remains on board to meet alert commitments.
  - 5.19.3.2. Maintain communications with the primary controlling agency.
  - 5.19.3.3. If maintenance actions are not required, the aircraft can be resealed for alert once the thru-flight inspection is completed. In all cases, a new preflight is not required until the end of the initial preflight period.
- 5.19.4. If the alert aircraft is changed to a different preflighted/sealed aircraft, or an alert crew change occurs and the same aircraft remains on alert, the preflight or alert crew will, as a minimum, apply power to the aircraft and check the following systems (as applicable): (T-3)
  - 5.19.4.1. AFTO Form 781.
  - 5.19.4.2. Interior and exterior for proper configuration and special equipment.
  - 5.19.4.3. Fuel quantity.
  - 5.19.4.4. Survival and emergency equipment.
  - 5.19.4.5. Navigation and communication equipment.
  - 5.19.4.6. Liquid oxygen quantity.
  - 5.19.4.7. Hydraulic reservoirs and accumulator charges.
  - 5.19.4.8. Publications.
- 5.19.5. Should an aircraft remain on alert for more than 72 hours, a complete aircrew preflight is then required.
- 5.19.6. Once the aircraft is accepted for alert, the loadmaster will ensure an entry is made in the AFTO Form 781H, *Aerospace Vehicle Flight Report and Maintenance Document*, stating as a minimum, the date and time the aircraft was preflighted. (T-3)
- 5.19.7. Alert aircraft are off limits to all personnel except alert crew members, or designated crew members performing alert preparation duties. No maintenance may be performed on the aircraft without the approval of the unit/mission commander. Upon receiving orders to launch, the crew is required to check the area in which maintenance was performed prior to flight.

**5.20. Aircraft Servicing and Ground Operations.**

5.20.1. Aircraft Refueling. Crew members may perform refueling duties at austere locations or at stations without maintenance support. Aircrews should not refuel except in cases when maintenance support is not readily available and the mission would be delayed.

5.20.2. Concurrent Ground Operations. Simultaneous aircraft refueling/defueling and cargo loading or maintenance operations is authorized in accordance with AFI 21-101, *Aircraft and Equipment Maintenance Management*, TO 00-25-172, *Ground Servicing of Aircraft and Static Grounding/Bonding*, MDS specific TO and any established local procedures.

5.20.3. Liquid Oxygen Servicing. Under no conditions are crew members allowed to service liquid oxygen.

5.20.4. Forward Area Refueling Point Operations. Refer to AFI 11-235, *Forward Area Refueling Point (FARP) Operations*.

5.20.5. Fire Protection, Ground Operations and Crash Rescue.

5.20.5.1. The aircraft engine fire extinguisher system fulfills the minimum requirements for fire protection during engine start. If available, position a portable fire extinguisher for added fire protection.

5.20.5.2. A fireguard is required for all engine starts except normal APU starts. A crew member or ground controller may act as fireguard. (T-3)

5.20.6. Propulsion System Checks (Engine Runs). When conducting maintenance-requested propulsion system checks, comply with the following:

5.20.6.1. Aircrew/Maintenance Engine Runs. Mixed aircrew maintenance engine runs will not normally be accomplished. If conducted, review and use the maintenance TO procedures. The cargo door and ramp will be closed for all engine run-up's above flight idle.

5.20.6.2. Prior to conducting the checks, complete a risk management (RM) assessment and review risk mitigation actions. The minimum crew complement for the checks will be the crew complement required for aircraft taxi. Start with the preflight checklist and accomplish all checklists through before leaving the aircraft checklist. (T-3)

5.20.6.3. During the propulsion system checks, follow normal flight manual procedures and limitations (do not combine maintenance procedures/limitations into the checks). Set power as requested and relay instrument readings, but limit troubleshooting to the scope of the aircraft flight manual. Checks requiring functional check flight (FCF) procedures will be performed by FCF-qualified crews. (T-2)

5.20.6.4. When conducting propulsion system checks in areas of reduced traction, ensure all personnel on board are seated with lap belts fastened. (T-3)

5.20.7. Towing. Aircrew members will not normally participate in towing operations. The PIC will coordinate with the senior maintenance officer or superintendent to ensure the towing supervisor and crew are qualified. (T-3) At non-AF installations, the PIC must have approval from the airfield operations officer or manager prior to towing. (T-3) The PIC will ensure the tow team supervisor briefs all personnel on their duties and the associated hazards. (T-3) Proper checklists will be used. If any doubt exists as to the qualification of tow team personnel or the safety of the operation, make no attempt to tow the aircraft until qualified AF personnel



can be located. Under no circumstances will any crew member act as the towing supervisor. (T-3)

5.20.8. When thunderstorms are reported within 10 NM of the airfield, only operations leading to an immediate engine start and departure may continue. However, personnel must be prepared to cease all activities in the event lightning within 5 NM is declared. When advised of lightning within 5 NM of the airfield, all flight line activities will cease and personnel will seek shelter. (T-3) The aircraft is a grounded form of shelter.

5.20.9. Aircraft taxiing to parking or hot cargo when lightning is declared within 5 NM should not expect a marshaller. The aircrew will hold in place or proceed to parking if clearance is assured. (T-3) Remain in the aircraft if ground transportation cannot be arranged. Time permitting, coordinate with Base Operations if the aircraft will be parked in a location other than the one assigned. (T-3)

**5.21. Aircrew Flight Equipment and Oxygen Requirements.** The PIC or designated representative will ensure appropriate serviceable protective clothing, aircrew flight equipment, survival equipment and Dash 21 maintained equipment for the entire mission are available prior to flight and all personnel are briefed or trained in their use prior to departing home station. (T-3) Prior to departing home station and following en route crew changes, the PIC or designated representative will review the AFTO Form 46, *Aircrew Flight Equipment*, to ensure all required equipment is on board and required inspections have been completed. (T-3) The PIC or designated crew member will document and ensure missing aircrew flight equipment is annotated in both the AFTO Form 781A and AFTO Form 46. (T-3)

5.21.1. Oxygen. Minimum 5 liters for all flights. Oxygen on board for takeoff must be sufficient to accomplish the planned flight from the Equal Time Point (ETP) to a suitable recovery base. (T-2) On missions with passengers, carry passenger emergency oxygen systems (Passenger Oxygen Kits (POK), Emergency Portable Oxygen System (EPOS), or other approved system) if flight above FL 250 is anticipated. Do not block access to these systems during flight. Reference AFI 11-409, *High-Altitude Airdrop Mission Support Program*, for aircrew pre-breathing requirements. Aircrews will comply with AFI 11-202, Vol 3 oxygen guidance. (T-2) **WARNING:** The POK does not protect the wearer from smoke or fumes.

5.21.1.1. Crew members will accomplish a communications and operations check of their oxygen system prior to flight, which will remain connected and readily available when occupying a primary crew position. (T-2) Walk around bottles do not satisfy this requirement.

5.21.1.2. For the purposes of oxygen requirements, consider Mission Essential Personnel (MEP) as passengers.

5.21.2. Life Rafts. Ensure sufficient wing well life rafts are onboard to accommodate all passengers and aircrew members on overwater flights. (T-2)

5.21.3. Life Preserver Units. For overwater flights, ensure a sufficient quantity of life preservers are onboard for all passengers and crew members. (T-2) overwater, Life Preserver Units (LPU) will be sized and readily available at the crew member's station, and worn whenever below 2,000 feet overwater (except for takeoff, approach and landing). (T-2) Crew members wearing a parachute or harness during air refueling overwater will also wear a LPU. For overwater missions carrying children and infants, ensure the appropriate number and types

of LPUs are onboard. **Note:** Parachutists will provide their own LPUs. (T-2) The flying unit will ensure the supported unit is aware when route of flight requires the use of LPUs. (T-2) **Note:** Infil/Exfil operations may preclude issuing aircraft LPUs to user personnel.

5.21.4. Anti-exposure suits. Anti-exposure suits will be available during overwater flights when route of flight is beyond power-off gliding distance from land and the water temperature is 60° Fahrenheit (F) or below. (T-2) **Exception:** Anti-exposure suits are not required when only the approach or departure is flown overwater. If the water temperature ranges between 51° F and 60° F, the unit or mission commander may waive or extend the anti-exposure suit requirement after consideration of all risk factors. (T-2)

5.21.5. Parachutes. MC-130J aircraft will be configured with one parachute for each crew member. Units will dictate use of parachutes during combat or acceptance flights. (T-2)

5.21.6. Restraint Harness.

5.21.6.1. Personnel performing duties near an open door in-flight will preflight and wear a parachute or restraint harness. Wear a restraint harness during operations below 1,000 feet Above Ground Level (AGL). Fit the restraint harness and adjust the lifeline prior to takeoff time. (T-2) **WARNING:** Position one restraint harness forward and aft of FS 245 in event the crew entrance door must be inspected during flight. This harness must be sized and fitted by a crew member prior to flight IAW TO 1C-130(E)J-1. (T-2) **Note:** Connect the hook to a point that will preclude the wearer from exiting the aircraft in the ADS position. When anticipating moving aft of the ramp hinge the life line will be connected no further aft than Fuselage Station (FS) 737. (T-2)

5.21.6.2. The restraint harness lifeline may be attached to an unused, preflighted anchor cable that has an anchor cable stop positioned and taped at FS 737. Do not connect the lifeline to an anchor cable that has a parachute static line(s) attached to it for an airdrop.

5.21.7. Survival Kits/Vests. Configure all aircraft with one survival kit (ML-4) for each aircrew member for flights conducted beyond gliding distance of land. Survival vests may be used in lieu of survival kits if the mission will not be conducted beyond gliding distance of land. (T-2)

5.21.8. Helmets. Refer to the Special Instructions (SPINS) for the requirement to wear helmets during contingency and combat missions. The unit commander or mission commander may direct the wear of helmets as required.

5.21.8.1. Mobile crew members in the cargo compartment will wear helmets during all actual airdrop operations from the Twenty-Minute Warning through the completion of the airdrop checklist. **Exception:** Helmet is not required for Standard Airdrop Training Bundles (SATB)/High Altitude Low Opening (HALO) personnel drops (when no oxygen is required or door bundles are used).

5.21.8.2. **WARNING:** Personnel in the cargo compartment will not be seated under the anchor cables or static line retriever cables that are rigged for use unless cargo compartment configuration or mission requirements dictate otherwise. In that event, protective headgear will be worn. Personnel will not position themselves directly under the center anchor cable supports (A-frames, FS 737) during personnel or equipment airdrops requiring the use of the anchor cable. (T-2)

5.21.8.3. **Note:** When conditions require personnel in the cargo compartment to wear protective headgear, the flight helmet will be worn with the chinstrap fastened. (T-2)

5.21.9. Eye Protection. All personnel aft of FS 617 should wear eye protection during any mission requiring doors to be open.

**5.22. Departure Briefing.** The pilot making the takeoff will brief the crew in accordance with appropriate AFMAN 11-2MC-130J, Vol 3, [Attachment 5](#) or TO 1-C-130(M)-1 briefing (T-3)

**5.23. Traffic Collision Avoidance System/Enhanced Traffic Collision Avoidance System (ETCAS) Operations.** Mission requirements may allow selection of Traffic Advisory (TA) only when operating from parallel runways, in the visual traffic pattern, air refueling, or in formation since the proximity to aircraft may result in unwarranted resolution Advisory (RA)s. Excessive climb and descent rates could lead to inadvertent TA/RA. Reducing climb/descent rates near level off can limit inadvertent TCAS advisories.

**5.24. Communications Policy.** The AF does not give a promise of confidentiality to aircrews regarding their recorded aircraft crew communications.

5.24.1. All crew members will monitor interphone. Crew members will notify the PIC before going off headset and when back on headset. (T-3)

5.24.1.1. Do not discuss classified information on the interphone during radio transmissions. Aircrews should not discuss classified information when using the Mission Record Playback System (MRPS) as it records all selected audio from the CSO station Digital ICS.

5.24.1.2. Non-aircrew members may monitor interphone or radio transmissions only when specifically approved by the PIC. The PIC will brief communications policy to these personnel prior to flight. (T-3) The PIC will ensure personnel on headset or within listening distance are cleared prior to discussing classified information over interphone. (T-3)

5.24.1.3. Sterile Cockpit. Limit conversation to that essential for crew coordination and mission accomplishment during critical phases of flight, to include taxi.

5.24.1.4. LMs may clear off interphone with PIC's approval after acknowledgement of the 20 minute warning. After completing the 20 minute checklist items, the primary LM will remain on interphone throughout completion of the checklist. (T-3)

5.24.2. Command Radios:

5.24.2.1. The Pilot Monitoring (PM) normally makes all ATC radio calls. The pilot (or designated crew member) will inform the crew which radio is primary. (T-3) All crew members will monitor the primary radio unless specifically directed to do otherwise by the PIC. The PIC will designate crew members required to monitor the.

5.24.2.2. HF and/or SATCOM radio. (T-3)

5.24.2.3. During emergencies, monitor simultaneous UHF and VHF transmissions, if able, when operating in a terminal area under radar control.

5.24.2.4. Both pilots will monitor UHF and VHF guard emergency frequencies to the maximum extent possible. (T-3)

5.24.2.5. One of the pilots or CSO will record and read back all ATC clearances. (T-3)  
This may be disregarded when ATC instructions require immediate execution or when such action interferes with timely completion of more important duties.

5.24.3. Communication Reports. Comply with mandatory communication and reporting procedures in the Flight Information Handbook.

**5.25. In-Flight Emergency Procedures.** Report deviations from directives that occur as a result of an emergency, in accordance with AFI 11-202, Vol 3 and this manual.

5.25.1. Notification of Controlling Agencies. When practical after completing the aircraft emergency action checklist and associated actions, furnish the controlling agency and appropriate Command and Control Center (CCC) with a description and extent of the difficulty, assistance required, intentions, and any further pertinent information.

5.25.1.1. The PIC may initiate a Conference Hotel IAW **Table 5.4** when additional expertise is necessary to cope with emergencies or other conditions.

**Table 5.4. Conference Hotel for All C-130 Variants.**

	<b>Procedure</b>	<b>Contact</b>
<b>Primary</b>	Call Lockheed Martin Technical Representative:	Comm: (770) 494-1705
<b>Secondary</b>	Call Robins AFB Command Post and ask to be connected to Lockheed Martin Conference Hotel. Command Post maintains a current contact roster for Lockheed Martin subject matter experts.	DSN: 497-2612 or Comm: (478) 327-2612

5.25.2. Continued Flight with Engine Loss. A flight may proceed on three engines to its destination if two-engine capability exists, favorable operating conditions prevail en route and at the point of intended landing, and a suitable alternate airfield is available at all times. If these conditions cannot be met, the flight will terminate at the nearest facility (preferably military) which, in the judgment of the PIC, offers safe and favorable operating conditions. (T-2)

5.25.3. Fuel Jettisoning. Fuel will not be jettisoned except in combat, emergency conditions, or rescue missions requiring gross weight reduction. Advise ATC should it become necessary to jettison fuel.

**5.26. Need for Medical Assistance.** When a person on board the aircraft requires medical care, the PIC will inform the station of next intended landing in sufficient time so medical personnel may meet the aircraft. (T-3)

5.26.1. Suspected Laser Exposure. If exposed to a laser, the PIC will ensure appropriate command and control, intelligence, safety, and medical agencies are notified as soon as possible. (T-3) Aircrew who suspect exposure to laser radiation from either friendly or hostile sources should report to the Flight Surgeon's Office or nearest emergency room where individual can be examined by an ophthalmologist immediately upon landing.

5.26.2. Decompression sickness. If anyone onboard exhibits signs of decompression sickness, immediately proceed to the nearest base at which qualified medical assistance is available. (T-3) Advise the control tower of the emergency and request a flight surgeon and an ambulance to meet the aircraft.

**5.27. Arrival.** Before descent into unfamiliar areas, the pilots and CSO will review appropriate terrain charts to increase aircrew situational awareness of obstructions. (T-3) Primary crew members will not be involved in duties other than aircraft operations, descent and approach monitoring, and required checklist items from the initial descent point to landing. (T-3)

5.27.1. Flight Instrumentation Requirements.

5.27.1.1. Full flight instrumentation for a CAT I ILS and precision radar approach (PAR) includes a HUD or PFD at each station, and no shared Central Air Data Computer (CADC) or Inertial Navigation Unit (INU) attitude reference.

5.27.1.2. Full flight instrumentation for a CAT II ILS includes an operational HUD in the Pilot Flying (PF) position, a HUD or PFD at the Pilot Monitoring (PM) position, and meeting the flight manual CAT II ILS criteria.

5.27.1.3. Aircraft are limited to a Decision Height/Minimum Descent Altitude (DH/MDA) based on a Height Above Touch-down (HAT) of 300 feet and Runway Visual Range (RVR) 40 or 3/4 Statute Miles (SM) visibility (1,220 meters) with no RVR if full flight instrumentation is not operational.

5.27.2. ILS Precision Runway Monitor (PRM) Approaches. Both pilots must be certified to conduct an ILS PRM approach. Comply with the following operational procedures: (T-2)

5.27.2.1. Two operational VHF communication radios are required.

5.27.2.2. The approach must be briefed as an ILS/PRM approach. (T-2)

5.27.2.3. If unable to accept an ILS PRM approach clearance, contact the Federal Aviation Administration (FAA) ATCSCC at 1-800-333-4286 prior to departure time to obtain a pre-coordinated arrival time. Pilots who arrive at a PRM airport unable to accept PRM approach clearance, who did not contact ATC prior to departure, should expect an ATC directed divert to a non-PRM airport.

5.27.2.4. All breakouts from the approach shall be hand flown. (T-2) Autopilots shall be disengaged when a breakout is directed. (T-2)

5.27.3. CAT II ILS Procedures. Decision Height (DH) is based on radar altitude. Minimum HAT is 100 feet. Minimum Runway Visual Range (RVR) is 1,200. Maximum crosswind limitation is 10 knots. Crosswind of 15 knots may be used for training approaches (requires weather of 200 – 1/2 or greater).

5.27.3.1. The following airfield and aircraft equipment must be operational (AFI 11-230, *Instrument Procedures*). (T-2)

5.27.3.1.1. Approach lights.

5.27.3.1.2. Runway centerline lighting.

5.27.3.1.3. High intensity runway lights or touchdown zone lights.

5.27.3.1.4. Approach end transmission meter.

5.27.3.1.5. ILS far field monitor.

5.27.3.1.6. Sequenced flashers.

5.27.3.2. Aircrews will not execute an Instrument Meteorological Condition (IMC) CAT II ILS to minimums unless both pilots are qualified and current in CAT II ILS. (T-3)

5.27.3.3. When performing CAT II ILS procedures on a CAT I ILS for training/evaluations, the DH is the HAT for the CAT I ILS. **Note:** For Category II (CAT II) approaches, cross-check offside Radar Altimeter if not accomplished previously on approach (i.e., 1,000 AGL).

5.27.4. Refer to AFI 11-217, Vol 1, regarding equipment failure and go-around criteria.

5.27.5. Nondirectional Beacon (NDB) Procedures. The HUD alone is not sufficient for NDB approaches. A head-down display, which depicts a bearing pointer tuned to the NDB, must be used in conjunction with the HUD throughout the approach. (T-2) NDB approaches may be flown during day, night, or IMC conditions after compliance with any airfield restrictions in Global Decision Support System/ Airfield Suitability and Restrictions Report (GDSS/ASRR). Pilots should consider backing up each approach with available navaids/GPS to include loading the NDB coordinates in the FMS.

**5.28. After Beginning an En route Descent.** After starting an en route descent and the weather is reported or observed to be below approach minimums comply with AFI 11-202, Vol 3.

5.28.1. Do not continue a CAT II ILS if the weather is reported to be below CAT II minimums.

5.28.2. The PM and CSO will monitor the approach and report any deviations from prescribed procedures. (T-3)

**5.29. Cold Weather Altimeter Setting Procedures.** Apply cold weather altimeter corrections for non-tactical situations in accordance with AFI 11-202, Vol 3, and the Flight Information Handbook. For Tactical applications see [Chapter 17](#).

**5.30. Aircraft Recovery Away from Main Operating Base.** The PIC is responsible for ensuring the aircraft is turned to meet subsequent mission taskings, even when qualified maintenance specialists are unavailable.

5.30.1. The PIC is responsible for the recovery items including:

5.30.1.1. Parking and receiving.

5.30.1.2. Aircraft servicing, including Aerospace Ground Equipment usage.

5.30.1.3. Supervision of minor maintenance within local capability.

5.30.1.4. Minor configuration changes to meet mission tasking.

5.30.1.5. Securing the aircraft before entering crew rest.

5.30.1.6. Coordinating aircraft security requirements.

5.30.1.7. Documenting AFTO 781-series forms.

5.30.2. In all cases where aircrews must service the aircraft without qualified maintenance specialist assistance, comply with the appropriate maintenance TO. (T-2)

5.30.3. Aircrews are not qualified to accomplish the required ground inspections. In those instances where maintenance personnel are not available, the aircrew will enter a red dash symbol in the AFTO Form 781H, updating current status and enter a red dash symbol and a

discrepancy that reflects that the applicable maintenance inspection (i.e., preflight, thru-flight, basic post flight) is overdue. (T-3)

**5.31. Cockpit Voice Recorder (CVR).** If involved in a mishap or incident, after landing and terminating the emergency, pull the CVR power circuit breaker (Electronic Circuit Breakers (ECB) #464).

**5.32. Clearwater Rinse Facility (Birdbath).**

5.32.1. Crews should use a clear water rinse facility (birdbath) after every flight in which the aircraft is flown over saltwater below 3,000 feet, including tactical approaches. Two or more takeoffs and/or landings, including touch-and-go landings, over saltwater requires a clear water rinse after the last flight of the day per TO 1-1-691, *Cleaning and Corrosion Prevention and Control, Aerospace and Non-aerospace Equipment*.

5.32.2. If a birdbath facility is unavailable make the following annotation in the AFTO Form 781A, "aircraft subjected to salt spray, birdbath unavailable." (T-3) The following guidance will be used to maximize the effectiveness of the birdbath and to ensure safe operations.

5.32.2.1. Ensure sensors such as the radar and Electro-Optical (EO)/IR are off prior to entering the birdbath.

5.32.2.2. The APU will remain off with door closed to prevent flameout and flooding of the APU compartment. (T-2)

5.32.2.3. Set flaps to 100%. Turn off and extend landing lights.

5.32.2.4. Complete the "AFTER LANDING CHECKLIST" after rinse is completed, run engines at normal ground idle for a minimum of two minutes to aid in drying out engine nacelles.

5.32.2.5. Review local procedures for birdbath operating guidelines. Each birdbath is unique in design and function and local procedures such as direction of entry, wing tip clearance criteria, and noise abatement concerns need to be reviewed prior to use. **CAUTION:** It is possible to experience overheat indications during or immediately following the birdbath due to water intrusion in overheat warning systems.

**5.33. Support Agencies.** The PIC or a designated representative will pass significant information to support agencies, such as weather, ATC, or base operations. (T-3) The actual weather encountered should be compared to forecast weather, and this information provided to weather personnel to facilitate improved support. Debrief intelligence, when applicable.

**5.34. Crew Debriefing.** The PIC will conduct a debriefing after each mission. (T-3) The debriefing will include all applicable crew members so that common problems can be discussed and resolved. (T-3) Crew members may be excused from the debrief at the discretion of the PIC.

**5.35. Aircrew Notification Procedures.** When transiting installations, the PIC will establish a point of contact with the CCC, base operations or local airport manager. (T-3) The PIC will be notified immediately in case of incident or emergency affecting the safety or security of the aircraft. (T-3)

**5.36. Cockpit Congestion and Loose Objects.** Limit the number of persons on the flight deck to the minimum commensurate with mission requirements. At no time will this exceed nine. (T-3)

5.36.1. Store only items required for use or immediate reference in-flight on the flight deck. Additional items, to include personal bags, will be secured in the cargo compartment. (T-3) All items will be secured prior to passing the combat entry point until passing the combat exit point. (T-3)

5.36.2. Do not place any item (checklist, chart, etc.), on the center pedestal in a position that covers or hides from view any switch or light. (T-3) Do not place any item behind the power levers. (T-2)

**5.37. Dropped Objects.** During aircraft exterior visual inspections, pay particular attention to surfaces, panels, and components, which could potentially be dropped objects. If a dropped object is discovered and the mission is continued, the flight crew will: (T-3)

5.37.1. Ensure a write-up is entered in the AFTO Form 781A.

5.37.2. Notify the controlling CCC as soon as practical. Include route of flight, altitude, and weather conditions (i.e., turbulence, etc.).

**5.38. Impoundment.** If an aircraft is involved in a serious in-flight incident, the PIC should impound the aircraft immediately after landing and contact the controlling CCC for further instructions.

**5.39. Narcotics.** Crew members will ensure narcotics and other unauthorized items are not smuggled onboard the aircraft. (T-2) Maintain narcotics that are part of official medical kits in accordance with appropriate directives. (T-2)

**5.40. Due Regard Procedures.** When a unit commander authorizes a mission to be flown in international airspace over the high seas, and in-flight operational requirements conflict with International Civil Aviation Organization (ICAO) rules and procedures, the PIC may make the decision to proceed using "Due Regard" procedures in accordance with AFI 11-202, Vol 3, and FLIP General Planning.

**5.41. Sensitive Mission Operations.** Certain missions require special flight planning procedures or deceptive measures. Use of these procedures will be directed by mission operating directives, MAJCOM/CC operations orders or other tasking orders. Modification to normal procedures will be fully briefed to aircrews prior to execution of the operation. (T-3) All missions of this type requiring coordination must be approved by MAJCOM/CC or the COMAFSOF/Commander of Air Force Forces (COMAFFOR) prior to execution. (T-2) The planning agency tasked with the mission will provide the aircrew with the following information:

5.41.1. Departure procedures.

5.41.2. En route procedures to include tracks, Altitude Reservation (ALTRV), Military Assumes Responsibility for Separation of Aircraft (MARSAs), tanker rendezvous and emergency divert procedures.

5.41.3. Arrival procedures.

5.41.4. All communications requirements.

**5.42. Passenger Restrictions.** DoDI 4515.13-R, Air Transportation Eligibility, establishes criteria for passenger movement on DoD aircraft. It defines five categories of passenger travel: space-available, aeromedical evacuation, orientation, public affairs and space-required. AFI 11-401 provides further guidance on orientation and public affairs travel. Refer to these publications



directly for details not addressed in this manual. In all cases, passengers will be manifested on a DD Form 2131. (T-3) Note: Refer to AFI 11-401 for MEP policy.

5.42.1. Space-Available. Authorized passengers, processed through the passenger terminal, may occupy surplus seats on DoD aircraft after all space-required passengers have been accommodated. Required documentation is listed in DoDI 4515.13-R. Group commanders or COMAFSOF may approve space-available travel on MC-130J and C-130J aircraft after careful consideration of mission requirements and sensitivities. The following restrictions apply:

5.42.1.1. Both pilots must be fully qualified. (T-2)

5.42.1.2. Group commanders or COMAFSOF may approve AAR and HAAR/TAAR on a case-by-case basis.

5.42.1.3. All other mission events and simulated Emergency Procedures (EP) are prohibited. (T-3)

5.42.2. Aeromedical Evacuation. Defined as the movement of patients by air. Specific guidance on eligibility and documentation is contained in DoDI 4515.13-R. Commander, USTRANSCOM is the single manager for policy and procedure. Comply with the following restrictions:

5.42.2.1. Both pilots must be fully qualified. (T-2)

5.42.2.2. AAR and HAAR/TAAR may be performed if required for mission accomplishment after coordination with tasking authority.

5.42.2.3. All other mission events and simulated EPs are prohibited. (T-3)

5.42.3. Orientation. There are four categories of orientation flight (refer to AFI 11-401): incentive flights, Distinguished Visitor flights, familiarization flights, and spouse orientation flights. Document authorization by letter and DD Form 2131. Requests for approval will include the mission profile and events to be accomplished. (T-2) Comply with the following restrictions:

5.42.3.1. For spouse orientation, comply with restrictions in AFI 11-401. Additionally, AAR, HAAR/TAAR, and threat maneuvers are prohibited.

5.42.3.2. For other orientation categories, both pilots must be fully qualified. (T-2) Group commanders or COMAFSOF may approve/authorize all mission events on a case-by-case basis. Simulated EPs are prohibited. Passengers will be seated with belts fastened during threat maneuvers. (T-3)

5.42.4. Public Affairs Travel. Defined as travel in the interest of adding to the public understanding of DoD activities. AFI 11-401 contains specific details on the Air Force Public Affairs Flight Program. Document authorization by letter and manifest on DD Form 2131. Requests for approval will include the mission profile and events to be accomplished. Forward requests through public affairs channels. (T-2) Comply with the following restrictions:

5.42.4.1. Both pilots must be fully qualified. (T-2)

5.42.4.2. Simulated EPs are prohibited. (T-2)

5.42.4.3. Passengers will be seated with belts fastened during threat maneuvers. (T-3)

5.42.5. Space-required. DoDI 4515.13-R lists several categories of passengers who are authorized official travel on DoD aircraft. Apply the space-available processing, approval, and restrictions to all space-required categories with the following exceptions:

5.42.5.1. Supported Forces. A subcategory of space-required passenger defined by this instruction as US and foreign military personnel who are an integral part of the mission being performed. Approval is assumed by the mission tasking. Manifest on DD Form 2131. There are no restrictions on mission events. The PIC will ensure supported forces are briefed on the mission profile and events before flight. (T-3) Comply with the following restrictions:

5.42.5.1.1. Both pilots must be fully qualified (unless specified otherwise by AFI 11-401). (T-2)

5.42.5.1.2. Simulated EPs are prohibited. (T-2)

5.42.5.1.3. Passengers will be seated and secured during threat maneuvers.

5.42.5.2. Mission Essential Personnel. A subcategory of space-required passenger defined by AFI 11-401, MAJCOM SUP and this manual. A letter of authorization from the group commander or COMAFSOF will document local flights. Deployed squadron or mission commanders may approve squadron-assigned personnel, or maintenance personnel required for mission accomplishment. 18 Special Operations Test and Evaluation Squadron (SOTES)/CC is the approval authority for supporting forces in conjunction with test missions. When frequent local flights are necessary, commanders may issue annual authorizations by name or Air Force Specialty Code (AFSC), as appropriate. When using this option, the PIC will ensure that all restrictions in the following paragraph are complied with for each individual mission. (T-3) The PIC will ensure supporting forces are briefed on the mission profile and events before flight. (T-3) Comply with the following restrictions:

5.42.5.2.1. Both pilots must be fully qualified (unless specified otherwise by AFI 11-401). (T-2)

5.42.5.2.2. Simulated EPs are prohibited. **Exception:** EPs required for the purposes of a Functional Check Flight (FCF) are authorized.

5.42.5.2.3. Limit personnel to absolute minimum required). (T-3)

5.42.5.2.4. Passengers will be seated and secured during threat maneuvers. (T-3)

**5.43. Cargo Documentation.** Proper cargo documentation will accompany each load. (T-3)

5.43.1. The cargo manifest and DD Form 1384, *Transportation Control and Movement Document* (interpreted punch card deck or manual form), and special handling documents as applicable, will be delivered to the aircraft before departure. (T-3) The manifest will be one of the following: (T-3)

5.43.1.1. Computer printed product.

5.43.1.2. 80/80 (Offline Manifest) listing.

5.43.1.3. DD Form 1385, *Cargo Manifest*.

5.43.1.4. DD Form 2130-2 *C-130 A/B/E/H Load Plan*. This form is designed for use during exercises, wartime and contingency operations.

5.43.2. DD Form 2133, *Joint Airlift Inspection Record*, will accompany the manifest, if required.

5.43.3. Shipper's Declaration for Dangerous Goods prepared by the shipper in accordance with AFMAN 24-204, *Preparing Hazardous Materials for Military Air Shipments*, and AF Form 127, *Traffic Transfer Receipt*, will accompany the manifest, if required.

**5.44. Airlifting Hazardous Cargo Material Procedures.** The term "hazardous material" includes substances or materials that are capable of posing an unreasonable risk to health, safety, and property when transported and has been so designated by AFMAN 24-204. May also be referred to as hazardous cargo or dangerous goods. Note: For identification, listing, and rules pertaining to hazardous waste, refer to Title 40 CFR, Parts 260-265, Protection of Environment, established by the US Environmental Protection Agency. Hazardous materials are assigned hazard classes. The category of hazard assigned to a hazardous material is based on defining criteria. Hazard classes are: explosives and ammunition (Class 1), compressed gases (Class 2), flammable liquids (Class 3), flammable solids, spontaneously combustible material, and dangerous when wet material (Class 4), oxidizers and organic peroxides (Class 5), toxic materials and infectious substances (Class 6), radioactive materials (Class 7), corrosive materials (Class 8), and miscellaneous dangerous goods (Class 9).

5.44.1. Cargo Documentation. Do not accept hazardous materials unless proper documentation, certification, and identification of cargo are provided. (T-3) This includes transportation control number entered correctly on both the cargo manifest and the Shipper's Declaration for Dangerous Goods.

5.44.2. Aircrew Responsibilities.

5.44.3. As a minimum, the PIC and/or designated crew member must be briefed at the base of departure concerning onboard hazardous materials, including the following information: (T-3)

5.44.4. Proper Shipping Name (PSN), Hazard Class or Division and United Nations (UN), North American (NA), or ID number.

5.44.4.1. Quantity of each hazard class by gross weight.

5.44.4.2. The Net Explosive Weight (NEW) for Division 1.1 through 1.3 explosives.

5.44.4.3. Total net quantity of any toxic chemical ammunition or highly toxic substances.

5.44.4.4. Location on aircraft.

5.44.4.5. Passenger restrictions.

5.44.4.6. Smoking restrictions.

5.44.4.7. Special requirements, i.e., couriers, protective equipment, etc.

5.44.4.8. Cargo being carried under Department of Transportation (DOT) exemptions, Certificate of Equivalency (COE), a Competent Authority Approval (CAA) or a waiver.

5.44.4.9. If any of the above is omitted, request it before accepting cargo. Check air cargo manifest (and attached Shipper's Declarations) before signing.

5.44.5. Border Clearance and Diplomatic (DIP) Clearances. Aircrews are required to check the FCG for DIP Clearance requirements prior to departure on international flights transporting Hazardous Materials. If DIP Clearance is required, the crew will verify that clearance has been granted prior to departure. (T-3) **Note:** Generally, a different diplomatic clearance is given when hazardous cargo is being carried. Aircrews should reference the FCG or contact the Country Specific Air Liaison officer for more information. Do not assume a blanket diplomatic clearance is clearance to carry hazardous cargo.

5.44.6. Flight Plans. Flight plans will be annotated "Hazardous Cargo" when any amount of the following is transported: (T-3)

5.44.6.1. Division 1.1 through 1.3 explosives.

5.44.6.2. Toxic chemical ammunition (Compatibility Group K).

5.44.6.3. Highly toxic substances.

5.44.6.4. Division 6.2 infectious substances which require technical escorts and/or special protective equipment.

5.44.6.5. Nuclear weapons.

5.44.6.6. Class 7 Radioactive Material (Yellow III label).

5.44.6.7. All other hazardous materials, except Class 9 Miscellaneous and Other Regulated Materials-Domestic (ORM-D) when aggregate gross weight exceeds 1,000 pounds (454 kgs).

5.44.7. Departure/Arrival Notifications.

5.44.7.1. Prior to departure, verify airfield controlling agency.

5.44.7.2. Forward hazardous materials information to emergency response agencies.

5.44.7.3. Include hazardous materials information in the departure message, if required.

5.44.7.4. If Estimated Time of Arrival (ETA) is less than 1 hour, or other circumstances preclude message receipt at destination, provide hazardous information by priority telephone.

5.44.7.5. At least 30 minutes prior to ETA, check with destination to verify that hazardous material notification information, if required, was received.

5.44.7.6. If not, unless prohibited by the theater commander or FLIP planning, contact controlling agency at destination and provide as a minimum:

5.44.7.6.1. PSN.

5.44.7.6.2. Hazard class.

5.44.7.6.3. UN, NA, or ID number.

5.44.7.6.4. NEW for Class 1 (Explosives).

5.44.7.6.5. Net quantity of chemical ammunition and toxic substances.

5.44.8. Aircraft Parking.

5.44.8.1. Parking of aircraft carrying hazardous materials is the responsibility of the host airfield.

5.44.8.2. The following is provided for information only:

5.44.8.2.1. Aircraft transporting Division 1.1 and 1.2 explosives, nuclear weapons, and Hazardous Materials requiring a Special Assignment Air Mission, i.e., Toxic Chemical Ammunition, are normally parked at remote (Hot) spots.

5.44.8.2.2. Divisions 1.3/1.4 explosives may or may not require "HOT" spot parking depending on quantity of explosives.

5.44.8.2.3. Transit aircraft with explosives, when cargo is not handled, may be parked at isolated locations other than "HOT" spots.

5.44.8.2.4. Other hazardous materials normally do not require remote or isolated parking.

5.44.8.2.5. Military installations are responsible for proper placarding of aircraft.

#### **5.45. Hazardous Medical Equipment/Special Cargo.**

5.45.1. Nonstandard equipment possessed by medical facilities that use air evacuation services should be regarded as potentially hazardous. Two types of equipment are of major concern:

5.45.1.1. Electronic medical equipment produces Electro-magnetic Interference which is commonly beyond the limits specified by MIL Standard (STD) 461A and 462, and therefore can interfere with aircraft communication and navigational equipment.

5.45.1.2. Therapeutic oxygen systems present an increased hazard of fire or explosion. A potential hazard is the inadvertent disruption of the cylinder neck, manifold, or regulator resulting in explosion and propulsion of the container or accessories.

5.45.2. For nonstandard electronic medical equipment, take the following precautions:

5.45.2.1. Medical personnel must inform the PIC when nonstandard electronic medical equipment is brought on board the aircraft. (T-3)

5.45.2.2. The PIC must be informed of the anticipated period of use of the equipment during the mission. (T-3)

5.45.2.3. The PIC must be alert for any interference with aircraft communications or navigation equipment during periods of use of this equipment. (T-3)

5.45.2.4. When continuous use of the equipment is required throughout the duration of the mission, flight must be restricted to VFR conditions. Furthermore, exercise additional caution on night VFR missions to ensure there are no adverse effects on navigational equipment. (T-3)

5.45.3. For nonstandard oxygen equipment, take the following precautions:

5.45.3.1. All compressed oxygen equipment with exposed, unprotected cylinder neck, manifold, or regulator must be completely secured from all movement in its longitudinal and lateral axes. (T-3)

5.45.3.2. Medical personnel must continually monitor the operation of the equipment to detect possible malfunction during exposure to altitude. (T-3)

5.45.4. Mission Capability/Awaiting Parts (MICAP), Very Important Person, sensitive cargo, courier materials, and registered mail moving within the normal airlift system are receipted at the on/offload stations using the air cargo manifest. For unit moves operated in accordance with Defense Transportation Regulation (DTR), Part III, Mobility, classified or sensitive cargo movement is normally manifested utilizing the DD Form 2130-2, Cargo Manifest, or similar automated product (such as Computer Aided Load Manifesting or Automated Air Load Planning System), and will normally be accompanied by a unit courier. However, if classified/sensitive unit cargo is offered without an accompanying courier, the DD Form 1907, Signature and Tally Record, must be used.

5.45.4.1. Defense Courier Service (DCS) couriers coordinating with the PIC are authorized to designate officer or enlisted, (E-5 and above) crew members on military aircraft as couriers to escort and safeguard courier material when other qualified personnel are not available. Qualified passengers, if carried, are designated before designating crew members. The following restrictions apply:

5.45.4.1.1. Primary crew members will not be designated couriers without the consent of the PIC. (T-3)

5.45.4.1.2. Crew members on aircraft scheduled to make an extended en route stop at a location where DCS couriers cannot provide en route support will not be designated as couriers. (T-3)

5.45.4.2. During stops at en route locations supported by DCS stations, DCS couriers are required to meet designated couriers, guard and protect the material.

5.45.4.2.1. During unscheduled en route stops crew members may place courier material in temporary custody of the following agencies in descending order of priority.

5.45.4.2.1.1. DCS courier.

5.45.4.2.1.2. TOP SECRET control officer of the US armed forces.

5.45.4.2.1.3. US Department of State Diplomatic Courier.

5.45.4.2.1.4. US Department of State activity.

5.45.4.2.1.5. US military guards.

5.45.4.2.1.6. US DoD civilian guards.

5.45.4.3. If unable to follow the itinerary to the destination of the courier material, or material is lost, stolen, or otherwise compromised, report circumstances to the nearest Defense Courier Station and notify the local US military commander or US Government activity.

5.45.4.4. Life or death urgency shipments consist of biological or other medical supplies of such urgency that human life is dependent upon immediate receipt. Shipments will be manifested separately and the manifest annotated with the words LIFE OR DEATH URGENCY. All shipments will be handled on a hand-to-hand receipt basis, using either the air cargo manifest or the DD Form 1907, for unit moves. (T-3) The PIC will be briefed on the urgency of the shipment and be made the custodian during flight. (T-3)

#### **5.46. Border Clearance.**

#### 5.46.1. Normal Operations:

5.46.1.1. Border Clearance Responsibility. The responsibility will be IAW the applicable Foreign Clearance Guide and AFI 24-203, *Preparation and Movement of Air Force Cargo*.

5.46.1.2. Pilot In Command Responsibility. Border clearance is the responsibility of the PIC, although many of the duties have been assigned to ground personnel and to the loadmaster. The PIC will ensure all requirements in the Foreign Clearance Guide are met, and all passengers are briefed on special procedures. (T-3)

5.46.1.3. En route to the US, the loadmaster has distributed personal customs declarations to all passengers and crew members; has briefed passengers and crew members on customs regulations; and has prepared and compiled necessary border clearance forms for the PIC's signature.

5.46.1.4. En route to the US, the base of intended landing is notified of any change in ETA, to ensure border clearance is accomplished as soon as possible after landing.

5.46.1.5. A Permit to Proceed is obtained when the mission requires an aircraft, which has landed in the US for customs clearance, to proceed to another US base to obtain border clearance. The permit delays customs inspection of cargo, passengers, and crew until arrival at the offload station, saving intermediate offloading and reloading normally required for customs inspection. The Permit to Proceed is valid only to the airport of next landing, where the border clearance must be completed, or a new permit obtained. Do not make intermediate stops unless required by an emergency situation, or directed by MAJCOM. (T-3)

5.46.1.6. When an aircraft lands for a US border clearance, a US Customs representative normally meets the aircraft to obtain the required documents. Do not deplane passengers or crew members, except a scanner, unless necessary for safety. Do not unload until approved by customs and agriculture personnel or their designated representatives. This procedure applies to the initial landing in the US and all subsequent landings until crew, passengers and cargo complete final border clearance.

#### 5.46.2. Exercise and Contingency Operations.

5.46.2.1. General. Certain missions, which do not transit normal ports of entry or exit, require special procedures to expedite compliance with customs, public health, immigration and agricultural requirements. A joint memorandum of understanding establishes procedures and waivers.

5.46.2.2. Implementation. Traffic and border clearing agencies implement all or part of the agreement as necessary for each operation. Inspection and clearance may be accomplished at the CONUS onload or offload base instead of the normal port of entry, or at the foreign onload or offload base.

### 5.47. Customs Procedures.

5.47.1. Outbound: No requirements. Filing of a Customs Form (CBP) 7507, *General Declaration (Outward/Inward)*, is waived.

5.47.2. Inbound. Prepare one copy of the following documents before arrival.

5.47.2.1. CBP Form 7507 (passenger list not required).

5.47.2.2. Cargo manifest.

5.47.2.3. CBP Form 6059B, *Customs Declaration* for each person on the aircraft.

#### **5.48. Immigration Procedures.**

5.48.1. Outbound. No requirements.

5.48.2. Inbound. Submit the following to the Immigration inspector.

5.48.2.1. One copy of CBP Form 7507.

#### **5.49. Customs, Immigration and Agricultural Inspections.**

5.49.1. Obtain Customs, Agriculture, and Public Health clearance, as required, prior to opening any doors, hatches, or windows, other than the crew entrance door, or enplaning and deplaning personnel.

5.49.2. Proceed directly from the aircraft to Customs, Immigration or Agricultural inspection for processing when required by the inspector.

5.49.3. US military aircraft are sovereign territory. When cleared to overfly or land in foreign territory, it is US policy to assert that military aircraft are entitled to the privileges and immunities which customarily are accorded to warships. These privileges and immunities include, in the absence of stipulations to the contrary, exemption from duties and taxation, immunity from search, seizure, and inspections (including customs and safety inspections); or other exercise of jurisdiction by the host nation over the aircraft, personnel, equipment, or cargo on board. The PIC will not authorize search, seizure, inspection or similar exercises of jurisdiction enumerated above by foreign authorities except by direction of HQ AF or the American Embassy in the country concerned.

5.49.3.1. The PIC will not permit the inspection of their aircraft by officials of any foreign government. (T-3) If requested to submit to these actions, the PIC and crew will deny access to the aircraft and seek aid from the senior AF representative in the US Embassy or Consulate within the host nation. (T-3) Customs or other officials will be informed of the above policy and requested to confirm their request through their own government and with US Department of State representatives. If necessary, the crew will seal the aircraft, the crew entered into crew rest, and departure intentions will be canceled until resolution of the matter by the appropriate authority. (T-3) Inform C2 authorities by the fastest available means should this situation occur. (T-3)

5.49.3.2. When confronted with a search request by foreign authorities, aircrews should consider the following procedures:

5.49.3.2.1. In most cases, search attempts may be stopped by a statement to the foreign officials that the aircraft is sovereign and not subject to search without consent of HQ AF or the chief of mission in the country concerned. This should be clearly conveyed in a polite manner so as not to offend foreign authorities that may honestly, but mistakenly, believe they have authority to search AF aircraft.

5.49.3.2.2. If foreign authorities insist on conducting a search, the PIC must negotiate to delay the search until contact is made with HQ AF or the appropriate embassy. The PIC should unequivocally state that they have no authority to consent to the search and that they must relay the host nation request to these agencies for decision. The PIC



should then notify these agencies of the request by the most expeditious means available. Thereafter, the PIC should follow instructions provided by the appropriate embassy and HQ AF.

5.49.3.2.3. If foreign officials refuse to desist in their search request, the PIC should indicate that they would prefer to fly the aircraft elsewhere (provided fuel and mechanical considerations permit a safe departure) and request permission to do so.

5.49.3.2.4. If permission is refused and the foreign authorities insist on forcing their way on board an aircraft, the PIC should state that they protest the course of action being pursued and that they intend to notify both the appropriate American Embassy and HQ AF of the foreign action. The PIC should then allow the foreign agents onboard the aircraft, without physical resistance, and thereafter report the incident to HQ AF and appropriate embassy, as soon as possible.

5.49.3.3. In all instances, specific instructions may be briefed because of sensitive cargo or equipment. These instructions and applicable provisions of classified supplements to the FCG should be followed, where applicable.

#### **5.50. Military Customs Preclearance Inspection Program:**

5.50.1. The military customs program outlined in DTR 4500.9-R Part 5, Chapter 506, *DoD Preclearance Program Customs and Agricultural Inspections* was developed to assist the DoD and other US Government agencies in the control of narcotics, contraband, and prohibited agricultural products, and to expedite entry of DoD personnel and material into the customs territory of the United States.

5.50.2. Military Customs Inspectors will accomplish this inspection immediately prior to departure and may conduct more than one preclearance inspection on CONUS-bound aircraft. When security considerations necessitate deviation from this policy, mission planners must coordinate with the appropriate agency to ensure the mission is not jeopardized. (T-3)

#### **5.51. Insect and Pest Control (Aircraft Spraying).**

5.51.1. The PIC will ensure required spraying is accomplished (if applicable), and certify the spraying on required forms. (T-3)

5.51.2. Aerosol normally is dispersed at a flow rate of 10 seconds per 1,000 cubic feet. Direct the nozzle toward the ceiling of the compartment or space being sprayed. Do not spray any plastic surface or allow the spray to wet it. (T-3)

5.51.3. Spray spaces inaccessible from within the aircraft after completely loading fuel, baggage, cargo, and passengers, including baggage compartments, wheel wells, and other similar spaces.

5.51.4. Spray the cabin, cockpit, and other spaces accessible from within the aircraft after the crew is on board and after closing all doors, windows, hatches, and ventilation openings. **CAUTION:** If the insecticide label directs disembarkation after use, spray prior to boarding crew or passengers. Close all doors and hatches for 10 minutes after dispensing and ventilate for 15 minutes before allowing anyone on board.

5.51.5. When spraying is required, use insecticide, aerosol d-phenothrin-2 percent, National Stock Number (NSN) 6840-01-067-6674 (or equivalent), to spray the aircraft. Wear leather

or Nomex gloves while spraying. Spray for 50 seconds unless longer periods are specified for the country being transited.

5.51.6. When seeing any insect or rodent infestation of the aircraft in-flight, notify the destination CCC, base operations or airport manager of the situation before landing so the proper authorities can meet the aircraft.

5.51.7. Upon arrival, do not open cargo doors or hatches except to enplane officials inspecting the aircraft for insect or rodent infestation. (T-3) Do not onload or offload until the inspection is satisfactorily completed. (T-3) This procedure may be altered to satisfy mission or local requirements, as arranged by the base air terminal manager.

## Chapter 6

### AIRLAND OPERATIONS

**6.1. Aircraft Maximum Gross Weight.** Aircraft maximum gross weight is 164,000 pounds. Waiver authority for operations above 164,000 pounds up to and not to exceed 171,000 pounds is the OG/CC. MAJCOM/A3 or COMAFSOF is the waiver authority for gross weights above 171,000 pounds. The maximum waivable gross weight is 175,000 pounds. Operations above 164,000 pounds require an AFTO Form 781A entry with the actual gross weight at which the aircraft was operated.

**6.2. Checklists.** Aircrew must be familiar with notes, warnings, and cautions without direct reference to TO. (T-3)

6.2.1. The only pages (or inserts) authorized in checklist binders are C-130 series TO aircrew checklists, MAJCOM approved checklists, briefing guides, and unit approved information guides. Units may construct locally approved in-flight guides using AF Form 4124, *Flight Crew Information Guide*.

6.2.2. Write in changes and personal notes must be current and annotated in accordance with AFI 11-215, *USAF Flight Manuals Program (FMP)*. (T-3)

**6.3. Duty Station.** One of the pilots may be out of their seat for brief periods to meet physiological needs. With both pilots in their seats, the PIC may authorize rest periods for one pilot occupying a primary duty station in accordance with Controlled Cockpit Rest guidance in AFI 11-202, Vol 3. All other crew positions are authorized rest periods with approval from the PIC and in accordance with AFI 11-202, Vol 3. Only one pilot may be absent from their duty station at a time. All aircrew members will notify the PIC prior to departing assigned primary duty station. (T-3)

**6.4. Flight Deck Entry.** The PIC may authorize passengers on the flight deck during takeoff, landing, and critical phases of flight, provided they have a designated seat.

**6.5. Takeoff and Landing.**

6.5.1. A certified Aircraft Commander (AC) will occupy the left seat during all takeoffs, approaches, and landings. (T-2) A certified Instructor Pilot (IP) may accomplish any task from either seat.

6.5.2. The left seat pilot will land during aircraft emergencies. (T-2) A certified IP may takeoff or land from either seat under any condition.

6.5.3. A Mission Pilot (MP), Mission Copilot (MC), or First Pilot (FP) during AC upgrade with an IP/Evaluator Pilot (EP) in the right seat, may takeoff/land from the left seat. (T-2)

6.5.4. An MP or FP may take off and land from either seat.

6.5.5. MCs and FPs will not perform takeoffs or landings from the right seat under the following conditions: (T-2)

6.5.5.1. During formation departures and recoveries.

6.5.5.2. During maximum effort or substandard airfield operations.

- 6.5.5.2.1. Pilots in “Instructor Pilot” upgrade training may takeoff and land from the right seat under the supervision of an Instructor Pilot during formation departures and recoveries and during maximum effort or substandard airfield operations.
- 6.5.5.3. During missions operating in areas of hostile activity. For units operating in defined combat zones, Sq/CC or deployed equivalent may authorize landings from the right seat at specific airfields. **Exception:** Main operating bases with an Instrument Approach do not require approval.
- 6.5.5.4. At airfields that require any waiver approval. **Exception:** Non-Department of Defense (DoD) approach waivers.
- 6.5.5.5. At certification airfields specified in Air Mobility Command Airfield Suitability and Restrictions Report (ASRR) via GDSS.
- 6.5.6. PICs who possess less than 50 hours in command in C-130J variant aircraft since initial aircraft commander certification will make all takeoffs and landings when the right seat is occupied by an MC or FP. (T-3)
- 6.5.7. Current and qualified MCs may accomplish Night Vision Goggle (NVG) takeoffs and landings (non-maximum effort) from the right seat provided the pilot occupying the left seat in NVG airland current and qualified.

## 6.6. Landing Gear and Flap Operation.

- 6.6.1. The PM will operate the landing gear, landing, and taxi lights. (T-3) Actuate the landing gear only after the command of the PF the aircraft. Prior to actuation of the landing gear, the PM will acknowledge the command by repeating it. (T-3)
- 6.6.2. PM operate the flaps only after the command of the PF. Prior to operating the flaps, acknowledge the PF’s command by repeating it.

## 6.7. Seat Belts. Crew members occupying the Pilot (P) and CP positions will have seat belts fastened from engine start through shutdown, except as outlined in [Paragraph 6.3](#) and the following: (T-3)

- 6.7.1. All occupants will be seated with seat belts fastened during taxi, takeoffs, and landings. (T-3) **Exception:** Evaluators, Instructors, Mission Commanders, crew members performing scanner duties, outside observers during taxi, LMs and medical personnel performing required duties; however, those individuals will have a designated seat (spot for combat loading procedures) and required restraint available.
- 6.7.2. Provide a safety belt for all occupants over 2 years of age. Occupants will fasten seat belts securely when turbulence is encountered or anticipated, or in areas of forecast clear air turbulence. (T-3)
- 6.7.3. Floor loading is authorized to support dedicated unconventional forces and foreign counterparts during operations, exercises and training. This procedure will not be used in lieu of providing normal seating when available. (T-3) **Exception:** Group commander (COMAFSOF for contingency operations) may authorize Rapid Infil/Exfil procedures and floor loading with non-SOF personnel.

**6.8. Aircraft Lighting.** For single ship, non-tactical operations refer to AFI 11-202, Vol 3 MAJCOM SUP. Use landing lights at night in unlighted areas. (T-2) Use taxi lights in-flight any time the landing gear is extended unless reflections cause pilot distractions. (T-2)

6.8.1. NVG operations may dictate that external lights are turned off or Infrared (IR) lenses used. Conduct training operations with reduced or no external lighting within the confines of designated Restricted or Warning areas or host nation approved areas IAW AFI 11-202, Vol 3 MAJCOM SUP. (T-2) Single ship aircraft will display normal aircraft lighting outside Special Use Airspace (SUA). (T-2) In standard formation, all aircraft except the last in the formation will display formation lights with brightness set and IR anti-collision lights as required. (T-2) The last aircraft in the formation will display lights in accordance with AFI 11-202, Vol 3. (T-2) **Note:** Formations may vary lighting as necessary provided adequate visual identification of the formation is maintained.

**6.9. Advisory/Required Calls.** The PF will announce changes to the level of automation, flight director and autopilot mode section, and mode transition, (e.g., “Autopilot engaged”, “Altitude hold,” “Auto-throttles,” “Nav-Capture,” etc.), and/or when circumstances require deviating from normal procedures. (T-3) **Table 6.1** through **Table 6.4** depict mandatory calls for takeoff, climb out and descent, non-precision and precision approaches.

**Table 6.1. Takeoff.**

PHASE OF FLIGHT	PF CALL	PM RESPONSE
Takeoff – prior to Refusal Speed		“Reject” <sup>1</sup>
At Refusal Speed		“Go” <sup>2</sup>
At Rotation Speed		“Rotate” <sup>2</sup>
<p><b>Note 1:</b> Prior to refusal speed, any crew member noting a safety of flight condition/malfunction will state “reject” and give a brief description of the malfunction.</p> <p><b>Note 2:</b> If rotation speed and refusal speed are equal then state “rotate.”</p>		

**Table 6.2. Climb Out and Descent.**

PHASE OF FLIGHT	PF CALL	PM RESPONSE
Climb Out - Transition Altitude	State Altimeter	State Altimeter
Climb Out - 1,000 below assigned altitude Flight Level (FL)	“Passing # Feet for # Feet”	“Checks”
Descent - Transition Level	State Altimeter <sup>1</sup>	State Altimeter <sup>1</sup>
Descent - 1,000 above assigned altitude/FL, initial approach fix, or holding altitude	“Passing # Feet for # Feet”	“Checks”
<p><b>Note 1.</b> All crew positions who can change the altimeter setting will state the new setting.</p>		

**Table 6.3. Non-Precision Approach.**

PHASE OF FLIGHT	PF RESPONSE	PM CALL
-----------------	-------------	---------

100 above Final Approach Fix (FAF) altitude, step-down altitude(s), and Minimum Descent Altitude (MDA)		“100 Above”
At MDA		“Minimums”
Runway environment in sight	State “Landing” or “Going Around”	“Runway In Sight”
At MAP	State “Landing” or “Going Around”	“Missed Approach Point”
Any condition requiring a go-around	“Going Around”	“Go-Around”

**Table 6.4. Precision Approach.**

PHASE OF FLIGHT	PM CALL	PF RESPONSE
100 feet above FAF/Glide Slope Intercept (GSI) altitude and Decision Height (DH)	“100 Above”	
At DH with:		
Runway environment in sight		“Landing”
Approach lights in sight (CAT 1 ILS)		“Continuing” <sup>1</sup>
Neither in sight		“Going Around”
Any condition requiring a go-around	“Go-around”	“Going Around”
<p><b>Note 1:</b> With weather at CAT 1 minimums on a CAT 1 ILS, the pilot may only see the initial portion of the Approach Lighting System (ALS). The pilot may continue to 100 Height Above Touchdown (HAT) but may not descend below 100 feet above touchdown zone elevation using the ALS as a reference unless the red termination bars or the red side row bars are also visible and identifiable.</p>		

#### 6.9.1. Deviations:

6.9.1.1. The PM will inform the PF when heading or airspeed deviations are observed, or when altitude is more than 100 feet from the desired and no attempt is being made to correct the deviation. (T-3)

6.9.1.2. Any crew member seeing a deviation of 200 feet altitude or 10 knots in airspeed, or a potential terrain or obstruction problem, will immediately notify the PF. (T-3) Deviations from prescribed procedures will also be announced. (T-3)

**6.10. Wind Limitations. Maximum crosswind limits are in accordance with aircraft TO limitations. Remain within the “Recommended” or “Caution” areas of the crosswind charts for normal takeoffs and landings. All maximum effort operations and simulated engine out**

landings must fall within the “Recommended” area unless otherwise approved by the Group Commander/COMAFSOF (for contingency operations).

**6.11. Runway Condition Reading (RCR) and Runway Surface Condition (RSC).** The performance charts used to determine braking action are based on concrete runways. The runway surface should be considered wet when water on the runway causes a reflective glare. The RCR values for the following runway surfaces in [Table 6.5](#) are estimates based on operational experience and should be used only as a guide.

**Table 6.5. RCR Values.**

TYPE SURFACE	RCR (DRY)	RCR (WET)
Asphalt	23	12
Aluminum Matting	20	10
M8A1/Pierced Steel Plank (PSP) With Antiskid	20	8
M8A1/PSP Without Antiskid	13	3
Clay/Crushed Rock/Coral	16	5

6.11.1. Limit MC-130J operations into and out of slush or water covered runways to a covering of one inch. This number is based on performance charts where an RSC of 10 is equal to one inch of slush or water. Performance data where more than one inch of slush or water is present may not be accurate.

**6.12. Wake Turbulence Avoidance.** Adhere to aircraft wake turbulence avoidance and separation criteria contained in DoD FLIP (General Planning [Chapter 5](#)).

**6.13. Landing Zone (LZ) Markings.** LZ markings may vary depending upon the supporting agency (refer to AFI 13-217, *Drop Zone and Landing Zone Operations*). The markings to be used must be firmly established during mission planning and included in the aircrew briefing. (T-3)

**6.14. Aircraft Rescue Fire-Fighting Requirements (ARFF).** ARFF requirements at non-AF active flying bases are as follows:

6.14.1. Up to four takeoffs and landings within seven consecutive days may be accomplished at a LZ or airfield without ARFF. This is an airfield restriction. Each unit should track totals at airfields under their control. If totals are not tracked at airfields owned/controlled by other agencies, Wing/Group current operations will track to ensure the restriction is not exceeded for assigned aircraft. (T-3)

6.14.2. For more frequent operations at an LZ or airfield, refer to AFPAM 32-2004, *Aircraft Fire Protection for Exercises and Contingency Response Operations*, to calculate ARFF requirements. **Note:** Non-AF ARFF vehicles may be used if the agent and pumping capabilities are equivalent.

6.14.3. Waivers to the ARFF requirements will be considered on a case-by-case basis. Required information for waiver request can be found in AFPAM 32-2004.

**6.15. Crew Resource Management (CRM).** CRM is a critical part of the successful employment of the MC-130J. Due to the MC-130J architecture, aircrew should ensure they

coordinate any manipulation of the CNI-MU, Radar, TAWS, fuel panel, etc. The PIC will ensure CRM is covered during the aircrew briefing. (T-3)

6.15.1. "Time Out" is the common assertive statement for use by all crew members. The use of "Time Out" will: (T-3)

6.15.1.1. Provide a clear warning sign of a deviation or loss of situational awareness.

6.15.1.2. Provide an opportunity to break the error chain before a mishap occurs.

6.15.1.3. Notify all crew members when someone sees the aircraft or crew departing from established guidelines, the briefed scenario or that someone is simply uncomfortable with the developing conditions.

6.15.2. As soon as possible after a "Time Out" has been called, the aircrew will take the following actions: (T-3)

6.15.2.1. Safety permitting, stabilize the aircraft and ensure terrain clearance.

6.15.2.2. The initiating crew member will voice their concerns to the crew.

6.15.2.3. The PIC will provide all other crew members with the opportunity to voice inputs relative to the stated concerns.

6.15.2.4. After considering all inputs, the PIC will direct the aircrew to continue the current course of action or direct a new course of action.

6.15.3. ACAWS crew coordination. Preface all ACAWS messages by stating "ADVISORY", "CAUTION", or "WARNING" followed by reading the displayed message verbatim prior to silencing the audio alert.

6.15.4. Fuel Panel. The fuel panel is considered a "verification panel." The PM/Loadmaster (LM)/CSO should advise the PF before operating the panel (i.e., priming, cross-feeding, tank-to-engine, transferring, nonstandard configurations, and dumping). After completing the task, the PM should verify the panel is set correctly.

6.15.5. Critical Action Coordination.

6.15.5.1. Flight critical/irreversible actions should always be confirmed by two crew members. These actions include, but are not limited to, pulling the engine fire handle, placing the engine start switch to stop, moving a propeller control switch to feather, discharging agent, dumping fuel, and pulling ECBs. The crew member performing the action points to the affected switch/handle and verbally seeks confirmation from a second crew member (i.e., "CONFIRM NUMBER ONE"). The crew member confirming the action looks at the affected switch/handle and acknowledges (i.e., "NUMBER ONE CONFIRMED").

6.15.5.2. Once the fire handle is pulled, the ACAWS messages indicating the shutdown condition/situation may disappear. Verifying and verbally confirming associated ACAWS messages prior to engine shutdown will assist the aircrew to determine if the engine can be restarted or if a greater emergency arises.

**6.16. Automation.** Aircraft automation will not command crew actions. (T-2) The automated systems will recommend/perform actions and the crew will determine/verify the proper course of action. (T-2)



6.16.1. The PF will determine the most desirable level of automation for a given situation.

6.16.2. If the AFCS/Flight Director provides unexpected commands to the flight controls, the PF will revert to lower levels of automation or manual flight as necessary before attempting to resolve system problems. (T-3)

6.16.3. Crews will follow the guidance below, except for cruise flight (above 3,000 AGL): (T-3)

6.16.3.1. The PF will fly the aircraft and maintain a dedicated heads-up lookout. (T-3) If the PF intends to be heads-down, aircraft control shall be transferred to the PM, who will remain head-up. (T-3) Head down time does not include momentary scanning/manipulation of the CNI-MU, HDDs and panels.

6.16.3.2. Any crew member that observes both pilots head-down at the same time shall alert the PF. (T-3)

6.16.3.3. If the PM must divert attention away from normal clearing and monitoring duties for an extended period of time, the PM will state “Heads-Down.” (T-3) The PF will verbally acknowledge this call. (T-3) The PM will verbalize “Heads-Up” after completion of duties. (T-3) The PF will then update the PM on current status as required. (T-3)

6.16.4. A closed loop system of entering data and verifying the correct data is entered before allowing the aircraft automation to perform a function is critically important. Regardless of who initiates the action, the other pilot must verify the data and both pilots will monitor the aircraft for the appropriate response. (T-3)

6.16.4.1. **Table 6.6** and **Table 6.7** provide standard actions for both pilots during Automated and Manual flight.

6.16.4.2. Automated Flight is defined as the autopilot fully engaged and coupled to the Flight director. Use auto-throttles as desired. **CAUTION:** If the auto-throttles are disengaged for sustained descents during automatic flight, it is possible that Altitude Capture may occur with the power levers at or near Flight Idle and result in an approach to stall condition.

6.16.5. Manual Flight is defined as the PF providing manual input to the flight controls or autopilot. Use auto-throttles as desired.

**Table 6.6. Automated Flight.**

REF/MODE PANEL	PF	PM
Reference Settings <sup>1</sup> (HP, RAD, ALT, IAS, FPA, MINS)	Set as required	Verify Settings
Mode Selections (ALT, NAV, HDG, APPR, IAS, VS)	Select desired mode & Announce mode status	Verify & Acknowledge
<b>LATERAL FLIGHT</b>		
Direct To/Intercept Course To/Route Modification <sup>2</sup>	Verify route modification & Direct the PM to execute	Modify route as directed & execute when directed

Radar Vector/Heading Change	Set the heading reference & State setting	Verify & Acknowledge
<b>VERTICAL FLIGHT</b>		
Climb/Descent Clearance	Verify & Acknowledge	Set new FL/altitude reference
<b>Notes:</b>		
1. For arrival/approach planning, the PF may transfer aircraft control to the PM and set all reference settings as required for the planned approach.		
2. CSO can perform PM duties for lateral flight.		

**Table 6.7. Manual Flight.**

REF/MODE PANEL	PF	PM
Reference Settings <sup>1</sup> (HP, RAD, ALT, IAS, FPA, MINS)	Direct PM to set (if required) Verify settings	Set as directed by PF
Mode Selections (ALT, NAV, HDG, APPR, IAS, VS)	Select desired mode & Announce mode status	Verify & Acknowledge
<b>LATERAL FLIGHT</b>		
Direct To/Intercept Course To/Route Modification <sup>2</sup>	Verify route modification Direct the PM to execute	Modify route as directed Execute when directed
Radar Vector/Heading Change	Verify & Acknowledge	Set heading reference & State setting
<b>VERTICAL FLIGHT</b>		
Climb/Descent Clearance	Verify & Acknowledge	Set new FL/altitude reference
<b>Notes:</b>		
1. For arrival/approach planning, the PF may transfer aircraft control to the PM and set all reference settings as required for the planned approach.		
2. CSO can perform PM duties for lateral flight.		

### 6.17. Ground Collision Avoidance System (GCAS)/Terrain Awareness and Warning System (TAWS).

6.17.1. When a GCAS TERRAIN or TAWS TERRAIN/OBSTACLE AHEAD alert occurs and terrain/obstacle clearance cannot be assured visually, immediately change the flight path (within 3 to 5 seconds) by initiating a takeoff power climb. Continue the climb until a safe altitude is reached or until exiting the alert envelope. With terrain and obstacles clearly in sight, the PF will call terrain/obstacle in sight, state intentions, and visually remain clear of terrain/obstacles. If the situation degrades and a GCAS PULL UP or TAWS TERRAIN/OBSTACLE PULL UP alert occurs, immediately execute the Wind Shear/GCAS/TAWS alert recovery in the flight manual. (T-2) **WARNING:** Do not delay pull-up for diagnosis of the low-altitude warning (within 3 to 5 seconds) by initiating a takeoff power climb.

6.17.2. In TACTICAL mode, several GCAS alert envelopes are modified to allow for maneuvering in close proximity to terrain. Normally, this mode is most suitable for modified contour flight and VFR low-altitude arrivals but, at the PIC discretion, may be used for any tactical operation.

## 6.18. Radar Altimeter.

### 6.18.1. Instrument Approaches.

#### 6.18.1.1. Precision Approaches.

6.18.1.1.1. Set RADALT reference to HAT minus 50 feet.

6.18.1.1.2. CAT II ILS. Set published Radar Altimeter minimums. **Exception:** When performing CAT II ILS procedures on a CAT I ILS for training/evaluations, set RADALT to published HAT.

6.18.1.2. Non-Precision Approaches. Setting the RADALT as prescribed below is meant to adequately alert the crew to an unsafe terrain clearance condition (Altitude-Altitude) in the absence of a Minimums-Minimums alert. Setting the RADALT to a higher setting than prescribed may result in premature/unexpected Altitude-Altitude advisories and prevent the GCAS Minimums alert.

6.18.1.2.1. Straight-In Approaches. Normally set RADALT reference to 250 feet (minimum setting).

6.18.1.2.2. Circling Approaches. Normally set RADALT reference to 300 feet (minimum setting).

6.18.1.3. When established on a published approach in IMC, or at night when terrain clearance cannot be assured, and an Altitude-Altitude special alert is heard, initiate an immediate go around. Once terrain clearance is confirmed, resume normal operations. In day VMC, the aircrew will evaluate the alert and determine the appropriate course of action (continue the approach or go-around). (T-3)

**6.19. Runway and Taxiway Requirements.** Use normal takeoff and landing procedures whenever practical. For mission accomplishment, if approach end overruns are available and stressed or authorized for normal operations, they may be used to increase the runway available for takeoff. All speeds and distances will be computed “without nose wheel steering.” Minimum runway width is 60 feet or 19 meters. Minimum taxiway width is 30 feet or 9 meters.

6.19.1. Use of wheel brakes. Any time wheel brakes are used on landing rollout greater than that defined in the Dash 1 as a “partial brake landing” for with or without carbon brakes, the PIC will ensure the BRAKE COOLING CHARTS (TO 1C-130(M)J-1-1) time constraints are complied with. Brake cooling times may be disregarded if the runway available is equal to or greater than Critical Field Length (CFL)/ Adjusted Minimum Field Length Maximum Effort Takeoff (AMFLMETO)/Minimum Field Length Maximum Effort Takeoff (MFLMETO) using an RCR of 5. For operational missions, the squadron/mission commander may waive both the brake cooling times and CFL/AMFLMETO/MFLMETO.

6.19.2. NVG Operations: **WARNING:** On blacked-out runways, a go-around point will be identified to all crew members prior to execution. (T-3)

6.19.3. Normal Operations (Non-Training):

6.19.3.1. Takeoff. Minimum runway length is critical field length. Normal Takeoffs shall not be made when refusal speed is less than ground minimum control speed ( $V_{mcg}$ ). (T-3) In this condition the PIC will either: (T-3)

6.19.3.1.1. Download cargo or fuel.

6.19.3.1.2. Wait until weather conditions improve.

6.19.3.1.3. Use maximum effort procedures.

6.19.3.2. Landing. The minimum runway required for normal landings is the charted landing distance over 50 foot obstacle with outboard engines in high speed ground idle and inboard engines in max reverse (2OB HGI; 2IB REV in the TO 1C-130(M)J-1-1, *Performance Manual*), and maximum anti-skid braking.

6.19.3.2.1. If runway length available for landing is less than required by the previous criteria, crews may use landing ground roll plus 1,500 feet when approved by the squadron commander. In this case, ensure the landing touchdown is in the first 500 feet of the runway.

#### 6.19.4. Short Field Operations:

6.19.4.1. Use of non-hard surfaced runways or taxiways requires Squadron Commander or Squadron Operations Officer approval (T-2). Coordinate with the Aircraft Maintenance Unit to prepare aircraft for Unimproved Runway Landing (URL) operations (T-2). Units may list approved locations in [Chapter 10](#).

6.19.4.2. Runway length. Max effort qualified Aircraft Commanders are authorized to use MFLMETO when approved by the squadron commander. Aircrew should use AMFLMETO when runway is available.

6.19.4.3. Takeoff and Obstacle Clearance Speeds: When obstacles are a factor, use maximum effort takeoff speed ( $V_{meto}$ ) and climb out at maximum effort obstacle clearance speed. When obstacles are not a factor, use Adjusted Max Effort Rotation Speed (AMAX) whenever possible. **WARNING:** Aircraft performance and obstacle clearance is based on obtaining and then maintaining obstacle clearance speed as quickly as possible. Aircraft performance below obstacle clearance speed may not allow safe clearance of obstacles.

6.19.4.4. Landing. Minimum runway length is ground roll plus 500 feet. If the zone is unmarked, minimum runway length is ground roll plus 1,000 feet. Group Commanders (COMAFSOF for contingency operations) may approve unmarked 500 foot zones.

6.19.4.4.1. Always compute landing performance with 2 engines in reverse, 2 engines in ground idle, and max antiskid braking. Group Commanders (COMAFSOF for contingency operations) may approve the use of all 4 in reverse.

**Table 6.8. Normal Operations and Maximum Effort Operations.**

Type of Maneuver/Restriction	Runway Length
Min Runway Length (Training Ops) <sup>(1)</sup>	The greater of: 3,000 feet OR

	(1) Takeoff: AMFLMETO (2) Landing: Landing Ground Roll + 500 feet <sup>(4) (5) (6) (7)</sup>
Normal/Max Effort Takeoff	CFL <sup>(2)</sup> /AMFLMETO <sup>(3)</sup>
Touch-and-Go - Flaps 50%	5,000 feet
Touch-and-Go - Flaps 0% or 100%	6,000 feet
Normal Landing Distance	Landing Distance over 50 foot Obstacle <sup>(8)</sup>
Max Effort Landing Distance	Landing Ground Roll + 500 feet <sup>(4) (5) (6) (7)</sup>
<b>Minimum Runway Width</b>	
Normal/Max Effort Operations	60 feet (19 meters) <sup>(1)</sup>
<b>Minimum Taxiway Width</b>	
Normal/Max Effort Operations	30 Feet (9 Meters) <sup>(1)</sup>
<b>Notes:</b>	
<p>1. MAJCOM/A3 may waive runway length/width and taxiway width requirements.</p> <p>2. Use maximum effort takeoff procedures if available runway length is less than CFL.</p> <p>3. Minimum runway length for maximum effort operations is the ADJUSTED MFLMETO. Squadron Commander may approve the use of MFLMETO not corrected for VMCA and VMU3 if mission necessity dictates.</p> <p>4. Use maximum effort landing procedures whenever the runway available for landing is less than that required for a normal landing with outboard engines in High Speed Ground Idle (HSGI) and inboard engines in Max Reverse (2OB HGI; 2IB REV in the Performance Manual) and max anti-skid braking. Plan the touchdown within the first 500 feet of usable runway.</p> <p>5. Minimum runway length using max effort procedures is ground roll plus 500 feet if a 500 foot touchdown zone is clearly marked on the runway. If the touchdown zone is greater than 500 feet, or unmarked, minimum runway length is ground roll plus 1,000 feet.</p> <p>6. LZ markings may vary depending upon the supporting agency (refer to AFI 13-217). Markings being used will be established during mission planning and included in the aircrew briefing.</p> <p>7. On non-marked (AMP-4) runways, a go-around point will be identified to all crew members prior to execution.</p> <p>8. Crews may use landing ground roll plus 1,500 feet when approved by the squadron commander. In this case, ensure the landing touchdown is in the first 500 feet of the runway.</p>	

#### 6.19.4.5. Training:

6.19.4.5.1. Takeoff speed will be AMAX (terrain permitting) and runway length will be IAW **Table 6.8**. Squadron commanders may approve the use of actual max effort speeds (takeoff and obstacle clearance) on a case-by-case basis during training.

6.19.4.5.2. Simulated obstacle clearance height will not exceed 50 feet. (T-3)

### **6.20. Aircraft Taxi Obstruction Clearance Criteria.**

6.20.1. Without wing walkers, avoid taxi obstructions by at least 25 feet; with wing walkers, by at least 10 feet. **Exception:** Locally based aircraft may taxi within 25 feet of obstacles without a wing walker when fixed taxi routes are marked and the obstruction is permanent, but will still be no closer than 10 feet. Taxi routes must be used by the same model aircraft for which they were designed and in the specifically designed parking spots. Support equipment shall be located in appropriately designated areas. (T-3)

6.20.2. Whenever taxi clearance is doubtful, use a wing walker. If wing walkers are unavailable, deplane a crew member to ensure obstruction clearance.

6.20.3. If Foreign Object Damage (FOD) is a problem, the outboard engines may be shut down provided gross weight, taxiway conditions and weather are favorable.

6.20.4. After landing and clearing the runway, with the approval of the pilot, the loadmaster may open the aft cargo door and lower the ramp to approximately 12" above horizontal to prepare for cargo offload or on load. Ensure all equipment, cargo, and passengers remain secured in the cargo compartment.

6.20.5. Pilots will be advised of any known obstructions that penetrate shaded area in **Figure 6.1** (T-3)

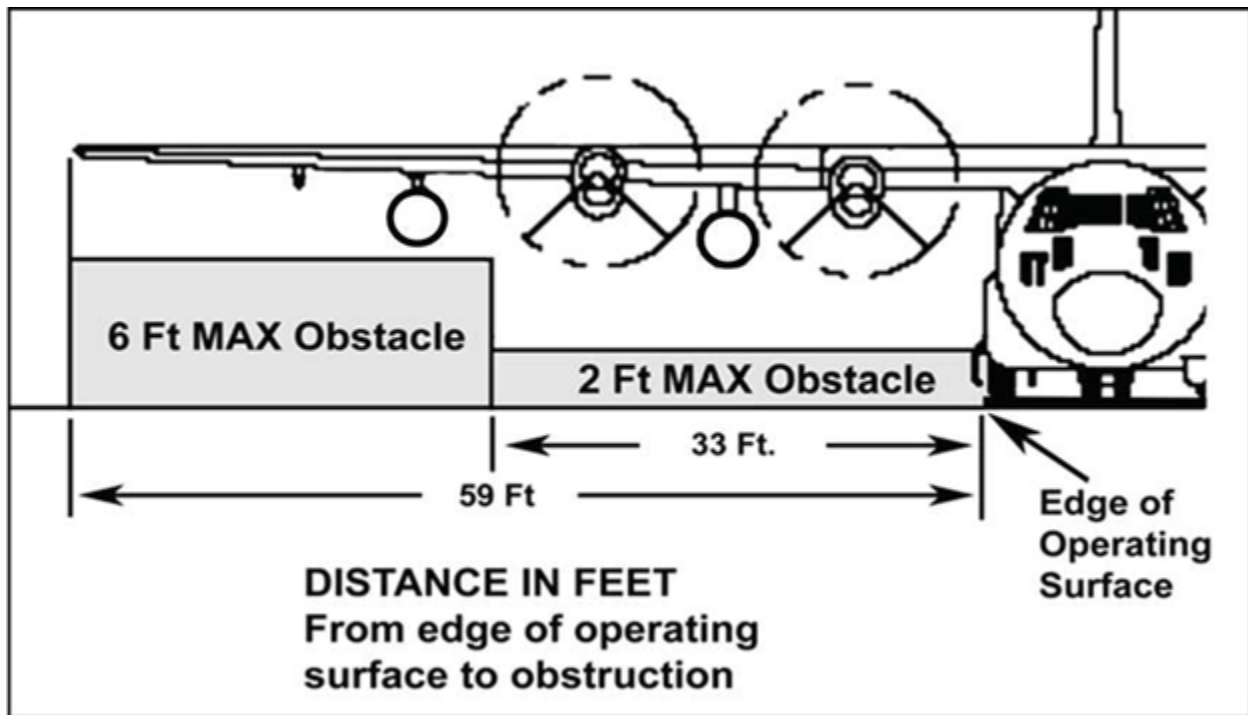
**Figure 6.1. Ground Operations Obstruction Clearance Criteria.****6.21. Reverse Taxi.**

6.21.1. The pilot will coordinate engine status/utilization with CP and taxi directions and signals with the loadmaster and marshaller prior to commencing reverse taxi operations. (T-3)

6.21.2. Secure all cargo and ensure all passengers are seated with seat belts fastened prior to aircraft movement.

6.21.3. Open the cargo door and lower the ramp to approximately horizontal.

6.21.4. The loadmaster will be on the aircraft ramp in the best position to direct reverse taxi, report any hazards, and provide the pilot with timely interphone instructions on turns, distance remaining, conditions of the maneuvering area, and stopping point. If four or five ground loading ramps or three canary slides are installed, at least one will be removed to allow unobstructed vision from the cargo ramp while backing. During night reverse taxi operations, the pilot and loadmaster will ensure that visibility in the taxi area is sufficient to conduct safe taxi operations. Do not taxi within 25 feet of an obstacle nor stop less than 25 feet from an obstruction, even if using wing walkers. (T-3)

**6.22. Takeoff and Landing Obstruction Clearance Criteria.**

6.22.1. PICs will comply with the ASRR requirements prior to operating at airfields classified as “special PIC airports” or “certification airfields” by the ASRR. (T-2)

6.22.2. An airfield is considered suitable for C-130 operations when no obstructions penetrate into the shaded area of **Figure 6.2**. This ensures obstruction clearance only if the aircraft is maintained within 35 feet of runway centerline and the angle of bank does not exceed 5°.

6.22.3. When an obstruction penetrates the shaded area of **Figure 6.2**, specific approval by the Group Commander/COMAFSOF (for contingency operations) is required and the PIC must be advised of the height and location of the obstruction, as well as specific procedures to avoid the obstacle (i.e., landing beyond the obstacle). (T-3)

**Figure 6.2. Takeoff and Landing Obstruction Clearance Criteria**

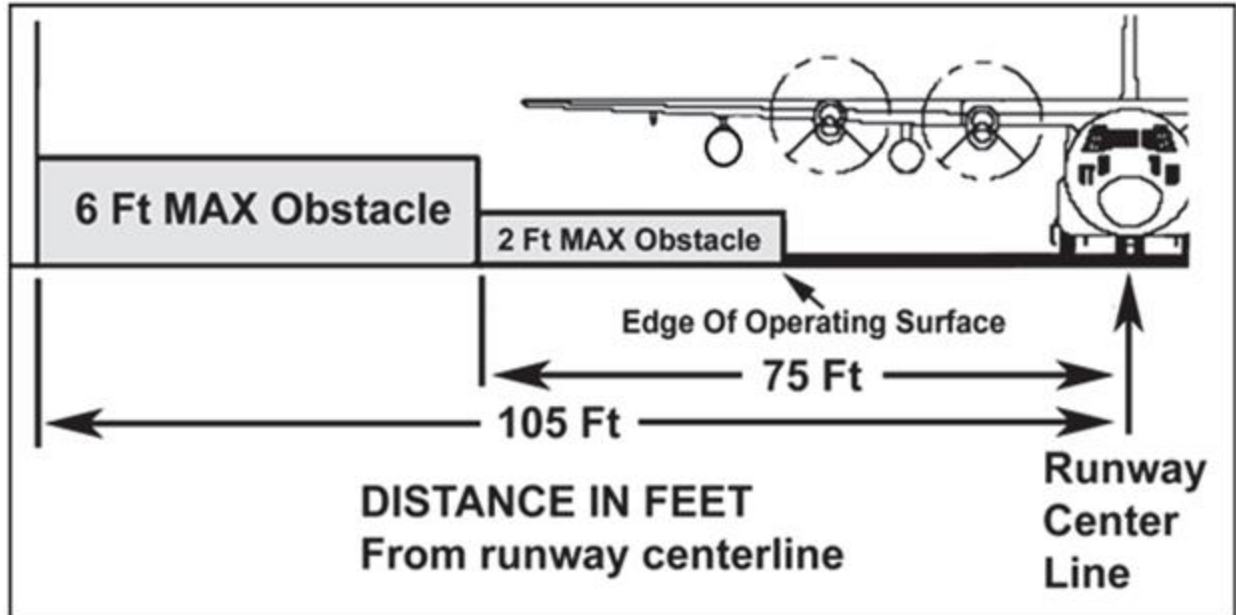

**6.23. Three-Engine Takeoffs.** Actual engine-out takeoffs require MAJCOM/A3 (COMAFSOF for contingency operations) waiver.

**6.24. Aircraft Recovery from Unprepared Surfaces.** Aircrews should not attempt to recover an aircraft after inadvertent entry onto surfaces that are not suitable for taxi. Ground crews using appropriate equipment will normally recover the aircraft. Aircrews may recover the aircraft at austere locations if, after thorough inspection, the PIC is sure there is no aircraft damage and the surface will support the aircraft.

**6.25. Engines Running Onload or Offload (ERO).** Do not use ERO procedures when explosive cargo (hazard class 1.1-1.4) is involved unless authorized by the exercise operation order or contingency air tasking orders. (T-2) Exception: Small arms ammunition hazard class 1.4S may be on/offloaded using ERO procedures providing the total NEW does not exceed airfield restrictions at the assigned on/offload location.

6.25.1. The ERO procedures in this paragraph may be used for any mix of personnel or cargo. The aft cargo door and ramp is preferred when more than 10 passengers are involved. The PIC will assess prevailing weather, lighting and parking location to ensure safe operations. (T-3)

6.25.2. General Procedures:

6.25.2.1. The PIC will brief crew members on the intended ERO operation, emphasizing specific crew member duties.

6.25.2.2. The parking brake will be set and one pilot will monitor brakes, interphone and radio.



6.25.2.3. Operate engines in ground idle (low-speed, if applicable). If conditions warrant, consider using Hotel mode to further reduce propeller blast.

6.25.2.4. Turn wing leading edge lights on during night EROs. Taxi lights may be used at the discretion of the pilot.

6.25.2.5. Complete passenger and cargo manifests, crew lists and DD Form 365-4, *Weight and Balance Clearance Form F*, for the subsequent sortie. **Note:** DD Form 365-4 is not required for the subsequent sortie if the aircraft will depart empty.

6.25.2.6. Resume taxi after the LM states the aircraft is “clear to taxi.”

6.25.2.7. Do not onload or offload through two different doors simultaneously. **WARNING:** Due to the hazards involved (i.e., propeller blast, proximity to engines and propellers, lack of paratroop door steps, etc.), only hand transferable items of cargo may be on/offloaded through the paratroop doors during EROs.

6.25.3. Personnel onload and offload through the crew entrance door.

6.25.3.1. The pilot will give clearance to open the crew entrance door.

6.25.3.2. During on/offload, station a crew member (normally the LM) on interphone (cord held taut) approximately 25 feet and at a 45° angle from the aircraft axis. (T-3)

6.25.3.3. Brief deplaning personnel to remain forward of the interphone cord.

6.25.4. Personnel or cargo on/offload through the aft cargo door and ramp.

6.25.4.1. After the aircraft has slowed to taxi speed, the LM may remove all tie-downs except one forward and one aft restraint. Remove remaining restraints only after the aircraft is stopped and vehicle drivers are in place. Drivers will not release vehicle parking brakes until all restraints are removed and cleared to proceed by the LM. (T-3)

6.25.4.2. Upon clearance from the pilot, open the aft cargo door and lower the ramp to approximately 12 inches above horizontal.

6.25.4.3. The LM will direct all on/offload operations using prebriefed signals. Passengers will be directed by a crew member when enplaning or deplaning. (T-2)

6.25.4.4. Other qualified LMs may direct the operation, if available, but the crew loadmaster retains overall responsibility for the operation.

6.25.5. Engine Running Crew Change (ERCC). The enplaning crew will not approach the aircraft until the deplaning LM is in position on headset outside the aircraft. (T-3) Keep ERCC to the absolute minimum necessary to accomplish the mission.

## 6.26. Stabilized Approach Philosophy.

6.26.1. The following criteria applies to all non-tactical approaches:

6.26.1.1. At FAF/GS intercept (IMC):

6.26.1.1.1. Airspeed is -10/+20 knots of computed approach speed for aircraft configuration

6.26.1.1.2. Aircraft is in a landing configuration

6.26.1.1.3. Sink rate is no greater than 1,500 Feet Per Minute (FPM).

- 6.26.1.1.4. All briefings and checklists are complete.
- 6.26.1.1.5. If these criteria are not met by FAF/GS intercept (IMC), the PM will announce the deviation.
- 6.26.1.2. At minimums (IMC) / 1 miles final (Visual Meteorological Conditions (VMC)):
  - 6.26.1.2.1. Airspeed is -10/+10 knots of computed approach speed for aircraft configuration.
  - 6.26.1.2.2. Aircraft is in a landing configuration
  - 6.26.1.2.3. All briefings and checklists are complete.
  - 6.26.1.2.4. If these criteria are not met by minimums (IMC)/1 mile final (VMC) for all non-tactical approaches, the PM will announce “Unstable, go-around.” The PF will execute a missed approach.
- 6.26.2. For tactical approaches and VFR patterns the PF is required to brief the maneuver parameters prior to execution. (T-3)

## Chapter 7

### AIRCRAFT SECURITY

**7.1. General. MC-130J aircraft are protection level "3" resources.** Refer to AFI 11-202, Vol 3 MAJCOM Supplement for procedures, aircraft force protection, protection standards for aircraft carrying distinguished visitors, aircrew arming requirements and anti-hijacking guidance.

## Chapter 8

### OPERATIONAL REPORTS AND FORMS

**8.1. General.** This chapter contains a description of applicable reports and forms. For assistance in completing safety forms contact the wing/group, unit or local flight safety officer.

**8.2. AF Form 457, USAF Hazard Report.** Refer to AFI 91-202, *The USAF Mishap Prevention Program*. The USAF hazard reporting system provides a means for AF personnel to alert supervisors and commanders to hazardous conditions requiring prompt corrective action. A hazard is any condition, act or circumstance that jeopardizes or may jeopardize the health and wellbeing of personnel, or which may result in loss, damage or destruction of any weapons system, equipment, facility or material resource.

**8.3. AF Form 651, Hazardous Air Traffic Report.** Refer to AFI 91-202, Attachment 3.

8.3.1. The Air Force Hazardous Air Traffic Report (HATR) program provides a means for personnel to report all near midair collisions and alleged hazardous air traffic conditions. Use information in HATR reports only for mishap prevention.

8.3.2. Procedures:

8.3.2.1. Make an airborne report of the hazardous condition to the nearest ATC agency (e.g., center, Flight Service Station (FSS), control tower, or aeronautical radio station), and give the following information as appropriate:

8.3.2.1.1. Identification or call sign.

8.3.2.1.2. Time and place (radial/DME, position relative to the airfield, etc.).

8.3.2.1.3. Altitude or flight level.

8.3.2.1.4. Description of the other aircraft or vehicle.

8.3.2.1.5. Include a verbal statement as soon as possible after occurrence that a written HATR report will be filed upon landing. **Note:** ATC agencies (e.g., FAA, etc.) must know if an official report is being filed. (T-2)

8.3.2.2. File the HATR as soon as possible (within 24 hours) using any available means of communication. Normally, it should be filed at the base operations office at the landing airport. If this is impractical and if communications permit, notify the safety office of the AF base where the condition occurred, the safety office at the home station, or as prescribed by the overseas MAJCOM. In any case, provide the safety office with all available information needed to prepare AF Form 651. Turn in a completed copy of AF Form 651 to the wing/group safety office. **Note:** HATR reports are not privileged information and may be released outside the AF.

8.3.3. Individuals submitting a HATR are granted immunity from disciplinary action provided:

8.3.3.1. Their violation was not deliberate.

8.3.3.2. They committed no criminal offense.

8.3.3.3. No mishap occurred.

8.3.3.4. They properly reported the incident using the above procedures.

**8.4. AF Form 711B, USAF Mishap Report .** Refer to AFI 91-204, *Safety Investigations and Reports*.

8.4.1. Responsibilities. Notify the appropriate authorities of any mishap involving aircraft or crew. When notified, units will initiate investigative and reporting actions in accordance with AFI 91-204. (T-2) **Note:** Do not attempt to classify a mishap.

8.4.2. Reportable Mishaps:

8.4.2.1. Report damage to the aircraft, or injury to the crew or passengers; as well as any damage or injury to another organization's equipment or personnel resulting from the movements or actions of an aircraft or crew.

8.4.2.2. Report the following occurrences:

8.4.2.2.1. A physiological episode. A physiological reaction, near accident, or hazard in-flight due to medical or physiological reasons. **Note:** In the event of a physiological episode, all crew members and passengers involved will report to a flight surgeon as soon as practical. Reportable incidents include:

8.4.2.2.1.1. Proven or suspected case of hypoxia.

8.4.2.2.1.2. Carbon monoxide poisoning or other toxic exposure.

8.4.2.2.1.3. Decompression sickness due to evolved gas (bends, chokes, neuro-circulatory collapse), or severe reaction to trapped gas resulting in incapacitation.

8.4.2.2.1.4. Hyperventilation.

8.4.2.2.1.5. Spatial disorientation or distraction resulting in an unusual attitude.

8.4.2.2.1.6. Loss of consciousness from any cause.

8.4.2.2.1.7. Death by natural causes of any crew member in-flight.

8.4.2.2.1.8. Unintentional loss of pressurization if cabin altitude is above FL180, regardless of effects on personnel.

8.4.2.2.1.9. Alcohol intoxication and hangover (crew only).

8.4.2.2.1.10. Illness (both acute and pre-existing), including food poisoning, dehydration, myocardial infarction, seizure, and so forth.

8.4.2.2.1.11. Exposure to toxic, noxious or irritating materials such as smoke, fumes or liquids.

8.4.2.2.2. In-flight flameout, engine failure, required engine shutdown, suspected engine power loss or loss of thrust sufficient to preclude maintaining level flight above Minimum En route Altitude **Note:** Intentional shutdowns for training and FCF are excluded; however, report failure to restart, using the criteria above.

8.4.2.2.3. Uncommanded propeller reversal.

8.4.2.2.4. Flight control malfunction resulting in an unexpected or hazardous change of flight attitude, altitude, or heading.

8.4.2.2.5. Malfunction of landing gear when difficulty is experienced using emergency system or procedures.

8.4.2.2.6. In-flight loss of all pitot-static instrument indications or all gyro stabilized attitude or directional indications.

8.4.2.2.7. Spillage or leakage of radioactive, toxic, corrosive or flammable material from aircraft stores or cargo.

8.4.2.2.8. All cases of departure from intended takeoff or landing surface onto adjacent surfaces.

8.4.2.2.9. Any incident which does not meet the established criteria for a reportable mishap but, in the judgment of the PIC, needs to be emphasized in the interest of flight safety.

**8.5. Reports of Violations/Unusual Events or Circumstances.** Violations identified in AFI 11-202, Vol 3, and navigation errors (including overwater position errors exceeding 24 NM, border, and ATC violations) will be reported.

8.5.1. Include the following: factual circumstances, investigation and analysis, findings and conclusions, recommendations, and actions taken.

8.5.2. Attachments should include; notification of incident, crew orders, statement of crew members (if applicable), and documenting evidence (logs, charts, etc.).

8.5.3. In addition to the information listed, the historical flight plan will be downloaded onto a floppy disk and turned in to the C2 center or owning standardization and evaluation office.

8.5.4. The following OPREP-3, *Event or Incident Report*, reporting procedures for all aircraft notified of navigational errors exceeding 24 NM will be reported under AFMAN 10-206, *Operational Reporting*:

8.5.4.1. On notification of a navigational position error, the PIC (or agency receiving notification) documents the circumstances surrounding the incident (report content below) and ensures submission of an OPREP-3 report through C2 channels.

8.5.4.2. Include the following:

8.5.4.2.1. Name and location of unit submitting report, mission identification number, reference to related OPREPs-3, type of event (e.g., state "navigation position error."), date, time (Zulu), and location (e.g., Air Route Traffic Control Center area).

8.5.4.2.2. Description of facts and circumstances. Include aircraft type and tail number, unit (wing/group or squadron assignment of crew), home base, route of flight, point of alleged deviation, and miles off course.

8.5.4.2.3. PICs must keep the appropriate agencies apprised of any unusual events or circumstances impacting their missions. Examples of reportable events include meaconing, jamming, intrusion, interception, fuel dumping, loss of multiple engines, hostile fire, injury to passengers or crew members, etc. This list is not exhaustive. Some events may require the C2 agency to forward OPREP reports to higher headquarters. The old adage, "when in doubt, report it," applies.

**8.6. Petroleum, Oil, and Lubricants (POL) - Aviation Fuels Documentation.** This section prescribes Aviation Petroleum, Oil, and Lubricants (AVPOL) procedures that ensure correct documentation, form and invoice processing, and program supervision. Reference DoDM 4140.25-M, Vol 2. Use the Multiservice Corporation (MSC) air card for the purchase of aviation fuel and ancillary ground services at commercial airports (and some military installations) worldwide. The air card is authorized for use by all US government aircraft, state, and local law enforcement aircraft, and some foreign government aircraft. All PICs should plan to use the platinum MSC card. In most cases, there will be no changes when refueling at non-Defense Energy Support Center (DESC) contract locations, a call for one time authorization may be required. The MSC card is accepted at approximately 4,800 locations worldwide. A list of all MSC-accepting merchants can be found at <https://www.airseacard.com>. It replaces the Standard Form (SF) 44, Purchase Order-Invoice-Voucher, at locations that accept the MSC card.

8.6.1. Responsibilities. Aircrew and maintenance personnel will be familiar with AVPOL procedures and documentation requirements of this chapter. (T-3) Improper use of the MSC card could create financial liability for the purchaser.

8.6.2. Refuel/defuel AF aircraft at DoD locations whenever possible. If DoD service is not available, purchase fuel from other source(s) in the following priority:

8.6.2.1. Defense Fuel Supply Center (DFSC) or Canadian into-plane contracts. **Note:** DoD FLIP en route supplements identify locations with into-plane contracts.

8.6.2.2. Foreign government air forces.

8.6.3. AVPOL Forms Documentation and Procedures.

8.6.3.1. The DD Form 1898, *Fuel Sale Slip*, is the fuel transaction receipt used for purchases at other DoD locations, including DFSC into-plane contract locations. Log and place the DD Form 1898 inside the AF Form 664, *Aircraft Fuels Documentation Log*. The PIC or designated representative shall complete this form. **Note:** If the contractor insists on a unique invoice along with the DD Form 1898, annotate the vendor's invoice with DUPLICATE DD Form 1898 ACCOMPLISHED. (T-3)

8.6.3.2. The AF Form 664, *Aircraft Fuels Documenting Log*, is a tool to log and store all AVPOL transaction forms. Record all off-station transactions on the front of the form and insert the original form inside the envelope. Turn in the AF Form 664, with supporting forms, to maintenance debriefing or as directed by local procedures. The PIC or designated representative shall complete this form when appropriate. (T-3)

8.6.3.3. The Standard Form (SF) 44, *Purchase Order-Invoice-Voucher*, may be used to purchase fuel, ground services, and/or other authorized products when no MSC card contract is in place.

8.6.3.3.1. SF 44 fuel purchases where Fixed Base Operator (FBO) agrees to invoice DESC for payment.

8.6.3.3.1.1. The aircrew shall present the SF 44 as the purchase invoice when an FBO refuses to accept the MSC card. The aircrew shall complete the SF 44 and attach it to the FBO vendor ticket/invoice when the FBO also declines use of the SF 44 and uses its own invoice/receipt. Fuel purchases shall be documented on a separate SF 44 from ground services and other authorized products since the FBO

must invoice DESC for the fuel and the customer for non-fuel product and services.

8.6.3.3.1.2. Copies 1 and 2 of the SF 44 shall be provided to the FBO. Copy 1 of the SF 44 and one copy of the FBO commercial invoice, if applicable, shall be forwarded to the following address by the FBO to bill/invoice DESC: DESC-RRF, Building 1621-K, 2261 Hughes Avenue, Suite 128, Lackland AFB, Texas 78236. (T-3)

8.6.3.3.1.3. Copy 3 of the SF 44 and one copy of the FBO commercial invoice, if applicable, shall be provided to the aircrew. Log and place a copy inside the AF Form 664. Aircrews shall present all fuel purchase receipts to the designated aviation squadron Certifying Official and/or Accountable Official upon return to home station to enable timely validation and financial obligation processing into the Fuels Automated System.

8.6.3.3.2. SF 44 fuel purchases where the FBO requires cash payment.

8.6.3.3.2.1. Cash fuel purchases are only authorized when either the Foreign Clearance Guide requires cash payment, or when FBO locations outside the United States and US Territories refuse MSC card and/or SF 44 invoicing processes. Aircrews required to pay cash for aviation fuel purchases shall employ the following procedures. (T-3) **Note:** These procedures do not apply to nonfuel products or services:

8.6.3.3.2.2. The aircrew shall obtain cash from a local DoD Finance source that is charged to an approved Treasury suspense account prior to home station departure. (T-3)

8.6.3.3.2.3. Aircrews shall complete the SF 44 and obtain the FBO fuel vendor annotation in block 11 of the SF 44 to confirm total cash amount and also sign and date the SF 44 blocks 20 and 21. Log and place a copy inside the AF Form 664. Aircrew shall return unused cash to their local DoD Finance source upon return to home station. Present the completed SF 44 (for non-fuel charges only) to the appropriate home station administrative personnel for processing (e.g., Wing Refueling Document Control Officer, Finance Office, etc.). (T-3)

8.6.3.3.3. SF 44 purchases of ground services and other approved products (not fuel).

8.6.3.3.3.1. Complete a separate SF 44 for nonfuel purchases. Provide the FBO copies 1 and 2 of the SF 44. The FBO shall use copy 1 and one copy of the FBO commercial invoice, if applicable, to directly bill/invoice the purchasing organization. Block 9 of the SF 44 shall reflect the organization name and address of the finance office responsible for payment to the FBO. The purchasing organization shall make payment to the FBO upon receipt of the invoice from the FBO. (T-3) Log and place a copy inside the AF Form 664.

8.6.3.3.4. If the vendor presents their own form for signature and accepts the SF 44, write the statement "SF 44 Executed" on the vendor's form. Turn in two copies of the SF 44 to the operations officer at home station.

8.6.3.3.5. Present the aircraft identification plate for purchases at approved locations. Make certain the invoice includes date of transaction, grade of product, quantity



issued/defueled, unit of measure, and signature of AF member who accepted product. If vendor also requires completed SF 44 write statement, "AF FORMS EXECUTED" on vendor's invoice. Log and place a copy inside the AF Form 664.

8.6.3.4. Purchasing Aviation Fuel in Canada. The DoD and Canadian Department of National Defense have signed a memorandum of understanding allowing DoD aircraft to use the DD Form 1896, Jet Fuel Identaplate, when refueling at Canadian airfields with a Canadian National Defense Contract (CNDC). Use the air card for fuel purchases at Canadian airports without a CNDC, and for ground handling services at all Canadian airports.

8.6.3.5. Use host country forms to effect purchases at foreign military airfields, including replacement-in-kind locations. Hand scribe information from aircraft identaplate on the local form. Log and place a copy inside the AF Form 664.

8.6.3.6. AF Form 1994, *Fuels Issue/Defuel Document*, records fuel purchases at AF bases using a valid DD Form 1896. The PIC or designated representative shall complete the form then log and place a copy inside the AF Form 664.

8.6.3.7. AFTO Form 781H, records POL actions for particular airframe IAW applicable directives. The PIC or designated representative shall complete the form and submit to maintenance debrief.

8.6.3.8. DD Form 1896, is the aircraft fuel and oil charge card.

8.6.3.9. The PIC will verify the AFTO Form 781H is completed and turned in to maintenance debriefing following the mission. (T-3)

8.6.3.10. For off-station missions, the PIC will complete or verify accuracy of the SF 44, AF Form 664, AFTO Form 781H, DD Form 1898, and associated fuels receipts then place them in the AF Form 664 (use eight digits for all AF aircraft tail number entries). The PIC will transmit all AF Form 664 information via phone, fax or message if mission causes him/her to be off-station past the last day of the month. (T-3)

**8.7. AF Form 15, United States Air Force Invoice.** Used to purchase ground fuels, oils or services at non-DoD activities. When completed, log and place inside AF Form 664.

8.7.1. Use the AF Form 15 for vendor services/supplies only if contract vendors are not available or the contract vendor will not accept the aircraft identaplate. (T-3)

8.7.2. If the vendors require a signature on their form and an AF Form 15 has been used, write the statement "AF Form 15 Executed" on the vendor's form.

8.7.3. Return two copies of the AF Form 15 to the operations officer at home station.

8.7.4. Purchases at Canadian into-plane locations will be documented using the local vendor's invoice. AF Form 15 will not be accomplished. Hand scribe the information from the aircraft identaplate to the vendor's invoice, and complete a separate sheet with the information listed on the Aviation Issues to DoD and Non-DoD, Aircraft Refueling Tender Sheet. Log and place a copy inside the AF Form 664. (T-3)

8.7.5. Purchases at SITCO Agreement locations require presenting the aircraft identaplate. The invoice must include the date of transaction, grade of the product, quantity issued or defueled, unit of measure, and signature of the AF representative. If the vendor also requires

completion of an AF Form 15 in addition to their invoice, annotate on the vendor's invoice "AF FORMS EXECUTED." Log and place the documentation inside the AF Form 664. (T-3)

8.7.6. Purchases at noncontract commercial airfields are accomplished using AF Form 15.

8.7.7. Purchases at foreign military airfields, including Replacement-in-Kind locations, the host country forms are used to record the purchase. Information from the aircraft identification plate should be hand scribed on the local form. Log and place a copy inside the AF Form 664.

**8.8. AF Form 853, *Bird Strike Report*. Submit this report upon notification of a bird strike via aircraft.**

**8.9. DD Form 1748-2, *Airdrop Malfunction Report (Personnel-Cargo)*. The DD Form 1748-2 is a tool to document any airdrop malfunction IAW AFJ 13-210(I), *Joint Airdrop Inspection Records, Malfunction/Incident Investigations, and Activity Reporting*. Consistent with safety, immediately report off-DZ drops/extractions to the controlling agency and proper safety channels. The AC or designated representative shall complete DD Form 1748-2 before entering crew rest. Exception: If a malfunction is due to a failure of the static line retriever or CDS remote timer system, the mission may be continued provided the 80 lb tie on the knife did not break, and the knife did not nick the gate. Use the opposite static line retriever and manually activate the retriever switch at FS 245 or perform a manual gate cut. The DD Form 1748-2 is not required, but a write-up in the AFTO Form 781A is required.**

## Chapter 9

### FLYING TRAINING POLICY

**9.1. General.** This chapter outlines requirements and restrictions for training and evaluation missions. Refer to AFI 11-202 Vol 1, *Aircrew Training*, AFI 11-202 Vol 2, *Aircrew Standardization/ Evaluation Program*, AFMAN 11-2MC-130J Vol 1, *MC-130J Aircrew Training*, and AFMAN 11-2MC-130J Vol 2, *MC-130J Aircrew Evaluation Criteria* for additional information.

**9.2. Instructor/Flight Examiner Briefings.** Before all training/evaluation missions, the PIC or instructors/flight examiners will brief their crew on the training/evaluation requirements, objectives, planned profiles and seat changes. (T-3)

**9.3. Debriefing.** Review and assess overall training performed. Each student or crew member should thoroughly understand what training has been accomplished. All required documentation should be completed as expeditiously as possible.

**9.4. Simulated Emergency Flight Procedures (EPs).**

9.4.1. Simulate EPs (engine shutdown, placing switches in other than their normal positions, or an abnormal configuration such as no flap landings or simulated engine failure) only during training, evaluation, or currency flights when an instructor or flight examiner pilot is in one of the pilot seats. Instructor pilot candidates who occupy a pilot seat and are under the supervision of a flight examiner pilot, not in a pilot seat, may practice simulated emergency procedures during initial or requalification upgrade evaluations. Preface all simulated emergencies with the word "simulated" and terminate simulated emergencies if an actual emergency arises.

9.4.2. One power lever may be retarded to FLIGHT IDLE at not less than  $V_{mca}$  (one-engine inoperative out of ground effect) and not less than 300 feet AGL.

9.4.3. Turns into the simulated inoperative engine(s) should be minimized. Such turns require a higher degree of pilot skill than with actual inoperative engines and must be smooth and coordinated. **WARNING:** Improper rudder or power application can lead to an immediate out-of-control condition where recovery may not be possible. (T-2)

9.4.4. Simulated EPs are prohibited with passengers on board unless such personnel are required for mission accomplishment, such as FCFs and test missions. Limit personnel to the absolute minimum required.

9.4.5. Conduct simulated EPs in accordance with AFI 11-202, Vol 3, and this manual. Use a realistic EP scenario and do not compound EPs. Limit simulated EPs to noncritical phases of flight when possible. Notify the controlling agency if a nonstandard traffic pattern or pattern requiring special sequencing is anticipated.

**9.5. Maneuver Restrictions.** All the following maneuvers require an instructor or flight examiner pilot unless otherwise specified.

9.5.1. Aborted Normal Takeoff. Authorized during daylight. Crosswind component must be within the recommended zone of the flight manual takeoff crosswind chart. Runway must be dry, hard-surfaced and long enough to allow refusal and takeoff speeds to be equal. Initiate the abort by stating "REJECT" before refusal speed. Do not practice aborts from touch-and-

go or stop-and-go landings. If actual engine shutdown due to a simulated malfunction is to be practiced, it must be prebriefed. (T-2)

9.5.2. Aborted Max Effort Takeoff. Authorized during daylight. Crosswind component must be within the recommended zone of the flight manual takeoff crosswind chart. Runway must be dry, hard-surfaced and long enough to allow refusal and takeoff speeds to be equal. Simulate a runway length less than critical field length. Initiate the abort by stating "REJECT" at or below a refusal speed based on simulated runway length. Comply with flight manual brake cooling restrictions. Do not shutdown an engine due to a simulated malfunction. Do not practice aborted max effort takeoffs from stop-and-go landings. (T-2)

9.5.3. No-Flap Landing. Authorized in conjunction with a simulated engine(s) inoperative landing. Maximum gross weight is 120,000 pounds, and the crosswind component must be within the recommended zone of the landing crosswind chart. Authorized in night VMC and day IMC if weather is at or above circling minimums. (T-2)

9.5.4. Go-Around or Missed Approach. Initiate VFR go-arounds no lower than 100 feet AGL when practicing simulated emergencies other than simulated engine failures. Initiate practice instrument missed approaches no lower than the minimum altitude for the approach. **Note:** Instructor/flight examiner pilot is not required. (T-2)

9.5.5. Simulated Engine-Out Go-Around or Missed Approach. Initiate simulated engine-out go-around at not lower than 200 feet AGL. Initiate simulated engine-out missed approach no lower than the minimum altitude for the approach. (T-2)

9.5.6. Simulated Engine-Out Landing. Simulate failure of the first engine not less than  $V_{mca}$  (one-engine inoperative) and not less than 300 feet AGL. Authorized in daylight IMC (circling minimums for the approach being flown), or night (1,000-foot ceilings and 2 SM visibility or circling minimums, whichever is higher). Use all 4 engines for touch-and-go takeoff. (T-2)

9.5.7. Unusual Attitudes and Spatial Disorientation. Authorized at not lower than 10,000 feet AGL in daylight VMC. (T-2)

9.5.8. Slow Flight. Fly at approach, threshold and 1.2 times power-off stall speed with gear down and flaps 0, 50, or 100%. Do not exceed 15° of bank. (T-2)

9.5.9. Practice Emergency Climb Procedure. Authorized in day/night VMC. Minimum airspeed should not be less than  $V_s + 20$  knots. An instructor or flight examiner pilot is not required for the accomplishment of this event. (T-2)

**9.6. Touch-and-Go Landings.** Authorized on designated training, evaluation or currency missions.

9.6.1. Touch-and-go landings may be performed by any current and qualified pilot from either the right or left seat under non-NVG and NVG conditions.

9.6.2. Touch-and-go landings are authorized when crosswind component corrected for RCR is within the recommended zone of the landing crosswind chart. Ceiling and visibility (RVR) must be at least 300 feet and 3/4-mile (4000 RVR). (T-2)

9.6.3. Touch-and go landings are normally performed at flight idle. Brief the crew if performing a ground idle touch-and-go landing. Do not perform no-flap ground idle touch-and-go landings. (T-2)

9.6.4. Touch-and-go landings are not authorized when normal wake turbulence criteria is not met or when intercepting or crossing the flight path of a large multi-engine jet during approach or landing.

### **9.7. Stop-and-Go Landings.**

9.7.1. Authorized on designated training, evaluation, currency sorties, or anytime mission requirements dictate. Any MC-130J qualified pilot may perform stop-and-go landings if:

9.7.1.1. The crosswind component corrected for RCR is within the recommended zone of the landing crosswind chart. Ceiling and visibility (RVR) must be at least 300 feet and 3/4-mile (40). (T-2)

9.7.1.2. Minimum braking is used to stop.

9.7.1.3. The runway remaining for takeoff is greater than CFL/AMFLMETO/MFLMETO.

9.7.2. Stop-and-go landings are not authorized:

9.7.2.1. In conjunction with no-flap landings.

9.7.2.2. When normal wake turbulence criteria is not met, or when intercepting or crossing the flight path of a large multiengine jet during approach or landing.

**9.8. Prohibited Maneuvers.** The following maneuvers will not be practiced or demonstrated in-flight: (T-2)

9.8.1. Full stalls.

9.8.2. Approach to stalls (except FCF).

9.8.3. Rudder force reversals (fin stalls).

9.8.4. Spins.

9.8.5. Simulated runaway trim malfunctions.

9.8.6. Simulated hydraulic system loss by turning engine-driven hydraulic pumps off.

9.8.7. Simulated two-engine approaches or landings.

9.8.8. Simulated engine-out takeoffs.

**9.9. Landing Restrictions with Airdrop Loads. Pilot proficiency/multiple maximum effort landings will not be accomplished with non-unilateral airdrop loads onboard the aircraft (i.e., Combat Rubber Raiding Craft (CRRC), Bike Bundles, Rigging Alternate Method Zodiac (RAMZ)) in order to prevent damage to actual loads. (T-2) If landings are accomplished with training loads (i.e., SATB, 55 gallon drum CDS loads, concrete blocks) on the aircraft, the loadmaster will reinspect the load prior to airdrop. If any damage is noted on the honeycomb, skid board, ties, lashings, etc., the load will be returned to Aerial Delivery. Training loads may remain onboard during assault landings and may be dropped after they are reinspected by the loadmaster prior to the airdrop. The intent is not to negatively impact training, but at the same time, minimize maximum effort landings with training loads on board.**

**9.10. Simulated Instrument Flight.** Simulated instrument flight may be flown and logged without use of a vision-restricting device. The use of a hood or other artificial vision-restricting device for any phase of flight is prohibited.

**9.11. Air-to-Air Refueling Training Restrictions.** During training missions the override signal amplifier will not be used. (T-2)

## Chapter 10

### LOCAL OPERATING PROCEDURES

**10.1. General.** Units will publish local and/or unique unit operation procedures as a supplement to this chapter commencing with “Paragraph 10.2”. The title will indicate the unit concerned (e.g., “10.2. 9 Special Operations Squadron Local Operating Procedures.”) (T-2)

10.1.1. Procedures in unit supplements will not duplicate, alter, amend or be less restrictive than those in this manual. (T-2)

10.1.2. After validation, send final copies to MAJCOM/A3V.

## Chapter 11

### NAVIGATION PROCEDURES

#### 11.1. General.

##### 11.1.1. Definitions and Terminology.

11.1.1.1. Category I (CAT I) Route. Any route that does not meet the requirements of a CAT II route, including tactical navigation and overwater routes.

11.1.1.2. Category II (CAT II) Route. Any route on which the position of the aircraft can be accurately determined by the overhead crossing of a radio aid (NDB, VOR) or intersection of at least two radio aid radials (VOR, TACAN) or one radial (VOR, TACAN) and one DME at least once each hour.

11.1.1.3. Controlling Navigation Solution. The INAV aircraft position solution that is used by the mission computer for en route navigation. The SHIP SOLN, selected via the NAV SELECT page of the AMU, determines which INAV (1/2) will be used to steer the aircraft either manually or with the autopilot.

11.1.1.4. First Suitable Airfield (FSAF) and Last Suitable Airfield (LSAF). Utilized in the equal time point (ETP) calculation. These are represented as the “First Nearest” and the “Last Nearest” airports in the ETP calculation in the PROGRESS pages of the CNI. They are airports closest to the coast out and coast in waypoints that meet applicable criteria for MC-130J operations. Forecast weather for the FSAF and LSAF must meet destination weather minimum filing requirements.

11.1.1.5. Equal Time Point (ETP). Geographic point along the route from which the flight time to the FSAF or the LSAF is equal.

11.1.1.6. Required Navigation Performance (RNP). RNP accuracy standards require an aircraft to remain within a specific number of nautical miles of its cleared course centerline for 95% of the duration of the flight. The associated track containment limit is twice the RNP value and represents the maximum limit of protected airspace. Airspace where RNP is applied is considered special qualification airspace. Both the operator and the specific aircraft type must be approved for operations in these areas. RNP airspace is being incorporated around the world to increase air traffic capacity by decreasing separation requirements between routes. Refer to FLIP Area Planning publications/charts to determine RNP airspace.

11.1.1.7. Area Navigation (RNAV). RNAV is a method of navigation permitting aircraft operation on any desired course (fix-to-tix) within the coverage and capabilities of the aircraft onboard navigation equipment.

11.1.1.8. Minimum Navigation Performance Specifications (MNPS) Airspace. MNPS airspace exists in both the North Atlantic Region (NAT) and certain Canadian portions of the North American Region. Refer to FLIP Area Planning publications/charts to determine MNPS airspace. The MC-130J must comply with all MNPS equipment requirements when flying within the lateral dimensions of this airspace. Aircraft meeting the North Atlantic MNPS requirements also meet the Canadian MNPS requirements. Aircraft entering MNPS airspace are required to have two Long Range Navigation Systems (LRNS) capable of



staying within 12.6 NM of cleared track for 95 percent of the flight. Gross navigation errors are those that exceed 24 NM from track center line. Prior to entering MNPS airspace, both Inertial Navigation Systems (INSs) must be fully operational to meet the MNPS requirement of having two fully serviceable LRNSs. In order to signify that a flight is approved to operate in NAT MNPS airspace, the letter “X” will be inserted within item 10 of the DD Form 1801 flight plan.

11.1.1.9. NAT Tracks. Contained within the North Atlantic MNPS airspace is an organized track system (NAT Tracks) between FL 285 and FL 420 to optimize air traffic based on meteorological data and are updated twice daily. When flying over the North Atlantic, crews should obtain a copy of the North Atlantic Tracks (NAT tracks) valid for their coast out time from the DoD Notice to Airmen (NOTAM) internet site.

11.1.1.10. Reduced Vertical Separation Minimum (RVSM) Airspace. This airspace requires special certification and exists to increase airspace capacity, safely, by reducing vertical separation from 2,000 to 1,000 between suitably equipped aircraft. RVSM has been implemented in the CONUS, Europe, Africa and Middle East. RVSM airspace typically extends from FL 290 through FL 410. Consult FLIP Area Planning 1 and 2 (AP/1 and AP/2) for locations and lateral and vertical dimensions of this airspace.

## **11.2. Special Certification Airspace Requirements and Procedures.**

11.2.1. The CNI-MS supports worldwide operations in oceanic, en route and terminal areas which require RNAV capabilities. The MC-130J GPS does not employ Receiver Autonomous Integrity Monitoring (RAIM) or Fault Detection and Exclusion (FDE), the EGI or GPS cannot be used for civil IFR operations unless automatically monitored using the INS or INS/RAD calculated positions. AFI 11-202, Vol 3 allows MAJCOM authorization of the GPS to be used as a mission enhancement system for en route instrument navigation, if it is used to update a self-contained navigation system, such as INS or mission computer, and is checked against other approved sources (in this case an RNP-10 certified INS). Therefore, on CAT II routes (not including operations in BRNAV airspace), the EGI or GPS can be used as the controlling solution for en route instrument navigation if NAVAIDs are available for monitoring. The NAVAIDs must be operational and actively monitored. If deviations are observed, crews should revert to navigation via ground based NAVAIDs. For operations over CAT I routes (not including operations in RNP-10 airspace), the EGI or GPS can be used as the controlling solution providing the pilot can monitor its performance using the offside INS as an independent navigation source. The EGI or GPS cannot be used as the controlling solution in BRNAV or RNP-10 airspace, even when using INS as the sole input source for the EGI.

11.2.2. The MC-130J is certified for RNAV operations as listed in TO 1C-130(M)J-1. See [Attachment 7](#) for a consolidated list of MC-130J operations in RNAV airspace.

11.2.2.1. RNP-10 airspace requires a track keeping accuracy of 10 NM for 95% of the flight. The track containment limit is 20 NM. The MC-130J navigation system has been certified to meet the requirements of RNP-10 airspace for up to 10 hours from the time the controlling INS was commanded to the NAV mode. The pure INS solution is the only certified navigation solution for flying in this airspace. Annotate the letter “R” in Block 10 of the DD Form 1801 or appropriate block of the ICAO flight plan to indicate RNP-10 certification.

11.2.2.2. BRNAV/RNP-5 airspace requires a track keeping accuracy of 5 NM for 95% of the flight. The track containment limit is 10 NM. Minimum equipment to operate in this airspace is one INS capable of updates. The INS/RAD or INS-only solution will be the controlling INAV solution in this airspace. The INS/RAD solution can be used without time restrictions if the solution is being updated from NAVAIDs. If the NAVAIDs become unreliable, either through radio failure or denial, the INS-only solution will still maintain BRNAV accuracy for 2.6 hours from the time the controlling INS was commanded to the NAV mode. If needed, an in-flight alignment may be used to restart the time-in-NAV of an INS prior to entry into this airspace. INS/RAD or INS-only solution will be selected prior to entering BRNAV airspace. The AUTOTUNE function of the CNI-MS must be enabled. BRNAV airspace currently exists throughout the European Region. Because BRNAV airspace exists only where NAVAID reception is available, CAT I procedures are not required. Annotate the letter "R" in Block 10 of the DD Form 1801 or appropriate block of the ICAO flight plan to indicate BRNAV certification. (T-2)

11.2.3. Reduced Vertical Separation Minimum (RVSM) Airspace. Airspace where RVSM is applied is considered special qualification airspace. Both the operator and the specific aircraft type must be approved for operations in these areas. The MC-130J is RVSM certified. Pilots will refer to FLIP AP/2, TO guidance, and the following for RVSM requirements: (T-2)

11.2.3.1. Both primary altimeters, at least one autopilot, the altitude advisory system, and the transponder, must be fully operational. The AC will request a new clearance to avoid this airspace should any of this equipment fail. (T-2)

11.2.3.2. Have the autopilot engaged during level cruise, except when circumstances such as the need to re-trim the aircraft or turbulence require disengagement.

11.2.3.3. Limit climb and descent rates to 1,000 feet per minute when operating near other aircraft to reduce potential TCAS advisories.

11.2.3.4. Immediately notify ATC if any of the required equipment fails after entry into RVSM airspace and coordinate a plan of action.

11.2.3.5. Document in the aircraft forms malfunctions or failures of RVSM required equipment.

### 11.3. Mission Planning Procedures.

11.3.1. Mission/Route Planning. Aircrew will normally accomplish and verify mission planning while in a flight planning facility/base operations; the data is then loaded manually (or via the data transfer card) into the CNI. (T-3) Pilots will also calculate and verify the required ramp fuel load. (T-3) Refer to [Chapter 12](#) to accomplish fuel planning.

11.3.2. One computer flight plan (CFP) and one plotting chart will be used as master copies for each flight utilizing CAT I procedures. (T-3) Both will be labeled "MASTER COPY" and will be referred to as Master Flight Plan (MFP) and Master Plotting Chart (MPC). (T-3)

11.3.2.1. CFP. When practical, aircrew will plan the most direct routing or utilize wind optimized CFP routing to enhance fuel conservation. (T-3) Optimized routing with applied forecast winds can be obtained from Advanced Computer Flight Plan (ACFP) (AF) or Optimum Path Aircraft Routing System (OPARS) (USN). Use initial ATC cruise ceiling for the en route altitude when not restricted by fuel temperature freezing limits.

11.3.2.2. Verify the CFP for route definition and accuracy, paying particular attention to adherence with over flight clearances.

11.3.2.3. MFP Usage. The MFP is normally maintained by the CSO or PM but should be kept readily available to both pilots. It will be used to record the following in-flight: (T-3)

11.3.2.3.1. All ATC clearances and changes to clearances.

11.3.2.3.2. The wind, temperature, altitude, fuels remaining, and the bearing/range between the INAV solutions over waypoints bordering and within CAT I Navigation airspace.

11.3.2.3.3. Any loss or degraded navigation/avionics equipment.

11.3.2.3.4. Compass deviation checks.

11.3.2.3.5. Oceanic Navigation Accuracy Check.

11.3.2.4. MFP Symbology. Use the following symbology to ensure that both pilots/CSO can easily determine which waypoints have been programmed into the CNI-MU, which programmed waypoints have been verified, and which waypoints have been transitioned in-flight.

11.3.2.4.1. Place a check mark next to the waypoint to signify the waypoint has been entered into the CNI-MU and the course and distance have been verified.

11.3.2.4.2. Circle the check mark to signify the coordinates, course and distance in the CNI-MU have been verified by another crew member.

11.3.2.4.3. Draw one diagonal line through the circled check mark to signify the waypoint has been passed, reported, and all applicable annotations associated with waypoint passage have been completed.

11.3.2.4.4. Cross the first diagonal line with another to signify that the aircraft's position has been plotted on the MPC approximately 60 NM (10 to 15 minutes depending on groundspeed) after waypoint passage.

11.3.3. Refer to **Chapter 12** to accomplish fuel planning.

11.3.4. Equal Time Point (ETP) Computations. The ETP provides crews a basis for recovery airfield decision making when in-flight emergencies occur. Wind Factor and ETP data computations are required on Category I routes or Category I route segments where the total time between last suitable airfield (LSAF) and first suitable airfield (FSAF) is 5 hours or more. Suitable airfields are those normally within 100 NM of flight planned course centerline meeting weather, fuel, and MC-130J runway requirements. In-flight refueling missions may require a separate ETP computation for each fuel analysis route segment, and the ETPs should be considered when planning the location of refueling tracks. Plan to have sufficient fuel at each end air refueling (EAR) point to divert to a planned AAR abort base, in the event an in-flight refueling is not completed. Use a point abeam the AAR abort base as the LSAF or FSAF for wind factor computations, and ETP data. ETPs must be annotated and plotted on the MPC and MFP prior to the coast-out waypoint. (T-3) **Note:** Wind factor and ETP computations are not normally required for round robin missions. **Note:** Refer to **Chapter 6** of this manual for runway, taxiway and airfield requirements.

11.3.4.1. ETP CFP Computations. The blocks provided on top of the MC-130J CFP should be used to record information needed by the CNI to compute an ETP. These blocks and provided formulas also serve as a worksheet for crews to do the manual ETP computation. Manual ETPs are mission-planned using flight-planned conditions. The manually calculated ETP will be plotted on the MPC and applicable data transferred to the CNI Progress page 3/3 during preflight. CNI-computed ETPs only become accurate upon reaching the PERF CRUISE altitude. CNI-computed ETPs can be obtained for different airspeeds (i.e., 260 KTAS for a 3-engine scenario).

11.3.4.1.1. LSAF/FSAF. To compute an ETP identify and record the LSAF, coast-out point, approximate midpoint (determined by distance), coast-in point, and FSAF. The coast-out point, approximate midpoint, and coast-in point are actual waypoints on the flight plan. For wind factor calculation purposes the coast-out point must occur at or after initial level off.

11.3.4.1.2. Wind Factors (WF). First and second half wind factors are computed between the coast-out point and coast-in point using the approximate midpoint as a division. Flight planned values for distance, time and average flight planned True Airspeed (TAS) will be used to calculate wind factors. If either first or last suitable airfields are more than 50 NM from the planned route, an alternate wind factor computation may be required.

**Note:** For wind factor computation convenience, coast-out means level off, abeam or over LSAF, or closest planned checkpoint or radio aid within 100 NM of LSAF. Coast-in means abeam or over FSAF, closest planned checkpoint or radio aid within 100 NM of FSAF, descent point or overhead destination. Calculate wind factors as follows: **Average Ground Speed = Total Distance / Total Time.** Subtract the average flight planned true airspeed (TAS) from the average ground speed to obtain the wind factor. **WF = Average Ground Speed - Average TAS**

11.3.4.1.2.1. First Half (WF1). Compute the average ground speed between coast out point and the approximate mid-point between the LSAF and FSAF. Subtract flight-planned average TAS from the computed average ground speed to obtain the 1st half wind factor.

11.3.4.1.2.2. Second Half (WF2). Compute the average ground speed between the approximate mid-point and the coast in point. Subtract flight-planned average TAS from the computed average ground speed to obtain the 2nd half wind factor.

11.3.4.1.2.3. Total Wind Factor. Total wind factor calculations are optional.

11.3.4.2. Equal Time Point Data. Emergency and in-flight fuel management decisions will be made relative to the ETPs. Use the following instructions to compute ETP data:

11.3.4.2.1. DISTANCE (LSAF TO FSAF). Enter the total distance (regardless of level off) from LSAF or abeam the LSAF along course from departure to or abeam the FSAF along course toward destination. The distance for ETP computations will be computed between the LSAF and FSAF, preferably within 50 NM of the planned track. For missions with a single or multiple in-flight refuelings, LSAFs and FSAFs may routinely exceed the 50 NM criteria and require multiple ETP computations incorporating air refueling abort bases.

11.3.4.2.2. The wind factors will be used in conjunctions with the best range TAS for ground speed to return ((GSR= (TAS+WF2)) and ground speed to continue ((GSC= (TAS-WF1)) to determine the ETP (NM) distance and ETP Time (T).

11.3.4.2.3. The following ETP formulas should be used:

$$\text{ETP DIST} = ((\text{DIST LSAF to FSAF}) / (\text{TAS-WF1} + \text{TAS+WF2})) * (\text{TAS-WF1})$$

$$\text{ETP TIME} = (\text{ETP DIST}) / (\text{TAS-WF1})$$

11.3.4.2.4. ETP Dist is the distance from the LSAF to the ETP and will be plotted and labeled on the navigation chart.

11.3.4.2.5. The ETP Time is the calculated en route time from the ETP to the FSAF, and equal to the time from the ETP back to the LSAF. This time will be used for fuel calculations, when information references ETP Time (T).

#### 11.4. Preflight Procedures.

11.4.1. Preflight procedures must include a Coordinated Universal Time (UTC) time check and resynchronization of the aircraft master clock, if necessary. Aircraft clock errors resulting in position report time errors can lead to an erosion of actual longitudinal separation between aircraft. Acceptable time standards that can be used include GPS (corrected to UTC), Naval Observatory Master Clock (DSN 762-1401/1069 or 560-6742), and WWV (2,500, 5,000, 10,000, 15,000, 20,000 kHz).

11.4.2. Preflight Communications Check. A pre-flight check of the SATCOM (if equipped) and HF radios should be made to a suitable agency (operating authority, command post or ATC).

11.4.3. Navigation Initialization and Solutions. Both the AUTONAV and manual Gyrocompass (GC) alignment of the INSs result in the required navigation performance needed for RNP RNAV operation. The GPS positions may be used as initial positions as long as they agree within one-tenth of one minute. If GPS is not available, use precision parking coordinates or, as a last resort, obtain coordinates from an airfield diagram published in an approved instrument approach book. This position must be checked and verified by 2 crew members and recorded on the MFP. (T-3)

11.4.4. Communication/Navigation/Identification Management System (CNI-MS). In addition to [Chapter 5](#) requirements, when configuring for CAT I operations, crews will configure the CNI-MS IAW applicable TO RNAV/RNP procedures prior to loss of RNAV/RNP capability, to include setting the non-controlling ship solution to INS only when applicable, and follow CAT I position alert procedures thereafter. (T-3)

11.4.5. Loading the Route of Flight. Because CAT I routes usually involve the manual input of waypoints not found in the database, and often require aircraft maximum range capability, it is critical that both pilots and CSO work in sequence and independently to enter accurate route-of-flight data. It is not sufficient for one crew member to simply observe another crew member entering the data. The following steps will be completed by the pilots and CSO:

11.4.5.1. Load the route of flight directly from the filed flight plan, MFP or data transfer card into the CNI and verify both the magnetic course and the leg distance for each waypoint with the MFP. Loading the route directly from the filed flight plan may minimize

pilot/controller clearance loop (misinterpretation) errors. Label waypoints so they can be readily identified for subsequent position reporting. If the courses differ by more than 2° or the distances differ by more than 2 NM, the pilot will resolve the discrepancy prior to flight. Completion of this step will be annotated with a check mark next to the waypoint. (T-3)

11.4.5.2. Using the LEGS pages, insert the forecast winds (if available) at each waypoint. (T-3)

11.4.5.3. Verify the total distance to the destination on the CNI PROGRESS page. Any significant disparity (more than 25 NM to allow for Standard Instrument Departures (SIDs)/Standard Terminal Arrivals (STARs) and approaches) in the total distance between the CNI and MFP will require a recheck of the ramp position and waypoint coordinates. (T-3)

11.4.5.4. The other pilot or CSO will verify the waypoint coordinates and course and distance information from the opposite side CNI to the MFP. Completion of this step will be annotated with the check mark being circled on the MFP. (T-3)

11.4.5.5. If the planned route of flight is a stored route or one loaded during a data transfer, verification of waypoint coordinates must still be accomplished by both pilots/CSO in the same manner. (T-3)

## **11.5. CAT I In-Flight Navigation Procedures.**

11.5.1. This section provides general procedures and guidance for the operation of navigation systems on CAT I routes. For navigation system requirements, consider all oceanic airspace as MNPS airspace. Specific procedures for RNP RNAV airspace are addressed in previous sections.

### **11.5.2. Navigation System Accuracy Checks.**

11.5.2.1. Ground. After leaving the ramp, perform the INS/INAV groundspeed check by stopping the aircraft and checking each pilot's groundspeed on the CNI-MUs or HDDs/HUDs. Groundspeeds in excess of 1 knot while the aircraft is stationary may indicate a faulty INS.

11.5.2.2. Airborne. Determine INAV position accuracy by comparing it to en route NAVAIDS.

11.5.3. Compass Deviation Check. Perform a compass deviation check using both INSs and the standby compass prior to entering CAT I airspace. Perform subsequent checks after heading changes of 30° (or greater) or every 3 hours. Record the deviation in the appropriate block of the MFP. Apply this correction to headings to be flown whenever it is necessary to use the standby compass as the sole source for navigation.

11.5.4. Oceanic Navigation Accuracy Check. Prior to coast-out, evaluate/compare the accuracy of all navigation solutions. In the event of discrepancies, greater than 4 NM, the crew should investigate the cause and determine if CAT I flight is feasible. Record this gross error check in the appropriate block of the MFP. If a pure INS position is determined to be more than 4 miles in error, an in-flight alignment may be accomplished provided sufficient time is available prior to entering RNP RNAV or oceanic airspace. If coast-out is made at a

radial/DME fix, the appropriate radial should be selected on the non-active Course Deviation Indicator (CDI) as a further check that the navigation system is tracking to the fix.

11.5.5. Communications. In addition to guidance in **Chapter 5**, crews will accomplish the following: (T-2)

11.5.5.1. Emergency Frequency Monitoring. In the interest of safety during oceanic and remote area operations (100 NM offshore), flights should maintain a listening watch on 121.5 and 243.0 MHz and the VHF common frequency.

11.5.5.2. BIU Backup. Ensure that one of the pilots place their transmission switch to an HF radio so that the crew can transmit on HF in case of BIU Backup. The other pilot should select VHF 2 for the same reason. VHF 1 will be available on the Get Home Control and crew can attempt to relay transmissions to other aircraft on 121.5 until within VHF range of ATC.

11.5.6. Oceanic Clearance. If not received before takeoff, the oceanic clearance should be obtained prior to the boundary of oceanic airspace IAW FLIP.

11.5.6.1. The clearance will be recorded on the MFP, and reviewed by both pilots/CSO. If the oceanic clearance received is different from the planned clearance, use the following procedures:

11.5.6.2. Record the new route on the MFP to include applicable updates to ETP data. (T-2)

11.5.6.3. Enter the new waypoints into the CNI IAW the preflight procedures in this chapter. (T-2)

11.5.6.4. Ensure the fuel will still be sufficient to arrive at the destination waypoint with required reserves. (T-2)

11.5.6.5. Mark out the old plotted track and draw the revised plot on the MPC. (T-2)

11.5.6.6. In no case should this process simultaneously engage the attention of both pilots during flight.

11.5.7. Approaching Coast-Out. Prior to coast-out and outside of RNP RNAV airspace it is permissible and recommended to use the EGI or GPS (INAV source in AUTO mode) as the INAV solution for both CNI-SPs if NAVAIDs are available for monitoring. Prior to losing NAVAID reception, the INAV solution that is not the controlling solution must be placed to INS. This ensures there is constant comparison of the controlling solution to an independent INS solution. Beginning at the coast-out waypoint and continuing through coast-in, CNI-MU bearing/range between INAV solutions should be recorded at each waypoint to provide a running record of INS drift relative to the controlling solution.

11.5.8. IFF. Reset Mode 3A code to 2000, 30 minutes after entering Category I airspace.

11.5.9. MFP and MPC Procedures.

11.5.9.1. MPC Usage. The use of a plotting chart is required on every route requiring CAT I Navigation. Use an appropriate Jet Navigation Chart (JNCA) or better chart with Lambert Conformal Conic projection. During mission planning, draw the course line representing the planned route of flight on the MPC and highlight the associated suitable

emergency airfields. The PIC will verify this information and annotate the chart with his/her signature, date, and mission number/call sign. During flight, 10 to 15 minutes (depending on groundspeed) after each CAT I waypoint, the PM/CSO will Mark Position and then plot the INS-only position on the MPC (using a dot surrounded by a triangle) and annotate the marked time and position coordinates adjacent to the plot. The PM/CSO should compare the plotted point to the course line. This procedure confirms that the navigation system is steering the airplane to the correct waypoint.

11.5.9.2. After takeoff, record the takeoff time in the Actual Time of Arrival (ATA) block of the departure airfield on the MFP. As soon as practical after takeoff, determine a revised Estimated Time of Arrival (ETA) for each line of the MFP using flight-planned leg times and the actual departure time. Record the fuel consumption comparison of the MFP.

11.5.9.3. Prior to waypoint transition, check the MFP magnetic course and distance to the next waypoint against the CNI-MU. The courses should be within 2° and the distances should agree within approximately 2 NM. Check and verify that the subsequent waypoint is properly programmed. Update ETAs to the next two waypoints.

11.5.9.4. Overhead the waypoint, confirm the ATA and determine the minutes ahead/behind by comparing it to the ETA. Record the CNI-MU bearing/range between INAV solutions to provide a running record of INS drift relative to the controlling solution. Record the actual fuel remaining above the flight-planned continuation fuel and write the difference between continuation fuel and actual fuel remaining in the EXCESS block of the MPF.

11.5.9.5. On CAT I routes, prior to the ETP, if the EXCESS fuel becomes negative the PIC will consider and accomplish one of the following recommended actions: (T-2)

11.5.9.5.1. Change the flight profile to ensure planned performance is reacquired and Fuel Reserves at destination will be met or exceeded.

11.5.9.5.2. Continue and land short of the intended destination (i.e., First Suitable Airfield (FSAF)) or proceed to intended destination based on an updated weather forecast that no longer requires an alternate.

11.5.9.5.3. Return to the departure base of the Last Suitable Airfield (LSAF).

11.5.9.6. The fuel recording portion of the master flight plan may be discontinued at the discretion of the PIC when ALL of the following conditions have been met:

11.5.9.6.1. The ETP has been crossed (CAT I routes).

11.5.9.6.2. Fuel systems and quantity indicators are functioning normally.

11.5.9.6.3. There is obvious extra fuel and the +EXCESS fuel trend is favorable.

11.5.9.6.4. All AARs have been completed.

11.5.9.7. Immediately after waypoint passage, and as soon as the aircraft has intercepted its new course, confirm that the aircraft is outbound on its flight planned magnetic course to the next waypoint and record the bearing/range between INAV solutions found on the INAV 1/3 page.



11.5.9.8. Record the actual in-flight conditions (altitude, wind, and static air temperature (SAT)) above the forecast conditions on the next line of the MFP. Update these conditions as well as fuel flow as needed on the PERF CRUISE and LEGS pages in the CNI-MU.

11.5.9.9. If required, complete a position report to the controlling agency in accordance with FIH procedures. The layout of the CNI PROGRESS page supports the format of the position report; however, ensure that ETAs passed to the controlling agency match the ETAs on the MFP. This will enable the pilots to determine if an ETA has changed from what was previously reported. If an ETA changes by more than 3 minutes, notify the controlling agency.

11.5.9.10. Draw a diagonal line through the waypoint on the MFP to indicate it has been passed, reported, and all applicable annotations associated with waypoint passage have been completed.

11.5.9.11. Approximately 60 NM (10 to 15 minutes depending on groundspeed) after waypoint passage, change INAV controlling solution to INS-only solution (will require disengaging NAV CAPT flight director guidance) and MARK the aircraft position. Switch back to the other INAV (EGI or GPS) and plot the INS-only position on the MPC. Record the mark time and position coordinates next to the plot. If the plotted position is not within 2 NM of the course centerline, check waypoint coordinates for accuracy, ensure the autopilot is tracking correctly in NAV mode, recheck the accuracy of the charted course-line, and recheck that the position was plotted correctly.

11.5.9.12. Cross the first diagonal on the MFP to indicate that the aircraft position has been plotted.

11.5.9.13. When the frequency of waypoints along CAT I route segments is greater than one every thirty minutes, full-line entries and plotting can be limited to a minimum of one every hour. Full-line entries with the corresponding position plot are required for every waypoint involving a change of heading over 20°.

11.5.9.14. Routine Monitoring. Crews should monitor aircraft performance and outside parameters, suspect potential problem areas, and review the Performance Manual if the following conditions are encountered:

11.5.9.14.1. The fuel remaining is less than the planned continuation fuel.

11.5.9.14.2. Any Low Calculated Fuel CNI-MU Advisory.

11.5.9.14.3. ATA at any MFP fix is off by more than  $\pm 5$  minutes.

11.5.9.14.4. SAT differs by more than  $\pm 5^\circ$  C from flight plan.

11.5.9.14.5. Actual winds differ by more than 30° or 15 knots from flight-planned.

11.5.9.14.6. Any Ahead/Behind Time more than 10% of total planned en route time to that point.

11.5.9.14.7. Hazardous meteorological conditions.

11.5.9.15. Approaching Landfall. Use the radar to help identify the coast-in position. When the aircraft is approaching the first landfall NAVAID, tune and identify the navigation facility and cross-check the aircraft position. If coast-in is made at a

radial/DME fix, the appropriate radial should be selected on the non-active CDI as a further check that the navigation system is tracking according to the current clearance. Once NAVAID reception is assured and flight is not being conducted in RNP RNAV airspace, all INAV solutions can be returned to AUTO. If entering BRNAV airspace, AUTOTUNE the NAVAIDS, select INS/RAD as the controlling solution, and place the other INAV solution in AUTO. Revert to CAT II procedures. Reset POS ALERT and IFF Mode 3 as appropriate.

## **11.6. Navigation Malfunctions and Failures.**

11.6.1. Should INAV solutions noticeably separate and exceed 8 NM, determine and use the INS solution considered most accurate by evaluating both INSs using available radio aids, ground mapping radar and GPS. Highest validity should be given to positions referenced via radar. Next highest validity should be given to positions derived via radio aid fixing. When left to determine the most probable position (MPP) via navigation solution comparisons, two agreeing INS positions are more valid than two agreeing GPSs; and two agreeing GPSs and one agreeing INS indicate a probable INS problem. Consider INS-radar/NAVAID, INS-INS and INS-GPS position comparisons that are less than 4 NM difference to be valid and in agreement. Once the most accurate INS is determined, select it as the controlling solution. Update ETAs to ATC if required.

11.6.2. Situations may arise when crews cannot identify the faulty navigation system by simple comparison of positions between navigation solutions. Fly the aircraft halfway between the disagreeing INS solutions. Plot both CNI-SP solutions at least once every 30 minutes on the MPC, labeling the pilot CNI-SP navigation solution MPP1 and the copilot's MPP2. Continue to evaluate outputs from each INS and try to use plotted position information to identify adverse trends.

### **11.6.3. Malfunctions and failures in MNPS airspace:**

11.6.3.1. Crews experiencing deterioration or failure of navigation equipment that reduces the capability to comply with MNPS prior to MNPS entry will return to a suitable airfield with a maintenance repair facility. (T-3)

11.6.3.2. Crews experiencing deterioration or failure of navigation equipment after entry into MNPS airspace should immediately report the malfunction to the controlling agency and subsequent agencies throughout the route of flight. Once the aircraft has entered oceanic airspace, the PIC should continue to operate the aircraft in accordance with the Oceanic Clearance already received, appreciating that the reliability of the total navigation system has been significantly reduced. The PIC should also prepare a proposal to ATC with respect to the prevailing circumstances and consult with ATC as to the most suitable action.

11.6.3.3. If an aircraft in MNPS airspace is unable to continue flight in accordance with its ATC clearance for reasons such as severe turbulence, aircraft performance problems, or pressurization failure, a revised clearance should be obtained as soon as possible. If unable to obtain a new clearance, offset 30 NM from the assigned route by turning 90° from track and maintain altitude if possible. Once offset 30 NM, climb or descend to an altitude which differs from those normally used by 500 feet.

11.6.4. Malfunctions and failures in RNP-10 or BRNAV airspace. Aircraft unable to maintain RNP-10 or BRNAV RNAV tolerances must advise controlling agency immediately and take appropriate coordinated action.

## Chapter 12

### FUEL PLANNING

**12.1. General.** A fuel plan is required for all flights except local area flights with established standard fuel loads. The Computer Flight Plan (CFP) and Performance Manual are the primary method of fuel planning. All preflight planning must be verified with aircraft mission computer (MC) performance prior to departure. (T-3) Missions should be planned at altitudes, routes and airspeeds to minimize fuel usage.

12.1.1. MC-130J Management. All MC-130J flight operations will use fuel planning and en route fuel management procedures. (T-2) **Note:** The flight planning computer configuration is approved by MAJCOM and the Special Operations Mission Planning Office. Uncertified, untested, or beta versions of developing software will not be used for actual mission planning. (T-2)

12.1.2. **CAUTION:** Critical fuel decisions should not be predicted on the information provided by the CNI-SP calculations alone. Performance Manual charts should be cross-checked before proceeding on a fuel critical course of action.

**12.2. Alternate Selection.** Plan fuel to an alternate only when AFI 11-202, Vol 3, or this manual require the filing of an alternate.

12.2.1. When only one alternate is required, use the closest suitable airfield meeting mission requirements (such as special requirements for hazmat or patients) and AFI 11-202, Vol 3, weather criteria.

12.2.2. If two alternates are required, use the two closest suitable airfields meeting AFI 11-202, Vol 3, weather criteria and fuel plan to the more distant of the two.

12.2.3. When selecting an alternate, suitable military airfields are preferred if within 100 NM of destination.

**12.3. Fuel Planning Profiles.** En route cruise airspeed should be planned at a constant TAS IAW the Performance Manual. Missions planned using Long Range Cruise (LRC) provide little flexibility in the air when faced with actual fuel critical situations requiring the conservation of additional fuel. Divert profiles should be fully fuel planned and represent what will actually be flown. Altitudes should be no higher than the ATC cruise ceiling per the Performance Manual or fuel freezing temperature limitations, whichever is lower.

12.3.1. CFP Planning Profile. The MC-130J performance module of Portable Flight Planning System (PFPS) (or follow on system) is certified to calculate accurate fuel planning information. Crews should use the C130JHI.frm or C130JHI.xls form when printing the CFP so both the route of flight and fuel planning information can be recorded. Use the fuel planning blocks on the top of the flight plan and **Figure 12.1** for fuel planning. (T-3) Pilots/CSO will ensure an accurate Recovery Fuel is input on the CFP Prepermission/Configuration/Fuel screen so calculated Continuation Fuels used during in-flight fuel monitoring are valid. (T-3) When alternates are required, crews may need to accomplish and print two iterations of the flight plan to incorporate an accurate Recovery Fuel. For example: after the first calculation, pilots will extract the en route fuel to the alternate from the last line of the flight plan and add this to the initial Recovery Fuel. A second flight plan will be calculated once the

Premission/Configuration/Fuel screen is updated with the correct Recovery Fuel. If an alternate is required, use the Turnpoint/Additional Points screen to insert the designated airfield as a DVT (divert) type after the intended landing airfield. See [Figure 12.1](#) for a sample of a completed PFPS CFP.

12.3.2. MC-130J Mission Computer Profile. The MC-130J Mission Computer plans a complete climb, cruise, descent, approach, and landing profile based on the inserted LEGS DATA and PERF CLIMB, CRUISE and DESCENT factors. Accurate leg fuels, as calculated by the Mission Computer, are dependent on crew ensuring that airspeed, altitude, winds, temperature, and fuel flow are correctly represented for each leg of the route and updated/corrected as in-flight conditions change. Because the flight profile is more than a planning tool, crews must use good judgment when inputting forecast/planned information versus actual performance and conditions. During preflight and at each waypoint, the Fuel On Board (FOB) for remaining legs will be compared against the flight planned Continuation Fuel to ensure there is sufficient fuel to continue the mission as planned in order to meet or exceed destination fuel requirements. (T-3) Once the flight plan is activated, the FOB on the PERF INIT WEIGHT page is calculated (not sensed) using sensed Fuel Flow over Time. The CNI will provide a FUEL QTY ERROR advisory when the PERF INIT WEIGHT FOB and totalizer readings differ by more than 2,500 lbs for more than 10 minutes. Reserve Fuel (FIXED on PERF INIT WEIGHT) should be set to the Recovery Fuel value. The CNI supplies a Low Calculated Fuel advisory when the calculated EXTRA fuel on the PERF INIT WEIGHT page falls below zero. Destination and Alternate Landing Fuel can be obtained from the MC. Flight crews will use the MC to evaluate and verify destination landing fuel status after mission changes and reroutes and whenever a divert airfield is required and/or extensive weather avoidance routing is required. (T-3)

**12.4. Fuel Planning Procedures.** Aircrew and mission planners will manage aviation fuel as a limited commodity and precious resource. (T-2) Fuel optimization will be considered throughout all phases of mission planning and execution. (T-3) Excessive ramp and recovery fuel adds to aircraft gross weight and increases fuel consumption. Do not ferry extra fuel beyond optimum requirements for safe mission accomplishment and training objectives. Aircrew and mission planners will optimize flight plans and flight routing for fuel efficiency. (T-3) In-flight procedures such as climb/descent profiles and power settings should also be considered for efficient fuel usage. Aircrew should employ aviation fuel optimization measures without compromising flight safety or jeopardizing mission/training accomplishment.

12.4.1. Routes should be planned at 320 KTAS (260 KTAS below 10,000 MSL), except for oceanic crossings.

12.4.2. For oceanic crossings, routes should normally be planned at Long Range Cruise (LRC) combined with a step-climb profile unless circumstances preclude otherwise. LRC airspeed is a function of altitude and gross weight, and subsequently corrected for Temp Dev and drag (Reference: Performance Manual: Specific Range Charts). For oceanic crossings, aircrew will ensure the leg fuel burn rates entered into the CNI-MS coincide with those on the flight plan, either via transfer card or manually input.

12.4.3. Using all available planning tools (including ACFP if feasible) and guidance in this chapter, PICs will approve the Required Ramp Fuel Load (RRFL).

12.4.4. Ensure ramp fuel is correct upon arrival at aircraft.

12.4.5. Minimize use of APUs. Use ground power units when practical.

12.4.6. Delay engine start time.

12.4.7. Minimize aircraft weight through optimized fuel loads and reduction of equipment not necessary to accomplish the mission.

12.4.8. Flight Plan Changes and Diversion. When mission requirements or ATC dictate a change to the planned mission or route, the fuel must be recalculated to ensure safe completion of the flight. (T-2) It is not practical to complete a new flight plan fuel log so the MC is the primary method of deciding if a mission change or reroute can be accommodated.

12.4.8.1. For an unplanned or directed en route divert, the FROM/TO page, with an associated cruise ground speed, can be used to determine an Estimated Time En route (ETE). Using a 4,500 lbs/hr or LRC speed from OPTIMAL CRZ 1/2 fuel burn, crews should be able to decide if the new routing is achievable without adverse effects on destination fuel. Do not accept a reroute that adversely depletes the destination Reserve Fuel as prescribed in this chapter.

12.4.8.2. If the en route change does not affect the intended destination, then in-flight fuel monitoring will consist of comparing the MC predicted Remaining Fuel with Flight Plan Continuation Fuel at the next point common to the reroute and the original flight plan. After any route alteration, crews should actively monitor fuel state by recording the Fuel Remaining values at abeam positions of the original flight plan and using the "Abeam" function of the INDEX/FIX INFO PAGE to cross-check fuel status.

12.4.9. Declare "**Emergency Fuel**" to ATC when it is determined that the aircraft will land with less than 3,000 lbs. (T-2)

12.4.10. Declare "**Minimum Fuel**" to ATC when it is determined that the aircraft will land with less than the calculated Recovery Fuel. (T-2) When Recovery fuel is entered into the CNI-MU on the PERF INIT WEIGHT page under FIXED, the aircraft provides a LOW CALCULATED FUEL advisory when extra fuel is zero or less.

Table 12.1. MC-130J Fuel Load Requirements.

1. EN ROUTE FUEL	<i>STTO</i>	A component of en route fuel. Fuel required for engine start, taxi and takeoff. Normally 800 lbs. For known taxi delays or additional engine running ground time in excess of 30 minutes, add 30 lbs/min.	R E Q U I R E D  R E C O V E R Y  R A M P  F U E L  L O A D
	<i>Climb</i>	A component of en route fuel. Fuel required from takeoff through climb to initial cruise altitude. If a manual calculation is required, the applicable Performance Manual's Fuel to Climb charts will be used. Unless required for mission accomplishment, plan to climb no higher than ATC cruise ceiling per the Performance Manual.	
	<i>Cruise</i>	A component of en route fuel. Fuel required from Top of Climb (TOC) to overhead intended destination. If a manual calculation is required, the applicable Performance Manual's charts will be used. (Include planned mission orbits ex SAR, EC-130J Broadcast orbit, etc)	
	<i>Appr</i>	A component of en route fuel. Fuel required for approach, and landing from overhead destination. Normally 700 lbs, which accounts for one instrument approach of no longer than 10 minutes. For longer approaches, follow-on visual, and/or radar pattern work, compute fuel burn at 85 lbs/min.	
2. EN ROUTE RESERVE	Fuel for 10% of en route time along a CAT I route/segment computed at terminal fuel flow, not to exceed 45 minutes of flight time.		
3. ALTERNATE  AND  MAP	<i>Alternate</i>	Fuel required from intended destination to alternate, or most distant alternate when two are required. Flown at optimum cruise altitude, using direct routing to the alternate at LRC airspeed.	
	<i>Missed Approach</i>	(2000lbs) Fuel for a missed approach and second approach at the alternate airfield. Entry only required when the visibility-only criteria is used to determine the suitability of the original destination	
4. HOLDING	Always plan a 45-minute fuel reserve at destination or alternate (if an alternate is required). Normally 3000lbs, or calculate using Four-Engine Maximum Endurance Fuel Flow at 20,000ft MSL.  For Remote or Island Destination holding in lieu of an alternate, use 8,000 lbs or 2+00 calculated at Four-Engine Maximum Endurance Fuel flow at 20,000 ft MSL. This allows for 1+15 holding time and +45 minutes reserve fuel.		
5. MIN LANDING	3,000 lbs (Always Required) If it is determined that the aircraft will land with less than this amount, a fuel emergency exists and ATC must be informed. This entry is separate from holding fuel reserves.		
6. IDENTIFIED EXTRA	<i>Wing Relieving Fuel</i>	Additional fuel kept in the main tanks intended to counter wing bending moments and keep the aircraft within flight manual weight limitations. Calculate Wing Relieving Fuel using the flight manual to ensure Recovery Fuel (item 10) does not fall below the fuel required to remain within limits.	
	<i>Depressurization Fuel</i>	Additional fuel burned from the ETP to a recovery airfield, with a 30 minute reserve at 10,000ft. Calculate at 1,000lbs per hour or using additional fuel burned at Four-Engine Long Range Cruise Fuel Flow at 10,000ft MSL. Plan on burning all fuel except RECOVERY FUEL (item 10). 3000lbs (45-minutes) of HOLDING (item 4) may be burned.  If additional fuel burned at 10,000ft is less than EN ROUTE RESERVE (item 2) plus 3,000lbs (45-minutes) of HOLDING (item 4), then no entry is required.  If additional fuel burned exceeds EN ROUTE RESERVE fuel (item 2) plus 3000lbs (45-minutes) of HOLDING fuel (item 4), then only add the difference here.	
	<i>Weather Avoidance</i>	1,500 lbs if forecast thunderstorms are scattered or numerous along the route of flight.	
	<i>Tankered Fuel</i>	Fuel for succeeding legs without refueling. (Only if required for next sortie or HAAR, FARP, etc for offload, if tankered fuel is not required, it may be included as unidentified extra)	
	<i>Icing</i>	1,000lbs if the route of flight has known or forecast icing conditions.	
7. REQUIRED RAMP	Required Ramp Fuel Load (RRFL). Minimum fuel required at engine start to complete tasked mission. Calculate by adding ENROUTE (item 1), EN ROUTE RESERVE (item 2), ALTERNATE & MAP (item 3), HOLDING (item 4), MIN LANDING (item 5) and IDENT EXTRA (item 6)		
8. ACTUAL RAMP	Actual ramp fuel load.		
9. UNIDENTIFIED EXTRA	Difference between REQUIRED RAMP FUEL LOAD (item 7) and actual ramp fuel.		
10. RECOVERY FUEL	The minimum planned landing fuel at intended destination. This is the sum of the ALTERNATE & MAP (item 3), HOLDING (item 4), <i>Wing Relieving Fuel (if required)</i> , and MIN LANDING (item 5). This fuel is critical to calculating accurate Continuation Fuels for each leg; it must be updated in the Pre-mission Configuration screen of the CFP. This value should be set in the CNI-MU on the PERF INIT WEIGHT page under FIXED (Defined in TO as "Reserve Fuel").		

Figure 12.1. Master Flight Plan with Example Annotations (not for flight).

CFPS VERSION: 4.2 FOR THE MC-130J      NAVAID FLIP: 16 AUG 18      DATE SPUN: 201809050934

MISSION DATE	1. ENROUTE FUEL (STTO, CLIMB, CRUISE, APPR)	49695	COMPASS DEVIATION CHECKS				GROSS NAVIGATION ACCURACY CHECK		ATC CLEARANCES/FREQUENCIES					
CALL SIGN	2. ENROUTE RESERVE	3150	TIME	INS1	INS2	DEV	STBY	TIME 00:15		CAF RJSM 14722K © Oceanic HF1322 Sq 2247				
AIRCRAFT CDR	3. ALT & MAP (2000)		0022	253	254	-1	250	NAVAID AEO						
FROM: ELMENDORF AFB	4. HOLDING (3000/4500)	3000	ETP INFORMATION		IDENT	T IN HRS (ETP to FSAF) = DIST (LSAF to FSAF)				2563 (BF2-WF1) + 2TAS (-50+30)*2(290) = 4+34				
TO: MISAWA AB	6. IDENTIFIED EXTRA		LSAF	PAGE	DIST	TIME	DIST (ETP to FSAF) = T * GS (2ND HALF)							
TOT DISTANCE 2826	8. ACTUAL RAMP	60000	COAST-OUT WAYPT	BET	263	1129	GS	TAS	DIST (ETP to FSAF) = T * GS					
TOT ETE 10:48	9. UNIDENTIFIED EXTRA	555	APPROX MIDPOINT	OLCOT	1577	4:38	260	290	-30	WF1	WF = GS - TAS			
PARKING LOCATION:	10. CFPS RECOVERY FUEL (3-4-5)	4000	COAST-IN WAYPT	RJSM	1563	4:19	240	290	-50	WF2	ETP = 4134			
TAKEOFF GROSS WEIGHT 162200			PLANNED RAMP FUEL 60000			ETP DIST = 1,097 NM								

#	ROUTE FIX	BANK CHNL FREQ	LAT LONG	MC DRIFT MH	ZD TD TDR	ALT W/V SAT	IN FLIGHT WEATHER	IAS TAS GS	ZT TT TTR	ETA RETA ATA	MIN A/B	LEG FUEL REM FUEL F FLOW	ACTUAL CONT F EXCESS	INAV1	INAV2
⊗	PAED/A ELMENDORF AFB		N 61 15.08 E149 48.39	062 0 062	0 0 2826	213M +15C			00:00 00:00 10:48	00:00	A/B	800 59200	52895		BRG/RNG
⊗	BGO/R BIG LAKE	30T 072X 112.50	N 61 34.17 E149 58.03	330 0 330	19 19 2807	10356M 270/030 -6C		N/A N/A N/A	00:06 00:06 10:42	00:06	A/B	825 58375 8183	52070		BRG/RNG
⊗	YONEK/W YONEK	30T	N 61 10.38 E151 14.14	221 0 221	43 61 2764	21649M 270/030 -28C		N/A N/A N/A	00:11 00:17 10:30	00:17	A/B	1308 57067 6699	50762		BRG/RNG
	level off		N 61 10.38 E151 18.46	254 0 254	2 63 2762	22000M 270/030 -29C		N/A N/A N/A	00:00 00:18 10:29	00:18	A/B	52 57015 6699	50710		BRG/RNG
⊗	ORTE ORTE	30T	N 61 10.25 E151 55.60	254 0 254	18 81 2744	22000M 270/030 -29C		208 290 260	00:04 00:22 10:25	00:22	A/B	335 56680 4845	50375		BRG/RNG
⊗	BQA J501 SPARREVOHN	30T 119X 117.20	N 61 05.91 E155 38.07	254 0 254	108 189 2636	22000M 270/030 -29C		208 290 260	00:24 00:47 10:00	00:47	A/B	2002 54678 4821	48373		BRG/RNG

C-130J HIGH LEVEL FLIGHT PLAN

#	ROUTE FIX	BANK CHNL FREQ	LAT LONG	MC DRIFT MH	ZD TD TDR	ALT W/V SAT	IN FLIGHT WEATHER	IAS TAS GS	ZT TT TTR	ETA RETA ATA	A/B	LEG FUEL REM FUEL F FLOW	ACTUAL CONT F EXCESS	BRG/RNG
✓	WAZEN K080 OGDEN	30T	N 49 29.21 E161 02.26	241 3 244	156 1799 1027	22000M 270/030 -29C		208 290 264	00:35 06:54 03:53	06:54	A/B	2575 26791 4359	20486	BRG/RNG
✓	OMOTO R580 OMOTO	30T	N 48 59.71 E160 00.65	239 3 243	50 1849 977	22000M 270/030 -29C		208 290 265	00:11 07:06 03:41	07:06	A/B	818 25973 4336	19668	BRG/RNG
✓	OPULO R580 OPULO	30T	N 45 31.86 E153 43.20	239 4 242	330 2179 646	22000M 270/030 -29C		208 290 265	01:14 08:21 02:27	08:21	A/B	5351 20622 4297	14317	BRG/RNG
✓	ONEMU R580 ONEMU	30T	N 41 44.37 E148 13.04	235 4 239	330 2509 316	22000M 270/030 -29C		208 290 267	01:14 09:35 01:12	09:35	A/B	5241 15381 4235	9076	BRG/RNG
✓	RJSM/A MISAWA AB	30T	N 40 42.19 E141 22.10	268 1 269	316 2826 0	22000M 270/030 -29C		208 290 260	01:12 10:48 00:00	10:48	A/B	5076 10305 4180	4000	BRG/RNG

C-130J HIGH LEVEL FLIGHT PLAN



#	ROUTE FIX	BANK CHNL FREQ	LAT LONG	MC DRIFT MH	ZD TD TDR	ALT W/V SAT	IN FLIGHT WEATHER	IAS TAS GS	ZT TT TTR	ETA BETA ATA	A/B	LEG FUEL REM FUEL F FLOW	ACTUAL CONT F EXCESS	BRG/RNG
⊗	VDDA J501 VDDA	30T	N 60 52.68 W160 28.55	253 0 253	142 331 2494	22000M 270/030 -29C		208 250 260	00:32 01:20 00:28	01:20	A/B	2609 52069 4776	45764	BRG/RNG
⊗	BET J501 BETHEL	30T 088X 114.18	N 60 47.09 W161 49.46	250 1 251	40 371 2454	22000M 270/030 -29C		208 290 260	00:09 01:29 00:18	01:29	A/B	729 51340 4744	45035	BRG/RNG
⊗	ORVIL ORVIL	30T	N 59 30.82 W167 32.45	237 2 239	188 559 2266	22000M 270/030 -29C	22000M 280/29 -29	208 290 262	00:43 02:12 00:35	02:12 01:50	A/B 22	3372 41063 4706	41060 +337	BRG/RNG 073/0.1
⊗	ONEOX R500 ONEOX	30T	N 58 46.81 W171 19.01	242 2 244	125 684 2141	22000M 270/030 -29C	22000M 270/31 -29	208 290 262	00:28 02:41 00:07	02:41 02:18	A/B 23	2225 45743 4654	40000 39438 +962	BRG/RNG 075/0.25
⊗	OGGOE R500 OGGOE	30T	N 58 17.13 W173 34.97	242 2 244	77 761 2065	22000M 270/030 -29C	22000M 277/210 -29	208 290 262	00:17 02:58 07:49	02:58 02:33	A/B 25	1358 44385 4621	39000 38080 +920	BRG/RNG 080/0.4
⊗	OFORD R500 OFORD	30T	N 57 32.18 W176 48.08	242 2 244	112 874 1952	22000M 270/030 -29C	22000M 277/29 -29	208 290 262	00:25 03:24 07:23	03:24 02:59	A/B 25	1970 42415 4591	37500 36110 +1390	BRG/RNG 090/0.8
⊗	OBOYD R500 OBOYD	30T	N 56 03.95 E177 58.71	241 3 243	194 1067 1759	22000M 270/030 -29C		208 290 263	00:44 04:08 06:30	04:08	A/B	3351 39054 4547	32750	BRG/RNG
⊗	ONEIL R500 ONEIL	30T	N 54 12.15 E172 40.85	239 3 242	214 1281 1545	22000M 270/030 -29C		208 290 263	00:48 04:57 05:50	04:57	A/B	3648 35416 4492	29111	BRG/RNG
⊗	49SYA R500 SYA/R279149	30T 027X 109.00	N 53 03.00 E170 00.00	235 3 239	118 1399 1426	22000M 270/030 -29C		208 290 265	00:26 05:24 05:24	05:24	A/B	1985 33431 4449	27126	BRG/RNG
⊗	OPAKE R500 OPAKE	30T	N 53 00.07 E169 53.57	235 4 238	5 1404 1422	22000M 270/030 -29C		208 290 265	00:01 05:25 05:22	05:25	A/B	81 33350 4434	27045	BRG/RNG
⊗	OLCOT R500 OLCOT	30T	N 51 25.81 E165 33.34	243 3 246	186 1590 1236	22000M 270/030 -29C		208 290 263	00:42 06:07 04:40	06:07	A/B	3111 30239 4411	23034	BRG/RNG
⊗	OPHET R500 OPHET	30T	N 50 57.45 E164 22.89	241 3 244	53 1642 1183	22000M 270/030 -29C		208 290 264	00:12 06:19 04:28	06:19	A/B	873 29366 4382	23061	BRG/RNG

C-130J HIGH LEVEL FLIGHT PLAN

**12.5. Air to Air Refueling Fuel Planning Procedures.** When the mission includes in-flight refueling (single or double AAR), crews should use the AF Form 4139J **Figure 12.2** in conjunction with the approved CFP to perform the fuel analysis. With the exception of those items identified on the AF Form 4139J, all items are outlined in **Table 12.1**

12.5.1. **Abort Fuel Planning.** An abort base is required for all refueling tracks. The departure base may be used. The designated abort base must meet alternate airfield weather requirements IAW AFI 11-202, Vol 3. All route segments, which include an in-flight refueling, should be planned with sufficient fuel onboard to fly from the departure airfield or previous End Air Refueling point (EAR) to an EAR point, and if required, divert so as to arrive overhead the abort airfield with sufficient fuel to hold, accomplish a descent/approach and land with Required Recovery Fuel (Item 10) without receiving an on-load. **Note:** Air refueling divert entries and fuel on-loads should be entered in the EAR waypoint line.

12.5.2. If AAR is required, multiple iterations of the flight plan will need to be printed. A singular flight plan for every segment of the flight (i.e., “T/O to EAR #1 to DVT”, “ARIP #1 to EAR #1 to Dest”) will be needed. (T-3) In order to get accurate Continuation Fuel on the CFP, use the following process. Crews may optionally use a single consolidated flight plan to conduct the AAR fuel iterations.

12.5.2.1. The initial segment flight plan will include all waypoints from takeoff through the Air-to-Air Refueling Exit Point (AREP), then routing to the AAR #1 Abort Base. (T-3)

12.5.2.2. Do not include any tanker onloads on this flight plan.

12.5.2.3. Create a second flight plan starting with the Air-To-Air Refueling Initial Point (ARIP). This flight plan will include all waypoints from the ARIP through the destination. (T-3)

12.5.2.4. Include a tanker onload at the AREP.

12.5.2.5. Perform similar iterations if more than one AAR is required.

Figure 12.2. AF FORM 4139J

SPECIAL OPERATIONS C-130J INFLIGHT REFUELING WORKSHEET									
AIRCRAFT #:		(A) OPERATING WT:			(C) PLANNED ONLOAD AIR #1:			NOTES ASSOCIATED WITH SPECIFIC ITEM NUMBERS	
AIRCRAFT CONFIG:		(B) REQUIRED RAMP FUEL LOAD:			(D) PLANNED ONLOAD AIR #2:			ITEM 1: EXCLUDES APPROACH FUEL. ITEM 6: EXCLUDES STTO, BUT INCLUDES APPR (NORMALLY TOOLBS) ITEM 15: INITIAL FLIGHT PLANNED RAMP FUEL WITH AIR ITEM 17: (IF NEGATIVE) FUEL MUST BE ADDED TO THE RREFL (B) ITEM 26: EXCLUDES STTO, BUT INCLUDES APPR (NORMALLY TOOLBS) ITEM 35: (IF NEGATIVE) FUEL MUST BE ADDED TO THE RREFL (B), OR AIR #1 ONLOAD ITEM 46: (IF NEGATIVE) FUEL MUST BE ADDED TO THE RREFL (B), AIR #1 OR AIR #2	
<b>TAKEOFF TO EAR #1</b>					<b>EAR #1 TO EAR #2</b>				
T.O. GROSS WT (A + B - STTO):		FUEL PLAN PAGE:			EAR #1 GROSS WT (A + T):		FUEL PLAN PAGE:		
TEMP DEV:		TIME			TEMP DEV:		TIME		
1. EN ROUTE FUEL* (STTO, CLMB & CRUISE TO EAR #1)		FUEL			19. EN ROUTE FUEL* (CLMB & CRUISE TO EAR #2)		FUEL		
2. IDENTIFIED EXTRA (TAKEOFF TO EAR #1)					20. IDENTIFIED EXTRA (EAR #1 TO EAR #2)				
3. BURNOFF (1 + 2)					21. BURNOFF (19 + 20)				
4. EN ROUTE RESERVE (CAT I RESERVE TO EAR #1)					22. EN ROUTE RESERVE (CAT I RESERVE EAR #1 TO EAR #2)				
5. TOTAL (3 + 4)					23. TOTAL (21 + 22)				
6. FUEL AT EAR #1 (NO ONLOAD) (8 - 5)					24. FUEL AT EAR #2 (NO ONLOAD) (7 - 22)				
7. PLANNED EAR #1 FUEL (8 + C)					25. PLANNED EAR #2 FUEL (24 + D)				
<b>EAR #1 TO AIR #1 ABORT BASE</b>					<b>EAR #2 TO AIR #2 ABORT BASE</b>				
EAR #1 GROSS WT (A + 6):		FUEL PLAN PAGE:			EAR #2 GROSS WT (A + 24):		FUEL PLAN PAGE:		
TEMP DEV:		TIME			TEMP DEV:		TIME		
8. EN ROUTE FUEL* (EAR #1 TO ABORT BASE)		FUEL			26. EN ROUTE FUEL* (EAR #2 TO ABORT BASE)		FUEL		
9. EN ROUTE RESERVE (CAT I RESERVE: EAR TO ABORT BASE)					27. EN ROUTE RESERVE (CAT I RESERVE: EAR TO ABORT BASE)				
10. ALTERNATE & MAP (AR #1 ABORT BASE)					28. ALTERNATE & MAP (AR #2 ABORT BASE)				
11. HOLDING: (AR #1 ABORT BASE)					29. HOLDING: (AR #2 ABORT BASE)				
12. MIN LANDING FUEL: (3,000LBS)					30. MIN LANDING FUEL: (3,000LBS)				
13. IDENTIFIED EXTRA (EAR #1 TO ABORT BASE)					31. IDENTIFIED EXTRA (EAR #2 TO ABORT BASE)				
14. FUEL REQUIRED: (8+9+10+11+12+13)					32. FUEL REQUIRED: (26+27+28+29+30+31)				
15. PLANNED RAMP FUEL (SEE NOTE)					33. PLANNED EAR #1 FUEL (7)				
16. REQUIRED RAMP FUEL: (5 + 14)					34. REQUIRED RAMP FUEL: (23 + 32)				
17. UNIDENTIFIED EXTRA (15 - 16)					35. UNIDENTIFIED EXTRA (33 - 34)				
18. RECOVERY FUEL: (10 + 11 + 12 + WING RELIEVING)					36. RECOVERY FUEL: (28 + 29 + 30 + WING RELIEVING)				
<b>EAR TO DESTINATION</b>					<b>EAR TO DESTINATION</b>				
EAR GROSS WT (A + 7 OR A + 25):		FUEL PLAN PAGE:			EAR GROSS WT (A + 7 OR A + 25):		FUEL PLAN PAGE:		
TEMP DEV:		TIME			TEMP DEV:		TIME		
37. EN ROUTE FUEL* (EAR TO DESTINATION)		FUEL			37. EN ROUTE FUEL* (EAR TO DESTINATION)		FUEL		
38. EN ROUTE RESERVE (CAT I RESERVE: EAR TO DESTINATION)					38. EN ROUTE RESERVE (CAT I RESERVE: EAR TO DESTINATION)				
39. ALTERNATE & MAP (DESTINATION)					39. ALTERNATE & MAP (DESTINATION)				
40. HOLDING: (DESTINATION)					40. HOLDING: (DESTINATION)				
41. MIN LANDING FUEL: (3,000LBS)					41. MIN LANDING FUEL: (3,000LBS)				
42. IDENTIFIED EXTRA (EAR DESTINATION)					42. IDENTIFIED EXTRA (EAR DESTINATION)				
43. FUEL REQUIRED: (37+38+39+40+41+42)					43. FUEL REQUIRED: (37+38+39+40+41+42)				
44. LAST PLANNED ONLOAD: (C/D)					44. LAST PLANNED ONLOAD: (C/D)				
45. PLANNED EAR FUEL: (6/24)					45. PLANNED EAR FUEL: (6/24)				
46. REQUIRED EAR FUEL: (43 - 44)					46. REQUIRED EAR FUEL: (43 - 44)				
47. UNIDENTIFIED EXTRA (45 - 46)					47. UNIDENTIFIED EXTRA (45 - 46)				
48. RECOVERY FUEL: (39 + 40 + 41 + WING RELIEVING)					48. RECOVERY FUEL: (39 + 40 + 41 + WING RELIEVING)				
SIGNATURE: _____					DATE: _____				

AF FORM 4139J, 20180718, V1

PAGE 1 OF 1 PAGES



## Chapter 13

### LOADMASTER PROCEDURES

**13.1. General.** The loadmaster (LM) coordinates loading or offloading with air terminal operations or shipping agencies; plans loads; supervises loading, tie-down, and offloading operations; performs preflight and post flight of aircraft and systems; computes aircraft weight and balance; provides for the safety and comfort of passengers/troops and security of cargo during flight; prepares and rigs equipment for airdrop; participates in the aerial delivery of equipment, supplies, and personnel. In addition to the duties listed in the flight manual, other applicable technical orders, tactical manuals and this manual, the PIC may assign other mission-related duties as necessary.

#### **13.2. Aircraft Loading Responsibilities.**

13.2.1. The LM coordinates with the loading crew supervisor to verify cargo against manifests, supervises loading operations, and is responsible for the safe movement of cargo into and out of the aircraft. The LM will notify the PIC, command post, or the terminal operations officer if loading personnel are injured or cargo, aircraft equipment or aircraft structure is damaged during loading or offloading. (T-3) The LM will brief the PIC on any hazardous cargo and cargo jettison ability prior to engine start. (T-3)

13.2.2. Loads planned by qualified load planners will be accepted by the aircraft LM and loaded aboard the aircraft as planned, unless the load or any portion of it will compromise flight safety or does not comply with applicable aircraft technical orders or AF publications. (T-3) The aircraft LM may also deviate from load plans to facilitate ease of onload or offload of cargo and to alleviate unnecessary aircraft reconfiguration.

13.2.3. Some loads are not specifically detailed in applicable directives and require the LM to use their best judgment, based on training, experience, and knowledge, to determine the best and safest method of loading the cargo. When difficulties arise, they should seek advice of other personnel (i.e., available LMs and squadron, group, wing or MAJCOM standardization personnel.)

13.2.4. At locations without air terminal or traffic personnel, the shipper assumes the responsibility for ensuring cargo is properly weighed, marked and is accompanied by the correct documentation.

13.2.5. During AF mobility, exercise and contingency missions, the LM may accept DD Form 2133, *Joint Airlift Inspection Record*, as a valid pre-inspection of equipment being offered for air shipment. This form, validated by two joint inspection signatures (user and transporting force), may be used in lieu of the applicable portions of the TO 1C-130J-9CL-1. The DD Form 2133 will not be used to document preparation of hazardous materials. (T-3) This will be accomplished using the Shipper's Declaration for Dangerous Goods. (T-3)

**13.3. Emergency Exits and Safety Aisles.** Safety aisles will be maintained IAW AFMAN 11-2EC/MC-130J, Vol 3, Addenda A, *E/MC-130J Operation Configuration/Mission Planning* and this chapter. (T-2)

**13.4. Flight Monitoring.** The loadmaster will monitor all applicable aircraft systems. (T-3) Notify the PIC of all abnormal indications and take appropriate action.

**13.5. Weight and Balance.** Accomplish weight and balance according to TO 1-1B-50, Weight and Balance, TO 1C-130J-5-1, Sample Basic Weight Checklist, TO 1C-130J-5-2, Loading Data Manual, and AFMAN 11-2EC/MC-130J, Vol 3, Addenda A. The unit possessing the airplane maintains the primary weight and balance handbook containing the current airplane status and provides a supplemental weight and balance handbook for each airplane. Enclose the supplemental handbook in a wear-resistant binder (preferably metal), stenciled "Weight and Balance" with the airplane model and complete serial number on the cover or spine.

13.5.1. The supplemental handbook will include TO 1C-130J-5-1, TO 1C-130J-5-2, and the AFMAN 11-2EC/MC-130J, Vol 3, Addenda A, sufficient copies of DD Form 365-4, to complete the mission and a certified copy of the current DD Form 365-3, *Chart C-Basic Weight and Balance Record*. The Chart C will include the airplane's basic weight, basic moment and center of gravity. (T-2)

13.5.2. Compute weight and balance either using the Chart E mathematical (moments) method via the CNI-MU or approved Automated Form F (AFF) software. Compute DD Form 365-4 IAW AFMAN 11-2EC/MC-130J, Vol 3, Addenda A, and 1C-130(M)J-9, *Cargo Loading Manual*. Presently AFF software does not accommodate the MC-130J airframe. If used, Center of Gravity limits for takeoff and landing must be physically checked against TO 1C-130(M)J-5. (T-3) Estimated landing fuel function will also be used as software does not support Tanker AAR, Receiver AAR, and present fuel burn rates. These items will be annotated in the additional remarks block of the AFF. (T-3) Two copies will be printed, one will remain onboard until mission termination, make every attempt to leave the other copy with air terminal/maintenance personnel remaining on the ground. (T-3)

13.5.3. The weight and balance section of the unit possessing the airplane will maintain the required documents. (T-3)

**13.6. Air Cargo Restraint Criteria.** Restrain cargo in accordance with TO 1C-130J-9, *Cargo Loading Manual* or AFTTP 3-3.E/MC-130J, and **Attachment 2** of this manual during Infil/Exfil operations.

**13.7. Mission Equipment Requirements.** The loadmaster(s) will ensure the following equipment is aboard the aircraft when required for off-station missions. (T-3) Note: Units should specify additional mission equipment requirements in unit supplements to **Chapter 10** of this manual. Additionally, units may add to contents of the kits described below.

13.7.1. Aerial Delivery Kits. The aerial delivery will include sufficient quantities of: Type III nylon (550 cord), Type I (80 lb) (1/4" cotton webbing), Ticket 8/7 (5 cord), both IR and overt chemical lights, cloth backed tape, and 0.032 diameter steel safety wire. (T-3)

13.7.1.1. CDS Kit. Units will determine contents of this kit. However, it will contain a minimum of four Van Zelm ratchets and sufficient quantities of items to conduct drops at each pulley location. (T-3)

13.7.2. Blackout Kit/Rapids Kit. The kit will include a minimum of: sufficient quantities/sizes of IR and overt chemical lights, cloth backed tape, blackout covers and a sufficient quantity of 1,000 lb nylon. (T-3)

13.7.3. Bi-Fold Auxiliary Ramps. If bi-fold auxiliary ramps (canary slides) are not available, deploy with four auxiliary ground loading ramps per aircraft. (Some specific missions may require five per aircraft).

13.7.4. Miscellaneous Supplies. Loadmasters will ensure that sufficient quantities of airsickness bags, earplugs, insecticide, etc., are carried as mission dictates. (T-3)

13.7.5. Miscellaneous Equipment. Loadmasters will ensure those items required by AFMAN 11-2EC/MC-130J V3, Addenda A, are on board for the mission(s) being conducted while off-station. (T-3)

### **13.8. Channel Cargo and Passenger Missions.**

13.8.1. Channel Cargo. MC-130J aircraft do not routinely airlift channel cargo; however, if so tasked, contact the Air Terminal Operations Center (ATOC), Airlift Control Element (ALCE), or air freight/passenger service to obtain the cargo and passenger breakdown and assist in planning of proposed load. If required, security requirements for the cargo/passengers will be briefed to the loadmaster during the initial load briefing at ATOC. (T-3) At stations where aircraft tie-down equipment is exchanged, make every effort to ensure that a one-for-one exchange occurs. If this is not possible, the loadmaster will inform the PIC of lost or missing equipment and annotate missing items on the aircraft Dash 21 Equipment Inventory, refer to AFTO Form 781. (T-3)

13.8.2. Passenger Missions.

13.8.2.1. MC-130J aircraft will not normally be tasked to support Air Mobility Command passenger missions, nor will passengers be manifested or loaded aboard MC-130J aircraft without the prior approval of the PIC/mission commander.

13.8.2.2. Prior to releasing seats, ensure terminal operations passenger handling personnel are aware that passenger comfort latrine facilities are extremely limited, and of the possibility of an in-flight diversion.

### **13.9. Passenger Handling.**

13.9.1. Passengers may move about the cargo compartment. Good judgment must be exercised on the number of passengers allowed out of their seats at one time. Encourage passengers to keep seat belts fastened when seated.

13.9.2. Do not allow passengers to lounge on or tamper with equipment, cargo or baggage. Ensure passengers are not allowed access to checked baggage.

13.9.3. Ensure that classified equipment remains covered during the entire mission when passengers are onboard and ensure passengers are denied access to this equipment. (T-3)

**13.10. Troop Movements.** Most personnel carried aboard MC-130J aircraft are aboard to perform a specific mission. Every effort should be made to advise them of mission progress and deviations. The troop commander will be identified prior to boarding. (T-3)

13.10.1. Determine if the troop commander has any special requirements prior to departure, and advise the PIC of these requirements, if appropriate.

13.10.2. Determine if specific communications requirements exist and coordinate these requirements with the PIC.

13.10.3. Determine if there is a need for the troops to perform any type of in-flight rigging. Ensure the aircraft is loaded to accommodate in-flight rigging if required. Inform the PIC prior to in-flight rigging. If turbulence is anticipated, the PIC should inform the loadmaster as much in advance as possible.

13.10.4. Ensure that troops do not have access to aircraft classified equipment during the mission. (T-3) If troops require access to classified equipment, the requirement should be made known to the PIC prior to the mission.

13.10.5. Passenger Combat Loading. Floor loading is authorized to support dedicated unconventional forces and foreign counterparts during operations, exercises and training. Standard seating configurations listed in applicable addenda should be used, if practical. **Exception:** Group commander (COMAFSOF for contingency operations) may authorize Rapid Infil/Exfil procedures and floor loading with non-SOF personnel. **Note:** This procedure will not be used in lieu of providing normal seating when available. (T-3) **WARNING:** During passenger combat loading, the loadmaster will ensure all occupants are provided restraint IAW AFTTP 3-3.E/MC-130J . (T-3) At no time shall the number of combat-loaded personnel exceed five across per row. (T-3) The loadmaster shall not exceed the aircraft's maximum allowable gross weight or center of gravity limitations. Passenger weights will be calculated IAW AFMAN 11-2EC/MC-130J Vol 3 Addenda A, Table 4.1 Standard Weights. (T-2)

13.10.6. All personnel in the cargo compartment will be seated and secured except those crew members having valid duties to perform. (T-3)

13.10.7. Combat Offload Training. No special authorization is required for combat offload training using unilateral training loads.

**13.11. Border Clearance.** Customs, Immigration and Agriculture require certain forms for border clearance. The loadmaster will ensure that required forms are contained in the aircraft mission kit. (T-3) Distribute the forms to the crew and ensure their completion prior to landing; deliver them to the proper persons. Also comply with the requirements of this manual.

**13.12. Hostile Environment Operations.** Remove all non-essential equipment from the aircraft prior to a combat mission. Hostile Environment Repair Procedures (HERP), tool kit requirements can be found in AFSOCMAN 11-201. Each individual tail number requires a separate HERP tool kit that shall be carried onboard the aircraft for all sorties. (T-3) AFSOCMAN 11-201 currently lists HERP, however crews will conduct procedures IAW guidance contained in TO 1C-130(M)J-1, Section 5. (T-2)

**13.13. Rapid Infiltration/Exfiltration (“Rapids”).** Refer to [Attachment 2](#) of this manual.

**13.14. Combat Offload.** Refer to [Attachment 4](#) of this manual.

**13.15. FARP.** Refer to [Attachment 3](#) of this manual.



## Chapter 14

### ELECTRONIC WARFARE PROCEDURES

**14.1. General.** In addition to the duties listed in the flight manual, other directives and this manual, the PIC may assign other duties as necessary. The MC-130J CSO is primarily responsible for aircraft defense by denying the enemy effective use of the electromagnetic spectrum.

14.1.1. Mission Planning Equipment. Pilots and CSOs must be capable of using their unit's primary computerized mission planning system, as well as basic radar coverage formulas, graphs, and nomograms. (T-3)

14.1.2. Mission Planning Factors. Detailed information on threat mission planning can be found in AFTTP 3-1.General Planning (S), *Tactical Employment General Planning*; AFTTP 3-1.Threat Guide (S), *Threat Reference Guide and Countertactics*; and AFTTP 3-1.E/MC-130J, *Tactical Employment E/MC-130J*.

14.1.3. Mission Charts. The CSO will prepare mission charts IAW this publication (see [Chapter 17](#)). (T-3) In addition, the charts will include the location and lethal threat range rings (shadow graphing as required) of all threat systems which could affect aircraft survivability or mission completion. (T-3)

14.1.3.1. For missions scheduled with Electronic Countermeasures (ECM) training. The CSO or pilot will brief all applicable procedures, rules of engagement, and anticipated maneuvers. (T-3)

14.1.3.2. On training missions with Airborne Intercepts (AI) training. The CSO or pilot will brief all applicable procedures, rules of engagement, and anticipated maneuvers. (T-3) Coordinate AI training IAW AFI 11-214, *Air Operations Rules and Procedures*.

14.1.3.3. For tactical training missions not involving ECM or AI training, a threat of the day will be briefed. (T-3)

#### 14.2. In-Flight Responsibilities.

14.2.1. CSO or Pilot will verify aircraft electronic warfare configuration. (T-3) Aircraft ECM and infrared countermeasure configuration will be commensurate with the threat. (T-2) Ensure appropriate databases/Mission data Files (MDFs) are loaded into all defensive systems, depending on geographical locations or electronic order of battle. (T-2) See MDS specific technical orders and system handbooks for most current system information.

14.2.2. During the low-level portion of the mission, immediately following the leg briefing, the CSO will brief the anticipated threats and aircraft deviations prior to a threat leg. (T-3)

14.2.3. The CSO or pilots will notify and/or warn the crew if threats are encountered. (T-3)

14.2.4. The PF or CSO will direct defensive maneuvers and perform ECM as appropriate. (T-3) Brief/update ECM effectiveness when it can be determined throughout defensive maneuvers.

14.2.5. The CSO or PM will notify crew of defensive system malfunctions and affect(s) on mission accomplishment and tactics. (T-3) Keep crew updated on chaff/flare status.

14.2.6. The CSO will advise the crew upon entering/exiting the hostile environment. (T-3)



## Chapter 15

### COMMUNICATIONS

**15.1. General.** The PIC is responsible for ensuring the proper programming, management, operation and in-flight troubleshooting of communications, navigation, IFF/SIF and specialized mission equipment. In addition to the duties listed in the flight manual, other applicable technical orders, and this manual, the PIC may assign other duties to the crew as necessary. This chapter provides guidance on crew procedures for all missions and completion of applicable forms.

15.1.1. The crew will tune, configure, operate and troubleshoot voice and data communications systems and manage communications nets to support mission requirements; recommend and make required communications changes; compile and transmit required in-flight and position reports to appropriate facilities; and coordinate, obtain, use, and control COMSEC/Transmission Security material and equipment. (T-3)

15.1.2. Frequencies and Call Signs. The crew will review the ATO prior to each flight when deployed or during exercise participation; additionally, review at a minimum Special Instructions (SPINS) **Chapters 2, 3, and 7**. Use current FLIPs, In Flight Guides (IFGs), and other documents and publications for frequency use as required, which may be obtained at <https://aerodata.nga.mil/AeroBrowser/>. (T-3) Identify communications and available services at the designated emergency airfields. Obtain aircraft type(s) and call signs for all aerial refueling operations; check IFGs and applicable DoD FLIP Area Planning Publications for AAR track information as required.

15.1.3. Communications Threat Planning. When deployed or during exercise participation, the crew will obtain information on enemy systems that can effect communications, navigation, and IFF equipment in the mission area. (T-3) **Note:** HAVE QUICK II and Single Channel Ground and Airborne Radio System (SINCGARS) anti-jam capability are not secure and will not be used for classified transmissions unless in conjunction with a secure voice system. (T-3)

15.1.4. Special Use Airspace. When planned flying in Warning Areas, Military Operating Areas, Restricted Areas or ATC assigned working areas, the crew will contact the controlling station during mission planning and confirm timing, scheduled activity and communication procedures to the extent possible. (T-3) The PIC will brief any conflicts or issues that could affect the mission. (T-3)

15.1.5. COMSEC. The PIC will ensure the crew reviews the COMSEC Call Out or other applicable documents as soon as possible to ensure the correct materials are available or ordered in time for the mission. (T-3) Maintain positive control of all COMSEC material and document safe inventory, complete daily destruction and issue current COMSEC material IAW COMSEC instructions, supplements and Operating Instructions as required. The PIC will ensure the appropriate crew member is assigned responsibility for the security of classified mission documents and software for equipment as required or directed. (T-3)

## Chapter 16

### DIRECT SUPPORT OPERATOR PROCEDURES

**16.1. General.** This chapter establishes procedures for MC-130J Direct Support Operators (DSO) for employment of MC-130J aircraft. In addition to the duties listed in applicable technical orders, directives, and this manual, the PIC may assign other duties as necessary. The DSO is primarily responsible for providing inputs to enhance aircrew situational awareness.

#### **16.2. Mission Planning Factors.**

16.2.1. Mission Planning. Detailed information on mission planning can be found in AFTTP 3-1.General Planning(S), *Tactical Employment General Planning*, AFTTP 3-1.Threat Guide, *Threat Reference Guide and Countertactics*, AFTTP 3-1.E/MC-130J, *Tactical Employment E/MC-130J*, and AFTTP 3-3.E/MC-130J, *Combat Aircraft Fundamentals E/MC-130J*.

16.2.2. The DSO, after coordinating with the supporting analyst and other appropriate agencies, will conduct mission planning with the aircrew of all combat mission scenarios. (T-3) The DSO will brief expected scenario inputs based on the analytical data, as required. (T-3)

16.2.3. The DSO is responsible for coordinating with all appropriate agencies to obtain all required or anticipated mission planning, professional, and JOINT THREAT WARNING SYSTEM equipment for the duration of the flight/deployment. The DSO will ensure all equipment is inventoried and inspected prior to flight/deployment. (T-3)

#### **16.3. Preflight/In-Flight Responsibilities.** The DSO will:

16.3.1. Brief the crew on the JOINT THREAT WARNING SYSTEM / JTWS-Air equipment configuration and anticipated inputs. (T-3)

16.3.2. Ensure the crew is aware of JOINT THREAT WARNING SYSTEM / JTWS-Air capabilities and limitations, as well as operational security considerations. (T-3)

16.3.3. Monitor situational awareness information and relay pertinent information to the crew. (T-3)

16.3.4. Advise the crew of any change in the status of mission equipment.

16.3.5. The DSO is responsible for knowing approximate aircraft location, altitude and intentions at all times. (T-3)

16.3.6. Be co-located with the JOINT THREAT WARNING SYSTEM / JTWS-Air equipment, unless mission requirements call for alternate seating location. (T-3)

**16.4. Communications Procedures.** When missions require the DSO to communicate, they will obtain proper frequencies, time hack, schedules and call signs prior to flight. (T-3) Depending on the nature of the mission and the communications, the DSO will keep the crew updated on any pertinent information and will coordinate with the PIC for authorization to transmit. (T-3) On EC-130J aircraft, the DSO will coordinate with the crew during mission planning regarding interphone connectivity. (T-3)

#### **16.5. Post Mission.** In addition to appropriate debriefs, the DSO will also ensure:

16.5.1. Equipment write-ups are passed on to maintenance. (T-3)

16.5.2. Post mission Technical Summary inputs are provided to the supporting analyst. (T-3)

16.5.3. Provide information to their units summarizing mission events, as required.

**16.6. Augmentation.** Some contingency operations may require operators from other units, or in some cases, non-aircrew personnel to provide tactical cryptologic support. In these cases, a mission-ready instructor-qualified DSO will fly as primary DSO, and be responsible for DSO inputs. (T-2)

## Chapter 17

### TACTICAL EMPLOYMENT PROCEDURES

**17.1. General.** This chapter describes the specific equipment requirements, training restrictions and regulatory guidance for employment procedures for the MC-130J. It is not a stand-alone reference and should be used in conjunction with AFTTP 3-3.E/MC-130J and other publications. In the case of any conflict between AFTTP 3-3.E/MC-130J (or equivalent), this manual takes precedence.

#### **17.2. Crew Duties.**

17.2.1. Pilot Flying (PF) maintains contour altitude and ensures terrain clearance. The PF is responsible for time control once time status is within 30 seconds of the Time Over Target (TOT)/Time of Arrival (TOA).

17.2.2. Pilot Monitoring is responsible for backing up the PF. The PM runs all checklists once airborne unless delegated to another crew member. The PM should be primary for all ATC communications, to include landing zone personnel, and provides non-secure communications IAW the Command Electronic Order of Information (CEOI). The PM monitors aircraft instruments and cross-checks aircraft altitude and terrain clearance using NVGs, radar scope interpretation, and the radar altimeter. The PM also assists the CSO with maintaining proper flight path, acquiring controlling terrain and identifying the objective area.

17.2.3. CSO directs the crew along the planned route, providing terrain and climb/descent advisories to the pilots, briefing turn points and time advisories, and time control when time status is greater than 30 seconds early/late. They are responsible for maintaining the desired flight path via radar scope interpretation and all other situational awareness tools. If use of the radar is denied, the CSO will use EO/IR, NVGs, and other sensors to assist in terrain clearance. The CSO programs and monitors the defensive systems and is primary for radio communication with C2, tactical control agencies (e.g., range and drop zone personnel), and other ground parties during mission events.

17.2.4. Loadmaster. Responsible for rear quadrant visual threat detection. Ensures that cargo compartment lights are off from ingress to egress in hostile areas at night. When in a threat environment, the ALE-47 portable flare fire buttons will be held. (T-3)

17.2.5. The following duties are divided between all crew positions: CNI-MU programming and updating, time control, mission planning, navigation, monitoring of fuel status (fuel should be checked at least once every 60 minutes), secure communications IAW the CEOI, and communications with C2. The PIC will ensure all navigation/communication duties are clearly understood prior to flight. This includes assigning responses for particular equipment in the tactical checklists. Emphasis will be placed on all dual use controls (CNI-MU, Radar, Fuel panel, Refuel Control panel, etc.). (T-3)

**17.3. Survival and Protective Equipment.** All personnel will wear the survival and protective gear as directed by the mission commander, local directives, or SPINs. (T-3)

**17.4. Equipment Requirements.** The minimum equipment required for various mission events are listed in [Table 17.1](#). Aircrew experience level and the mission scenario may dictate additional equipment requirements than those listed.

**Table 17.1. Tactical Operations.**

Event	Navigation Solution	APN-241	Radar Altimeter	EO/IR
Day LL <sup>1</sup>	1 x INU		1	
NVG/IMC LL <sup>1</sup>	1 x INU	X <sup>2, 3, 9</sup>	1	
Night VMC LL (non-NVG)	1 x INU	X <sup>2, 4</sup>	1	X <sup>4</sup>
Coastal/Threat Penetration			1	X <sup>5</sup>
NVG SCA	1 x INU		1	
IMC SCA	EGI FOM 2 or better -or- 1 x INU	X <sup>2, 6</sup>	1	
AMP-4 Landing		X <sup>2, 4</sup>		X <sup>4</sup>
Airdrop Operations	1 x EGI <sup>7</sup> -or- 1 x INU <sup>8</sup>			

**Notes:**

1. If aircraft do not possess the minimum equipment listed, they are restricted to flying MSA or to the wing position in a formation.
2. Either Map or MGM mode must be operational.
3. If APN-241 is inoperable, crews may fly NVG LL (VMC) over flat and rolling (non-mountainous) terrain.
4. Either the APN-241 or the EO/IR is required.
5. EO/IR must be operable for threat penetration over land.
6. Operable APN-241 not required with EGI Figure of Merit (FOM) of 2 or better.
7. Minimum of 1 x EGI navigation solution required for mission computer-directed airdrops (FOM greater than 4 requires an update).
8. Visual airdrops require 1 x operable INU.
9. Squadron Commanders may authorize crews to conduct mountainous NVG LL without the APN-241 on a case-by-case basis, provided EO/IR is operable.

**17.5. Mission Planning.** All pilots and CSOs will conduct a route study prior to any low-level operations. (T-3) The route study will emphasize NVG limitations and performance factors and their impact on terrain and obstacle clearance. (T-3)

17.5.1. A daylight route survey will be conducted for all unpublished training routes prior to night/IMC operations below 500 feet AGL. (T-3) Any route or route segment not surveyed or routinely flown within the last 12 months will be considered un-surveyed. (T-3)

17.5.2. En route Planning. Crews should fly tactical missions at the highest altitude commensurate with the threat environment(s). During training, FLIP, ICAO procedures or training considerations may dictate greater weather or altitude minimums.

17.5.3. All missions flying low-level should initially takeoff with main tanks full to reduce the effects of wing upbending and increase the center wing-box service life. Decreased takeoff fuel in the main tanks can decrease the center wing-box service life as much as 47%.

17.5.4. Mountainous terrain is defined as a 500 foot or greater terrain differential in 1/2 NM or less.

17.5.5. Chart requirements. Planned routes will be drawn on a 1:500,000 Tactical Pilotage Chart (TPC) or larger scale chart. (T-3) Use a 1:250,000 Joint Operational Graphic (JOG) or larger scale chart for overland threat penetration operations, mountainous NVG low-level operations, and the objective area, unless not available or of an inferior quality to a TPC. If a TPC is used for planning, adjust MSA altitudes to account for the larger contour interval unless terrain elevation can be positively verified by other means. Every effort must be made to minimize chart clutter. If electronic charts are used, a backup paper chart, prepared IAW chart requirements, must be immediately available for each crew member using electronic charts. (T-3) **WARNING:** Aeronautical charts do not depict man-made obstacles less than 200 feet AGL or a change in terrain until it exceeds the chart contour interval. The worst situation would occur if a 199-foot tower sat on terrain with an elevation just below the next higher contour. For a 1:500,000 (TPC) with a contour interval of 500 feet, this results in an uncharted obstacle existing 698 feet above charted terrain. Additionally, the highest spot elevation on any given leg may not be the highest terrain as in the case of gradually rising elevations. **Note:** If a NVG route (any terrain condition) has been planned using a JOG and elevations and altitudes are verified, the route may be flown with reference to a TPC.



Figure 17.1. Inherent Chart Error.

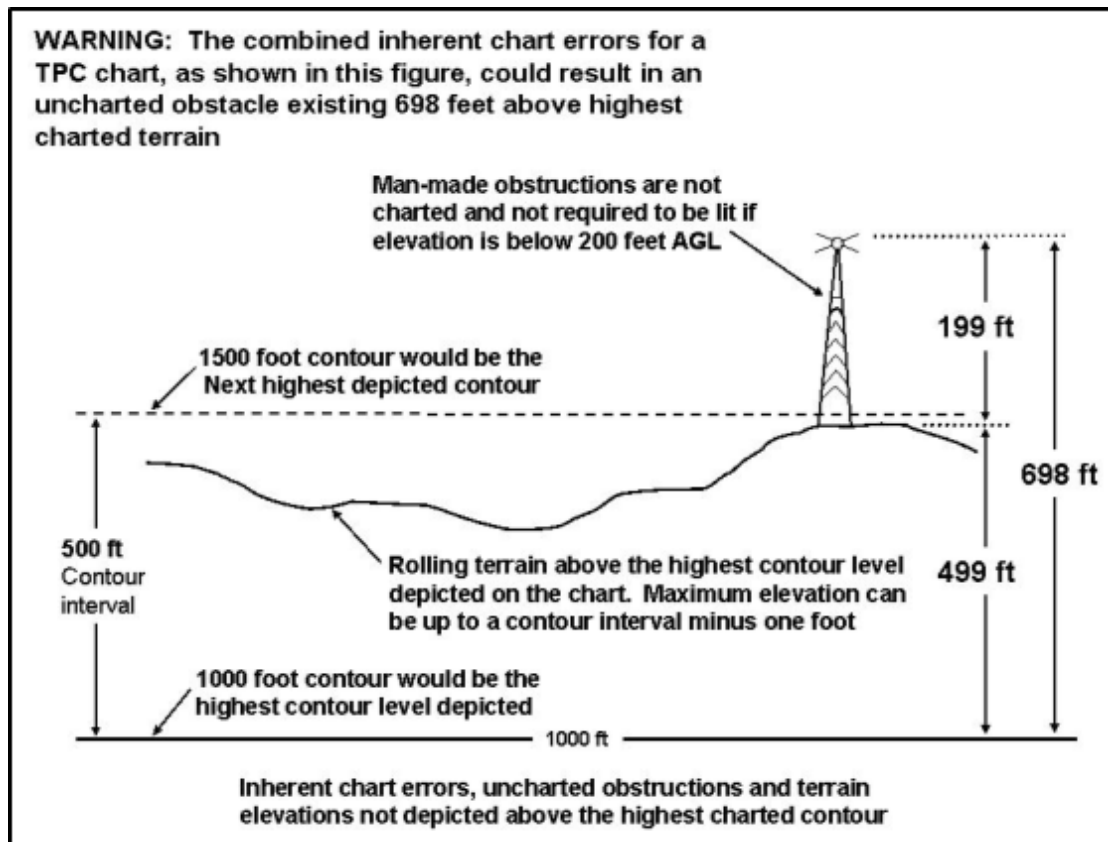

17.5.5.1. Color copies and laminated charts are acceptable provided the contour and contrast remain intact and the chart is used for preflight route study and the flight. If laminated charts are used, the crew will ensure that the laminate does not degrade the quality or readability of the chart and that all data remains intact. (T-3)

17.5.5.1.1. Minimize chart clutter. NVG altitudes and planned NVG route of flight will be annotated on charts when NVG low-level is planned. (T-3) Start climb points and the controlling terrain location will be annotated on charts if required due to mission factors such as terrain elevation changes, hidden terrain, reduced visibility or low lunar illumination. (T-3)

17.5.5.1.2. NVG Altitudes. NVG altitudes are an altitude designed to provide a degree of terrain masking and clearance along the planned flight path. Base NVG altitudes on terrain elevation 0.5 NM either side of flight planned route, adding the planned en route AGL altitude.

17.5.5.1.3. Start climb points are determined to identify where along the planned route of flight a climb must be initiated to maintain a specific NVG altitude profile in mountainous terrain. These points are determined by working backwards from the NVG altitude along the planned route of flight using a preplanned climb gradient.

17.5.5.2. The chart series, scale, and edition will be annotated on the chart. (T-3) The current Chart Updating Manual (CHUM) review date will also be annotated on the chart. (T-3)

17.5.5.3. Place the Emergency Safe Altitude (ESA) in bold numbers on the chart. When multiple ESAs are used, or when strip charts are used, the ESA will be annotated on each chart segment. (T-3) Place a double box around the obstacle or terrain that defines each ESA.

17.5.5.4. Charts will include course centerline, turn points, turn point labels, magnetic course, MSA, and MSA controlling terrain for each leg of the flight plan. (T-3)

17.5.5.5. Operational Advisory Arrows are optional on pilot charts.

17.5.5.6. When transitioning from one chart to another, allow a sufficient route overlap.

17.5.5.7. The pilot and copilot may share a single low-level chart during flight. If this option is used, both the pilot and copilot must participate in pre-mission route analysis using the single chart.

17.5.5.8. Order of Battle. In an exercise or actual combat situation, it is required to depict threat information directly on the navigational route chart. (T-3) Inclusion of threat capabilities may classify the chart. **Note:** Classify charts depending on information sources and methods used to obtain this data (required only if classification is Confidential or higher).

## 17.6. Preparation for NVG Operations.

17.6.1. General. Aircraft are normally configured for NVG operations prior to departure. In addition to the normal aircraft preflight, crew members have specific tasks to prepare the aircraft for NVG landing missions. Additional equipment is necessary to prepare the aircraft and crew members for missions that require NVG operations. The recommended aircraft equipment requirements and aircrew responsibilities are listed in this section.

### 17.6.2. Aircraft Equipment Kit.

17.6.2.1. Aircraft blackout and eyebrow curtains.

17.6.2.2. Porthole covers for the cargo compartment.

17.6.2.3. Chemlights for use in marking emergency exit handles.

### 17.6.3. Aircrew Equipment Kit.

17.6.3.1. NVGs. Mission requirements and duration of the deployment will be determining factors for the total number of NVG sets required. The PIC must ensure there is one spare set of preflighted NVGs for the flight deck crew members. (T-3) When the mission requires the loadmasters to use NVGs, a spare set will be available for their use as well. (T-3) All crew members will perform a thorough preflight of their NVGs. (T-3)

17.6.3.2. Helmets with mounts for NVGs.

17.6.3.3. IR filtered flashlights, finger lights, lip lights or chem lights, if required.

17.6.4. Ensure both interior and exterior lights are correctly set and are as dim as possible commensurate with safety and visibility. (T-3)

## 17.7. Low-Level Operations.

17.7.1. AFTTP 3-3.E/MC-130J augments procedures in this manual. **WARNING:** The CSO or PM must continually keep the PF apprised of flight progress and anticipated terrain

elevations, obstructions, climb points, and descent points. (T-3) Any tower or man-made obstruction within 3 NM of planned flight path must be positively identified visually or electronically. If not identified, remain clear laterally by 1 NM or vertically by planned en route AGL altitude.

17.7.2. Emergency Safe Altitude (ESA). ESA is an altitude that will provide positive terrain clearance during situations that require the exiting of the low-level environment. To compute ESA, add 1,000 feet (2,000 feet in mountainous terrain) to the highest obstacle or terrain feature within 10 NM of route centerline or intended flight path (whichever is greater), rounded to the next 100 foot increment. Use of area ESAs is recommended whenever possible; however, a single ESA is sufficient when there are no significant changes in topography. ESA will be annotated on all flight charts. (T-3)

17.7.3. Minimum Safe Altitude (MSA). MSA provides terrain clearance and limited threat avoidance during situations that require the interruption of low-level operations.

17.7.4. To compute MSA for each leg or leg segment, add 500 feet or 400 feet plus one contour interval to the elevation of the highest terrain or obstacle within 3 NM of route centerline or the planned flight path (whichever is greater), and round up to the next 100-foot increment.

**Figure 17.2. Minimum Safe Altitude.**

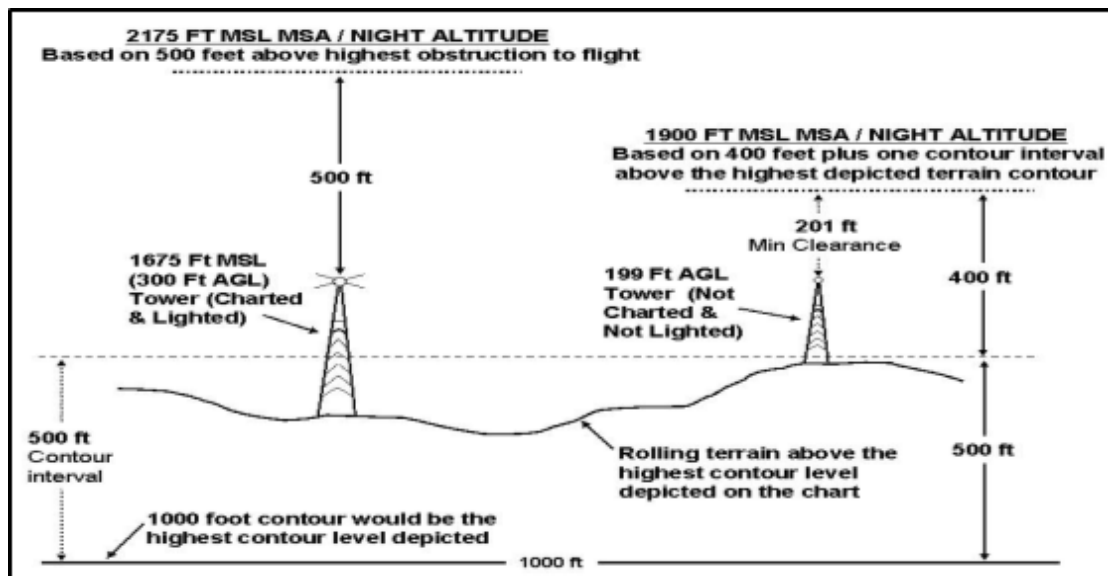

17.7.5. MSA for HAAR/TAAR. To compute MSA for each refueling track, add at least 1,000 feet of clearance above all obstacles within 5 NM of course to be flown and round up to the next 100-foot increment.

17.7.6. Low-Level Weather Requirements. In accordance with AFI11-202, Vol 3. During training operations, FLIP, ICAO procedures, or training considerations may dictate higher weather minimums. Higher minimum visibility may be required to identify and clear obstacles. **Note:** Lack of sufficient illumination may prevent NVG contour operations in otherwise VMC conditions.

17.7.7. Missions planned when the lunar illumination is forecast to be less than 0.8 millilux or 10% effective illumination during the mission require an additional level of RM. The squadron CC/DO will be made aware of the RM assessment and risk mitigation conducted for missions planned to be flown in low illumination conditions. (T-3)

17.7.8. Low-Level Altitudes.

17.7.8.1. Day VMC Low-Level Altitude. 300 foot AGL contour.

17.7.8.2. NVG Low-Level Altitudes. The minimum en route altitude is 300 feet AGL. Squadron commanders may restrict crews to 500 feet AGL in mountainous terrain. The minimum in-flight visibility is 3 SM. A higher minimum visibility may be required to identify and clear obstacles. **Exception:** During terminal area operations (airdrops and approaches), do not descend from en route altitude until the objective is identified and adequate terrain clearance is assured. Higher altitudes should be flown if terrain-masked.

17.7.8.3. Night VMC (Non-NVG). Minimum altitude is MSA. When the altitude for the next leg or segment is higher than the altitude currently being flown, complete the climb prior to the turn point or segment. When the altitude for the next leg or segment is lower than the current altitude, do not initiate descent until established on the new leg or segment. **Exception:** During terminal area operations (airdrops and approaches), do not descend from en route altitude until the objective is identified and adequate terrain clearance is assured. Conduct night VMC (non-NVG) HAAR/TAAR operations with a refueling altitude at MSA or higher.

17.7.8.4. Crews may fly low-level in IMC at MSA altitudes. During training, conduct planned IMC routes under instrument flight rules (IFR) on a published or surveyed route unless FLIP or host nation rules define other procedures.

17.7.8.5. Threat Penetration (TP). Must be pre-planned and is restricted to flat/rolling (non-mountainous) terrain and coastal penetrations. (T-2) Limit the time at TP altitude to the duration needed to avoid/negate the threat. Minimum TP altitude is 100 feet AGL.

17.7.9. Climb to MSA when either pilot must leave the seat or loses NVGs during low-level flight. **Exception:** If performing a planned seat swap for training with an Instructor Pilot in the seat, climb to a safe altitude.

17.7.10. Altimeter Settings. Use the best available altimeter setting. It is vital that aircrews accurately update all altimeters prior to low-level/objective area operations. When a current local altimeter setting is not available, or a reliable altimeter update (ALT UPDATE/TRUE ALT) cannot be accomplished, use the lowest forecast altimeter setting.

17.7.10.1. An ALT UPDATE altimeter setting derived in-flight should only be used when an ATC-provided altimeter setting is unavailable. An ALT UPDATE should be performed prior to all airdrops or landings. Obtain an ALT UPDATE as close to the objective area and as near the objective altitude as possible. Use sound judgment when updating aircraft altimeters and cross-check elevations and new settings with all available information.

17.7.10.1.1. If TRUE ALT functionality is available, aircraft should use the TRUE ALT as a primary means of altimeter update

17.7.10.1.2. IF TRUE ALT functionality is unavailable, and a valid GPS position is available (FOM 2 or better), the PM should update the aircraft altimeter setting to equal

the GPS altitude once established on drop altitude. For tactical approaches, set altimeters to the reported Surface Altimeter (QNH) setting, if available. If surface QNH is not available, conduct an altimeter update if ingress altitude is within 1,000 feet of field elevation; otherwise, set the forecasted lowest altimeter setting.

17.7.10.1.3. If TRUE ALT functionality is unavailable, and a valid GPS altitude is unavailable (FOM 3 or greater), the CSO should update the pressure altimeter by recording the current altimeter setting, AGL altitude from the radar altimeter, and the MSL altitude from the pressure altimeter over a known elevation and computing a new setting or use the minimum altimeter setting for the objective area. This works well when flying over a body of water, or flat terrain. Ensure the radar altimeter is fully operational and use sound judgment when updating aircraft altimeters. (T-3) **WARNING:** Obtaining an ALT UPDATE at a significantly higher or lower altitude than the target can induce substantial altimeter error. Use extreme caution when updating the pressure altimeter to a higher setting, as lower absolute altitudes will result.

17.7.10.1.4. Apply cold weather altimeter corrections IAW AFI 11-202, Vol 3, MAJCOM Supplement to all non-GPS derived barometric altitudes.

## 17.8. Low-Level Emergency Procedures.

17.8.1. Crew Disorientation. Threat permitting, start a climb to ESA when a crew becomes disoriented on a low-level mission. Continue the climb until ESA is reached or a positive fix is obtained. After obtaining a positive fix, descend and resume low-level operations. The CSO/PM will cross-check timing and adjust as necessary. (T-3)

17.8.2. Spatial Disorientation. The PM will be ready to immediately take control of the aircraft if the flying pilot experiences spatial disorientation or a NVG malfunction. (T-3) In either event, start a climb to at least MSA until the pilot experiencing the problem is ready to assume PM duties.

17.8.3. Inoperative NVGs. During an NVG takeoff or landing, the PM must react quickly to assume control and execute the appropriate action, regardless of qualification or pilot position. The crew must be ready to turn on overt landing and taxi lights to assist in the maneuver.

17.8.4. Aircraft System Failure. Begin a climb to MSA when a known or suspected malfunction prevents continued safe low-level operations.

17.8.5. Emergency Climb. Consider this procedure in cases of (but not limited to): certain equipment malfunctions, spatial disorientation, inadvertent weather penetration, critically low aircraft altitude and/or airspeed, and/or loss of situational awareness during low-level operations. Any crew member may initiate this procedure by stating “Emergency Climb.” If required/called for, execute the procedure as soon as possible. **Table 17.2** lists the steps for the Emergency Climb procedure.

**Table 17.2. Emergency Climb Procedure.**

1. Announce “Emergency Climb” to the crew over interphone.
2. Execute the 1C-130(M)J-1 Wind Shear Procedures.
3. Close ramp and door (if open).

4. If feasible, turn away (with consideration for stall margin) from terrain. If not possible, climb straight ahead for the maximum climb angle.
5. The PM will monitor and call airspeed as appropriate. Pilots must monitor stall caret.
6. The CSO will state an MSA or ESA as appropriate, monitor terrain (via radar, chart, etc.) and state “clear of terrain” when above all critical terrain.
7. When clear of all terrain, adjust pitch, power and airspeed for a normal climb out and level off.
<b>WARNING:</b> If impact with terrain is imminent, use 100% flaps, 10 knots above the stall caret and crash the aircraft straight ahead.

### 17.9. Radar Altimeter Usage.

17.9.1. Set radar altimeter no lower than 20% below the planned en route altitude. Depending on required altitude profile, illumination, and proficiency, a higher radar altimeter setting may be appropriate. Set radar altimeter no lower than 90 feet for threat penetration.

17.9.2. The PF will make an immediate correction any time the system provides an “altitude” annunciation, unless prebriefed for airdrop or specific altitude crossing heights. (T-2) **Note:** Regardless of the radar altimeter setting used, do not wait for an annunciation to begin a correction.

### 17.10. Defensive Maneuvers and Equipment.

17.10.1. Practice Combat Maneuvers. All crew members will be prebriefed and advised of the time period/portion of the flight when practice threat maneuvers will be executed. (T-3) Crew coordination is essential in avoiding injury to crew members during practice threat maneuvers.

17.10.2. Expendables/ECM Training. Conduct all expendables training IAW CJCSM 3212.02, *Performing Electronic Attack in the United States and Canada for Tests, Training, and Exercises*, AFI 11-214, AFI 10-706, *Electronic Warfare (EW) Operations*, AFI 13-212, *Range Planning and Operations*, and applicable local and host nation directives. Dispense only when approved by the controlling agency IAW agency procedures and restrictions. When over open water, do not drop expendables below 500 feet AGL or within 3 NM of any surface vessel, platform or landmass. Operational electronic attack software can only be used for training missions in CONUS after the signal collection risk has been evaluated (see CJCSM 3212.02 OPSEC considerations). **WARNING:** Practicing defensive threat maneuvering does not constitute authority to deviate from limitations in the flight manual or this manual.

17.10.3. Formation Threat Maneuvering. The optimal situation occurs when the on-board or off-board equipment gives advance warning and all that is required is a deviation around the threat. As the immediacy of the threat increases, more maneuvering may be required. Maneuvering abruptly or at high “G” loads or high bank angles should be done only when the threat is in sight and no other course of action is available. During training, emphasis on defensive maneuvering (both single-ship and in formation) should be on early identification

and avoidance of threats. Any threat breaks in formation must be thoroughly briefed prior to flight, executed smoothly and terminated immediately if flight safety is compromised. In training, if you lose sight of the preceding aircraft during a threat maneuver, make a radio call with your altitude and trend if climbing or descending, e.g., "RAID 81, 2's blind, climbing through 2,000 feet." All aircraft will bring up their lights and lead will direct altitude separation until the blind aircraft has the preceding aircraft in sight. (T-3)

17.10.4. Threat Penetration. Visual pilotage is the primary height reference. Pressure and radar altimeters are secondary height references. Limit the time spent at threat penetration altitude to the duration needed to avoid the specific threat. During peacetime, the following restrictions apply:

17.10.4.1. A certified mission pilot must be in the left seat or a mission IP/EP in either seat. (T-2)

17.10.4.2. **WARNING:** Bank angle is restricted below 200 feet AGL; therefore, descending turns must be avoided. (T-2)

**17.11. Degraded Systems Training (DST).** DST is used to prepare crews to accomplish the mission simulating certain pieces of equipment inoperative (or intentionally turned off for emission control). On nonlocal routes, designate leg segments during the route brief. The following restrictions and procedures are designed to maximize training and safety: (T-3)

17.11.1. Visibility must be 5 SM in mountainous terrain.

17.11.2. One radar altimeter must be operational and on.

17.11.3. The APN-241 radar must be operational.

17.11.4. Mission instructor or evaluator must be in either the pilot or CSO position.

17.11.5. An Instructor (P/CSO) must display/monitor the APN-241 during DST of the radar.

17.11.6. PICs will brief the following items:

17.11.6.1. Equipment simulated inoperative.

17.11.6.2. Aircrew coordination.

17.11.6.3. Disorientation and emergency procedures.

**17.12. Self-Contained Approach (SCA).**

17.12.1. SCA procedures may be used for approaches to all landing surfaces, and for either overt or covert airland operations. Comply with local ATC restrictions and host nation agreements, as appropriate.

17.12.2. En Route Altitude. The altitude profile may consist of MSL altitudes, NVG altitudes, or any combination. In all cases, an MSL altitude profile will be planned. (T-3)

17.12.3. Weather minimums.

17.12.3.1. SCAs must be conducted in VMC unless IMC operations are approved IAW 11-202 Vol 3. If approved, IMC SCA weather minimums will be no lower than 200 feet and 1/2 SM.

17.12.3.2. For National Geospatial-Intelligence Agency (NGA)-published SCAs, use published minimums.

17.12.4. Minimum Descent Altitude (MDA). To compute MDA for VMC operations, add a minimum of 100 feet to the Touchdown Zone Elevation (TDZE). For approved IMC SCA operations, add a minimum of 200 feet to the TDZE.

17.12.5. Missed Approach Point (MAP). The MAP will be placed no further than zero distance to go on the mission computer or as required for obstacle clearance on the SCA plate at MDA. (T-3)

17.12.6. A full SCA plate for landing runway is required. Construct an approach plate for the landing runway using the AF Form 4118, Approach Planning Tool software, or a Group Standardization and Evaluation (OGV) approved planning form.

17.12.7. Approach Path and Glideslope Construction. Plan IMC SCAs with a 3° glideslope from en route altitude unless terrain or obstructions dictate a different glideslope. Avoid using glideslopes greater than 5°. Plan initial VMC SCA glideslopes commensurate with terrain, obstructions, threat and aircraft limitations. Plan to intercept a 3° glideslope at or before the MDA.

17.12.8. Chart Preparation. Use the largest scale chart available from 10 NM inbound. A 1:50,000 chart is preferred, but in no case will it be larger than 1:250,000. Select position and altimeter update points and brief the position to the crew during route study. Chart construction will be IAW this chapter and include the following additional items: The Initial Point (IP), slowdown points, descent point, and the missed approach, departure, and go-around paths. Ensure update points for the mission computer and altimeter are annotated. It is of utmost importance to have sufficient, reliable position and altitude update points prior to the IP and final run-in. (T-3)

### 17.13. SCA Template Construction.

17.13.1. Use the most current sources for topographic point obstruction, and airfield information. Consider using radar reflectors, radar beacons, or existing airfield NAVAIDS to increase the reliability of the approach.

17.13.2. En route Altitude. In all cases, an MSL altitude profile will be planned. (T-3)

17.13.3.1. Straight-in SCAs. Draw the horizontal obstacle clearance template, depicted in, on **Figure 17.3** a 1:250,000 or larger scale chart, if available. The template begins 0.3 NM either side of LZ centerline at the touchdown point, extending outward to 1 NM either side of centerline at decent point or 3 NM, whichever is greater, from the touchdown point and then extended 1 NM beyond the planned descent point (For example, a 3.2 NM planned descent point requires a 4.2 NM long template). If the planned descent point is less than 2 NM from the touchdown zone, then the standard 3 NM template will not require extension. (T-2) **Note:** These are minimum distances and may be increased. Consider such factors as the availability of radar or EO/IR targets, recent NAVAID performance and time of last system position/altitude update.



Figure 17.3. SCA Horizontal Obstruction Clearance Template.

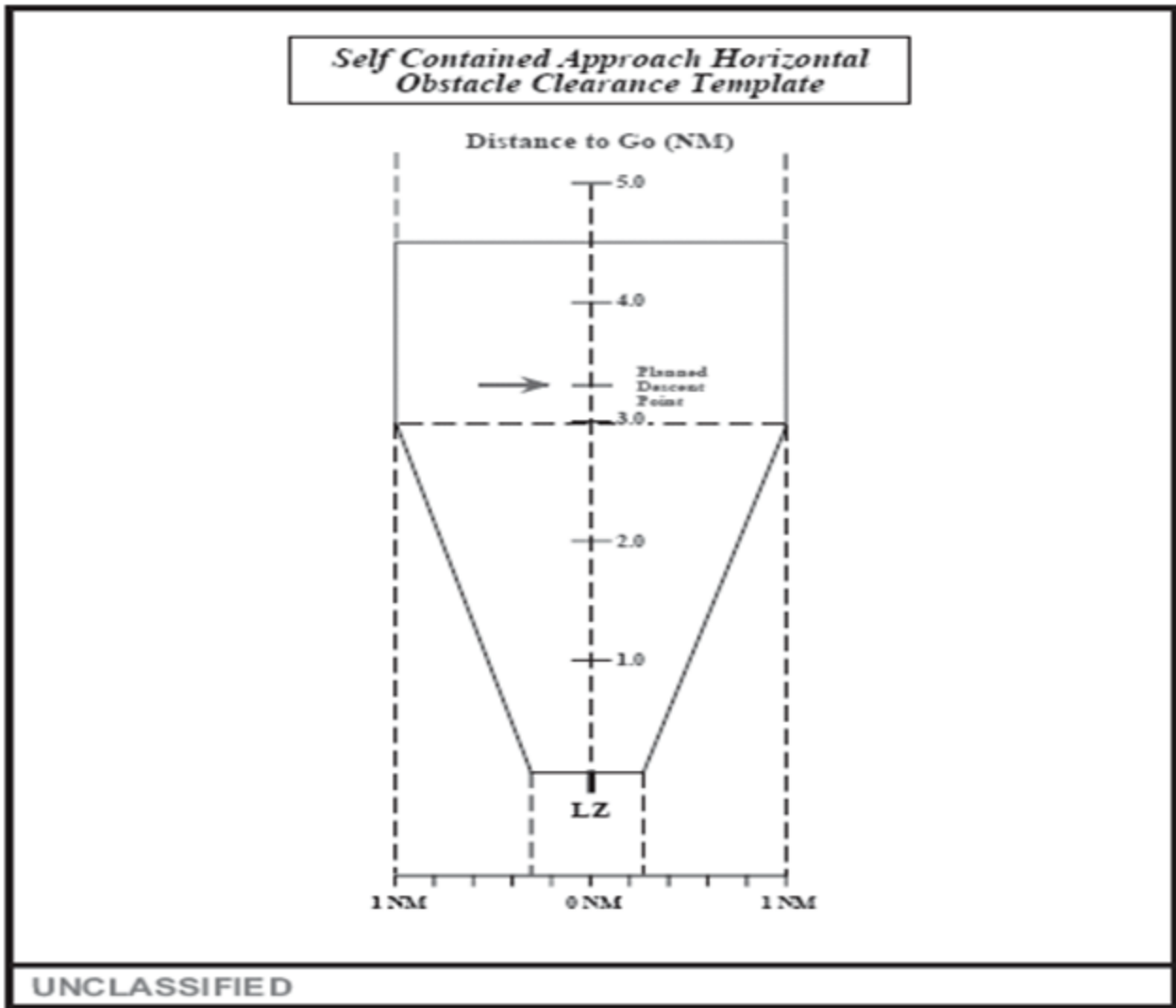

UNCLASSIFIED

Figure 17.4. Turning SCA Horizontal Obs Clearance Template (Not to Scale) (1 of 2).

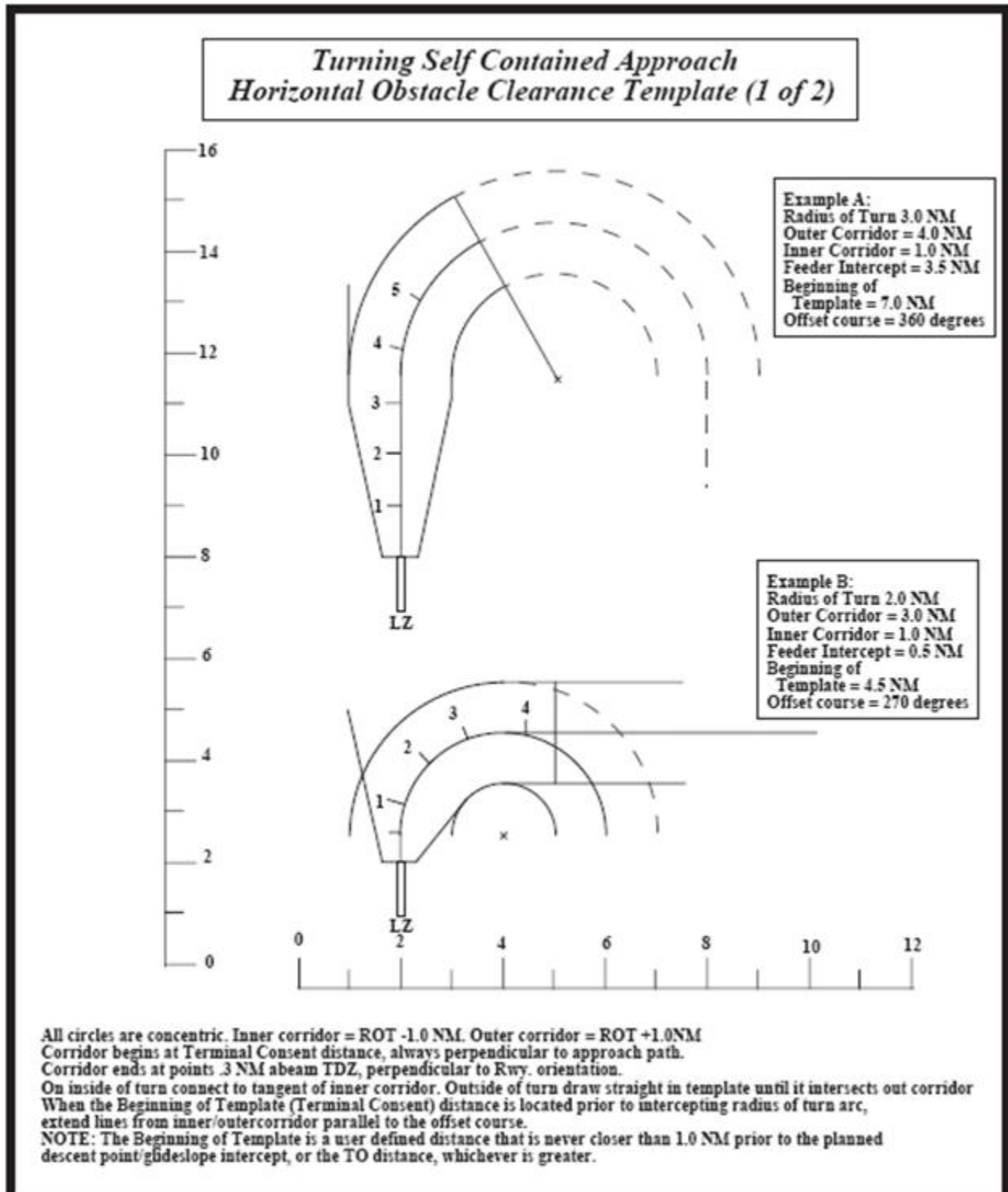
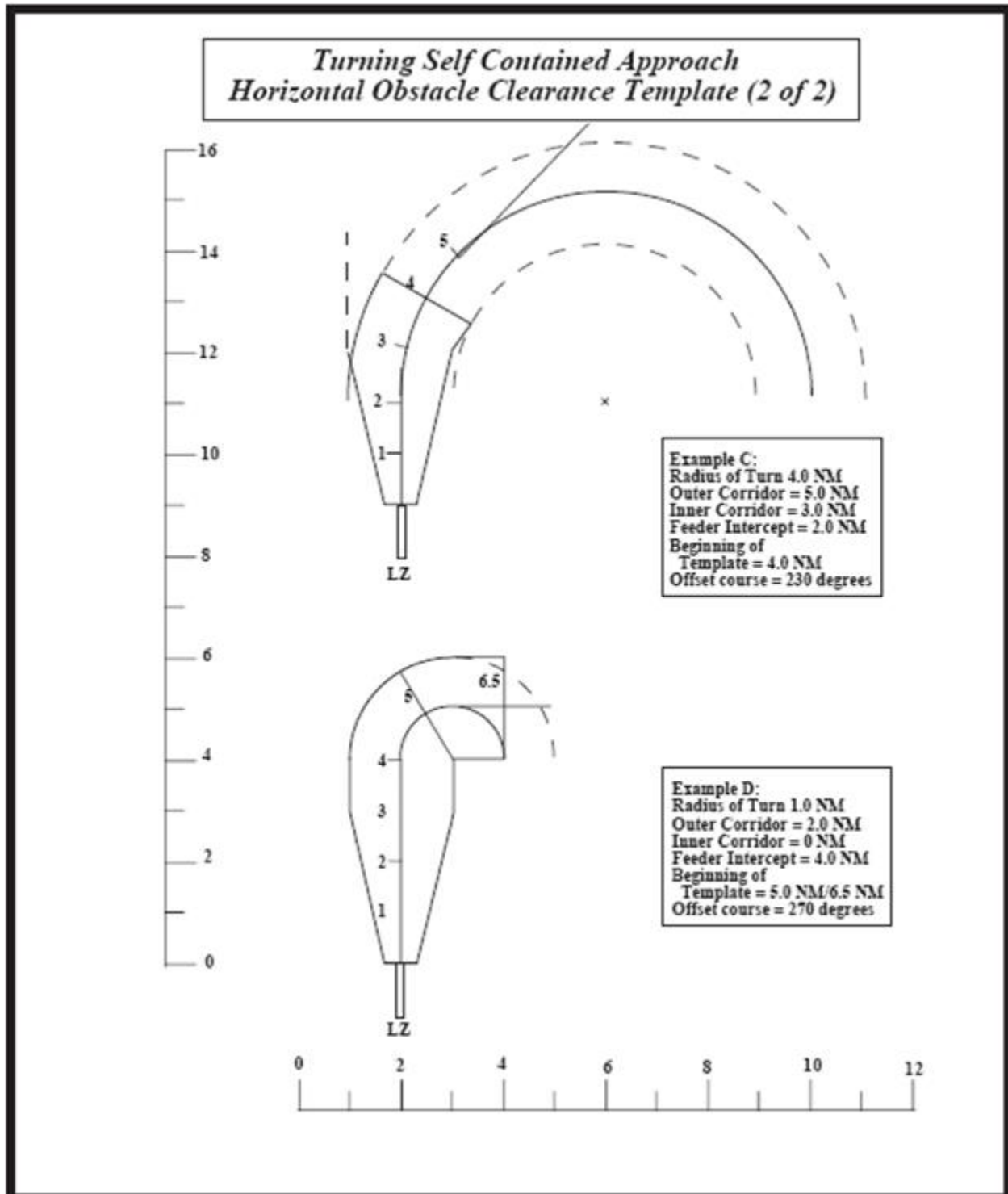

Figure 17.5. Turning SCA Horizontal Obs Clearance Template (Not to Scale) (2 of 2).



17.13.3.2. Turning and Circling SCAs. The obstacle template for a turning or circling SCA consists of a modified version of the straight-in template. Draw the turning SCA horizontal obstacle clearance template, depicted in [Figure 17.5](#), on a 1:250,000 or larger scale chart if available. Draw the straight-in portion of the SCA template as if planning a

straight-in SCA. Select the feeder distance where the aircraft will intercept runway centerline. From the pre-planned radius intercepting the feeder distance draw an inner and outer corridor. For the outer corridor, draw a concentric circle with radius 1.0 NM greater than the planned radius of turn. For the inner corridor, draw a concentric circle with a radius 1.0 NM less than the planned radius of turn. Connect the inner and outer corridors with a line that is perpendicular to the approach path at the point 1 NM prior to glideslope intercept. When the glideslope intercept occurs prior to intercepting the turning path, draw lines parallel to the offset course tangent to the outer and inner corridors. When using a large radius with a short feeder distance, draw a tangent line from the inner corridor to the template 0.3 NM abeam the runway. See [Figure 17.4](#) example B.

17.13.4. Obstacle Clearance. The location of terrain and obstructions will dictate the glideslope and altitude profile used. Use the following procedures to analyze obstacles: (T-3)

17.13.4.1. SCA Vertical Template Construction. Starting at the touchdown zone, construct a glideslope using the desired gradient (feet/ NM) to a point along the final approach course (or transition path, if applicable) where it intercepts the planned approach altitude (refer to [Figure 17.7](#)). Annotate the glideslope MSL and AGL altitudes for each 0.5 NM distance-to-go increment out to the planned descent point.

17.13.4.2. Significant and Critical Obstacles. Using current large-scale charts, airfield diagrams, airfield sketches, approach plates, and imagery, locate significant obstacles within the boundary of the horizontal template. Significant obstacles are those within 300 feet of the desired glideslope. Determine the HAT for each obstacle by subtracting TDZE from the MSL elevation of the obstacle. For each obstacle, plot the along-course distance from touchdown and HAT on the critical obstacle graph as shown in [Figure 17.6](#), Critical Obstacle Chart. An obstacle is considered critical if it falls above the reference line for the planned glideslope or its extension along the depicted baseline.

17.13.4.3. Draw the relative position of each critical obstacle on the template and annotate its distance-to-go, distance abeam final course centerline and height (AGL and MSL).

17.13.4.4. For each critical obstacle identified, preplan and brief a specific means of avoidance to be used during the approach. The following examples may be used separately or in combination:

17.13.4.4.1. Use a steeper glideslope. Glideslopes exceeding 4 degrees should be carefully considered due to the high rate of descent required.

17.13.4.4.2. Move the touchdown point further down the runway.

17.13.4.4.3. Increase MDA.

17.13.4.4.4. Establish an intermediate step-down altitude above the MDA at which the aircraft will level off until positive separation from the obstacle is assured. (T-2)

Figure 17.6. Critical Obstacle Chart.

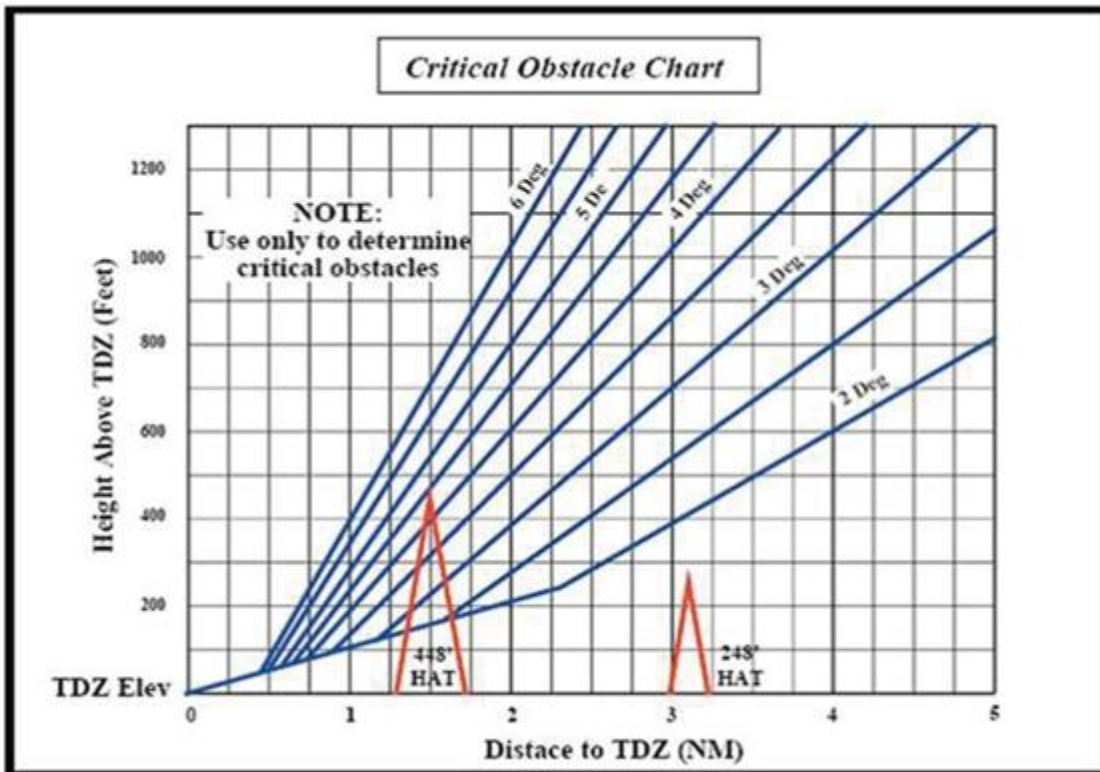
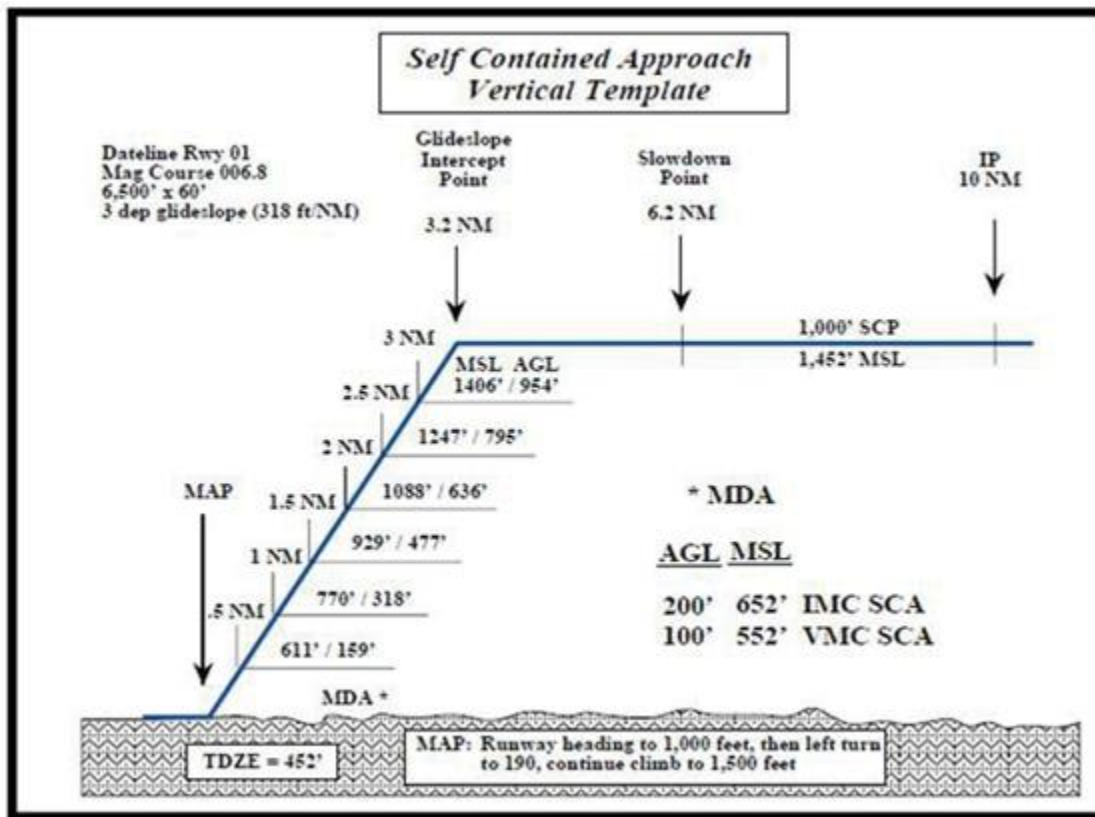

Figure 17.7. SCA Vertical Template.



17.13.5. Missed Approach and Departure. For planning, allow a minimum of 0.3 NM along track error and 0.3 NM cross-track error at the MAP. Assume IMC when choosing the missed approach/departure flight path. Construct a horizontal obstacle clearance template beginning at the MAP and incorporating the planned missed approach/departure flight path. Use TDZE as the MSL start point for the missed approach. If the terrain along this flight path (including the above errors) rises at a rate greater than 200 feet/NM, refer to the Performance Manual to verify that three-engine climb out will clear terrain. (T-2) Use the three-engine climb angle in place of glideslope.

17.13.5.1. The horizontal obstacle clearance template for climb out extends from the approach end of the runway out to 1.0 NM past level off at the initial escape en route altitude. The lateral limits of the climb out template are the same as for the straight-in approach.

17.13.5.2. If any critical obstacles are identified, consider using turns during climb out to avoid them. Ensure that the three-engine climb path provides sufficient clearance from obstacles and terrain along the flight path.

#### 17.14. SCA Execution.

17.14.1. The Infil/Exfil checklist is mandatory for all SCAs, with both pilots monitoring system/CSO guidance. When the mission, local ATC restrictions and host nation agreements allow use of covert lights, mark the runway as depicted in AFI 13-217, if required.

17.14.1.1. General. Depending on the type of landing, the Pilot will set lighting as required. (T-3) If the PF requires lights to acquire the LZ, he may call for additional lights as required. Each pilot will ensure NVG batteries are operational during the Infil/Exfil checklist. (T-3)

17.14.1.2. Instrument Approaches using the Infil/Exfil Checklist. When the tactical situation dictates flying an instrument approach while utilizing the Infil/Exfil checklist, ensure all briefing items from the approach checklist are covered. (T-3)

17.14.2. Aircraft lighting will be as briefed/directed by ground parties if required for authentication purposes. (T-3) The use of covert lighting will be thoroughly briefed in respect to threat, runway environment and authentication procedures. (T-3)

### **17.15. SCA Crew Actions.**

17.15.1. Required warnings and calls.

17.15.1.1. Distance call at “2 NM” (from the landing zone); “begin descent”; “missed approach point” (if other than approach end of runway); and “100 feet,” “50 feet,” “25 feet,” and “10 feet” above touchdown. Additionally, the CSO will update the pilots on course, distance-to-go, and glide path profile every 1/2 NM, beginning at glideslope intercept, until the “minimums” call. (T-3)

17.15.1.2. The CSO will call additional time advisories as required by the user and Infil/Exfil Checklist. (T-3)

17.15.2. The PM will back up the flying pilot on the displays and confirm terrain clearance using all available means. (T-3)

17.15.3. At the Initial Point:

17.15.3.1. The CSO will verify final course guidance accuracy. (T-3)

17.15.3.2. The CSO will confirm LZ alignment and give final headings as required. (T-3)

17.15.3.3. Maintain en route profile until descent for landing.

17.15.4. Slowdown Procedures.

17.15.4.1. Slowdown points will be planned and briefed for tactical approaches. (T-3) The slowdown is normally initiated by a call from the CSO. Pilots should initiate their own slowdowns for overhead and downwind approaches.

17.15.4.2. Maintain a minimum of threshold speed for the given flap configuration (approach speed for turning). Once the gear is down and locked, track flaps to 100% (if required), and slow no lower than max effort threshold speed (approach speeds for turns).

17.15.5. Glideslope Intercept.

17.15.5.1. The PF will begin descent upon CSO direction or following the flight director cue unless directed otherwise by the CSO. (T-3)

17.15.5.2. At glideslope intercept, the CSO will state “Begin Descent” and should repeat the desired initial descent angle. The CSO will monitor course and glideslope deviations. (T-3) Report deviations greater than 50 feet vertically, or 50 yards horizontally, along with an advisory as to whether the aircraft is correcting to, paralleling, or diverging from

course/glidepath. **WARNING:** The obstacle clearance procedures in this chapter are not applicable to NVG operations conducted in a visual pattern. The pilot must maintain visual contact with the LZ and with surrounding terrain in order to execute a successful approach. (T-2) **WARNING:** The PM and CSO must closely monitor radar altimeters to ensure accuracy of altimeter settings to prevent inadvertently flying below planned AGL minimums. (T-2)

17.15.6. Setting Radar Altimeters. Radar altimeters should be set no lower than 50 feet below decision height or height above touchdown once slowdown has commenced.

17.15.7. Set the MDA in the Ref Set panel. **WARNING:** Use of a 5° glideslope can cause descent rates in excess of 1,000 feet per minute.

17.15.8. Descent. Do not descend below MDA until the LZ environment is identified visually and confirmed by both pilots. Whoever identifies the LZ first will call out "ZONE IN SIGHT," its clock position, and any discrepancies noted (i.e., any lights out, etc.). Both pilots will then confirm the zone and cross-check the alignment for the proper heading. (T-2)

17.15.9. The CSO will use the APN-241 Low Power Color radar (LPCR) and/or EO/IR (if available) after completing the final position update to verify the runway has been correctly identified and is clear of obstructions. (T-3)

17.15.10. After Touchdown. **Note:** During the initial Infil/Exfil brief, the pilot may prebrief the opening of the ramp and door upon reversing of the engines.

17.15.10.1. The copilot and CSO will assist the pilot in locating the offload/onload point once taxi speed is reached and clear for other aircraft and obstructions. (T-3)

17.15.10.2. Use overt/covert taxi and landing lights to the minimum extent required to maintain visual references.

17.15.11. Takeoff.

17.15.11.1. Accomplish the ON THE RUNWAY portion of the INFIL/EXFIL checklist.

17.15.11.2. The CSO will provide a departure heading, altitude and terrain considerations. (T-3)

17.15.11.3. The PF will make the takeoff wearing NVGs. (T-3) The PM will wear NVGs and be prepared to fly the planned departure on NVGs or transition to instruments and fly the CSO's directions in the event of NVG failure. (T-3)

17.15.11.4. Use IR taxi and landing lights to the minimum extent required to maintain visual references during takeoff roll. Interior lighting is the same as for the approach and landing. The PF and PM will clear the LZ for obstacles. (T-3)

17.15.11.5. Use normal takeoff performance unless max effort performance is required. At refusal speed, the copilot calls "Go." At takeoff speed, the copilot calls "Rotate." If takeoff and refusal speed are equal, the copilot will only state "Rotate." (T-3)

17.15.11.6. At takeoff speed, the PF will rotate the aircraft to establish a positive climb rate. (T-3) The PM checks the pitch attitude and will raise the landing gear on the command of the PF after ensuring a positive rate of climb. The PM may take control of the aircraft if directed by the PF and continue the climb out to the egress route altitude.



17.15.11.7. The CSO will advise the pilots of the initial on course heading and call altitudes climbing from 50 through level off as required for terrain clearance. (T-3)

17.15.11.8. As soon as conditions permit, the loadmaster will check equipment restraint and condition/needs of the onboard user. (T-3)

17.15.12. Go-Around and Departure Procedures. **CAUTION:** Pilots are more susceptible to spatial disorientation during NVG go-arounds and departures.

17.15.12.1. When executing a go-around or departure, the CSO will state the initial heading and “Climb to XXX feet” or MSA and will call climbing altitudes as required for terrain clearance from 50 feet to level off. (T-3)

17.15.12.1.1. If an immediate approach and landing are not feasible, state intentions, complete the After Takeoff Checklist and proceed as planned.

17.15.12.1.2. If an immediate landing is feasible and desired, the PF will announce intentions and maneuver to a VFR pattern. Maneuver the aircraft to be wings level and configured at a minimum of 300 feet AGL and 1 NM final for an SCA or visual approach. Pilots will call the zone “in sight” as they turn final and CSO will make standard altitude advisory calls on descent. (T-3)

17.15.13. Loss of NVGs:

17.15.13.1. Before Landing. If the pilot or copilot loses use of their NVGs inside of 1 NM, perform a go-around.

17.15.13.2. After Takeoff. The PF should transfer aircraft control and continue the climb out. Consider transitioning to instruments or overt lighting.

17.15.13.3. On the Ground. The PF will determine whether to continue the landing rollout or takeoff roll as applicable. (T-3) The PM should be prepared to turn on overt lighting at the direction of the PIC in case of NVG failure during takeoff or landing roll.

## 17.16. Airdrop Operations.

17.16.1. General Airdrop.

17.16.1.1. Each CSO performing an airdrop will compute a CARP/HARP. (T-3)

17.16.1.2. The CSO will plot and brief the CARP/HARP location on a drop zone mosaic. (T-3) Drop Zone mosaic will be annotated with run-in course, CARP/HARP location, load type/weight/chute, total time of fall, visual references (as required), red light location, 10-second location, ballistic winds, drop safety box, and escape/racetrack. (T-3)

17.16.1.3. Airdrops will normally be system-directed drops backed up by the pilots and CSO.

17.16.1.4. Airdrops may be conducted in IMC or VMC. For detailed information on DZ sizes, markings, types, weather, and wind limits, refer to AFI 13-217. For information on aerial delivery airspeeds, altitudes, and computations refer to AFI 11-231.

17.16.1.5. Airdrop Kits. The loadmaster will refer to the Loadmaster Procedures (**Chapter 13**) of this manual for items contained in airdrop kits. (T-3)

17.16.1.6. Specific in-flight visual signals, verbal signals and interphone procedures between the jumpmaster and loadmaster must be coordinated during the jumpmaster briefing. (T-3)

17.16.1.7. Required Navigation Accuracy. The navigation accuracy required for a given mission will vary depending on the type of mission and other considerations. For airdrops, to provide an early indication of degraded navigation accuracy, set the POS ALERT(s) at 0.03 NM (~ 55 yards; FOM 2) and 0.05 NM (~ 110 yards; FOM 4). Normally, airdrop accuracy requirements (300 yard Computed Air Probability) are met if the ship solution is FOM 4 or better and no POS ALERT is indicated. If these conditions are not met, further action (radar or visual cross-check/update) is necessary to verify/improve navigation accuracy prior to performing airdrops.

17.16.1.8. Minimum en route time from takeoff to TOT at release point will be sufficient to safely accomplish all required checklists. For airdrop involving personnel, the jumpmaster must approve en route time of less than 25 minutes. (T-3)

17.16.1.9. **Jumpmaster Directed Airdrop (JMD).** JMD personnel airdrops require OG/CC approval. The OG/CC may delegate to the unit or mission commander. The user accepts all responsibility for airdrop accuracy and damage to equipment or injury to personnel.

17.16.1.9.1. During JMD, the jumpmaster determines the release point (RP) mathematically or by wind drift indicator. The jumpmaster directs the aircraft to the RP using steering commands to the aircrew. CSOs will accomplish CARP or HARP calculations to back up the computations and in-flight directions given by the jumpmaster. (T-3)

17.16.1.10. JMD drops are limited to single-ship airdrop operations only. The following conditions apply:

17.16.1.10.1. After the slowdown checks are completed, the loadmaster permits the jumpmaster access to the door to begin "spotting procedures." The slowdown should be adjusted to allow the jumpmaster to begin spotting procedures at least two minutes out from the HARP. The jumpmaster visually relays steering signals to the loadmaster, who verbally relays these signals to the pilot. The jumpmaster may spot from the aircraft ramp or a paratroop door.

17.16.1.10.2. Upon entering the leading edge of the updated Launch Acceptability Region (LAR) (or as coordinated with the Jumpmaster), the PM may turn on the green light to indicate clearance for the jumpmaster to make a final decision as to the exact exit point. Jumpers may exit on the jumpmaster's direction while the green light is illuminated. The red light is turned on at the end of the CSO's computed usable DZ distance (or green light time) or when the last jumper or load exits, whichever occurs first. No jumpers should exit after the red light is turned on.

17.16.1.10.3. JMD releases will not be mixed with any other type of airdrop method, i.e., Ground Marker Release System (GMRS), Visual Indicator Release System (VIRS), or standard Computed Air Release Point (CARP) drops. (T-2) If JMD drop procedures are utilized, the crew will follow the jumpmaster's instructions, while adhering to normal safety concerns. Should the crew believe the drop would occur

outside of safe parameters, they will call “no drop” and ensure the red light is illuminated. (T-2)

#### 17.16.2. Airdrop Planning.

17.16.2.1. Crews will not perform airdrops using parachutes which AFI 11-231 does not list ballistics or MAJCOM/A3V has not approved. (T-2) This does not apply to formal test missions where the purpose of the test is to derive ballistic data for a specific load.

17.16.2.2. The PIC and the CSO will review the DZ survey during mission planning. (T-3)

#### 17.16.3. Airdrop Communications Procedures.

17.16.3.1. During airdrop, after acknowledgement of the 20-minute warning and donning of the helmet, loadmasters may clear off interphone, with the PIC’s approval, to facilitate movement around large platforms or CDS loads. The CSO will accomplish the brief associated with the 20-minute warning. (T-3) After completing the required 20-minute checklist items, the primary loadmaster will remain on interphone throughout the remainder of the airdrop. (T-3)

17.16.3.2. Training Operations. Limit radio transmissions with the DZ to those required for safety of flight considerations or factors affecting airborne force employment. This includes ATC directions, range clearance, unsafe surface conditions or mission changes. When a dropping to a manned DZ, aircrew will obtain verbal clearance to drop from the DZ controller unless alternate clearance procedures were previously coordinated. When the mission dictates radio silence, transmission of wind information and range or drop clearance is not required. Radio silent DZ operations will be coordinated prior to mission execution. (T-3)

17.16.3.3. Drop clearance is normally inherent with mission clearance to unmanned DZs. The aircrew observing the proper briefed authentication confirms drop clearance in VMC.

17.16.3.4. In VMC, a no-drop or mission cancellation is communicated by the absence of prebriefed markings (visual or electronic), jumbled block letter, observation of the block letter X, or red smoke, light, flare, or as briefed.

17.16.3.5. In IMC, drop clearance is confirmed via radio call or beacon acquisition. In IMC, a no-drop or mission cancellation is communicated by an authenticated radio transmission or absence of the beacon.

17.16.4. Ramp and Door and Paratroop Door Operations. **WARNING:** The ramp and door and paratroop doors will not be open at the same time. (T-2) High speed operations with the paratroop doors open will not be accomplished during training missions. (T-2)

17.16.4.1. Air Deflector Doors. If an air deflector door cannot be opened, its respective paratroop door will not be used. (T-2)

17.16.4.2. Clearance to Open. The PIC may direct ramp and door opening any time after the Six-minute advisory for personnel drops, or as mission requirements dictate for non-personnel drops. After the ramp and door are open, the loadmasters are cleared to complete their slowdown checklist.

- 17.16.4.2.1. High-Speed Low-Level Delivery System (HSLADS)/ Extracted Container Delivery System - High Speed (XCDS-HS). The pilot may direct the CSO to call the three-minute warning as early as mission requirements dictate. This option must be planned and pre-briefed prior to execution. Consider added drag, power available, climb requirements, built up areas, airdrop rigging and the possibility of dropped objects when the door is opened.
- 17.16.4.3. **WARNING:** Do not open the ramp and door to accomplish SATB/simulated airdrops with loads rigged with an extraction parachute in the bomb rack or HSLADS sling attached. (T-3) If the actual airdrop loads cannot be dropped, the extraction parachute will be removed from the bomb rack and secured forward of the load and HSLADS slings will be disconnected. (T-3)
- 17.16.4.4. Loadmaster-Jumpmaster Control. After completion of the Slowdown Checklist, the primary loadmaster will relinquish control of the paratroop doors/ramp and door to the jumpmaster. (T-2) The loadmasters will then take a position on the cargo ramp in such a manner as to provide maximum maneuverability for jumpmasters and safety personnel to perform their duties. (T-2) For ramp and cargo door exits, the loadmaster(s) will take a position to prevent interference with exiting jumpers. (T-2) Upon seeing the red light illuminate, the primary loadmaster will notify the jumpmasters or safety personnel of the red light condition. (T-2) The loadmaster will take no further action to stop any of the remaining parachutists. (T-2) The loadmasters will count (if possible) any parachutists that exit the aircraft after the red light has illuminated. (T-2) Control of the paratroop doors/ramp and door will revert back to the loadmasters after all parachutists have exited or remaining parachutists have been stopped by the jumpmaster or safety and cleared from the door area. (T-2) For multiple passes (racetracks), after assuming control of the paratroop doors/ramp and door from the jumpmaster, the loadmasters will maintain control of the doors until completion of subsequent Slowdown Checklists. (T-2) **WARNING:** During personnel airdrops, the loadmasters will not position themselves directly under the aft anchor cable supports (A-Frame, FS 737). (T-2) **WARNING:** Ensure all personnel aft of FS 737 are secured to the aircraft or have a static line connected prior to opening the ramp and door. HALO/High Altitude High Opening (HAHO) personnel must be configured and ready to jump.
- 17.16.4.5. Multiple Passes/Racetracks. When performing multiple equipment airdrops across the same DZ, all airdrop checklists will be accomplished. (T-2) When performing multiple personnel drops across the same DZ, checklists may resume at the 6 minute advisory assuming no airdrop parameters or aircraft configuration changes are made from the previous drop. Ensure the loadmaster has adequate time to complete all checklist items before the drop. (T-3) **Exception:** During non-JMD airdrops, the checklist may be initiated at a point commensurate with the available time and type of drop. This will be coordinated at the Pilot/ Loadmaster/Jumpmaster/Troop Commander Briefing. (T-2) When airdrop parameters or aircraft configuration changes are made between drops, all checklists will be accomplished. (T-2) Airdrop time advisories and checklists may be compressed, except for the one minute warning. Doors may remain open at the discretion of the PF.

17.16.5. Tailgate Drops. The following restrictions apply:

17.16.5.1. Rig both anchor cables and both static line retrievers prior to takeoff (if applicable).

17.16.5.2. Use one anchor cable for each pass and limit each pass to a maximum of 20 static lines (19 personnel with a CRRC or 18 with a RAMZ).

17.16.5.3. Use the opposite anchor cable if another pass is required.

17.16.5.4. Retrieve static lines and deployment bags prior to each additional pass.

#### 17.16.6. Airdrop Execution.

17.16.6.1. Positioning. Accurately positioning the aircraft at the release point is the most critical phase of the airdrop mission. Crew coordination is of the utmost importance to ensure that all checklists are completed, proper DZ line-up is maintained.

17.16.6.2. System/Visual Airdrops. The primary method for aerial delivery is automatic release at the computer derived release point. Visual Airdrops are authorized.

17.16.6.3. CSOs will update the jumpmaster in-flight on actual wind information and any changes to the crew's preflight computed CARP/HARP location. (T-3) The crew will also update the jumpmaster with the local altimeter setting for the planned drop zone (if available) at the 10minute warning. (T-3) The jumpmaster will reconfirm this setting with the aircrew. (T-3)

17.16.6.4. Approved computer-aided CARP and HARP software may be used, but the CSO must verify the results. (T-2)

17.16.6.5. The CSO will verify the actual number and type of parachutes, load weights, sequence of delivery, and position of loads in the aircraft. Recalculate CARP/HARP if actual conditions differ from the preplanned configuration. (T-3) **WARNING:** Military CYPRES Automated Activation Devices (AADs) require both a descent below 1,500 feet AGL and 115 feet per second (6900 VVI) descent rate threshold before it will deploy the reserve parachute. Jumpmasters will program the CYPRES in flight if en route time exceeds one hour to the drop zone, and require an accurate local altimeter setting to do so. A programmed altimeter setting significantly different from the actual local altimeter can result in unintended deployment of the reserve canopy or failure to deploy when needed, endangering Military Free-Fall (MFF) personnel. Use of auto-pressurization can also cause activation of the CYPRES AAD just after take-off in certain situations.

17.16.6.6. Safety Device. Provide safety personnel with parachutes carried on board the aircraft. They may use a restraint harness at their discretion, if available. Provide a restraint harness to other personnel required to be mobile in the cargo compartment.

17.16.6.7. A DD Form 1748, *Joint Airdrop Inspection Record*, will be accomplished prior to all equipment airdrops. (T-2) Completion, retention and disposition of the form will be in accordance with the AFJ 13-210(I), as supplemented. (T-3) **Exception:** A-7A and A-21 containers rigged for door bundles. The aerial delivery unit supporting movement of equipment and supplies will ensure current publications are available to the loadmaster to ensure standardization of joint inspections. (T-3) Aerial delivery units supporting MC-130J unilateral airdrop training will provide copies of required publications. (T-3)

17.16.6.8. In-flight Rigging Procedures. In-flight rigging is a safe procedure if accomplished under a controlled situation. Accomplish in-flight rigging only when the safety of the personnel required to be mobile in the cargo compartment is not jeopardized. The aircraft may have to depart the formation or change altitude. Use the following procedures on airdrop missions that require in-flight rigging:

17.16.6.8.1. Two loadmasters are required, except for SATB. At least one loadmaster will remain on interphone at all times. (T-3) When only one loadmaster is assigned to the crew and in-flight rigging of an SATB is required, a crew member on interphone will observe the in-flight rigging from a forward position in the cargo compartment. (T-3)

17.16.6.8.2. The use of a pendulum rigging step is optional.

17.16.6.8.3. Make an in-flight check of the rigged items using the DD Form 1748. **WARNING:** For personnel airdrops, the pilot must be aware of paratroopers standing and avoid drastic pitch, bank, and power changes after the Ten Minute Warning. (T-3) Use of autothrottles may cause drastic speed changes resulting in an unstable platform.

17.16.6.9. Airspeed adjustments should be completed prior to slowdown.

17.16.6.10. If the IP is visible from a distance and time control permits, overfly the IP on run-in heading. Otherwise, fly a curved-path leg to the DZ. If required, update navigation equipment at the IP.

17.16.6.11. After departing the IP, the PM assists the CSO in maintaining the desired track inbound by confirming aircraft position with the planned run-in update points.

17.16.6.12. The CSO provides headings that will position the aircraft the required distance upwind from centerline track so that large corrections will not be required on the final approach to the release point. (T-3)

17.16.6.13. Slowdown Procedures. During airdrop operations, the CSO will direct the slowdown maneuver at a predetermined point. (T-3) Begin slowdown at a distance commensurate with aircraft performance and proficiency of the crew. Decrease slowdown distance as proficiency increases and the threat dictates. If known threats are in the objective area, decrease the slowdown distance to reduce the time the aircraft is vulnerable at drop altitude and airspeed. After the CSO calls for the slowdown: (T-3)

17.16.6.13.1. The PF normally retards the power levers to flight idle.

17.16.6.13.2. The PM lowers the flaps on speed.

17.16.6.13.3. For paratroop door drops, the PM opens the air deflector doors upon slowing below 150 KCAS. Once air deflector doors are called open, this automatically clears the LM to open the paratroop doors.

17.16.6.13.4. For tailgate drops, the CSO will call “30-seconds to slowdown—DOORS” as part of the 30-second warning, followed by the PF stating “clear to open”, the LM opens the cargo door and ramp.

17.16.6.13.5. For CDS drops, reset the flaps IAW the CDS flap setting chart.

17.16.7. Airdrop Execution. During the final seconds of the approach to the release point, the PM places a hand near the jump light switch when the computer drop switch is in Manual and on the computer drop switch when either Auto or AD Man/TJ Auto is selected. At the CSO's "10 seconds" call, if the aircraft location is not within pre-coordinated parameters, a "no-drop" condition exists.

17.16.8. The loadmaster will not deploy equipment or personnel until hearing and seeing the green light. (T-2) If mission dictates during contingency operations, aircrews may coordinate for loadmasters to only require visual or aural green light confirmation.

17.16.9. IMC Airdrop.

17.16.9.1. IMC Drop Altitude. Plan minimum IMC drop altitudes at MSA or as specified in AFI 11-231, whichever is higher.

17.16.9.2. IFR Drop Corridor. IFR Drop Corridor will be calculated out to 3 NM either side of run-in centerline from DZ entry point to DZ exit point. (T-3) **Note:** Crews may segment drop corridor MSAs as mission requirements dictate.

17.16.9.2.1. DZ Entry Point. The DZ entry point is a fixed point on DZ run-in course where an aircraft or formation of aircraft may safely begin descent from IMC en route altitude to IMC drop altitude. The DZ entry point is a maximum of 40 NM prior to the DZ exit point according to FAA FAR exemption 4371C. (T-3) **WARNING:** Analyze pre-drop gross weight to determine if obstructions can be cleared on three-engines from DZ Entry through DZ Exit. If obstructions cannot be cleared, adjust the number of aircraft, reduce aircraft gross weight, revise run-in and/or escape course, or increase drop altitude.

17.16.9.2.2. DZ Exit Point. The DZ exit point is a fixed point on the DZ escape flight path centerline, established during pre-mission planning, at which the formation will be at the minimum IMC en route altitude. Calculate the exit point based upon three-engine performance at airdrop gross weight. This point will be planned no less than 4 NM track distance beyond the DZ trailing edge. (T-3)

17.16.10. Visual Airdrops. Visual Airdrops are authorized in the MC-130J.

17.16.10.1. When conducting visual airdrops, the primary method is to use visual reference points to identify the CARP. Alternatively, crews may use sight angle timing to identify the CARP. Using visual reference points requires in-depth mission planning and crew coordination.

17.16.10.1.1. During pre-mission planning crews will select visual reference points from the initial point through escape. On the airdrop run-in, a minimum of three visual reference points will be selected that aid in acquisition of the drop zone and help in offset alignment. (T-3) Several visual update points should be identified on the drop zone to aid in timing, CARP location and Safety Box dimensions. Visual reference points should be either directly in front of or abeam the aircraft to provide optimum offset and timing. Run-in visual reference points should be used in conjunction with timing advisories or checklist calls to the maximum extent possible. All visual reference points and the airdrop safety box will be briefed during the pre-mission crew brief. (T-3)

- 17.16.10.1.2. In flight, crews will identify and call out visual references to aid in drop zone alignment and verify system accuracy (if applicable). (T-3) The first crew member to have the drop zone in sight will state "Drop Zone in sight." (T-3) The second crew member to have the drop zone in sight will call out clock position and distance to the drop zone. (T-3) The third crew member to have the drop zone in sight will state "Confirmed, Drop Zone in sight." (T-3) The CSO will be the primary crew member responsible for airdrop timing and calling "Green Light." (T-3) Visual reference points at or near the 10 second call and green light will help in airdrop timing and accuracy. (T-3) The PF will be responsible for lateral and vertical aircraft alignment and ensuring the aircraft is in a safe position to execute the drop. (T-3) The PM will back up the CSO timing and verify the aircraft is in the airdrop safety box by stating, "In the safety box." (T-3) Any changes or updates to the visual reference points, CARP and safety box will be briefed to the crew. (T-3)
- 17.16.10.2. During training, crews will use visual airdrop procedures in conjunction with system airdrop procedures. (T-3) Crews will determine and brief visual airdrop tolerances and the airdrop safety box. (T-3) At a minimum, use a +/- 2 second tolerance for the 10 second call (20 seconds for a tow plate) and +/- 150 yards lateral offset of CARP location compared to system airdrop guidance in order to verify visual airdrop CARP accuracy. Using visual airdrop procedures does not supersede existing airdrop procedures and requirements.
- 17.16.11. No-Drop Decisions. In addition to TO 1C-130(M)J-1 No-Drop conditions:
- 17.16.11.1. Prior to the 1- or 2-minute (for high-altitude) warning, notify the PIC when any condition exists that could jeopardize a safe drop.
- 17.16.11.2. After the 1- or 2-minute (for high-altitude) warning, any crew member observing a condition that would jeopardize a safe drop will transmit "No-drop" on the interphone. (T-2)
- 17.16.11.3. The PM, CSO and Loadmaster will acknowledge the "No-drop" call. (T-3) The PM will place the computer drop switch to Manual to prevent automatic release of the load. (T-3)
- 17.16.11.4. Stopping a Drop in Progress. Any crew member recognizing an unsafe condition during an airdrop will state "red light." (T-3) The PM will turn on the red light to signal the airdrop termination. (T-3)
- 17.16.11.5. On personnel airdrops where surface winds are unknown, (such as unmanned DZs) advise the jumpmaster and Army airborne mission commander when drop altitude winds exceed 30 kts. In this instance, the decision to drop is at user's discretion.
- 17.16.12. Departure from DZ (Escape). The CSO will call "red light" at the expiration of the "green light" time or upon hearing "load clear." (T-2) The PM will activate the red light upon hearing the CSO's call. (T-2) When the LM calls "load clear," immediately begin the escape maneuver by tracking flaps as required, turn to the departure heading, and climb or descend to the escape altitude. (T-3) Do not exceed 140 KCAS (except HSLLD/SCDS-HS) until the static lines are retrieved to facilitate static line retrieval and preclude entanglement. Close all doors, raise flaps, and accelerate to en route airspeed. It is imperative that the aircraft be configured for high speed evasive maneuvers. Therefore, after the static lines have been



retrieved or cut, the doors and air deflectors closed, and flaps raised, the remainder of the post-drop checklist may be deferred to a more convenient time while returning to the recovery base. The Loadmaster will call "Bags In" to notify the crew the deployment bags have been retrieved. (T-3) **WARNING:** Coordination between the PF and Loadmaster should be accomplished prior to the airdrop to prevent injury of aircrew in the back of the aircraft once the power levers are advanced to max power for the escape.

17.16.13. Static Line Retrieval. Loadmasters should allow a few moments for static lines to wrap together before retrieving static lines. Designated aircrew members will retrieve static lines as soon as possible after parachutist or bundle exit is completed or exiting is suspended. During combat, static lines that cannot be retrieved will be cut so doors can be closed. (T-3) If the static line retriever fails, static lines will be manually retrieved using a tie-down strap as follows. (T-3) **Note:** A maximum of ten static lines may be retrieved manually per paratroop door. A maximum of 20 static lines per cable may be retrieved with a static line retriever winch.

17.16.13.1. Static Line Retriever alternate recovery procedures. The following procedures will be used when the Static Line Retrieval System is unavailable: (T-3)

17.16.13.1.1. Paratroop Door.

17.16.13.1.1.1. Secure the hook end of a cargo strap to a point far enough forward in the cargo compartment to allow static lines to completely enter the aircraft.

17.16.13.1.1.2. Insert the other end of the cargo strap from the bottom up, making a "U" around the static lines.

17.16.13.1.1.3. Pull the strap forward to retrieve the static lines into the aircraft. Loadmasters may require assistance to pull the strap forward.

17.16.13.1.2. Ramp and Door.

17.16.13.1.2.1. If the static line retriever fails following a combination/ tailgate drop, use the Prusik Knot as described below. Refer to **Figure 17.8 Prusik Knot**.

17.16.13.1.2.2. Take a 30 inch piece of 1/2-inch tubular nylon cord that is tied in a loop. Loop the cord around the static line retriever cable as shown in the figure. Use a minimum of three wraps around the retriever cable to ensure locking of the 1/2-inch tubular nylon cord.

17.16.13.1.2.3. Pull to tighten the knot around the retriever winch cable to prevent slipping. Attach the hook end of a 5,000 pound strap into the loop's end and pull in the static lines. The 1/2-inch tubular nylon cord will remain locked in place under tension. (T-3)

17.16.13.1.2.4. More than one 1/2-inch tubular nylon cord may be attached to the winch cable using the Prusik Knot to facilitate static line retrieval. The Prusik Knot may be adjusted up or down the cable as required. The knot will not slip as long as it is wrapped tightly with a minimum of three turns (more wraps equal more friction), and tension is applied.

17.16.13.1.2.5. To prevent cutting the 1/2-inch tubular nylon cord with the hook on the 5,000-pound strap, a carabineer may be attached to the 1/2-inch tubular nylon

cord loop and the hook attached to carabineer.

**Figure 17.8. Prusik Knot.**

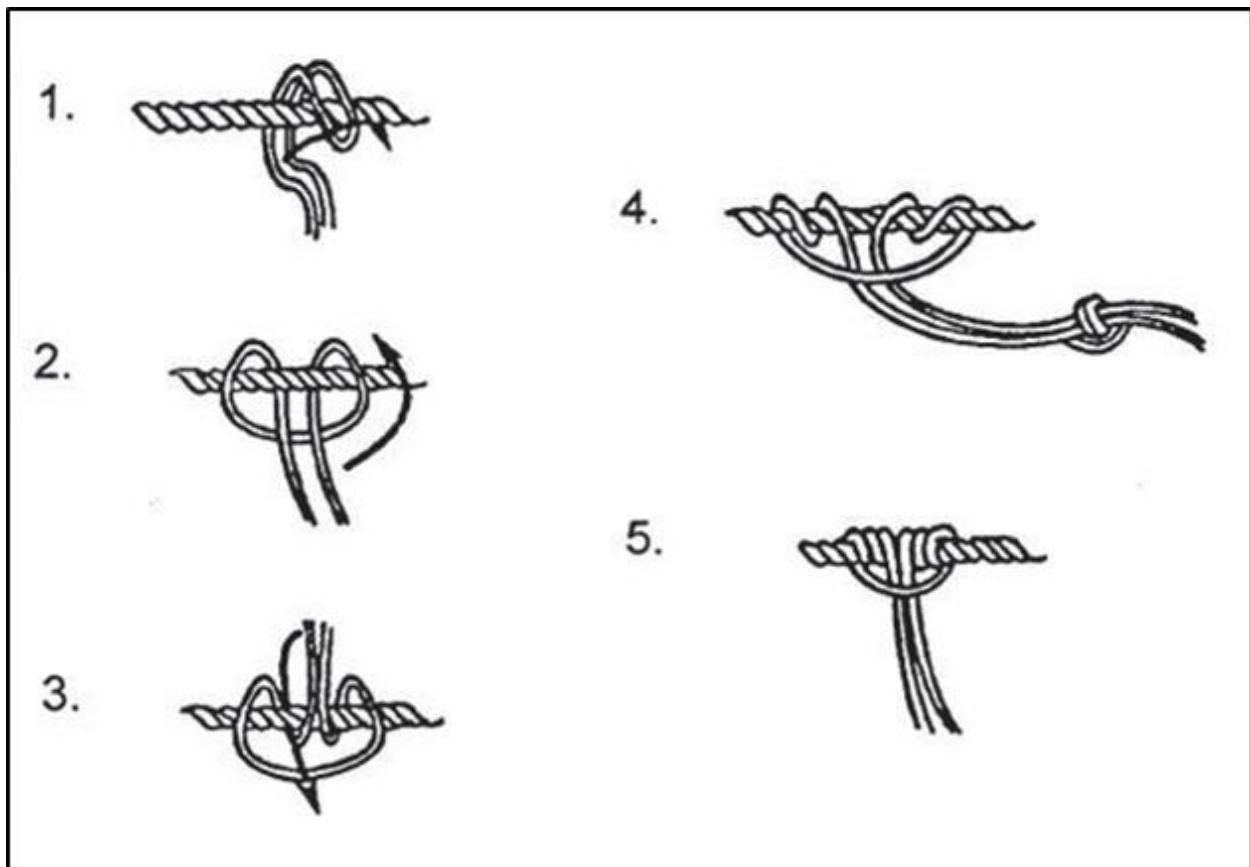

17.16.14. Airdrop Malfunction and Emergencies. Specific emergency procedures for each type airdrop are located in the TO 1C-130(M)J-1 checklists, or appropriate MAJCOM-approved guidance. After all appropriate emergency actions are complete, accomplish the COMPLETION OF DROP checklist. **Note:** Prior to stations time, the pilot will ensure all crew members have reviewed the emergency procedures for the proposed airdrop. (T-3) The aircrew will conduct detailed emergency briefings. (T-3) Loadmasters will brief visual and verbal signals and establish coordinated tasks for their crew position prior to the first airdrop warning. (T-3)

17.16.15. Combination Drops. Combination drops are when parachutists exit after the airdrop load. The item requiring the highest altitude will determine the drop altitude. (T-2)

17.16.15.1. Restrictions. A maximum of 20 personnel static lines may be deployed on each pass and only one anchor cable will be used for these static lines. Static lines for equipment will be attached to opposite anchor cables and must be rigged for breakaway. (T-2) **Exception:** When airdrop loads are rigged with pilot chutes packed in T-10 bags, they will be attached to the same anchor cable as personnel. Maximum static lines per cable are 20. Static lines will be retrieved after each pass. (T-3)

17.16.15.2. Procedures. In addition to the equipment CARP, the CSO will compute a personnel CARP down track from the equipment release point using the computed exit

time for the equipment drop as the interval between the equipment and personnel CARP. (T-3) Use the same airspeed and altitude as for the equipment for this computation. If the computed release point will result in any jumper landing within 150 yards of any boundary of the DZ, inform the jumpmaster. Release the equipment at the equipment CARP, followed by the parachutists when the door is clear. **Exception:** For door and ramp bundles, use release points as specified in **Paragraph 17.16.23.1**.

17.16.16. Low-Altitude Airdrops. For detailed information, refer to AFTTP 3-3.E/MC-130J. Refer to the expanded checklist for normal and emergency airdrop procedures.

17.16.17. High-Altitude Airdrop Procedures. Airdrops conducted above 3,000 feet AGL are considered high-altitude drops.

17.16.17.1. High-Altitude Mission Requirements. In addition to the normal mission planning requirements, the following are unique to high-altitude operations:

17.16.17.2. Cabin differential pressure will be managed to have cabin altitude equal to the ambient pressure prior to completion of the 10-minute checklist. Depressurization will not exceed 3,000 feet per minute. (T-3) Pressurization after the drop will be maintained in accordance with mission requirements, but should return to a cabin altitude commensurate to the flight profile and duration as detailed in AFI 11-202, Vol 3, or below 10,000 feet MSL as soon as possible. (T-2)

17.16.17.3. High-Altitude Oxygen requirements. Only essential personnel should be carried on mission aircraft during airdrop operations. AFI 11-202, Vol 3, is the source document for oxygen requirements for unpressurized and pressurized aircraft operations and the associated time limitations. AFI 11-409 is the source document for high-altitude oxygen, pre-breathing and Physiology Technician (PT) requirements/restrictions.

17.16.17.4. Incident Notification. Air Force Office of Aerospace Medicine (AF/SGPA) and MAJCOM Surgeon General (MAJCOM/SG) will be notified by the most expeditious manner of any physiological incident. (T-2)

17.16.17.5. General Emergency Procedures. If any person experiences decompression sickness or unusual pain, the pilot will: (T-3)

17.16.17.6. Abort the mission and begin a descent (pressurization and descent will be determined by the type and degree of sickness or pain).

17.16.17.7. Proceed to the nearest base at which qualified medical assistance is available. Advise the control tower of the emergency and request a flight surgeon and an ambulance to meet the aircraft.

17.16.18. Personnel Drops. Normally, aircrew will maintain 130 knots indicated airspeed KCAS plus or minus 5 KCAS for all personnel static line and combination drops. **Note:** For all airdrops, crews should give careful consideration to the performance parameters of all associated airdrop equipment and parachutes to ensure the safest possible margins are maintained.

17.16.18.1. Aircraft Configuration. The loadmaster will ensure the configuration of the anchor cables and seats are consistent with the number of personnel to be airdropped. (T-3) During aircraft preflight, the loadmaster will ensure that all seats have a serviceable retaining strap attached. (T-3) Fit seats without a serviceable retaining strap with a suitable

length of type III nylon, premeasured for sufficient length to secure the seat in a raised position to the seat back support frame. For single pass drops, ensure that parachutists have secured all seats (as required) and no part of the seat protrudes into the aisle. On multiple passes, the number of parachutists to be dropped on that pass determines the number of seats raised. Troop seats will be raised and secured, or lowered, as required, by personnel under the supervision and instruction of the loadmaster. (T-3) Floor loading is authorized in accordance with **Chapter 6 Airland Operations**.

17.16.18.2. Aircraft Emergency During Personnel Airdrop. When an aircraft emergency occurs during or after the time the parachutists stand and hookup, the following procedures will apply: (T-3)

17.16.18.2.1. Under acceptable conditions when parachutists bailout is required, maintain an acceptable altitude and attitude for the parachutists to evacuate the aircraft. The minimum acceptable altitude is as briefed. If the jump airspeed will be in excess of 150 KCAS, advise the parachutists of the airspeed and altitude. Order evacuation of the aircraft by giving the pre-briefed bailout emergency signals.

17.16.18.2.2. When conditions are not acceptable for parachutists bailout or a drop is aborted for other reasons, the following procedures apply:

17.16.18.2.2.1. The red light will be turned "ON" and will remain on until exit doors are closed. (T-3)

17.16.18.2.2.2. The PF will advise the loadmaster, who in turn will advise the jumpmaster to have the parachutists unhook, take their seats and fasten safety belts. (T-3)

17.16.18.3. Center Stick Targeting for personnel. When performing static line personnel airdrops using center stick targeting procedures, crews will use the average weight of personnel in the stick for CARP computation purposes. (T-3)

17.16.18.3.1. Use the position of the center jumper in the stick for determining exit time, based on a one-second exit time for each jumper. For example, if there are 8 jumpers in the stick, "Green Light" would be called 3 seconds early for the fourth jumper to land on the PI.

17.16.18.3.2. Minimum DZ size will be IAW **Table 17.3**. (T-2) When center stick targeting on an existing surveyed DZ, crews will ensure that the entire center stick targeting DZ fits within the boundaries of the original surveyed DZ. (T-2)

17.16.19. Equipment Airdrops. Only equipment rigged in accordance with TO 13C7-series or USSOCOM rigging manuals, properly marked with accurate weights and shipper's declarations will be airdropped. (T-2) Nonstandard equipment and loads require specific instructions and waivers from MAJCOM/A3V prior to airdrop.

17.16.20. Container Delivery System (CDS). Container delivery system is designed to airdrop A-7A, A-21, A-22, Stretch A-22, Double A-22, and LCADS containers and loads rigged on combat expendable platforms. The weight of each container and type parachute used should be IAW TO 13C7-1-11, *Airdrop of Supplies and Equipment: Rigging Containers*, or USSOCOM rigging manuals.

17.16.20.1. CDS rigging procedures. Utilize rigging procedures outlined in TO 1C-130J-9. The following describes the types of CDS releases that may be used on MC-130J aircraft.

17.16.20.2. Normal System Release. A normal system release utilizes the static line retriever and guillotine knife to cut/release the CDS gate. When using this method, the loadmaster may assist the release by pulling down sharply on the static line retriever winch cable.

17.16.20.3. Manual Gate Cut. A manual gate cut is defined as using a knife or V blade type knife to cut/release the CDS gate for all container loads. Loads rigged with type XXVI/VIII nylon may be manually cut using these procedures.

17.16.20.4. Escape. Departing the DZ, set flaps to 50 percent, accelerate to en route airspeed, climb or descend as briefed, and perform the completion of drop checklist. Flaps may be called up at the discretion of the PF in lieu of going to 50 percent.

17.16.20.5. Center Stick Targeting. Center Stick Targeting, also known as “Bracketing the PI” is authorized for all CDS airdrops (including HVCDS, LCADS-LV, LCADS-HV, CRS, CRL, HSSLADS, LCLA, and XCDS-HS/LS).

17.16.20.5.1. Crews will coordinate with the DZ controller to ensure that the appropriate object is scored when using center stick targeting procedures. (T-3)

17.16.20.5.2. Minimum DZ size will be IAW [Table 17.3](#). (T-2) When center stick targeting on an existing surveyed DZ, crews will ensure that the entire center stick targeting DZ fits within the boundaries of the original surveyed DZ. (T-2)

17.16.20.5.3. When performing CDS, HVCDS, LCADS-LV, or LCADS-HV using center stick targeting procedures, crews will use the average weight of the stick for CARP computation purposes. (T-3) Use the flight station position of the center of the stick for determining exit time. While this flight station and weight may not correspond exactly to any single bundle within the stick, the method provides the most accurate CARP computation.

17.16.20.5.4. When performing LCLA, CRS, CRL, HSSLADS or XCDS-HS/LS, using center stick targeting procedures, crews will use the average weight of the stick for CARP computation purposes. (T-3) Use the exit time from current applicable guidance.

Table 17.3. Center Stick Targeting Minimum DZ Size.

ALTITUDE (AGL)	WIDTH	LENGTH			
<b>C-130 CDS/CRS/CRL/LCADS-LV/LCLA</b>					
To 600 feet	400 yds/366m	Single Containers	Double Containers	Length Prior to PI	Length Past PI
		1	1-2	200 yds/183m	200 yds/183m
		2	3-4	225 yds/206m	225 yds/206m
		3	5-6	250 yds/229m	250 yds/229m
		4	7-8	275 yds/252m	275 yds/252m
		5-8	9-16	350 yds/320m	350 yds/320m
		9-12	10-24	425 yds/389m	425 yds/389m
Above 600 feet	Add 40 yds/36m to width and length for each 100 feet above 600 feet (add 20 yds/18m to each side of DZ, 20 yds/18m to each end).				
<b>HVCDS (using 12, 22, or 26 foot ring slot parachutes) / LCADS-HV</b>					
To 3000 feet	580 yds/530m	Length Prior to PI		Length Past PI	
		300 yds/204m		330 yds/204m	
		Add 25 yds/23m to leading edge for each additional row of containers		Add 25 yds/23m to trailing edge for each additional row of containers	
Above 3000 feet	Add 25 yds/23m to each side and 100 yds/91m to each end for every 1000 feet increase in drop altitude.				
<b>HSLLDAS/XCDS-HS/LS</b>					
All	300 yds/274m	Length Prior to PI		Length Past PI	
		300 yds/275m		300 yds/275m	
<b>Personnel (Static Line)</b>					
To 1000 feet	600 yds/549m			Length Prior to PI	Length Past PI
		1 Parachutist		300 yds/275m	300 yds/275m
		Additional Parachutists		Add 38 yds/35m to the leading edge for each additional parachutist. Add additional 200	Add 38 yds/35m to the trailing edge for each additional parachutist. Add additional 200
			yds/91m to leading edge for safety zone, if required	yds/91m to trailing edge for safety zone, if required	
Above 1000 feet	Add 30 yds/28m to width and length for each 100 feet above 1000 feet (add 15 yds/14m to each side of DZ, 15 yds/13m to each end).				

17.16.21. Heavy Equipment (HE) Drops. Only equipment rigged in accordance with TO 13C7-1-5, *Airdrop of Supplies and Equipment: Rigging Airdrop Platforms* or USSOCOM rigging manuals will be airdropped. (T-2) Nonstandard equipment and loads require specific instructions and waivers from MAJCOM/A3V prior to airdrop.

17.16.22. Door Bundle. A7A or A-21 containers weighing up to 500 pounds are referred to as door bundles and may be dropped through the paratroop door or ramp and door using the personnel airdrop checklist. Door bundles may be dropped independently or in conjunction with personnel. Bundle airdrops are limited to one bundle per paratroop door. When dropped with personnel, the bundle will be the first object to exit the aircraft. (T-2) The maximum bundle size in inches is 66 (height) x 48 (width) x 30 (length) for paratroop door loads. Joint Airdrop Inspection (JAI) is not required for door bundles.

17.16.22.1. Paratroop Doors (Personnel Checklist). Remove restraint and position the bundle in the paratroop doors prior to completion of the slowdown checklist. Ensure door bundles are not equipped with breakaway static lines.

17.16.22.2. Ramp and Door Bundle (Personnel Checklist). Door bundles dropped off the ramp and door will be equipped with breakaway static lines in accordance with TO 13C7-1-11, *Airdrop of Supplies and Equipment: Rigging Containers*, or with parachutes packed in T-10 bags. (T-2) Ramp bundles will be rigged in accordance with TO 13C7-1-11 or USSOCOM directives and dropped as on-the-ramp loads. Door bundles dropped from the ramp and door that exceed the weight or dimensions specified in [Paragraph 17.16.22](#) will be equipped with a skid board compatible with the intermediate roller conveyors. (T-2)

17.16.22.3. Release Point. When door/ramp bundles are dropped with personnel, compute a personnel CARP. Compute an additional CARP for the door bundle and plot the vectors from the personnel release point to ensure it will impact within the DZ boundaries. Release the bundle at the personnel CARP, followed by the parachutists when the door is clear. (T-3) When a door bundle is the only object being dropped, base the release on the CARP for the bundle.

17.16.23. Container Ramp Load (Personnel/CDS Checklist). The total rigged weight of the load will not exceed 2,335 lbs, unless specified in the applicable rigging TO. (T-2) CRL bundles will be rigged in accordance with TO 13C7-1-11 or USSOCOM directives and dropped as on-the-ramp loads. (T-2) Remove vertical and aft restraint at the 10-minute warning. Remove forward restraint prior to the completion of the slowdown checklist. The loads will be released by the loadmaster and may be followed by parachutists. (T-3) These procedures can be accomplished from either side of the cargo ramp or from centerline. Specific aircraft preparations and rigging procedures are contained in TO 1C-130J-9.

17.16.23.1. Release Point. When CRL bundles are dropped with personnel, compute a personnel CARP. Compute an additional CARP for the door bundle and plot the vectors from the personnel release point to ensure it will impact within the DZ boundaries. Release the bundle at the personnel CARP, followed by the parachutists when the door is clear. An alternate procedure is to add the exit time of the bundle to the personnel CARP, and release the bundle at this point, followed by the jumpers. If this method is used, the crew must coordinate with the user to ensure the load lands at the desired location. (T-3) When a CRL bundle is the only object being dropped, base the release on the CARP for the bundle. CSOs should use LCLA exit times for CRL bundles.

17.16.23.2. Only equipment rigged in accordance with TO 13C7-series or USSOCOM rigging manuals, properly marked with accurate weights and shipper's declarations will be airdropped. (T-2) Nonstandard equipment and loads require specific instructions and waivers from MAJCOM/A3TW prior to airdrop.

17.16.24. SATB Emergency Procedures. If a training bundle is outside and fails to separate, make no attempt to retrieve it. Cut the bundle loose over the pre-briefed salvo area or DZ. If the bundle falls on the ramp, close the cargo ramp and door. Do not attempt to remove the bundle from the ramp prior to closing the ramp and door. When shutting the cargo ramp and door, a hung bundle could become wedged in the aircraft elevator during turns. If possible, cut the static line prior to making a turn.

### 17.17. Formation Procedures.

17.17.1. General. Formation is used to get mass to an objective/target and facilitates escort/safe passage requirements. The need to get mass to an objective/target must be calculated against putting multiple aircraft in close proximity to each other. If the mission necessitates flying low level to deliver mass at an objective/target in minimum time, consider flying independent routes prior to the objective/target area.

17.17.1.1. These procedures are primarily designed to be used in VMC. IMC procedures may be employed in extraordinary circumstances when IMC is encountered inadvertently or when the mission demands that IMC must be penetrated. During training in an ATC environment, accomplish IMC formation IAW FAA or host nation procedures.

17.17.1.2. **WARNING:** Operation under VFR clearance in IMC conditions is an emergency procedure during training and exercise operations, requiring appropriate IFF and radio calls to the area air traffic control agency. During contingency or combat missions, the necessity of flying "comm-out" in IMC must be weighed against terrain clearance capability and the increased mid-air potential.

17.17.2. Ground operations. Minimum taxi interval is one aircraft length.

17.17.3. Takeoff. Minimum takeoff interval is 15 seconds. For simultaneous departures, aircraft separation must be at least 3,000 feet between aircraft. Lead must have at least 3,500 feet of useable runway for takeoff. Minimum visibility for formation takeoff is 1 mile (RVR 50).

17.17.4. Rejoins. Aircraft joining a formation en route will rejoin as briefed to en route position. (T-3) Remain at least 500 feet above or below the formation until the formation is in sight and clearance to rejoin is granted unless briefed otherwise.

17.17.5. En route Procedures.

17.17.5.1. The en route visual formation spacing for all MC-130J aircraft will be 500-6,000 foot fluid trail. (T-3) Tanker Air-to-Air Refueling spacing will be in accordance with ATP-3.3.4.2 guidance. (T-2)

17.17.5.2. At night or in IMC, lead will announce unplanned airspeed changes of greater than 15 knots, unless briefed otherwise. (T-3)



17.17.5.3. Aircraft aborting after assembly will notify lead and turn away from formation. (T-3) The aborted aircraft will either rejoin at the end of the formation or proceed to a suitable recovery field. (T-3) Aircraft within a flight will reposition as briefed. (T-3)

#### 17.17.6. Formation Objective Area Procedures.

17.17.6.1. VMC Airdrop Spacing. MC-130 crews are authorized to conduct all high-speed and 50% flap airdrops in visual formation. Minimum spacing for visual formation airdrop is 2,000 feet (**Exception:** MCADS or CCA-LVADS minimum spacing is 500 feet). Minimum spacing for reduced flap setting drops (e.g., CDS and CRS) is 6,000 feet between aircraft. Waiver authority for reduced airdrop spacing is GP/CC or COMAFSOF.

17.17.6.2. IMC Airdrop Spacing. Minimum spacing for formation IMC airdrops is 6,000 feet.

17.17.6.3. Formation Airdrop Altitude Separation. Subsequent aircraft should select a drop altitude at least 50 feet above the preceding aircraft to avoid wake turbulence.

17.17.7. Landings. For 50% flap minimum interval landings, the desired landing interval is 20 seconds; minimum landing interval is 15 seconds. For 100% flap minimum interval landings, the desired landing interval is 30 seconds, minimum landing interval is 20 seconds. Consider extending these intervals for strong crosswinds, narrow/short runways, or other adverse conditions. For simultaneous landings, planned touchdown point separation will be 3,000 feet minimum using 100 percent flaps. Consider extending the landing interval for excessive wind conditions or wet/slippery runway conditions. A combination of simultaneous and min-interval landings may be planned. Unless otherwise briefed, for other than simultaneous landings, bring throttles into the ground range at 3,000 feet remaining, brakes and reverse at 2,000 feet remaining. For simultaneous landings, followers will slow to a safe taxi speed prior to the preceding aircraft's touchdown point. Minimum spacing between simultaneous landing elements is 90 seconds. Use 30 seconds minimum spacing for a minimum interval element following a simultaneous element. Touch-and-go landings out of formation recoveries are prohibited. Minimum visibility for formation landing is 1 mile (RVR 50).

17.17.8. Dissimilar Formations. MAJCOMs will define dissimilar formation procedures other than refueling procedures listed here. For formation HAAR/TAAR, use geometries, positions and lost contact procedures described in ATP 56C, *Air-to-Air Refueling*. For formation AAR use geometries and positions described in ATP 56C.

17.17.9. Minimum aircraft lateral spacing is 500 feet, but may be further restricted by the approval authority.

17.17.10. Command and Control. Clear lines of command must be established during formation flight. Personnel in the following roles will be identified during mission planning and will be annotated on the flight orders (unless noted otherwise): (T-3)

17.17.10.1. Air Mission Commander (AMC) and Deputy Mission Commander (DMC). For AMC and DMC formation duties see [Paragraph 2.7](#) through [Paragraph 2.8](#).

17.17.10.2. Formation Commander. Required on every formation mission. The designated commander of a formation of aircraft is responsible for successful completion of the formation's portion of the mission and is chosen from the PICs, or CSOs, involved

in the mission. The formation commander works closely with the AMC (if one is utilized) to accomplish the overall mission and is usually designated DMC in missions employing a dedicated AMC.

17.17.10.3. Formation Lead. The lead aircraft in a formation flight is responsible for proper mission execution and other immediate action events during a formation flight.

17.17.11. Dissimilar Formation Briefings. A face-to-face briefing between all involved crew members is highly desired. As a minimum, dissimilar formation briefings must be attended by all PICs and the CSO from each crew. When geographic separation between units precludes a face-to-face briefing, the AMC will coordinate directly with each PIC to ensure each crew receives all appropriate formation and mission information prior to their individual crew briefings. (T-3) At a minimum, brief the following items: communications, Air-to-air TACAN, lighting, power settings, speeds, inadvertent weather penetration airspeeds and procedures, and formation geometry. Inadvertent weather penetration speeds will be agreed upon and briefed prior to flight. (T-3)

17.17.12. Inadvertent Weather Penetration. Upon entering marginal VMC or IMC, the following procedures apply: **WARNING:** Inadvertent weather penetration procedures must be briefed. These procedures are designed for use from visual trail formation during straight and level flight with no more than 3 aircraft. It may be necessary to modify these procedures due to formation geometries, terrain, airspace restrictions, etc. Inadvertent weather penetration in mountainous terrain may be extremely hazardous. Mission planners must devise and brief procedures that best suit the situation. (T-3) **Note:** Inadvertent weather penetration procedures are for emergency use and do not constitute authority to violate AFI 11-202, Vol 3 or Federal Aviation Regulations. Exercising these procedures under actual weather conditions is a violation subject to appropriate action by the AF and FAA. Individual aircraft should maintain VFR if there is sufficient warning to take evasive action. Flight leads will take all practical measures to avoid entering controlled airspace without clearance. (T-3)

17.17.12.1. Wing aircraft immediately initiates a climbing turn as required for its position in the formation and gives "Call Sign" then "IMC Break" three times over the primary interplane radio. The lead aircraft responds with call sign, heading and base altitude. Base altitude will be as follows: MSA, if position is within the MSA corridor; or ESA, if not. (T-3) **Note:** During training and exercise operations, the IMC Break call will be made on a non-secure radio. Lead's response will be made on the same non-secure radio by the CSO (unless briefed otherwise), and the response should be called twice to ensure all wingmen copied the heading and altitude. (T-3)

17.17.12.2. All aircraft turn navigation lights to bright and turn transponder modes 1 and 3 to normal (if the threat environment allows).

17.17.12.3. Lead aircraft uses power as required and climbs straight ahead at a base airspeed of 220 KCAS until reaching base altitude or VMC conditions, whichever occurs first. Upon reaching this altitude, maintain base airspeed of 220 KCAS. If lead is unable to climb at 220 KCAS, the aircraft commander will establish a new base airspeed and inform the formation over interplane frequency. (T-3)

17.17.12.4. The #2 aircraft immediately turns right 10° or more (if feasible), sets power as required and climbs at base airspeed minus 20 KCAS to base altitude plus 500 feet or VMC

conditions, whichever occurs first. After 30 seconds, resume original heading. Upon reaching altitude, accelerate to base airspeed.

17.17.12.5. The #3 aircraft immediately turns left 10° or more (if feasible), sets power as required and climbs at base airspeed minus 40 KCAS to base altitude plus 1,000 feet or VMC conditions, whichever occurs first. After 30 seconds, resume original heading. Upon reaching altitude, accelerate to base airspeed.

17.17.12.6. If VMC conditions are encountered and can be maintained, rejoin the formation visually after obtaining permission from Lead. **WARNING:** The direction of turn for IMC breaks is based on a “no terrain” situation. Terrain, threats, or fluid trail position may dictate a direction of turn different from what your formation position calls for. Situational awareness is critical to terrain and threat avoidance when weather is inadvertently encountered. **Note:** If the altitude to which the formation is climbing is only several hundred feet above en route altitude, a less aggressive climb profile (Vertical Velocity Indicator) may be appropriate. Remember, the climbing turn and speed differential are what get the desired separation and the amount of power set gives you the desired climb away from terrain. **Note:** All IMC maneuvering should be smooth and deliberate with reference to flight instruments to prevent spatial disorientation.

17.17.13. Preplanned Weather Penetration. These procedures enable weather penetration en route to a VMC objective area. They are designed to transition a formation from visual trail to Radar Trail prior to entering weather and permit continued formation flight in IMC. Using these procedures, it is possible to fly an IMC route segment at a preplanned safe altitude while still maintaining formation integrity.

17.17.13.1. On lead’s signal, lead accelerates 20 KCAS, #2 maintains en route airspeed, and #3 reduces speed 20 KCAS. The formation maintains this airspeed differential for 3 minutes, then resumes en route airspeed. This should establish approximately 1 mile separation between aircraft. On the same signal, lead maintains/climbs to base altitude, #2 climbs at 1,000 feet per minute to base altitude plus 500, and #3 climbs at 1,000 feet per minute to base altitude plus 1,000 feet. Base altitude will be as follows: MSA, if position is within the MSA corridor; ESA if outside the corridor, or an appropriate en route altitude if outside the low-level environment. Depending on the environment, altitudes may be amended (i.e., base plus 100 feet, base plus 200 feet or all aircraft at co-altitude). **Note:** Radar Trail requires the lead aircraft to report all off flight plan headings, altitude and airspeed changes on interplane radio when operating in a permissive environment or requires these changes be thoroughly preplanned and flown precisely when operating in a hostile, comm-out environment.

17.17.14. Assembly. The formation commander will brief how rejoins and position changes are to be accomplished in the VFR pattern. (T-3) If multiple formation recoveries are planned for the VFR pattern, it may be preferable to brief that rejoins in the pattern are directly to trail and for wingmen to call “in” when in position.

17.17.15. Lead Considerations:

17.17.15.1. During visual trail formation, wingmen maintain position strictly by a visual reference to the preceding aircraft. Because of this, it is essential that lead maintain a stable reference platform by flying constant power settings as much as possible. Small climbs

should be made by changing pitch and leaving power set. For climbs in excess of 500 feet, set power and adjust pitch as necessary to avoid obstacles. For descents in excess of 500 feet, set power not less than approximately 600 HP and adjust pitch to maintain the desired airspeed or rate of descent. Under normal circumstances, lead should avoid using flight idle or maximum power settings, since they may outperform the ability of the wing aircraft. Power Lever movement should be smooth and relatively slow to allow adjustments by wingmen. **WARNING:** Pilots must keep in mind the risks of overrunning the lead aircraft. Use all means to notify Lead of an overrun situation in order to avoid a collision.

17.17.15.2. During fluid trail formation, climbs and descents should be made much the same as visual trail. Small climbs should be made by changing pitch and leaving power set. For climbs in excess of 500 feet, set power and adjust pitch as necessary to avoid obstacles. Lead should use climb power minus one knob width to give wing aircraft a power advantage. For descents in excess of 500 feet, set power not less than approximately 1,000 HP (1.5 knob) and adjust pitch to maintain the desired airspeed or rate of descent. Like visual trail, lead should be smooth with power changes; however, a greater range of high and low settings are available due to the spacing of the aircraft. The formation commander may brief alternate rates and power settings for fluid trail climbs and descents.

#### 17.17.16. Aircraft Lighting:

17.17.16.1. Departure and Recovery. Normal or reduced lighting is authorized IAW AFI 11-202, Vol 3.

17.17.16.2. En route. In the ATC environment, during other than actual combat operations, all aircraft not in a standard formation (standard formation is defined as less than 1 mile horizontal separation and less than 100 feet vertical, IAW FAA) will be fully lighted as required by AFI 11-202, Vol 3. (T-2)

17.17.16.3. Night Vision Goggles (NVGs). Refer to **Table 17.4** for exterior and interior light settings when using NVGs. The signal to transition to/from NVG lighting will be as briefed. (T2) **Note:** When other than standard AFI 11-202, Vol 3, lighting is required due to mission constraints, **Table 17.5** provides a reference for light configurations and light signals to be used during formation and helicopter air refueling operations.

**Table 17.4. Lighting Chart.**

1. Day Formation. All aircraft will have lighting IAW AFI 11-202, Vol 3.
2. Night Formation without NVGs. All aircraft will have lighting IAW AFI 11-202, Vol 3.
3. Echelon Formation, Night, Using NVGs:
a. Master Switch - COVERT, Covert/Formation – as required
b. Navigation Lights – OFF
c. Anti-Collision/Strobe Lights – OFF
d. Pod and Hose Illumination Lights – OFF
e. Leading Edge Lights – OFF
f. UARRSI Lights – OFF

4. Fluid Trail: Same as item 3 except, spacing and illumination may require higher formation light setting.

**Note:** For training and exercise flights (with or without NVGs), the last aircraft in the formation will be lighted IAW AFI 11-202, Vol 3. At night aircraft may turn off the pod and hose illumination, leading edge, and fuselage lights, to aid night vision. During training and exercise flights, all aircraft will have lighting IAW AFI 11-202, Vol 3, when not in fluid trail or echelon formation.

**Note:** Formations may vary lighting as necessary provided they maintain adequate visual identification of the formation.

17.17.17. Any wingman losing radar in IMC, (TCAS is not on or operational) should immediately notify the formation commander and turn away from the formation heading (if not in a safe position) toward permissive terrain. If TCAS is operational, the degraded aircraft may continue in IMC conditions as number two. If VMC, move to a trail position. Loss of systems while en route should be thoroughly covered in the formation briefing.

**17.18. Tanker Air-to-Air Refueling.** Conduct IAW TO 1C-130(M)J-1 and ATP-56(C).

17.18.1. Minimum Altitudes. Select a refueling altitude based on the threat environment. Minimum HAAR/TAAR altitude is 500 feet AGL, without a waiver. Low-altitude HAAR/TAAR training below 1,000 feet AGL will not be conducted at tanker gross weights above 130,000 pounds or without three engine climb capability of at least 500 FPM. (T-2)

**Note:** A minimum vertical separation of 500 feet will be maintained when conducting rendezvous to another C-130 aircraft simulating HAAR/TAAR. (T-3)

17.18.2. HAAR Minimum Separation/Ingress. The receiver join-up altitude will be at least 300 feet below the refueling altitude for all receiver low procedures and at least 200 feet above the refueling altitude for all receiver high procedures. (T-2) Ingress should be at AAR altitude.

17.18.3. TAAR Minimum Separation/Ingress. Prior to positive identification, a minimum vertical separation of 500 feet will be maintained between tanker and receiver during all rendezvous, except a minimum vertical separation of 1,000 feet will be maintained between tanker and receiver during tanker orbit rendezvous procedures. Once the receiver is positively identified, minimum vertical separation may be reduced to 300 feet. Ingress should be at rendezvous altitude.

17.18.4. The MC-130J is authorized to conduct fixed wing air to air refueling (FWAAR) with USN/USMC AV-8B aircraft and USN/USMC F/A-18A/B/C/D/E/F and EA-18G. Follow the procedures in ATP-3.3.4.2 (C) Chapter 2 – Fixed Wing Procedures. For Multi-Tanker Formation operations, crews may utilize either ATP-3.3.4.2 (C) – Annex 2N KC-130 AAR Formation Procedures or ATP 3.3.4.2 (C) US STANDARDS RELATED DOCUMENT (SRD) 3B.13. Echelon Fixed-Wing AAR Formation, whichever is more appropriate for mission tasking.

**17.19. Receiver Air-to-Air Refueling.** Conduct IAW TO 1C-130(M)J-1 and ATP-56(C).

17.19.1. Communication. Unless directed otherwise by a specific exercise operations order/plan, or during contingencies, communication capability between tankers and receivers will be maintained during all normal rendezvous and air refueling operations. (T-3) Voice

transmissions will be IAW the emission control option used. (T-3) **CAUTION:** Air refueling operations will not be conducted when radio communications capability between the tanker and receiver is lost, except during emergency fuel situation. If radio communications are lost, or unreadable between the boom operator and receiver pilot, contacts will not be attempted.

17.19.2. Use manual boom latching procedures only during fuel emergencies and contingency operations. **Exception:** Manual boom latching procedures are authorized for all refueling operations with the KC-10 if the tanker's independent disconnect system is operational.

17.19.3. Altitude Reservations (ALTRV). Whenever practical, refueling operations are done on tracks or anchor areas published in the DoD FLIP. ALTRVs are used when certain missions or operational considerations may require air refueling operations in areas not published in FLIP. For specific ALTRV procedures, refer to FLIP and FAA Special Military Operations 7610.4H, 3.

17.19.4. Special Operations Air-to-Air Refueling Procedures. Refer to AFTTP 3-3.E/MC-130J and AFI 11-2KC-135 Volume 3, Addenda C, *KC-135 Special Operations*, for specific procedures.

## Chapter 18

### LEAFLET AIRDROP

**18.1. General.** Leaflet airdrops are accomplished in both hostile and permissive environments.

**18.2. Mission Description.** Mission requirements vary widely depending on the volume of leaflets airdropped, leaflet packaging, and the altitude of the airdrop. Loads will normally not exceed 25,000 pounds. Drop altitudes may vary from 500 feet AGL to the aircraft service ceiling. Leaflet drops require the movement of boxes of various weights from throughout the cargo compartment via intermediate rollers (if required) to the ramp area for dispersal off the ramp. If specific mission requirements dictate deviation from information contained in this publication, modify procedures to meet specific requirements. Note: All airdrops conducted above FL250 require a waiver to AFI 11-202, Vol 3. Long duration high-altitude drops will require the aircraft remain open. Consider outside air temperature and clothing requirements prior to step.

**18.3. Equipment.** In addition to normal aircraft equipment, the following items may be required to perform leaflet drops:

18.3.1. Parachutes or restraining harnesses must be available for use by all personnel working in the cargo compartment. (T-2)

18.3.2. A portable oxygen console with a minimum of four regulators and output hoses with sufficient length to reach throughout the entire cargo compartment must be available for high-altitude airdrops (as required by AFI 11-409). (T-2)

18.3.3. An interval timer is desirable (alternating red and green jump lights may serve for sequencing the drops or as briefed).

**18.4. Aircraft Configuration.** Determine if leaflets are to be floor loaded or are configured on pallets. Based on how the leaflets are prepared and the volume of leaflets to airdrop, there are several possible configurations.

18.4.1. Palletized Loads. Preload large volumes of leaflets on pallets and load as palletized cargo. Resources permitting, this is the recommended procedure for large volumes of leaflets.

18.4.1.1. Use modified pallets with warehouse rollers attached to the top of the pallets in two sticks.

18.4.1.2. Stack the leaflet boxes on the pallets in two sticks and secure them to the pallets before loading aircraft.

18.4.1.3. In addition to the modified pallets, provide a bridge to span the gap between the last floor pallet and the ramp pallet.

18.4.1.3.1. Construct the bridge so the rollers on it are the same height as the rollers on top of the pallets when loaded in the Enhanced Cargo Handling System (ECHS).

18.4.1.3.2. Install the bridge after the ramp is lowered to the airdrop position and before completion of the Slowdown/Three-minute checklist.

18.4.2. Floor Loads. Leaflets may also be loaded directly on the aircraft intermediate conveyors, if available. Employ this procedure for smaller loads of leaflets or when the equipment mentioned above is not available.

18.4.2.1. Individual boxes have to be hand loaded and each group of boxes individually secured using aircraft tie-down equipment.

18.4.2.2. Configure the aircraft IAW AFMAN 11-2EC/MC-130J, Vol 3, Addenda A.

18.4.2.2.1. Install the HSSLADS rollers if the size of the leaflet boxes permit.

18.4.2.2.2. If the HSSLADS rollers are not available the boxes may not roll or may be damaged if loaded on only one roller conveyor. Consider using CDS skid boards or sheets of plywood as skids under the leaflet boxes.

18.4.2.2.2.1. If using this option, secure each skid of leaflets individually using aircraft tie-down equipment.

18.4.2.2.2.2. Drift each skid back to the ramp hinge during the airdrop, exercising caution not to let the skid board exit the aircraft.

18.4.2.2.2.3. Secure the empty skids against the side wall until the airdrop is completed.

**18.5. Preparation for Loading.** Complete applicable portions of the appropriate TO 1C-130(M)J-9 checklists as follows:

18.5.1. Cargo Loading Preparation.

18.5.2. Cargo Loading (Palletized/Floor Load/Winching Vehicle).

18.5.3. Airplane Preparation for Container Delivery System (CDS) Airdrop.

18.5.4. Anchor Cables. Rig one anchor cable on each side of the aircraft.

18.5.4.1. Attach the aft latch of each anchor cable to the inboard U-bolt on the aft anchor cable support on each side of the airplane.

18.5.4.2. Position the anchor cable stops to the very forward or aft end of the cable, or remove and stow the stops, unless they are used as stops for the restraint harness restraint strap.

18.5.4.3. Attach the forward latch to the center U-bolts on the forward anchor cable support.

18.5.4.3.1. If the center U-bolts are not accessible because of aircraft configuration, attach the forward latch to the outboard U-bolts.

18.5.4.3.2. If connecting the forward latch to the outboard U-bolts, leave additional slack in the cable to allow anchor cable installation in the outboard location on the A-frame during the airdrop.

18.5.4.3.3. Lower the center anchor cable supports and lock them in the vertical position with the tubular supports. Do not connect the anchor cable to the A-frame during rigging. The cable may block the cargo door from properly opening and closing.



18.5.4.3.4. The aft anchor cable support arm micro switches should be isolated so that the cargo ramp will operate with the anchor cables lowered. (T-2) Isolate the aft anchor cable support arm micro switches by pulling ECB 834 (L ANCHOR LINE ARM) and ECB 835 (R ANCHOR LINE ARM).

18.5.5. Static line Retrievers. Suspend oxygen hoses from static line retriever cables for high-altitude missions (as required).

18.5.5.1. Unwind static line retriever cable(s).

18.5.5.2. Install quick disconnects on the aft end of cable(s).

18.5.5.3. Secure the quick disconnects to the inboard side of the A-frame with two turns of 1/4 inch cotton webbing. Make this tie approximately 18 inches above the anchor cable attaching point. If the static line retriever is inadvertently rewound, the tie will break and will prevent damage to the A-frame or static line retriever. (T-2)

18.5.5.4. Remove all slack from static line retriever cables.

18.5.6. Oxygen Hoses and Interphone Cord. Tape or tie extended oxygen hoses and interphone cords together and suspend from static line retriever cables with G-13 clevis or suitable substitute.

18.5.6.1. Ensure that approximately 12 G-13 clevises or suitable substitutes are available to tie oxygen hoses to the static line retriever cable(s).

18.5.6.2. Recommend the kicker use the oxygen regulator and interphone cord aft of the left paratroop door. Route the cord and hose up and over the overhead structural beams, and back down next to the overhead ADS release. This technique keeps the hose and cord off the floor preventing them from becoming tangled or damaged. It also keeps it out of the kicker's way while kicking boxes and retrieving static lines.

**18.6. Securing Boxes. Secure five boxes on the ramp for airdrop. If loading preloaded pallets, two sticks of five boxes each, are secured on the ramp pallet.**

**18.7. Connecting Static Lines. Connect static lines to the anchor cable aft of the A-frame.**

**18.8. Restraint Strapping.** Place a single length of Type III nylon, as final restraint, over the stick of boxes. The cargo restraint strap over the boxes on the ramp is removed at the 1-minute warning. The Type III nylon final restraint is cut at the release point.

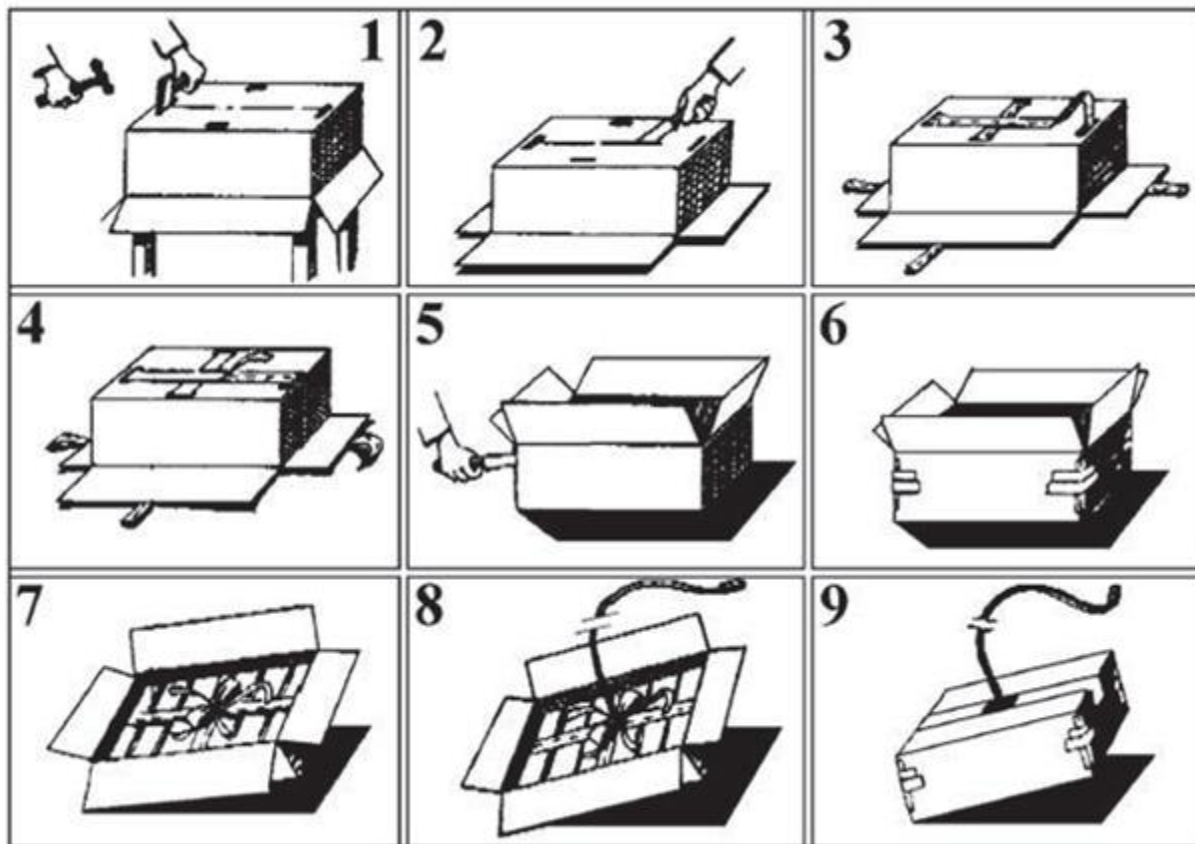
**Figure 18.1. Leaflet Box Rigging Procedures.**

**18.9. Leaflet Box Rigging Procedures.** Rigging boxes for high-altitude static line dissemination.

18.9.1. Using a punch, cut four holes approximately 2 1/2 inches by 3/4 inches as indicated in [Figure 18.1](#). If a punch is not available, a knife can be used. When using a punch, the box must first be placed upon an object slightly deeper and smaller than the box so that a hard-surface is provided when striking the punch.

18.9.2. Cut through the box from one hole to another as illustrated in [Figure 18.1 Leaflet Box Rigging Procedures](#).

18.9.3. Place a 2-inch wide length of webbing through the holes. The length of webbing depends upon the size of the box, but must be long enough to tie after the box has been filled with leaflets. (T-2)

18.9.4. Place a 3- or 4-inch strip of masking tape over the 2-inch wide webbing.

18.9.5. Cut all four corners of the box from the top to about three-fourths of the way down (or less).

18.9.6. Again using masking tape, tape one strip up the cut portion and two across, as illustrated.

18.9.7. After filling the box with leaflets, tie the two strips of webbing.

18.9.8. Attach one end of the static line to the webbing ties. The length of the static line should be a minimum of 15 feet long. The box is rolled out of the aircraft and as the container comes to the end of the static line, the sides of the box split. In effect, it is turned inside out. The leaflets fall away followed by the empty box.

18.9.9. This is one method, and may not be the method suited for your mission. Other variations do exist; however, this is the most universal and least complex.

**18.10. Preparation for Airdrop.** After takeoff, take the following actions before starting the leaflet airdrop checklist.

18.10.1. Cover the cargo door switch with a length of tape to prevent accidental operation of the door with the aft anchor cable support arm down.

18.10.2. Lower anchor cables and connect them to the outboard side of the anchor cable supports.

18.10.3. Isolate the aft anchor cable support arm micro switches by pulling ECB 834 (L ANCHOR LINE ARM) and ECB 835 (R ANCHOR LINE ARM).

18.10.4. Position/don emergency equipment and survival gear.

18.10.5. Begin Leaflet Airdrop checklist.

**18.11. Aircrew Procedures.** Normally leaflet airdrops requires two PTs (for high-altitude airdrops) and three additional crew members to act as feeders. The primary loadmaster will assign specific positions for activity in the cargo compartment. (T-2)

18.11.1. Maneuvering. Base configuration on desired coverage and airframe airspeed limitations. All personnel should be constantly aware of the possibility of an emergency break upon encountering a threat.

18.11.2. Drop Configuration/Flaps. Flaps are normally set at 50% and flap settings should not be changed during the drop unless the loadmaster is notified. **Note:** At very high-altitudes, the aircraft may not be able to maintain drop airspeed with 50% flaps. Under these conditions, use an intermediate flap setting that allows for aircraft performance and also produces an acceptable deck angle for the drop. A flap setting near 20% gives the best aircraft wing performance while providing high rudder boost for controllability.

**18.12. Static Lines.** To increase speed of closing the ramp if a hostile threat is detected and to prevent damage to the aircraft, the static lines should be stowed after each box goes out. Do this if the interval between boxes permits safe operation. Static lines may be cut in an emergency.

## Chapter 19

### SEARCH AND RESCUE PROCEDURES

**19.1. General.** Most searches are part of an effort to save life; therefore, make every effort to complete the search as rapidly and efficiently as possible. A thorough scan of the search area and accurate navigation significantly increase the probability of detection. Reactions to sightings must be timely and accurate. This section outlines operational procedures for conducting effective searches in the C-130 aircraft. Refer to the *International Aeronautical and Maritime Search and Rescue Manual (IAMSAR) Volumes I/II* for additional information. (T-2)

**19.1.1. Search and Rescue Satellite-Aided Tracking (SARSAT).** SARSAT is an international satellite system for Search and Rescue (SAR). It consists of a constellation of seven satellites in low earth orbit, 5 geostationary satellites and a network of earth stations, which provide distress alert and location information to appropriate rescue authorities anywhere in the world for users in distress. The SARSAT satellites detect beacons broadcasting on 406.025 MHz. The current SARSAT system consists of 64 Local User Terminals (LUT) and 26 Mission Control Centers in 32 countries, including 12 in the United States. SARSAT coverage on 406 MHz is worldwide. The Rescue Coordination Center (RCC) at Langley Air Force Base (AFB), VA, maintains a deployable LUT capability (camper sized, air transportable vans) to provide contingency coverage.

**19.1.2. Search and Rescue Frequencies.** Radio frequencies internationally agreed upon for emergency use and search and rescue are identified in [Table 19.1](#) and [Table 19.2](#).

**Table 19.1. Search and Rescue Frequencies.**

Frequency	Usage	Mode <sup>1</sup>	Authority
251.9 MHz	Operational and Training	V	RFA <sup>2</sup>
252.8 MHz	Operational and Training	V	RFA
259.0 MHz	Operational and Training	V	RFA
381.0 MHz	Operational and Training	V	RFA
46.85 MHz	Operational and Training	V	RFA

**Notes:**

1. Modes are V for voice, CW for International Morse Code, and FM for VHF FM.
2. The AF Radio Frequency Allocation (RFA) list is the authority for the use of these

**Table 19.2. Distress and Emergency Frequencies.**

Frequency	Usage	Mode <sup>1</sup>	Authority
2.182 MHz <sup>3</sup>	Aero/Maritime Survival Craft	V	Joint Pub 3-50.1 <sup>2</sup>
2.670 MHz	USCG Emergency Coordination	V	
3.0235 MHz	International Scene of Action SAR	V	Joint Pub 3-50.1

4.835 MHz	AF Crash Boats (General)	V, CW	
5.680 MHz	Int'l Scene of Action SAR	V	Joint Pub 3-50.1
5.717 MHz	Canadian MAMSS SAR	C	Canadian IFR Sup
8.364 MHz	For use internationally by Survival Craft Stations	CW	Joint Pub 3-50.1
121.5 MHz	Int'l Aeronautical Emergency	V	Joint Pub 3-50.1
123.1 MHz	NATO/ICAO Scene of Action	V	Joint Pub 3-50.1
138.45 MHz	ARRS Scene of Action	V	
138.78 MHz	Scene of Action	V	
156.8 MHz	Maritime Mobile VHF Radio-Telephone Service As A Distress, Safety, and Calling (Channel 16)	FM	Joint Pub 3-50.1
243.0 MHz	Int'l Aeronautical Emergency	V	Joint Pub 3-50.1
282.8 MHz	Int'l Scene of Action SAR	V	Joint Pub 3-50.1

**Notes:**

1. Modes are V for voice, CW for International Morse Code, and FM for VHF FM.
2. Joint Publication (JP) 3-50, *Personnel Recovery* explain the use of these frequencies, which are authorized in the RFA of the International Telecommunications Union (ITU) Radio Registration (see following note).
3. In order to be on the correct frequency, ensure HF equipment is set to AM, not Upper Side Band (USB).

**19.2. Search Altitude.** Use [Figure 19.1](#) and [Table 19.3](#) through [Table 19.6](#) to select a search pattern and [Table 19.7](#) to select an optimum search altitude based upon the object of search, weather in the search area, electronic or visual location aids used, and any other known factor, which would affect the search altitude. Generally, the lower the search altitude, the better the chance of seeing an object, provided the altitude is not so low that the aircraft speed becomes detrimental. During preliminary searches, the altitude will be higher to detect possible signals at greater distances. (T-2)

Figure 19.1. Lost Airplane Fixing Procedures.

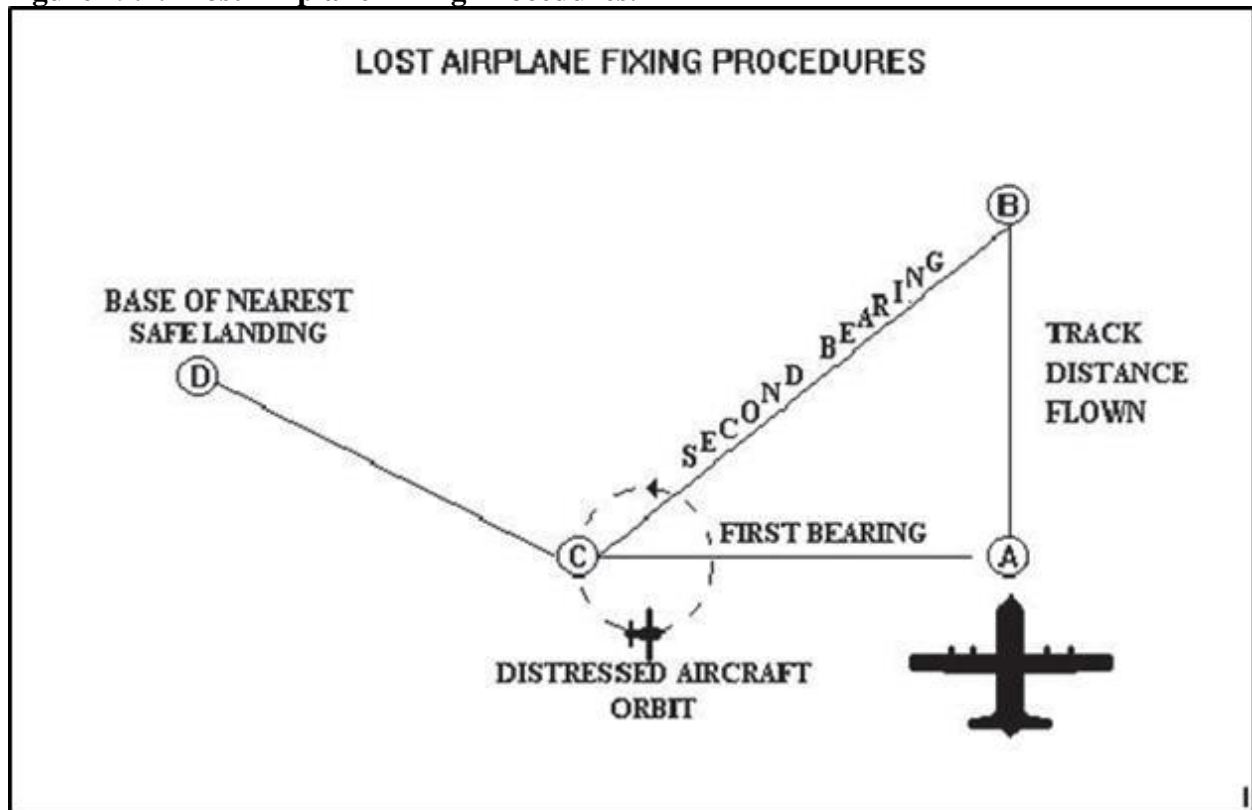

Table 19.3. Sweep Width for Visual Search in Nautical Miles.

Search Altitude X100	Life Rafts				Small Boats (Less Than 30 Feet)					Small Boats (30 To 60 Feet)				
	0	5	10	20	0	5	10	20	30	0	5	10	20	30
1 NM VIS	0.5	0.5	0.5	--	0.5	0.5	0.5	--	--	0.5	0.5	0.5	--	--
3 NM VIS	1.0	1.2	1.2	1.0	2.5	2.4	2.3	1.8	0.4	3.5	3.0	2.7	1.8	0.4
5 NM VIS	1.4	1.6	1.6	2.7	2.7	2.7	2.7	3.2	3.3	4.2	4.2	4.2	4.2	3.3
10 NM VIS	1.8	1.8	2.1	3.6	3.9	4.0	4.2	4.5	5.8	6.5	6.2	6.2	6.2	6.5
15 NM VIS	1.9	1.9	2.6	3.6	5.2	5.3	5.5	6.7	7.0	8.5	8.5	8.4	8.4	8.3
20 NM VIS	2.0	2.1	2.8	3.6	5.3	5.6	6.2	6.8	7.1	8.6	8.8	9.0	9.1	8.9
30 NM VIS	2.2	2.3	2.9	3.6	5.5	6.2	7.0	7.0	7.1	8.7	9.5	10.4	10.1	9.7

Table 19.4. Whitecap Correction Factors.

Wind (Knots)	0	10	15	20	25	30	40
Rafts	0.8	1.0	0.9	0.7	0.5	0.2	0.1
Small Boats	0.9	1.0	1.1	1.0	0.9	0.7	0.2

Dye Marker	0.9	1.0	1.0	0.9	0.6	0.4	0.2
Smoke	0.8	1.0	0.8	0.6	0.4	0.2	0.1

**Table 19.5. Cloud Cover Factor.**

Percent Cloud Cover	0	10	20	30	40	50	60	70	80	90	100
Cloud Cover Factor	1.1	1.1	1.1	1.0	1.0	1.0	1.0	0.9	0.9	0.8	0.7

**Table 19.6. Expected Detection Range for Visual Aids (30 Miles Visibility).**

Daytime		Night Time	
Dye Marker	4 Miles (Reduced to nil in heavy seas)	Float Light	20 Miles
Mirror	8 Miles	Mk 13 Flare	23 Miles
Orange Smoke	12 Miles (greatly reduced in high winds)	Very Light	24 Miles
White Smoke	16 Miles (greatly reduced in high winds)		

**Table 19.7. Recommended Search Altitudes.**

Recommended Altitudes Overwater	Expected Target
500 feet and below	Survivor without raft or dye marker.
500 feet to 1,000 feet	Survivor in raft without dye marker or signaling device
1,000 feet to 2,500 feet	Survivor has dye marker.
1,000 feet to 3,000 feet	Survivor has signaling device or radar reflector.
2,000 feet to 3,000 feet	Expecting to find wreckage during initial phase of the mission.
2,000 feet	During night overwater.
Recommended Altitudes Over Land	
1,000 feet	Survivors of an aircraft incident over level terrain with little foliage.
500 feet	Survivors of an aircraft incident over level terrain with heavy foliage.
500 feet to 1,000 feet	Survivors of an incident in mountainous terrain.
2,000 feet	Expecting to find wreckage.
2,000 feet	Over land at night.

Recommended Altitude For Electronic Beacons
8,000 feet or higher

### 19.3. Search Procedures.

19.3.1. Rescue missions often involve commitment based upon calculated risks. Give full consideration to all safety factors. Timely reaction to all search missions is essential to the safety of personnel or equipment. Do not jeopardize safety by inadequate preparation or short cuts to expedite takeoff, or arrival at search areas. (T-2) For search missions use the Search Checklist. Aircrews will comply with all other applicable directives, which govern their duties, such as:

19.3.1.1. Accomplish complete pre-departure flight planning except for scramble missions. On scramble missions, complete essential flight planning prior to and shortly after takeoff. (T-2)

19.3.1.2. Use in-flight procedures in accordance with the appropriate theater of operation flight regulations. (T-2)

19.3.1.2.1. Aircraft will maintain vertical and horizontal separation in the search area. This is critical when several aircraft are searching within close proximity. (T-2)

19.3.1.2.2. Transmit operation normal (position) reports as required by the controlling agency.

19.3.2. The following general instructions apply to all search missions:

19.3.2.1. Brief crew members that did not attend the operations briefing on the purpose of the mission.

19.3.2.2. Scanners who are not aircrew members will receive a briefing on the search objective. (T-2)

19.3.2.3. The PIC will supervise and coordinate activities of crew members during preparation for search, as follows: (T-2)

19.3.2.3.1. Plan the search.

19.3.2.3.2. Discuss scanning procedures.

19.3.2.3.3. Discuss the procedures for making search pattern turns.

19.3.2.3.4. Discuss the radio communication procedures with the CSO and copilot.

19.3.2.3.5. Discuss the preparation of flares, sea dyes, and smoke signals for deployment with the loadmaster.

19.3.2.3.6. Discuss the preparation of personnel and equipment for airborne delivery with the loadmaster and pararescuemen. Ensure all crew members are thoroughly familiar with the checklists to be used for various airborne delivery options.

19.3.2.4. The PIC will coordinate crew member activities during prosecution of the search by: (T-2)



- 19.3.2.4.1. Ensuring completion of the Search Checklist prior to commencing any low-level search.
  - 19.3.2.4.2. Alerting the scanners to begin scanning when approaching the search area.
  - 19.3.2.4.3. Directing crew members to put on their LPUs prior to descending below 2,000 feet overwater.
  - 19.3.2.4.4. Checking with crew members to ensure all equipment and personnel are ready for action in the event of a sighting.
  - 19.3.2.4.5. Making periodic checks of fuel remaining to ensure sufficient fuel remains for return to home station.
  - 19.3.2.5. Report all deviations from assigned search procedures to the on-scene commander or mission commander.
  - 19.3.2.6. Thoroughly investigate sightings and report findings immediately. Initiate recovery action or assistance when the survivors are located and inform appropriate agencies of the progress.
  - 19.3.2.7. The CSO will: (T-2)
    - 19.3.2.7.1. Maintain an accurate record of area searched.
    - 19.3.2.7.2. Direct the aircraft to ensure proper coverage of the search area.
    - 19.3.2.7.3. Continually cross-check headings, drift, time, airspeed and altitude to maintain the best possible search coverage.
    - 19.3.2.7.4. Use a large-scale chart when searching over land to ensure terrain and obstacle clearance. Use a search pattern graph as a suitable reference while searching overwater.
    - 19.3.2.7.5. Record sighting information on log and plot position on navigation chart.
    - 19.3.2.7.6. Monitor equipment during radar and electronic searches.
    - 19.3.2.7.7. Debrief controlling agency with an accurate depiction of any areas searched.
    - 19.3.2.7.8. When other aircraft are involved, track and assign search areas for other aircraft.
  - 19.3.2.8. The PIC will insure radio communications are maintained with other search aircraft and the controlling agency. (T-2)
  - 19.3.2.9. The loadmaster will assume supervision of the scanners and will schedule rotation and rest periods. Scanners should be rotated every 30 to 45 minutes of scanning and rested after two hours, if enough scanners are available. (T-2)
  - 19.3.2.10. All crew members will assist with the scanning duties when possible. (T-2)
  - 19.3.2.11. When a search is completed with negative results, consider searching the area again. Normally, position subsequent search legs between or 45° to the previous search legs. This procedure, in effect, results in smaller track spacing.
- 19.3.3. In the search area:

19.3.3.1. Descend to search altitude ([Table 19.7](#)).

19.3.3.2. Have CSO obtain the wind at search altitude. To visually cover the area thoroughly, slow the airspeed during search patterns (refer to the Performance Manual).

19.3.3.3. Notify ATC of arrival on scene and estimated endurance.

19.3.3.4. Vector other aircraft to the scene.

19.3.3.5. Use radar (some life rafts carry reflectors).

19.3.3.6. Assume on-scene command until relieved by another duly appointed SAR aircraft. As other aircraft arrive, do the following:

19.3.3.6.1. Establish contact on channels other than Guard.

19.3.3.6.2. Obtain aircraft type identification, endurance, and rescue capability.

19.3.3.6.3. Assign altimeter settings, frequencies, search areas, patterns and altitude separation.

19.3.3.7. If leaving the search area because of lack of fuel, assign another aircraft as on-scene commander.

19.3.4. Determine an accurate wind prior to and throughout the search. Use [Table 19.9](#) to estimate wind velocity near the surface.

19.3.5. When flying search patterns, turns must be accurate and uniform as possible. The following procedures are provided to assist the aircrew in making precise turns:

19.3.5.1. Fly the aircraft on autopilot when possible.

19.3.5.2. Prior to starting the pattern, the CSO will brief the crew on the direction and rate of turn and the turn command procedure used.

19.3.5.3. Normally, all turns are standard rate ( $3^\circ$  per second) unless track spacing is less in distance than the diameter of a standard turn at a given speed. In this situation, continue turn to  $180^\circ$  and adjust turn rate as required to remain within the pattern.

**Table 19.8. Sector Search Pattern Computation.**

		Track Spacing							
S E A R C H  R A D I U S		1-0/t/T	2-0/t/T	3-0/t/T	4-0/t/T	6-0/t/T	8-0/t/T	10-0/t/T	15-0/t/T
	5	6/21/1.6	12/23/0.8	18/25/0.6	25/27/0.5				
	10	3/20/5.4	6/21/3.0	9/22/2.0	12/23/1.6	18/25/1.2	25/27/0.8		
	15	2/20/12.0	4/20/6.2	6/21/4.6	8/22/3.6	12/23/2.6	15/24/2.0	20/26/1.6	
	20	1.5/19/21	3/20/11.2	4.5/21/7.6	6/21/5.8	9/22/4.2	12/23/3.4	15/24/2.8	24/27/1.8
	25		2.5/20/16.2	3.5/20/11.0	5/21/8/6	7.5/21/6.0	9.5/22/5.0	12/23/4.0	18/25/2.8
	30			3/20/16.6	4/20/11.8	6/21/8.8	8/22/6.8	10/22/5.8	15/24/4.0
	40				3/20/22.0	4.5/21/15.2	6/21/11.8	7.5/21/9.8	11/23/7.4
	<p>0 = Degrees to add to 90°</p> <p>t = First turn correction (deduct 11 seconds for successive turns)</p> <p>T = Total time to complete search</p>								

**Table 19.9. Wind and Sea Prediction Chart.**

Wind Velocity In Knots	Height Of Waves In Feet	Beaufort Number	Sea Indications
Calm	0	0	Like a mirror.
1-3	1/2	1	Ripples with the appearance of scales.
4-6	1	2	Small wavelets, crests have glassy appearance.
7-10	2	3	Large wavelets, crests begin to break: scattered whitecaps.
11-16	5	4	Small waves, becoming longer. Fairly frequent white caps.
17-21	10	5	Moderate waves, taking a pronounced long form; many whitecaps.
22-27	15	6	Large waves begin to form; white foam crests more extensive; some spray.
28-33	20	7	Sea heaps up, white foam from breaking waves blown in streaks along direction of waves.
34-40	25	8	Moderately high waves of greater length; crests break into spindrift; foam blown in well-marked streaks in direction of wind.
41-47	30	9	High waves, dense streaks of foam; sea begins to roll; spray affects visibility.

48-55	35	10	Very high waves with overhanging crests; foam in great patches blown in dense white streaks. Whole surface of sea takes on a white appearance. Visibility affected.
-------	----	----	---

19.3.5.4. Drop available emergency equipment and/or personnel, if required. If survivors are in life jackets, make attempts as soon as possible to furnish them with life rafts or other survival equipment and signaling devices.

19.3.5.5. Direct potential rescue or recovery vessels and other aircraft to the scene by radio or visual signals. Radio and visual signals you may use to direct a vessel to the scene to include:

19.3.5.6. Radio message to the vessel.

19.3.5.6.1. ADF to take bearings on a vessel's Low Frequency or Medium Frequency transmissions.

19.3.5.6.2. VHF or UHF direction finder to take bearings of VHF or UHF transmissions.

19.3.5.6.3. Radar and IFF.

19.3.5.6.4. Signal light.

19.3.5.6.5. Dropping message containers.

19.3.5.6.6. Pyrotechnic flares.

19.3.5.6.7. When radio communications are not possible, establish self-identification, then indicate location of the target by:

19.3.5.6.7.1. Circling the vessel at least once at low-altitude.

19.3.5.6.7.2. Flying across the bow of the vessel at least once, and rocking wings at the same time.

19.3.5.6.7.3. Sending a message by signal light or dropping a message, if possible.

19.3.5.6.7.4. Heading in the direction of the target. Repeat this procedure until the vessel acknowledges by following the aircraft, or indicates that it is unable to comply by hoisting the International Flag, November (the International Flag, November, is a blue and white checkerboard). Crossing the wake of the vessel close astern at a low-altitude means that the service of the vessel to which the signal is directed is no longer required.

19.3.5.7. In daytime, use any of the following means to inform survivors they have been sighted:

19.3.5.7.1. Fly low over survivors with landing lights on.

19.3.5.7.2. Blink a signal light in the direction of survivors.

19.3.5.7.3. Drop two marker signals a few seconds apart.

19.3.5.8. Aircrews sighting survivors at night should:

19.3.5.8.1. Mark the position by dropping marker smoke or strobe lights with flotation collars.

19.3.5.8.2. Request assistance from other search aircraft or ships.

19.3.5.8.2.1. If a rescue vessel arrives in the area, direct it to the scene by giving the target position in relation to the float light. Drop parachute flares to assist the rescue or recovery vessel in sighting the target.

19.3.5.8.2.2. If the objective has not been located, but its position is fairly well established, drop two strobe lights or datum marker buoys to outline the limits of the search area, the most probable position of target being halfway between the lights. Start the search from one light to the other, dropping parachute flares for illumination.

19.3.5.8.2.3. If no surface vessel is available, but two aircraft are on-scene, have one aircraft fly over the area at 3,000 feet dropping flares at 2- or 3-mile intervals. Station the other aircraft 3 miles behind the illuminating aircraft, slightly upwind at 500 feet to search.

#### **19.4. Departing Search Area.**

19.4.1. Notify ATC and the appropriate SAR agency on-scene, SAR aircraft, Rescue Coordination Center, etc.

19.4.2. If other search aircraft have not arrived, reconfirm position, and advise survivors when further assistance will arrive, if known. (T-2)

**19.5. Rescue Airdrops.** Rescue airdrops of rescue equipment allow rapid deployment of Sea Rescue Kits, pyrotechnics, emergency equipment, etc., in an unplanned and rapidly changing environment. An example would be dropping a Sea Rescue Kit to a helicopter that ditched during helicopter air refueling. Specific patterns are Sea Rescue Kit deployments and Parabundle and Freefall equipment drops.

19.5.1. The pilot will always brief the pattern and delivery to be flown. (T-2)

19.5.1.1. As a minimum, brief the type of equipment to be delivered, delivery method (pattern shape, relationship to wind, etc.), altitudes, airspeeds, commands to be used, and required actions for malfunctions.

19.5.2. Sea Rescue Kit Deployment. The Sea Rescue Kit is designed to meet conditions, which require aerial delivery of emergency flotation and survival gear. The kit is dropped free-fall and abeam during a crosswind pass over the target. When correctly dropped, a straight line is formed on the water with an inflated raft at each end. After delivery, the two rafts with their high freeboard will begin to drift downwind until retarded by the partially submerged supply containers. Thus, when the kit is properly deployed, wind conditions will cause the kit to form a "U," partially encircling the target. (T-2)

19.5.2.1. Surface wind will affect the kit and target in varying amounts in proportion to the area exposed above the water and displacement below the water. The kit will drift faster than nearly all-seagoing vessels (outboards, cabin cruisers, trawlers, heavy displacement deep draft vessels and 1 man life rafts) but slower than a 6-, 7- or 20-man raft. If a kit drifts faster, it will be delivered upwind. If the target drifts faster, the kit will

be delivered downwind. When the surface wind is less than 15 knots, the delivery pass will be offset approximately 50 feet. Distance will be increased 25 feet for each 10 knots in excess of the 15-knot base. (T-2) **Exception:** Downwind kit drops will always be offset approximately 50 feet. Do not correct for wind. (T-2)

19.5.2.2. When deploying a Sea Rescue Kit in high winds, the kit may be deployed with the rafts deflated to improve drop accuracy.

19.5.2.3. Pyrotechnics may be useful in determining wind strength and direction, and maintaining pattern orientation.

19.5.2.4. Standard Sea Rescue Kit Pattern Procedures (Figure 19.2).

19.5.2.4.1. Maneuver the aircraft onto a flight path that is crosswind and approximately 50 feet from the target on the side opposite to that of the intended kit delivery. Maintain drop altitude and airspeed.

Figure 19.2. Standard Sea Rescue Kit Pattern.

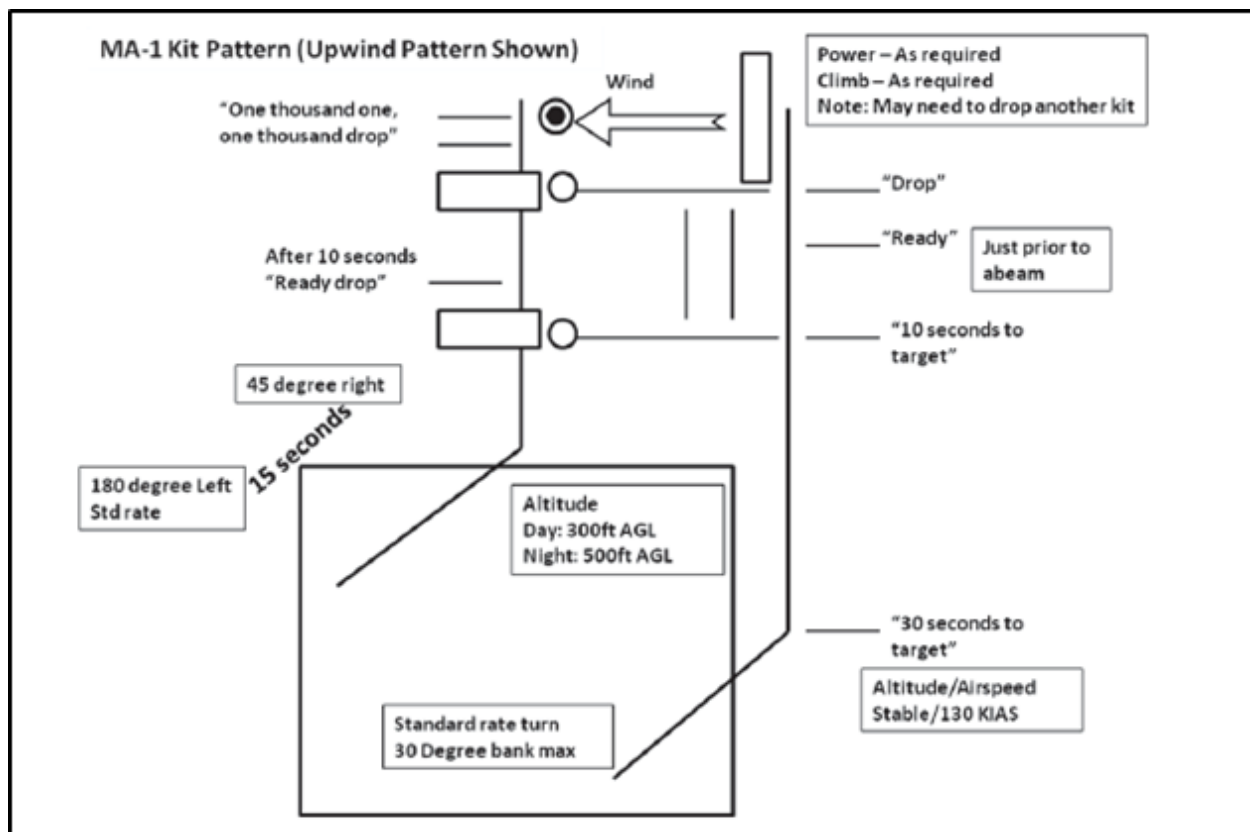

19.5.2.4.2. When abeam the target, begin the count (use seconds). Two seconds past the target, release a smoke marker (if available). The PF will count over interphone, "One thousand one, one thousand drop." On the command of "drop," the loadmaster will manually launch a smoke marker. (T-2)

19.5.2.4.3. Maintain heading for 10 seconds and drop second timing signal (if available). Turn 45° to the right and hold that heading for 15 seconds. Make a 180° left-hand standard rate turn. Adjust turn to final so as to pass upwind or downwind of

the target (as required for the delivery). Distance will vary with the type of target and wind velocity. Rolling out, the pilot will notify the crew: "30 seconds to target." (T-2)

19.5.2.4.4. Approximately 10 seconds from the smoke marker, the pilot will notify crew: "10 seconds." Just prior to abeam the smoke marker, the PF will command "Ready," and then abeam the marker, "Drop." (T-2) **Note:** Aircraft without marker signals should fly the pattern as described and attempt to drop the kit 4 seconds prior to the target.

19.5.2.5. CSO Assistance for Sea Rescue Kits. The CSO can assist the pilot by the use of onboard systems. The CSO will advise the pilot when the aircraft approaches the final delivery track. (T-2)

19.5.2.5.1. The CSO should set up the CNI-MU as follows:

19.5.2.5.1.1. During the flight plan programming portion of the preflight, the CSO should load two dummy waypoints that will later serve as the IP and target. (The target will be the location of the survivor or position to which the kit will be delivered.). (T-3) **Note:** This step will save time in-flight by eliminating the need to modify the flight plan sequence.

19.5.2.5.1.2. As the aircraft flies over the target on the initial pass, the CSO will mark this position and store it. The wind (e.g., 180/015) should be noted and recorded at this time. The onboard system will allow the CSO to direct the pilot perpendicular to the wind on the final run-in to the target.

19.5.2.5.1.3. Go to the plan page. Call up the dummy waypoint that was initially designated the target and redesignate it as the mark point (stored target position). Verify this waypoint.

19.5.2.5.1.4. Go to the preceding waypoint and redesignate it as the mark point.

19.5.2.5.1.5. Define an Initial Point (IP) using a range and bearing from the original mark point and save it as the waypoint prior to the target. Use a bearing that is the reciprocal of the desired run-in heading (e.g., 090/270°) and a range of 5 to 10 NM and verify. The pilot must confirm the final run-in heading before the CSO can load the bearing. (T-3) **Note:** Keep in mind that the target will drift. This is basically a visual maneuver; the nav systems are used as a backup. The pilot should make every attempt to keep the target in sight.

19.5.2.5.1.6. The pilot will use the system to help maintain situational awareness and line up on the target for the delivery pass. During the run-in, the pilot will offset upwind or downwind as necessary. (T-2)

19.5.3. Parabundle and Freefall Deployment:

19.5.3.1. When practical, use a racetrack pattern with the drop heading into the wind for equipment drops; however, circumstances may dictate a modified pattern. Equipment may be dropped from the paratroop doors or the aft cargo door and ramp. The first bundle dropped is, in effect, a spotter bundle; therefore, it should be the least critical to the survivors. Water deliveries must consider wind, drift and sea state. **WARNING:** The

delivery of equipment, no matter how vital, must never endanger the lives of the receivers. (T-2)

19.5.3.2. Equipment deliveries to land drop zones should be planned to impact within 50 yards of the target. Water deliveries should be planned to impact within 5 yards of the target or within a 45° sector centered on the drift line for 100 yards. In any case, deliveries should never be in excess of 5 yards up-drift of the target.

19.5.3.3. Pilot Procedures. Pilots are responsible for determining the mode of deployment; drop location, and type pattern to be flown. They must ensure the loadmaster is aware of the desired point of impact (PI). When the situation permits, the pilot will make an observation pass over the drop zone. Final freefall altitude will be no lower than 150 feet AGL. (T-2) Final parabundle altitude should be no lower than 300 feet AGL. Minimum altitude for all night airdrops is 500 feet AGL. (T-3) **WARNING:** Keep turns below 300 feet AGL to a minimum.

19.5.3.3.1. Aircraft altitude, attitude, course and airspeed should be established by 30 seconds to target and no later than 10 seconds to target. The pilot will keep the crew apprised of their position in the pattern. (T-2) As a minimum, on final the pilot will state "30 seconds to target," then "10 seconds." Once the loadmaster spots the target, he will state, "Target in sight" and provide the pilot with course corrections if time permits. (T-2)

19.5.3.4. Loadmaster Procedures. Loadmasters must understand the location of the desired PI. (T-2) When looking for the target, the loadmaster will use either paratroop door. (T-2) If the PI is difficult to spot, ask the pilot to give a countdown to the PI on the run in.

19.5.3.4.1. The loadmaster will hook up the restraint harness as described in [Paragraph 5.21.6](#). (T-2)

19.5.3.4.2. The jump platform will be extended and the air deflector doors opened. (T-2) The loadmaster may align the aircraft for the airdrop by sighting down the edge of the jump platform to the drop zone and steering the aircraft with standard calls of "Steady," "Right, (number of) degrees," or "Left, (number of) degrees." (T-2) **Note:** If the loadmaster places their head on the jump platform to sight and align the aircraft, they should place their head toward the forward edge for parabundle airdrops, and move their head aft for freefall airdrops and to compensate for higher altitudes.

19.5.3.4.3. Bundle dimensions for paratroop door drops, including the parachute, must not exceed 48 by 30 by 66 inches. (T-2) Bundles in excess of 100 pounds require a second pusher and those between 350-500 pounds require two additional pushers. For equipment to be delivered from the paratroop door, attach the static line (if used) to tie-down ring 26-B or 26-F. Secure equipment until it is ready for delivery.

19.5.3.4.4. If equipment cannot be delivered from the paratroop door, the loadmaster may prepare and position the equipment on the ramp for delivery, and use another thoroughly briefed crew member to release the equipment. The equipment will be secured until ready for delivery. (T-2) For equipment to be delivered from the ramp, attach the static line (if used) to a tie-down ring in row 30. (T-2)



19.5.3.4.5. The loadmaster will normally spot the target 8 seconds prior to the release point, and give the preparatory command "Ready" and the deployment command of "Drop." After each delivery, the loadmaster will report status of drop (load clear or status) and impact point whenever possible. (T-3)

19.5.3.5. Equipment Delivery in Forested Areas. Due to the possibility of equipment hang-up in trees, consideration should be given to attaching drop lines to equipment intended to be delivered by parachute. The drop line needs to be long enough to allow the chute to hang-up in treetops, and still permit ground forces to recover the equipment. (T-2) In addition to the drop lines now in use by units (local design and manufacture), consider the possibility of using equipment already maintained on the aircraft, such as Sea Rescue Kit buoyant rope (210 feet long). Drop lines will be secured to the parachute riser snaps/connectors and equipment package "D/V rings" with carabineers or equivalent. The drop line will be assembled into accordion "S" folds, secured with retainer bands and attached to the equipment package. (T-2) **Note:** Final approach altitude should be adjusted to compensate for tree height, but never less than 150 feet above the treetops.

19.5.3.6. Pattern for Night Aerial Delivery. NVGs may be used for night operations. Aircrews will accomplish the Combat Entry checklist to configure the aircraft for NVG operations. (T-2)

19.5.3.7. Night Delivery. Equipment to be delivered at night will have marker lights attached. (T-3) For water drops, attach the light by securing a double 5-foot length of type III nylon (550/cord) to the marker light, then attach the other end to the equipment. Stabilize the light to the equipment with type number 5 cord. Pass the parachute static line under the type number 5 cord to ensure light breakaway when deployed. For land drops, chemlites are recommended. Attach chemlites securely to prevent detachment.

## 19.6. Sea Rescue Kits:

19.6.1. The Sea Rescue Kit consists of five bundles:

19.6.1.1. The two end bundles (1 and 5) contain either a six, seven or 20 man raft. Bundles 2 and 4 contain emergency radios and bundle 3 contains medical gear.

19.6.1.2. The total weight of all five bundles is 232 lbs for a MA-1 kit and 311 lbs for a MA-2 kit.

19.6.1.3. Each bundle is connected by 210 feet of buoyant rope.

19.6.1.4. The kit is deployed manually off the cargo ramp.

19.6.2. Rigging Sequence.

19.6.2.1. Rigging sequence will be as shown in [Figure 19.3](#). (T-2)

19.6.2.2. During in-flight rigging, the cargo ramp and door will remain closed. Attach a tie-down strap across the kit to prevent movement. (T-2)

19.6.2.3. Unsnap the inflation lanyard protection flap of container #1 (raft), marked 1 of 5 and leave open. Remove enough lanyard from the retaining loops to allow the snap fastener (yellow) to be fastened to ramp tie-down fitting 30F.

19.6.2.4. Remove enough buoyant rope from container #1 to allow the rope fastener (red) to be connected to the D-ring (red) of container #2, marked 2 of 5.

19.6.2.5. Remove enough buoyant rope from container #2 to allow the rope fastener (green) to be connected to the D-ring (green) of the container #3, marked 3 of 5.

19.6.2.6. Remove enough buoyant rope from container #3 to allow the snap fastener (blue) to be connected to the D-ring (blue) of container #4, marked 4 of 5.

19.6.2.7. Remove enough buoyant rope from container #4 to allow the rope snap fastener (white) to be connected to the lanyard loop of container #5, marked 5 of 5.

19.6.2.8. Unsnap the inflation lanyard protector flap on container #5 and leave open. Remove enough lanyard from the retaining loops to allow the snap fastener (yellow) to be fastened to the ramp tie-down ring 30B. **Note:** In high winds, the kit may be deployed with the rafts deflated to improve drop accuracy. If this procedure is necessary, the life raft inflation lanyard should be shortened and red streamers attached with the words "PULL TO INFLATE" on the streamers to facilitate inflation by the survivors.

#### 19.6.3. Rigging of Lights on Sea Rescue Kits for Night Airdrops:

19.6.3.1. Lights are attached to containers 1, 3, and 5 (Refer to **Figure 19.4** for procedures). The loadmaster will inspect the lights for proper function prior to installation. (T-2)

#### 19.6.4. Airdropping a Sea Rescue Kit in Support of SAR:

19.6.4.1. Aircrews will use the Search Checklist. (T-2)

19.6.4.2. The loadmaster will deploy the kit manually when the pilot states "Drop." (T-2) **Note:** When delivering the Sea Rescue Kit manually, the loadmaster will deliver all kits starting with the number 1 container. The desired interval is .7 seconds between the containers, and all five containers must be delivered within 3.3 seconds to prevent line breakage and/or damage to the kit . (T-2)

19.6.4.3. Any delay by the loadmaster after the pilot states "Drop" might cause the kit to land long.

19.6.4.4. The loadmaster will use a restraint harness with the lifeline attached to a tie-down ring no further aft than FS 737, or anchor cable with an anchor cable stop positioned at FS 737. (T-2) The restraint harness lifeline will be adjusted to allow movement to FS 835. (T-2) **Note:** The loadmaster will ensure all checklist items are completed, maintain control of bundles, monitor, and rerig any loose straps/static lines or equipment that may come undone due to wind blast. (T-2)

Figure 19.3. Rigging Sequence.

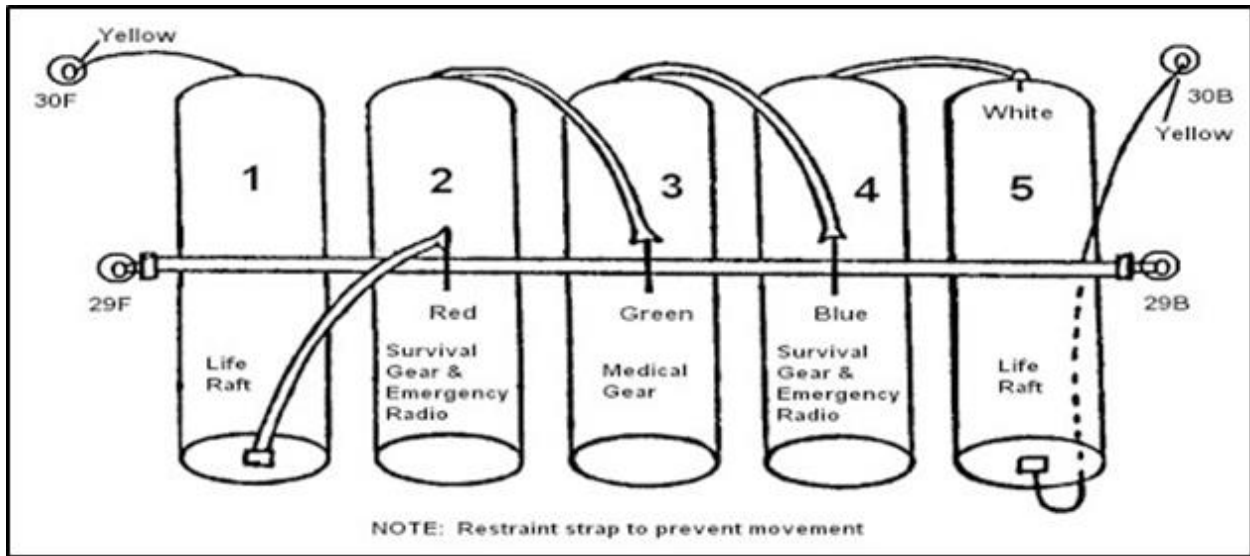

**Figure 19.4. Sea Rescue Kit, Light Rigging.**

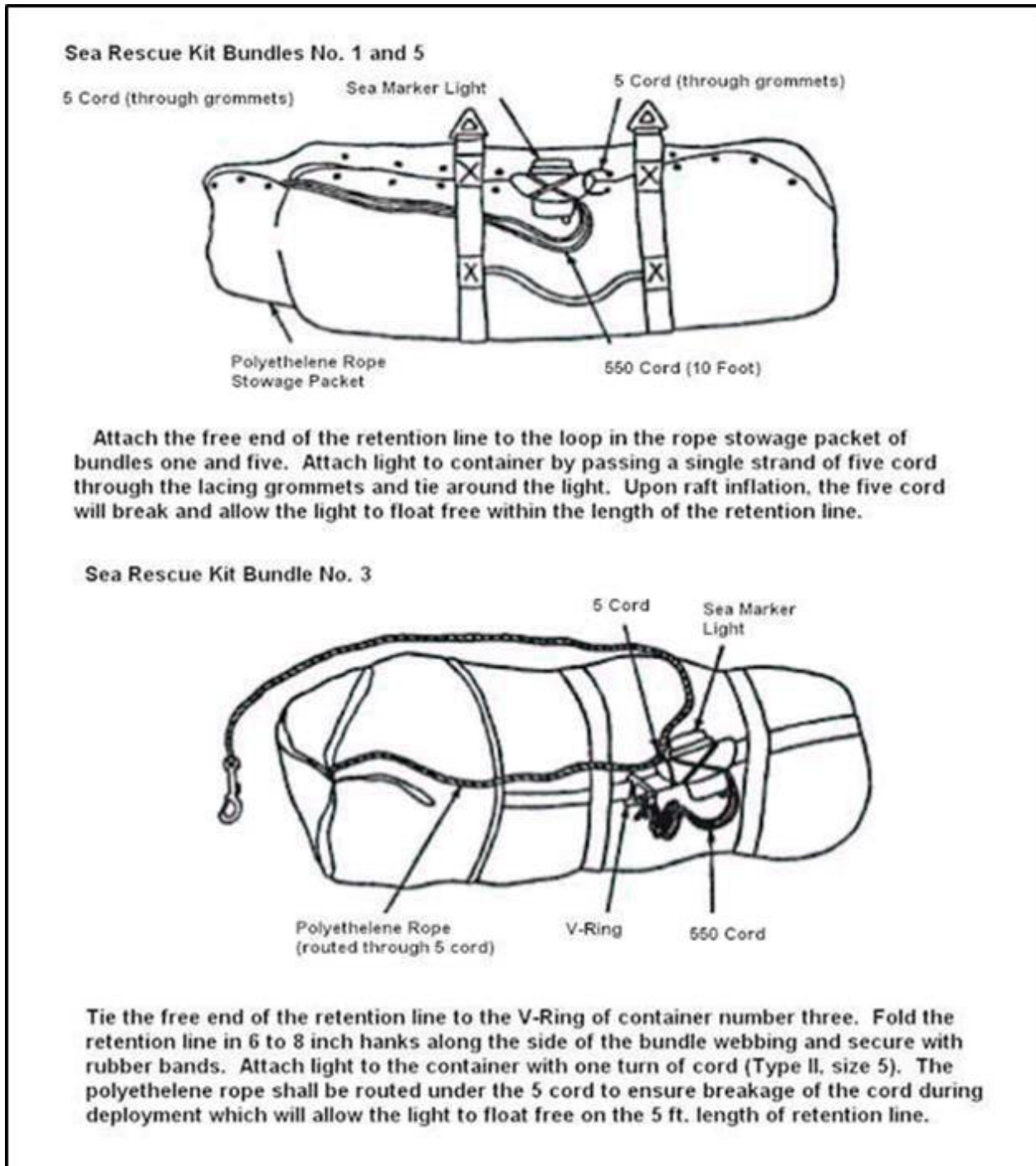

## 19.7. Pyrotechnics:

19.7.1. General. This section provides information in preparation for launching pyrotechnics. Refer to TO 11A10-24-7, *Storage and Maintenance Procedures-Aircraft Parachute Flares*, TO 11A10-26-7, *Storage and Maintenance Procedures-Pyrotechnic Signals*, TO 11A10-27-7, *Specialized Storage and Maintenance Procedures-Simulators (Battlefield Effects)* and TO 11A10-28-7, *Storage and Maintenance Procedures-Infrared TRKG Flares*.

19.7.1.1. Hazards. In general, pyrotechnics contain materials of a hazardous nature. Even though each of the ingredients in a pyrotechnic composition may be relatively stable within itself, it may react with one or more of the other materials to cause deterioration and create an even greater hazard. Pyrotechnics are more dangerous than many other types of ammunition because they are more easily activated. These items should not be handled roughly or exposed to moisture. When subjected to fire, most pyrotechnics burn with intense heat.

19.7.1.2. Toxic Hazards. Many chemicals used in pyrotechnic devices are poisonous if taken internally. This also applies to the residues of burned pyrotechnics. From an inhalation standpoint, the products of pyrotechnic devices and smoke generators present a serious problem. Although most of the smoke and fumes given off by pyrotechnics are considered nontoxic, heavy concentrations in closely confined spaces are dangerous and may be lethal, for they reduce the amount of available oxygen in the air.

19.7.2. Handling. Besides the hazardous basic compositions, pyrotechnics contain sensitive elements such as fuses, friction compositions and primers. Pyrotechnics should be handled with care and protected against moisture, shock, friction or heat. Care should be taken to avoid premature ignition or damage that may cause failure when fired. Boxes containing pyrotechnics should not be dropped or thrown. Protective or safety devices should not be removed until just before use. Care should be taken to avoid damage to fiber cases and rip cords located outside the casing of flares. Pyrotechnics should be handled so as to avoid denting or deforming the barrel or case. Do not use pyrotechnics that are dented, deformed, cracked, broken, or have signs of advanced rust, looped closing, or have shipping covers with an illegible lot number, manufacture date, or other required identifying information. Pyrotechnics will be handled only under the supervision of a competent, qualified person. Most pyrotechnics burn with intense heat; therefore, personnel should be adequately prepared to handle an emergency situation (e.g., heat resistant gloves and broom). (T-2)

19.7.3. Storage. Units that have a requirement for storing pyrotechnics will obtain a license from the host base. (T-2)

19.7.4. Issue Procedures. Pyrotechnics that have been issued for training purposes will be marked in bold capital letters with the word TRAINING. (T-2) These pyrotechnics will always be stored separately from operational stock within storage areas. (T-2)

19.7.5. Safety. All of the pyrotechnics described contain combustible chemicals which, when ignited, generate a flame or smoke (or combination of both) for a broad variety of purposes. These purposes include visual signaling, area or target illumination, and point marking. Most are intended to burn with intense heat.

19.7.5.1. Initiation Mechanism. Pyrotechnic devices normally are equipped with some type of safety pin, lock, or tape designed to prevent accidental activation of the initiation mechanism. Any pyrotechnic which shows sign of damage to safety features is considered unserviceable and must be carefully segregated for prompt disposition by Explosive Ordinance Disposal (EOD). (T-2)

19.7.5.2. Accidental Initiation. If a pyrotechnic device should be accidentally ignited, in all cases its functioning will result in a fire hazard. The gases generated by this combustion

could present a serious toxic hazard. Signaling devices containing propellant charges create an extremely dangerous missile hazard if accidentally ignited.

19.7.5.3. Fighting Pyrotechnic Fires. Pyrotechnic compositions characteristically contain their own oxidants, and therefore do not depend upon atmospheric oxygen for combustion. For this reason, excluding air from a pyrotechnic fire usually is ineffective. Many pyrotechnic mixtures, particularly illuminating flare compositions, burn with intense heat up to 4,500° F. Normally, available extinguishers are of little or no value in fires of this kind, and in addition, may produce toxic or poisonous gases.

19.7.5.4. Safe Altitudes and Distances. Flares not entirely burned out and cooled when they land may ignite combustible material. Safe altitudes and distances depend upon the burning time, rate of descent, and drift of the flare. Such factors will be considered in determining minimum altitudes and distances of release. Signal flares are also a potential fire hazard when the parachute fails to support the signal properly. **CAUTION:** Flares will not be launched over areas subject to fire except in an extreme emergency. (T-3) If such an emergency exists, flares should be dropped from sufficient altitude to allow complete burnout before hitting the surface.

19.7.5.5. Reporting Instructions. Prepare instructions for mishaps, accidents and incidents in accordance with AFI 91-204, *Safety Investigations and Reports*. Prepare unsatisfactory reports in accordance with TO00-35D-54, *USAF Deficiency Reporting, Investigation and Resolution*.

#### 19.7.6. Pyrotechnics Launching:

19.7.6.1. Personnel launching pyrotechnics through open doors or hatches will wear a restraint harness or parachute, and will have armored or heat resistant gloves and a broom or wood stick readily available in case of fire. (T-2) Wearing nomex gloves when deploying pyrotechnics is recommended. When manually launching parachute flares from the aircraft, only the cargo ramp will be opened unless the mission dictates otherwise. (This is to assist in eliminating pyrotechnics missile hazard.) (T-2)

19.7.6.2. The aircraft will be prepared for flare jettison prior to handling any pyrotechnic. (T-2) Only the cargo ramp will be opened unless mission requirements dictate otherwise. (T-2) All parachute flares hand-launched from the ramp will use a 10-foot lanyard (Refer to [Figure 19.5](#)). The flare will be hand-launched upon command of the PIC or designated crew member. (T-3) **CAUTION:** Personnel launching flares will ensure the lanyard system is clear of extremities and equipment before launching. (T-2) Excess lanyard should be accordion folded and held against the body of the flare or taped with paper tape.

#### 19.7.7. Pyrotechnics Description and Operation:

##### 19.7.7.1. LUU-2/B, 2A/B; Flare, Aircraft Parachute.

19.7.7.1.1. Description. The LUU-2/B, 2A/B is an air-launched parachute flare. It is 36 inches long, 4.875 inches in diameter and rated as providing 2-million candlepower illumination for approximately 300 seconds (5 minutes). Some uses are illumination of areas for crash landing, ditching, landing, target, dropping of supplies, hovering of rescue aircraft, etc.

- 19.7.7.1.2. Operation. Remove the flare from the shipping container and set desired feet of fall in the flare timer end cap. A setting of 500 feet represents a time delay of 6.3 seconds. A launch altitude of 3,000 feet AGL is recommended and will provide a light at 2,500 feet AGL. The flare descends approximately 2,500 feet during burning and will burn out and dump at ground level. The snap hook in the lanyard package of the flare shipping container may be used for the flare attaching end. The 10-foot lanyard secured to a tie-down ring near the aft end of the ramp will be attached to the lanyard or to the timer dial knob. Upon launch signal, toss the flare overboard from the rear of the ramp, or floor jettison port with ignition end out first (ignition end is opposite from the timer end cap). A force of 30 to 35 pounds is required to extract the timer dial knob and drogue cover strip. The knob and cover strip will remain with the static line. Retrieve the static line and remove the timer dial knob from the snap hook. Stow the timer dial knob until mission is over; then dispose of all residue. (T-2)
- 19.7.7.2. LUU-4B; Flare, Aircraft Parachute:
- 19.7.7.2.1. Description. The LUU-4/B is an air launched parachute flare. It is 25.5 inches long, 4.875 inches in diameter, and rated as providing 1.6-million candlepower illumination for approximately 180 seconds (3 minutes). Uses are the same as the LUU-2/B, 2A/B.
- 19.7.7.2.2. Operation. The flare altitude should be planned so as that burnout occurs approximately 300 feet AGL overwater and higher over land. Recommend maximum deployment airspeed of 200 KIAS/KCAS due to possible failure of the parachute system. Manual launch procedures are the same as LUU-2/B procedures.
- 19.7.7.3. LUU-2/B, LUU-2A/B, LUU-4/B Emergency Procedures:
- 19.7.7.3.1. Premature timer release/ignition in aircraft or storage container: Nylon cord - Cut; Container - Taped; Pilot - Notified. **WARNING:** In the event the timer end cap is separated from the flare, do not pull on the nylon cord or the parachute. An approximate 50-pound pull on one of the suspension cables of the parachute will cause the flare to ignite. Return the flare to the shipping container and turn flare over to EOD at mission completion. (T-2)
- 19.7.7.3.2. Pre-ignition of Flare: Jettison flare or container immediately; Pilot-notified. **WARNING:** In the event of flare ignition, an attempt will be made to jettison the flare. (T-2) In event of candle ignition, intense light, heat and lethal gas will be experienced. Adequate respiratory, eye and hand protection will be sought as soon as emergency permits. Flare suppression will be attempted as a last resort. (T-2)
- 19.7.7.3.3. Flare breakaway fails to release: Static line - Cut; Pilot - Notified. **WARNING:** Packaged aircraft parachute flares dropped in excess of 3 feet or unpackaged flares dropped in excess of 1 foot shall be considered unserviceable. (T-2)
- 19.7.7.4. MK-6 MOD 3; Signal, Smoke, and Illumination, Aircraft:
- 19.7.7.4.1. Description. This signal marker provides long burning (approximately 40 minutes) surface smoke and illumination for day or night use. It is used to mark sightings at sea, make sea evaluations, marking a sea lane for night water landing, and

to simulate targets for the firing of weapons. It may be used to provide smoke on land surfaces if a fire hazard does not exist.

19.7.7.4.2. Operation. Prior to launching the signal marker, remove the adhesive tape covering the pull ring. **WARNING:** The smoke signal has a 90 second ignition delay and must be launched immediately after the igniter has been actuated. (T-2) **WARNING:** Packaged signal markers dropped in excess of 10 feet or unpackaged signals dropped in excess of 5 feet shall be considered unserviceable, and reported to OO-ALC/MMWR, Hill AFB, UT 84056-5609. (T-2) **WARNING:** Do not prepare more than 2 marks at a time, and do not remove more than 4 marks at a time from the storage container in-flight. (T-3) **Note:** Do not remove the four square patches of adhesive tape covering the metal caps in the holes from which flame and smoke issue after ignition of the candle. (T-2) At the time the signal is launched, the pull-type igniter is actuated by hand.

19.7.7.5. MK-25 MOD 3; Marker, Location Marine:

19.7.7.5.1. Description. This marker was designed for day or night use for all surface reference point marking purposes that call for smoke and flame in the 13 to 18 minute range.

19.7.7.5.2. Operation. To activate the marker, the base plate must be rotated from the safe to the armed position to allow the battery cavity ports to be opened. Open the ports by pressing the two brass-colored port plugs into the battery cavity using the thumb and forefinger. A one-pound force is required for plug removal. This device is considered to be a sealed unit until either or both base plugs have been pushed in. (T-2) **WARNING:** The MK-25 must not be returned to storage with the base plugs pushed in. (T-2) The nose end of this marker must be kept out of line with the body or with other personnel at all times. (T-2) If marker is initiated, the nose plug is expelled with considerable force creating a missile hazard

19.7.7.5.3. Special Precautions. This marker may be converted for use in fresh water by adding 1/2 or 3/4 ounces of table salt or two salt tablets through the base plugs. **WARNING:** Converted markers must be used after adding salt. (T-2) They must not be returned to storage. (T-2) If not used, they must be jettisoned in-flight, overwater. (T-2) **CAUTION:** Be sure salt is not exposed to moisture before and during the conversion process, as moist salt may cause marker to ignite. **CAUTION:** Packaged flares dropped in excess of 6 feet or unpackaged flares dropped in excess of 3 feet shall be considered unserviceable. (T-2) Report to OO-ALC/MMWR, Hill AFB, UT 84056. **Note:** Converted markers will not perform as reliably in fresh water as unconverted markers in seawater.



Figure 19.5. Rescue Lanyard.

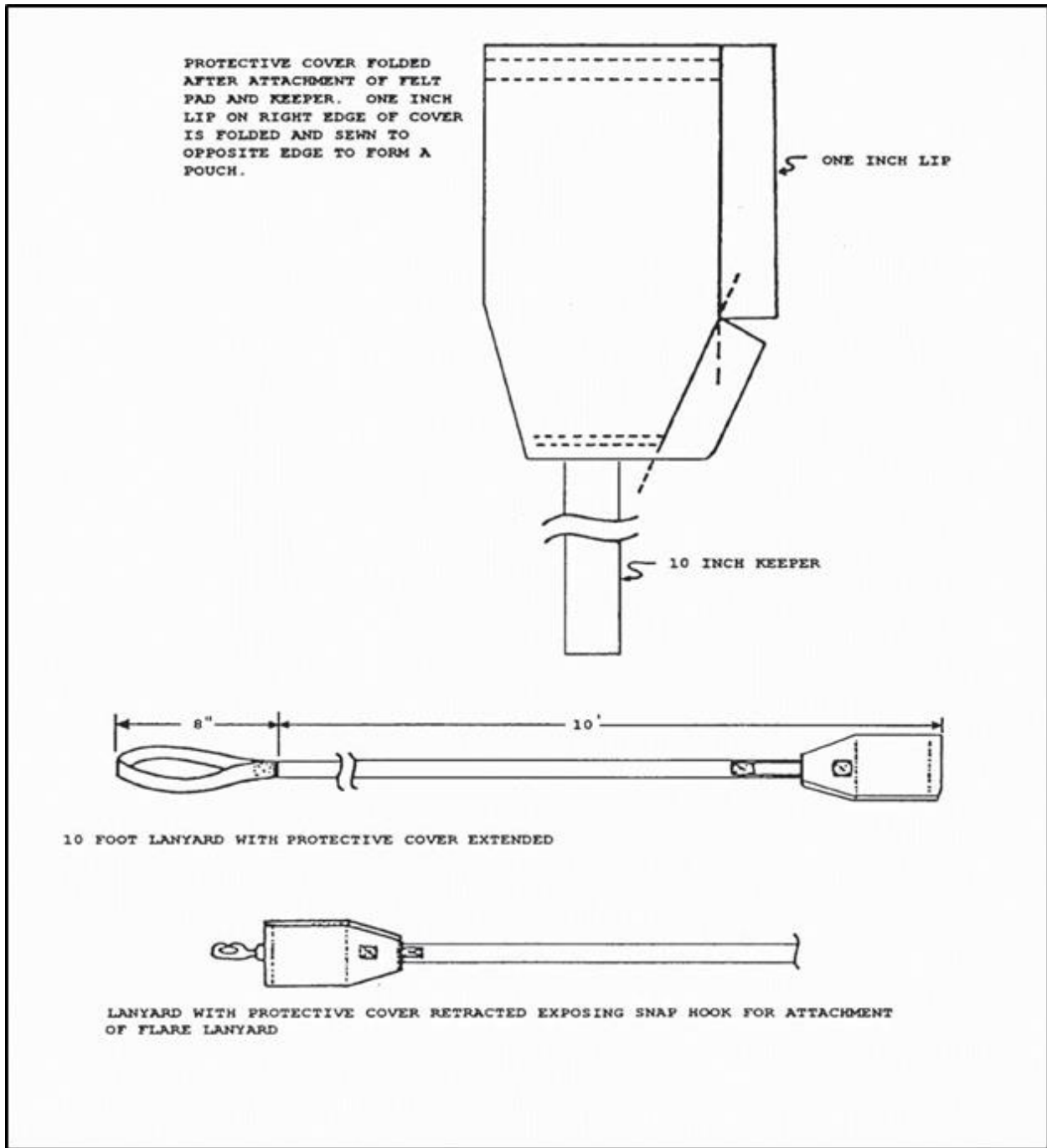

MARK D. KELLY, Lt Gen, USAF  
Deputy Chief of Staff, Operations

**Attachment 1****GLOSSARY OF REFERENCES AND SUPPORTING INFORMATION*****References***

- AFH 11-203, Volume 1, *Weather for Aircrews*, 12 January 2012
- AFI 10-706, *Electronic Warfare (EW) Operations*, 13 May 2014
- AFI 10-801, *Defense Support of Civil Authorities*, 22 December 2015
- AFI 11-200, *Aircrew Training, Standardization/Evaluation and General Operations Structure*, 20 September 2018
- AFI 11-202, Vol 1, *Aircrew Training*, 25 June 2014
- AFI 11-202, Vol 2, *Aircrew Standardization/Evaluation Program*, 5 December 2018
- AFI 11-202, Vol 3, *General Flight Rules*, 9 August 2016
- AFI 11-214, *Air Operations Rules and Procedures*, 13 August 2012
- AFI 11-215, *Flight Manuals Program*, 24 March 2019
- AFI 11-230, *Instrument Procedures*, 24 July 2019
- AFI 11-231, *Computed Air Release Point Procedures*, 31 August 2005
- AFI 11-235, *Forward Area Refueling Point (FARP) Operations*, 30 May 2019
- AFI 11-253, *Managing Off-Station Purchases of Aviation Fuel and Ground Services*, 18 August 2013
- AFI 11-2KC-135, Vol 3, Addenda C, *KC-135 Special Operations*, 26 June 2018
- AFI 11-301, Vol 1, *Aircrew Flight Equipment (AFE) Program*, 9 October 2017
- AFI 11-401, *Aviation Management*, 9 December 2010
- AFI 11-401, ANG Supplement, *Aviation Management*, 18 April 2017
- AFI 11-409, *High-Altitude Airdrop Mission Support Program*, 8 September 2019
- AFI 13-217, *Drop Zone and Landing Zone Operations*, 10 May 2010
- AFI 21-101, *Aircraft and Equipment Maintenance Management*, 20 May 2015
- AFI 23-111, *Management of Government Property in Possession of the Air Force*, 18 November 2018
- AFI 23-201, *Fuels Management*, 19 Jun 2014
- AFI 24-203, *Preparation and Movement of Air Force Cargo*, 14 May 2012
- AFI 31-401, *Information Security Program Management*, 19 August 2009
- AFI 33-360, *Publications and Forms Management*, 30 December 2015
- AFI 48-123, *Medical Examinations and Standards, Change 2*, 4 November 2013
- AFI 91-202, *The US Air Force Mishap Prevention Program*, 23 June 2015

AFI 91-204, *Safety Investigations and Reports*, 26 April 2018

AFJ 13-210, *Joint Airdrop Inspection Records, Malfunction/Incidents, Investigations and Activity Reporting*, 23 June 2009

AFJI 11-204, *Operational Procedures for Aircraft Carrying Hazardous Materials*, 11 November 1994

AFMAN 10-206, *Operational Reporting*, 18 Jun 2018

AFMAN 11-217, *Flight Operations*, 9 June 2019

AFMAN 11-2MC-130J, Vol 1, *MC-130J Aircrew Training*, TBD

AFMAN 11-2MC-130J, Vol 2, *MC-130J Aircrew Evaluation Criteria*, 27 September 2018

AFMAN 11-2EC/MC-130J, Vol 3, Addenda A, *EC/MC-130J Operation Configuration/Mission Planning*, 27 June 2015

AFMAN 11-411, *Special Forces Military Free-Fall Operations*, 31 December 2004

AFMAN 13-212, Vol 1, *Range Planning and Operations*, 21 June 2018

AFMAN 23-110, *USAF Supply Manual*, 1 April 2009

AFMAN 23-110CD, *Air Force Supply Systems Electronic Publishing Library*, 1 April 2009

AFMAN 24-204, *Preparing Hazardous Materials for Military Air Shipments*, 12 July 2017

AFMAN 33-363, *Management of Records*, 1 March 2008

AFPAM 32-2004, *Aircraft Fire Protection for Exercises and Contingency Response Operations*, 21 April 2010

AFPAM 90-803, *Risk Management (RM) Guidelines and Tools*, 10 February 2013

AFPD 11-2, *Aircrew Operations*, 30 January 2019

AFSOCMAN 11-201, *Hostile Environment Repair Procedures*, 4 September 2013

AFTO 11N-20-11, (C) *General Firefighting Guidance*

AFTTP 3-1.IPE, (S) *Combat Aircraft Fundamentals Integrated Planning & Employment*, 27 August 2018

AFTTP 3-1.E/MC-130J, (S) *Tactical Employment E/MC-130J*, 22 August 2018

AFTTP 3-1.Threat Guide, (S) *Threat Reference Guide and Countertactics*, 30 October 2017

AFTTP 3-3.E/MC-130J, *Combat Aircraft Fundamentals MC-130J*, 22 August 2018

ATP-3.3.4.2, *NATO Air To Air Refueling Procedures*, April 2019

CJCSM 3212.02, *Performing Electronic Attack in the United States and Canada for Tests, Training, and Exercises*

DLA Energy-I-5, *Fuel Card Program*, 14 December 2011

DoDI 4515.13-R, *Air Transportation Eligibility*, 22 November 2016

DoDM 4140.25-M, *DoD Management of Bulk Petroleum Products*, 31 August 2018

DoDM 4140.25-M, Vol 2, *DoD Management of Bulk Petroleum Products*, 31 August 2018

DTR 4500.9-R-Part V, *DoD Preclearance Program Customs and Agricultural Inspections*, January 2011

FAA 7610.4V, *Special Military Operations*, 1 September 2017

Flight Information Publication AP1, *Area Planning: North and South America*

Flight Information Publication AP2, *Area Planning: Europe, Africa, Middle East*

Flight Information Publication AP3, *Area Planning: Pacific, Australasia, Antarctica*

Flight Information Publication AP4, *Area Planning: Eastern Europe, Asia*

Flight Information Publication FIH, *Flight Information Handbook*

Flight Information Publication GP, *General Planning*

IAMSAR, *International Aeronautical and Maritime Search and Rescue Manual*, 24 May 2010

JP 3-50, *Personnel Recovery*, 5 January 2007

Title 40 CFR, Parts 260-265, *Protection of Environment*

TO 00-20-1, *Aerospace Equipment Maintenance Inspection, Documentation, Policies, and Procedures*, 15 June 2011

TO 00-25-172, *Ground Servicing of Aircraft and Static Grounding/Bonding*, 10 February 2010

TO 00-35D-54, *USAF Deficiency Reporting, Investigation, and Resolution*

TO 1-1B-50, *Weight and Balance*, 1 April 2008

TO 1-1-691, *Cleaning and Corrosion Prevention and Control, Aerospace and Non-aerospace Equipment*

TO 1C-130(M)J-9, *Cargo Loading Manual*, 1 November 2014

TO 1C-130(M)J-9CL-1, *Cargo Loading Checklist USAF Series C-130J Aircraft*, 1 November 2014

TO 1C-130(M)J-1, *Flight Manual*, 31 May 2018

TO 1C-130(M)J-1-1, *Flight Manual Performance Data*, 1 November 2014

TO 1C-130(M)J-1-4, *Communication/Navigation/Identification Management System (CNI-MS) Operator Manual*, 1 November 2014

TO 1C-130(M)J-5, *Weight and Balance*, 1 November 2014

TO 11A10-24-7, *Storage and Maintenance Procedures—Aircraft Parachute Flares*, 22 May 2012

TO 11A10-26-7, *Storage and Maintenance Procedures—Pyrotechnic Signals*, 23 April 2012

TO 11A10-27-7, *Specialized Storage and Maintenance Procedures—Simulators (Battlefield Effects)*, 15 March 2006

TO 11A10-28-7, *Storage and Maintenance Procedures—Infrared TRKG Flares*, 1 May 2003

TO 13C7-1-5, *Airdrop of Supplies and Equipment: Rigging Airdrop Platforms*, 8 June 2006

TO 13C7-1-11, *Airdrop of Supplies and Equipment: Rigging Containers*, 2 September 2005

TO 13C7-51-21, *Airdrop of Supplies and Equipment: Rigging Loads for Special Operations*, August 2012

TO 37A-1-101, *General Instructions, USAF Fuel, Water and Lubricant Dispensing Equipment*

TO 37A9-7-2-1, *SFARE Operations and Maintenance Manual*, 1 November 2014

### ***Adopted Forms***

DD Form 175, *Military Flight Plan*

DD Form 175-1, *Flight Weather Briefing*

DD Form 365-3, *Chart C-Basic Weight and Balance Record*

DD Form 365-4, *Weight and Balance Clearance, Form F*

DD Form 1384, *Transportation Control and Movement Document*

DD Form 1385, *Cargo Manifest*

DD Form 1748, *Joint Airdrop Inspection Record*

DD Form 1748-2, *Airdrop Malfunction Report (Personnel-Cargo)*

DD Form 1801, *DoD International Flight Plan*

DD Form 1896, *DoD Fuel Identaplate*

DD Form 1898, *Fuel Sale Slip*

DD Form 1907, *Signature and Tally Record*

DD Form 2130-2, *C-130 A/B/E/H Load Plan*

DD Form 2131, *Passenger Manifest*

DD Form 2133, *Joint Airlift Inspection Record*

DD Form 2992, *Medical Recommendation for Flying or Special Operational Duty*

AF Form 15, *USAF Invoice*

AF Form 70, *Pilot's Flight Plan and Flight Log*

AF Form 127, *Traffic Transfer Receipt*

AF Form 457, *USAF Hazard Report*

AF Form 651, *Hazardous Air Traffic Report (HATR)*

AF Form 664, *Aircraft Fuels Documentation Log*

AF Form 711B, *USAF Mishap Report*

AF Form 791, *Aerial Tanker In-flight Issue Log*

AF Form 847, *Recommendation for Change of Publication*

AF Form 853, *Bird Strike Report*

AF Form 1297, *Temporary Issue Receipt*  
AF Form 1994, *Fuels Issue/Defuel Document*  
AF Form 2282, *Statement of Adverse Effect-Use of Government Facilities*  
AF Form 3823, *Drop Zone Survey*  
AF Form 4015, *High-Altitude Release Point (HARP) Computation*  
AF Form 4018, *Computed Air Release Point (CARP) Computation*  
AF Form 4051, *Low-level Flight Plan and Log*  
AF Form 4064, *C-130 Takeoff and Landing Data*  
AF Form 4108, *C-130 Fuel Log*  
AF Form 4116, *C-130 Flight Plan Record*  
AF Form 4118, *Self-Contained Approach (SCA) Planning Form*  
AF Form 4121, *FCIF Currency Record*  
AF Form 4124, *Flight Crew Information Guide*  
AF Form 4139J, *Special Operations C-130 CS In-Flight Refueling Worksheet*  
AF Form 4327A, *Crew Flight (FA) Authorization*  
AFTO Form 46, *Aircrew Flight Equipment*  
AFTO Form 781, *ARMS Aircrew/Mission Flight Data Document*  
AFTO Form 781A, *Maintenance Discrepancy and Work Document*  
AFTO Form 781H, *Aerospace Vehicle Flight Status and Maintenance Document*  
CBP Form 6059B, *Customs Declaration*  
CBP Form 7507, *General Declaration*  
SF 44, *Purchase Order Invoice Voucher*

### ***Abbreviations and Acronyms***

**AAR**—Air-to-Air Refueling  
**AC**—Aircraft Commander  
**ACC**—Air Combat Command  
**ACAWS**—Advisory Caution and Warning System  
**ACFP**—Advanced Computer Flight Plan  
**ACP**—Allied Communications Publication  
**ADC**—Air Data Computer  
**ADF**—Automatic Direction Finding System  
**ADIZ**—Air Defense Identification Zone

**ADS**—Aerial Delivery System  
**AETC**—Air Education Training Command  
**AF**—Air Force  
**AFCS**—Automated Flight Control System  
**AFF**—Automated Form F  
**AFFSA**—Air Force Flight Standards Agency  
**AFI**—Air Force Instruction  
**AFJI**—Air Force Joint Instruction  
**AFMC**—Air Force Materiel Command  
**AFRC**—Air Force Reserve Command  
**AFSC**—Air Force Specialty Code  
**AFSOC**—Air Force Special Operations Command  
**AFTO**—Air Force Technical Order  
**AFTTP**—Air Force Tactics, Techniques, and Procedures  
**AGL**—Above Ground Level  
**AI**—Airborne Intercepts  
**ALCE**—Airlift Control Element  
**ALS**—Approach Lighting System  
**ALT**—Altitude  
**ALTRV**—Altitude Reservation  
**AMAX**—Adjusted Max Effort Rotation Speed  
**AMC**—Air Mission Commander  
**AMFLMETO**—Adjusted Minimum Field Length Maximum Effort Take Off  
**AMU**—Avionic Management Unit  
**AOR**—Area of Responsibility  
**APPR**—Approach  
**APU**—Auxiliary Power Unit  
**ARC**—Air Reserve Component  
**AREP**—Air Refueling Exit Point  
**ARFF**—Aircraft Rescue Fire-fighting Requirements  
**ARIP**—Air Refueling Initial Point  
**ASRR**—Airfield Suitability and Restriction Report

**A/T**—Auto-Throttle System  
**ATA**—Actual Time of Arrival  
**ATC**—Air Traffic Control  
**ATCS**—Automatic Thrust Control System  
**ATM**—Air Traffic Management  
**ATO**—Air Tasking Order  
**ATOC**—Air Terminal Operations Center  
**ATTLA**—Air Transportation Test Loading Agency  
**AVPOL**—Aviation Petroleum, Oil, and Lubricants  
**BA/ECS**—Bleed Air/Environmental Control System  
**BAQ**—Basic Aircraft Qualified  
**BAU**—Bus Adapter Unit  
**BIU**—Bus Interface Unit  
**BMC**—Basic Mission Capable  
**BRNAV**—Basic Area Navigation  
**C2**—Command and Control  
**CADC**—Combined Air Data Computer  
**CARP**—Computed Air Release Point  
**CAT**—Category  
**CAT**—Consolidated Airdrop Tool  
**CBP**—Customs Border Protection  
**CC**—Commander  
**CAA**—Competent Authority Approval  
**CCA-LVADS**—Combat Craft Assault – Low Velocity Aerial Delivery System  
**CCC**—Command and Control Center  
**CCT**—Combat Control Team  
**CDE**—Collateral Damage Estimate  
**CDS**—Container Delivery System  
**CDI**—Course Deviation Indicator  
**CEOI**—Command Electronic Order of Information  
**CF**—Customs Form  
**CFL**—Critical Field Length



**CFP**—Computer Flight Plan  
**CFPS**—Computer Flight Planning Software  
**CHK**—Check  
**CHUM**—Chart Updating Manual  
**CLO**—Combat Logistics Operations  
**CMDS**—Countermeasures Dispensing System  
**CNBP**—Communication/Navigation/Breaker Panel  
**CNDC**—Canadian National Defense Contract  
**CNI**—Communication/Navigation/Identification  
**CNI-MU**—Communication/Navigation/Identification Management Unit  
**CNI-SP**—Communication/Navigation/Identification System Processor  
**COE**—Certificate of Equivalency  
**COMAFFOR**—Commander Air Force Forces  
**COMAFSOF**—Commander Air Force Special Operations Forces  
**COMSEC**—Communications Security  
**CONUS**—Continental United States  
**CRL**—Container Ramp Load  
**CRM**—Crew Resource Management  
**CRO**—COMSEC Responsible Officer  
**CRRC**—Combat Rubber Raiding Craft  
**CSO**—Combat Systems Operator  
**CVR**—Centerline Vertical Restraint  
**CVR**—Cockpit Voice Recorder  
**DA**—Digital Autopilot  
**DACO**—Departure Airfield Controlling Officer  
**DCS**—Defense Courier Service  
**DD**—Department of Defense Form  
**DESC**—Defense Energy Support Center  
**DFDR**—Digital Flight Data Recorder  
**DFSC**—Defense Fuel Supply Center  
**DH**—Decision Height  
**DIP**—Diplomatic

**DMC**—Deputy Mission Commander  
**DME**—Distance Measuring Equipment  
**DoD**—Department of Defense  
**DOT**—Department of Transportation  
**DSN**—Defense Switched Network  
**DSO**—Direct Support Operator  
**DSR**—Deployed Status Report  
**DST**—Degraded Systems Training  
**DTR**—Defense Transportation Regulation  
**DVT**—Divert  
**DZ**—Drop Zone  
**EAR**—End Aerial Refueling  
**ECB**—Electronic Circuit Breakers  
**ECHS**—Enhanced Cargo Handling System  
**ECM**—Electronic Countermeasures  
**EGI**—Embedded Global Positioning/Inertial Navigation System  
**EL**—Electroluminescent  
**EO**—Electro Optical  
**EP**—Emergency Procedure  
**EP**—Evaluator Pilot  
**EPJS**—Emergency Parachute Jettison System  
**EPOS**—Emergency Portable Oxygen System  
**ER**—Exceptional Release  
**ERCC**—Engine Running Crew Change  
**ERO**—Engines Running Onload/Offload  
**ESA**—Emergency Safe Altitude  
**ETA**—Estimated Time of Arrival  
**ETCAS**—Enhanced Traffic Collision Avoidance System  
**ETE**—Estimated Time En route  
**ETP**—Equal Time Point  
**FAA**—Federal Aviation Administration  
**FADEC**—Full Authority Digital Electronic Controls

**FAF**—Final Approach Fix  
**FAM**—Forward Area Manifold  
**FARE**—Forward Area Refueling Equipment  
**FARP**—Forward Area Refueling Point  
**FBO**—Fixed Base Operator  
**FCF**—Functional Check Flight  
**FCG**—Foreign Clearance Guide  
**FCIF**—Flight Crew Information File  
**FD**—Flight Director  
**FIH**—Flight Information Handbook  
**FL**—Flight Level  
**FLCV**—Fuel Level Control Valve  
**FLIP**—Flight Information Publications  
**FM**—Frequency Modulation  
**FMP**—Flight Manuals Program  
**FOB**—Fuel On Board  
**FOD**—Foreign Object Damage  
**FODS**—Fire and Overheat Detection System  
**FOL**—Forward Operating Location  
**FOM**—Figure Of Merit  
**FP**—First Pilot  
**FPM**—Feet Per Minute  
**FS**—Fuselage Station  
**FSAF**—First Suitable Airfield  
**FSSZ**—Fuel Servicing Safety Zone  
**FTD**—Forward Travel Distance  
**FWAAR**—fixed wing air to air refueling  
**G/A**—Go-Around  
**GCAS**—Ground Collision Avoidance System  
**GDSS**—Global Decision Support System  
**GMRS**—Ground Mark Release System  
**GPS**—Global Positioning System

**GS**—Glide Slope  
**GS**—Ground Speed  
**GSI**—Glide Slope Indicator  
**HAAR**—Helicopter Air-to-Air Refueling  
**HAHO**—High-Altitude High-Opening  
**HALO**—High-Altitude Low-Opening  
**HARP**—High-Altitude Release Point  
**HAT**—Height Above Touchdown  
**HATR**—Hazardous Air Traffic Report  
**HERP**—Hostile Environment Repair Procedures  
**HERK**—Hostile Environment Repair Kit  
**HDD**—Heads Down Displays  
**HDP**—Hose Deployment Personnel  
**HE**—Heavy Equipment  
**HF**—High Frequency  
**HIU**—Headset Interface Unit  
**HQ**—Headquarters  
**HRS**—Hot Refueling Supervisor  
**HSSLADS**—High-Speed Low-Level Delivery System  
**HUD**—Heads Up Display  
**IAW**—In Accordance With  
**ICAO**—International Civil Aviation Organization  
**ICS**—Intercommunication System  
**I-CDS**—Improved Container Delivery System  
**IFF**—Identification Friend or Foe  
**IFG**—In Flight Guide  
**IL**—Instructor Loadmaster  
**IFR**—Instrument Flight Rules  
**ILS**—Instrument Landing System  
**IMC**—Instrument Meteorological Conditions  
**INAV**—Integrated Navigation  
**INS**—Inertial Navigation System

**INU**—Inertial Navigation Unit  
**IP**—Initial Point  
**IP**—Instructor Pilot  
**IR**—Infrared  
**ISB**—Intermediate Staging Base  
**ITU**—International Telecommunications Union  
**JAI**—Joint Airdrop Inspection  
**JCET**—Joint Combined Exchange Training  
**JMD**—Jumpmaster Directed Airdrop  
**JNCA**—Jet Navigation Chart-High-Altitude  
**JOG**—Joint Operations Graphic  
**JPADS**—Joint Precision Airdrop System  
**JPADS**—MP—JPADS Mission Planner System  
**JSOAC**—Joint Special Operations Air Component  
**KCAS**—Knots Calibrated Air Speed  
**kHz**—Kilohertz  
**KIAS**—Knots Indicated Air Speed  
**KTAS**—Knots True Air Speed  
**LAIRCM**—Large Aircraft Infrared Countermeasures  
**LAR**—Launch Acceptability Region  
**LAT**—Lateral Axis  
**LCADS-HV**—Low Cost Aerial Delivery System-High Velocity  
**LCADS-LV**—Low Cost Aerial Delivery System-Low Velocity  
**LCLA**—Low Cost Aerial Delivery System-Low-Altitude  
**LM**—Loadmaster  
**LRC**—Long Range Cruise  
**LPU**—Life Preserver Unit  
**LRNS**—Long Range Navigation Systems  
**LSAF**—Last Suitable Airfield  
**LSK**—Line Select Key  
**LUT**—Local User Terminals  
**LZ**—Landing Zone

**MAJCOM**—Major Command  
**MAP**—Missed Approach Point  
**MARSA**—Military Assumes Responsibility for Separation of Aircraft  
**MB**—Marker Beacon  
**MC**—Mission Copilot  
**MC**—Mission Computer  
**MDA**—Minimum Descent Altitude  
**MDF**—Mission Data Files  
**MDS**—Mission Design Series  
**MEL**—Minimum Equipment List  
**MEP**—Mission Essential Personnel  
**MFF**—Military Free-Fall  
**MFP**—Master Flight Plan  
**MFCD**—Multifunction Control Display  
**MFLMETO**—Minimum Field Length Maximum Effort Takeoff  
**MGM**—Mono-Pulse Ground Mode  
**MGT**—Measured Gas Temperature  
**MHz**—Megahertz  
**MHE**—Materiel Handling Equipment  
**MICAP**—Mission Impaired Capability/Awaiting Parts  
**MIL**—Military  
**MISREP**—Mission Report  
**MNPS**—Minimum Navigation Performance Specifications  
**MOA**—Memorandum of Agreement  
**MP**—Mission Pilot  
**MPC**—Master Plotting Chart  
**MPP**—Most Probable Position  
**MRPS**—Mission Record Playback System  
**MSA**—Minimum Safe Altitude  
**MSC**—Multiservice Corporation  
**MSL**—Mean Sea Level  
**MXG**—Maintenance Group

**NA**—North American  
**NAT**—North Atlantic Region  
**NATO**—North Atlantic Treaty Organization  
**NAV**—Navigation  
**NAVAID**—Navigation Aid  
**NC**—Noncurrent  
**NDB**—Non Directional Beacon  
**NEW**—Net Explosive Weight  
**NGB**—National Guard Bureau  
**NIU**—Nacelle Interface Unit  
**NM**—Nautical Miles  
**NOTAM**—Notice to Airmen  
**NORTHCOM**—United States Northern Command  
**NSN**—National Stock Number  
**NVG**—Night Vision Goggles  
**OAT**—Outside Air Temperature  
**OCONUS**—Outside Continental United States  
**OG**—Operations Group  
**OPARS**—Optimum Path Aircraft Routing System  
**OPCON**—Operational Control  
**OPREP**—Operations Report  
**ORM**—Operational Risk Management  
**OT&E**—Operational Test and Evaluation  
**P**—Pilot  
**PA**—Public Address  
**PAR**—Precision Radar Approach  
**PERF**—Performance  
**PF**—Pilot Flying  
**PFD**—Primary Flight Display  
**PFPS**—Portable Flight Planning Software  
**PI**—Point Of Impact  
**PIC**—Pilot In Command

**PITCH**—Pitch Axis  
**PLCU**—Pallet Lock Control Unit  
**PM**—Pilot Monitoring  
**PO**—Panel Operator  
**POK**—Passenger Oxygen Kit  
**POL**—Petroleum, Oil, and Lubricants  
**PRM**—Precision Runway Monitor  
**PSN**—Proper Shipping Name  
**PSP**—Pierced Steel Plank  
**PT**—Physiological Technician  
**QTY**—Quantity  
**RA**—Resolution Advisory  
**RADALT**—Radar Altimeter  
**RAMZ**—Rigging Alternate Method Zodiac  
**RATV**—Rapid All Terrain Vehicle  
**RCC**—Rescue Coordination Center  
**RCR**—Runway Condition Reading  
**REF**—Reference  
**REF/MODE**—Reference Mode  
**RFA**—Regulatory Flexibility Act  
**RGR**—Rapid Ground Refueling  
**RNAV**—Area Navigation  
**RNP**—Required Navigation Performance  
**RP**—Release Point  
**RPS**—Regulated Power Supply System  
**RRFL**—Required Ramp Fuel Load  
**RSC**—Runway Surface Condition  
**RVR**—Runway Visual Range  
**RVSM**—Reduced Vertical Separation Minimums  
**SAR**—Search and Rescue  
**SARSAT**—Search and Rescue Satellite-Aided Tracking  
**SAT**—Static Air Temperature



**SATB**—Standard Airdrop Training Bundles  
**SCA**—Self-Contained Approach  
**SF**—Standard Form  
**SIF**—Selective Identification Feature  
**SID**—Standard Instrument Departure  
**S/L**—Static Line  
**SM**—Statute Miles  
**SOF**—Special Operation Forces  
**SPINS**—Special Instructions  
**SPR**—Single Point Refuelling  
**SSEA**—System Safety Engineering Analysis  
**STAR**—Special Terminal Arrival  
**STD**—Standard  
**STS**—Special Tactics Squadron  
**STTO**—Start/Taxi/Take-Off  
**SUA**—Special Use Airspace  
**SYN**—Pitch Synchronization  
**TA**—Traffic Advisory  
**TAAR**—Tilt-Rotor Air-to-Air Refueling  
**TACAN**—Tactical Air Navigation  
**TAS**—True Airspeed  
**TAWS**—Terrain Awareness and Warning System  
**TCAS**—Traffic Alert Collision Avoidance System  
**TDZE**—Touchdown Zone Elevation  
**TFF**—Terminal Fuel Flow  
**TO**—Technical Order  
**TOA**—Time Of Arrival  
**TOC**—Top Of Cruise  
**TOLD**—Takeoff and Landing Data  
**TOT**—Time Over Target  
**TP**—Threat Penetration  
**TPC**—Tactical Pilotage Chart

**TR**—Transformer Rectifier  
**TRIADS**—Tri-Wall Aerial Delivery System  
**TSOC**—Theater Special Operations Command  
**UARRSI**—Universal Aerial Refueling Receptacle Slipway Installation  
**UHF**—Ultra High Frequency  
**UN**—United Nations  
**UNQ**—Unqualified  
**URL**—Unimproved Runway Landing  
**USAF**—United States Air Force  
**USAFWS**—United States Air Force Weapons School  
**USSOCOM**—United States Special Operations Command  
**VFR**—Visual Flight Rules  
**VHF**—Very High Frequency  
**VIRS**—Verbally Initiated Release System  
**VMC**—Visual Meteorological Conditions  
**V<sub>meto</sub>**—Maximum Effort Takeoff Speed  
**VOR**—**VHF Omni**—Directional Range  
**WF**—Wind Factor  
**WPS**—Weapons Squadron  
**WX**—Weather  
**XCDS-HS/LS**—Extracted CDS – High Speed/Low Speed

### *Terms*

**Air-to-Air Refueling**—Airborne fuel onload by receiver aircraft.

**Air Refueling Control Point (ARCP)**—The planned geographic point over which the receiver arrives in the precontact position with respect to the assigned tanker. For Helo AAR, the planned geographic point or coordinates over which the tanker arrives abeam the receiver and assumes formation lead.

**Air Refueling Control Time (ARCT)**—The planned time that the receiver and tanker will arrive over the ARCP.

**Air Reserve Components**—Units of the Air Force Reserve (AFR) and Air National Guard (ANG).

**Air Mission Commander**—The individual given the responsibility to accomplish part of the overall operation. When a formation is used to conduct the operation, this individual is in overall command of all formation aircraft.

**Auto Computed Air Release Point (CARP)**—An airdrop in which the CARP is automatically calculated in-flight by the navigation system. Automatic steering or manual steering indications are provided to guide the aircraft to the CARP.

**Basic Proficiency**—Crews or crew members qualified and current to fly the unit aircraft only on non-mission sorties.

**Basic Mission Capable**—Crews or crew members qualified and current to perform some portion of the unit mission, but who do not maintain mission ready status.

**Border Clearance**—Those clearances and inspections required to comply with federal, state, and local agricultural, customs, immigration, and immunization requirements.

**Category I Route**—Any route that does not meet the requirements of a category II route.

**Category II Route**—Any route on which the position of the aircraft can be accurately determined by the overhead crossing of a radio aid (NDB, VOR, TACAN) at least once each hour with positive course guidance between such radio aids.

**Chalk Number**—A number on an aircraft to identify and designate its position for loading and unloading.

**Combat Control Team**—A small task organized team of AF parachute and combat diver qualified personnel trained and equipped to rapidly establish and control drop, landing, and extraction zone air traffic in austere or hostile conditions. They survey and establish terminal airheads as well as provide guidance to aircraft for airlift operations. They provide command and control, and conduct reconnaissance, surveillance, and survey assessments of potential objective airfields or assault zones. They also can perform limited weather observations and removal of obstacles or unexploded ordinance with demolitions.

**Combat Entry Point**—A geographical point inbound to the objective area where the hostile environment is penetrated.

**Combat Offload**—Method by which palletized cargo is offloaded without Materials Handling Equipment (MHE).

**Command and Control Center (CCC)**—An agency used by a commander to plan, direct, or control operations. Each CCC provides supervision, guidance, and control within its assigned area of responsibility. For the purpose of this manual, CCCs include the AFSOC Command Center, Air Mobility Command Command Center, Command Post (CP), Air Mobility Elements (AME), Airlift Coordination Centers (ACC), Combat Control Teams, AFRC Headquarters Command Post (AFRC CP), NGB Field Support Center, and ARC wing or group operations centers and command posts.

**Commander Air Force Special Operations Command (COMAFSOC)**—The Commander of Air Force Special Operations Command.

**Commander Air Force Special Operations Forces (COMAFSOF)**—The commander designated by USCINCSOC for CONUS deployments or by theater SOC/CCs for overseas deployments, who is responsible for management of Air Force Special Operations Forces (AFSOF) within a theater, a geographic area, or a designated operation. The COMAFSOF is responsible to USCINCSOC for management of CONUS-deployed AFSOF or to the respective

SOC/CC for management of AFSOF theater-assigned AFSOF and is responsible to COMAFSOC for monitoring and management of AFSOF operating within the specific area of responsibility.

**Computed Air Release Point**—A computed air position at which the release of personnel, equipment, containers, and bundles is initiated to land on a specific point of impact (PI).

**Conference Hotel**—The name of the communication conference available to assist aircrews in coping with in-flight emergencies and conditions that require expertise in addition to that available onboard the aircraft.

**Contingency Mission**—A mission operated in direct support of an operation plan, operation order, disaster, or emergency.

**Drop Zone Controller (DZC)**—An individual on a drop zone required to monitor all airdrop operations except airdrop of Special Forces.

**Element**—A subdivision (normally 3 aircraft) flying in formation.

**Equal Time Point (ETP)**—The point along a route at which an aircraft may either proceed to the first suitable airport or return to the last suitable airport in the same amount of time based on all engines operating (see **Chapter 11**).

**Forward Operating Base**—An airfield without full support facilities used during mission operations for an undetermined and sometimes extended period of time.

**Hazardous Cargo or Materials**—Explosive, toxic, caustic, nuclear, combustible, flammable, biologically infectious, or poisonous materials that may directly endanger human life or property, particularly if misused, mishandled, or involved in accidents (AFJI 11-204, AFMAN 24-204, AFTO 11N-20-11, *General Firefighting Guidance*).

**Helicopter Air-to-Air Refueling (HAAR)**—Airborne fuel offload by MC-130 aircraft to a helicopter.

**High-Altitude High-Opening (HAHO)**—A high-altitude airdrop in which personnel deploy their parachutes immediately on exiting the aircraft (no programmed free fall).

**High-Altitude Low-Opening (HALO)**—Airdrop of personnel or containers using a programmed free fall (parachutist) or a staged parachute delivery.

**High-Altitude Release Point (HARP)**—A computed air position at which parachutists, equipment, containers, or bundles are released to land on a specific point of impact. A HARP is computed for all HAHO and HALO drops.

**Hung Ordnance**—Any ordnance or stores that fail to release, jettison, or fire and cannot be removed from the weapon prior to landing (ALE-40/47 chaff or flare squibs that fail to fire are not considered hung ordnance).

**Initial Point (IP)**—A point near drop zones or landing zones over which final course alterations are made to arrive at the specified zone.

**Interfly**—Inter-mixing of crew members from different units in the same aircrew or unit aircrews flying aircraft assigned to another unit.

**Joint Special Operations Task Force (JSOTF)**—A joint task force composed of special operations units from more than one Service, formed to carry out a specific special operation or

prosecute special operations in support of a theater campaign or other operations. The joint special operations task force may have conventional non-special operations units assigned or attached to support the conduct of specific missions.

**Live Ordnance**—Combat type ordnance incorporating explosive or incendiary material to include flares.

**Low-Level**—Operations conducted below 3,000 feet AGL.

**Maintenance Codes**—See Below

Fully Mission Capable (FMC).

Partially Mission Capable (PMC).

Not Mission Capable (NMC).

+ M (Maintenance), + S (Supply), + B (Both).

**Military Authority Assumes Responsibility for Separation of Aircraft**—A condition whereby the military services involved assume responsibility for separation between participating aircraft in the ATC system.

**Military Free Fall (MFF)**—HALO or HAHO airdrop operations.

**Minimum Safe Altitude (MSA)**—MSA is an intermediate altitude that will provide terrain clearance in VMC or IMC.

**Mission Capable**—Crews or crew members qualified and current to perform some portion of the unit mission, but who do not maintain mission ready status.

**Mission Essential Personnel (MEP)**—Individuals who perform essential duties in support of a particular aircraft, aircrew, or mission.

**Mission Ready**—Crews or crew members fully qualified and current to perform the unit mission.

**Net Explosive Weight (NEW)**—The actual weight in pounds of explosive mixtures or compounds, including the trinitrotoluene equivalent of energetic material, that is used in determination of explosive limits and explosive quantity data arcs. Also called NEW.

**Night Vision Goggles**—Self-contained, battery-operated devices that amplify light to enhance night vision.

**Offset Aiming Point (OAP)**—A reference, other than the actual target, used for aircraft positioning.

**Operating Weight**—Basic aircraft weight plus weight of crew members, crew baggage, steward's equipment, emergency, and extra equipment.

**Operational Control**—Transferable command authority that may be exercised by commanders at any echelon at or below the level of combatant command. Operational control may be delegated and is the authority to perform those functions of command over subordinate forces involving organizing and employing commands and forces, assigning tasks, designating objectives, and giving authoritative direction necessary to accomplish the mission. Operational control includes authoritative direction over all aspects of military operations and joint training necessary to accomplish missions assigned to the command. Operational control should be exercised through the commanders of subordinate organizations. Normally this authority is exercised through

subordinate joint force commanders and service and/or functional component commanders. Operational control normally provides full authority to organize commands and forces and to employ those forces as the commander in operational control considers necessary to accomplish assigned missions. Operational control does not, in and of itself, include authoritative direction for logistics or matters of administration, discipline, internal organization or unit training.

**Payload**—1. The sum of the weight of passengers and cargo that an aircraft can carry. 2. The load (expressed in tons of cargo or equipment, gallons of liquid, or number of passengers), which the vehicle is designed to transport under specified conditions of operation, in addition to its unladen weight.

**Point of Impact (PI)**—The point on the drop zone where the first airdropped parachutist or cargo item lands or is expected to land.

**Quick Turn**—A set of procedures designed to expedite the movement of selected missions by reducing ground times at en route or turn around stations.

**Self-Contained Approach**—An approach conducted using self-contained, onboard navigation systems.

**Serial**—Any number of aircraft under one commander, usually conveying one air-transportable unit or subunit to the same objective.

**Special Tactics Squadron**—AF special operations combat control and pararescue forces.

**Station Time (Air Force)**—A specified time at which aircrew, passengers, and material are to be in the aircraft and prepared for flight. Passengers will be seated and loads tied down. Aircrews will have completed briefing and aircraft preflight inspection prior to station time. Normally, station time will be 30 minutes prior to takeoff time.

**Station Time (Airborne)**—A specified time when parachutists will be seated in the aircraft with seat belts fastened. This time normally will be 5 minutes prior to Air Force station time.

**Supported Forces**—Space-required passengers consisting of US and foreign military members who are on board an MC-130J aircraft as an integral part of the mission being performed.

**Supporting Forces**—Space-required passengers consisting of US and foreign military members, DoD civilians, and US civilian employees under contract to the DoD, who directly support the mission or deployment of an AFSOC unit.

**Tilt-Rotor Air-to-Air Refueling (TAAR)**—Airborne fuel offload by MC-130 aircraft to a Tilt-Rotor receiver.

**Time Over Target (TOT)**—The actual time an aircraft is at a geographic point or area carrying out an assigned mission.

**Terminal Fuel Flow (TFF)**—Hourly fuel flow from the last applicable cruise leg on the CFP.

**Zero Fuel Weight (Actual)**—The actual zero fuel weight of an aircraft plus the weight of the cabin load (cargo, passengers, troops, and munitions).

**Zero Fuel Weight (Maximum)**—That weight expressed in pounds where an addition to the aircraft gross weight can be made only by adding fuel in wing tanks. This value is referred to as "Limiting Wing Fuel."



## Attachment 2

### INFILTRATION/EXFILTRATION PROCEDURES

#### A2.1. General Procedures.

A2.1.1. Infil/Exfil Procedures. Use this guidance when conducting infil/exfil operations. These procedures are only authorized when conducting infil/exfil operations with dedicated unconventional forces and foreign counterparts. All personnel in the cargo compartment will be seated and secured except those crew members having valid duties to perform. (T-2)

A2.1.1.1. Rapid Infiltration (“Rapids”). Rapids are a tactical method of onloading or offloading dedicated unconventional and Special Operations Forces. Spring-loaded, latch-activated, folding ramps (canary slides), or ground loading ramps are used to offload and onload vehicles, personnel, and H-6 series helicopters in minimal time. Selection of the onload/offload point and aircraft orientation impacts total ground times. Extensive premission planning/static load training may be required for large or complex loads. **Exception:** Group commander/COMAFSOF (for contingency operations) may authorize Rapid Infil/Exfil procedures and floor loading with non-SOF personnel to meet unit training requirements.

A2.1.2. Preparation. Prepare aircraft for Infil/Exfil IAW TO 1C-130(M)J-9.

A2.1.3. Loadmaster Preflight:

A2.1.3.1. Blackout covers should be in place for all missions flown in a hostile environment at night.

A2.1.3.2. Chemical lights will be attached to each emergency exit handle. Apply tape to allow a small amount of light to shine through. (T-2)

A2.1.3.3. Emergency exit lights will be armed/off (as required). (T-2)

A2.1.3.4. Cargo compartment lights will be set (as required). (T-2)

A2.1.3.5. Door warning lights will be taped (as required). (T-2)

A2.1.3.6. Turn off cargo floor, crew entrance door and nose gear inspection lights.

A2.1.3.7. Jump lights will be taped (as required). (T-2)

A2.1.4. Approved Deviations. Personnel inside vehicles will be properly secured either with vehicle seat belts or personnel restraining devices (e.g., Swiss Seats) for takeoffs and landings. (T-2) Do not exceed maximum vehicle gross weights. (T-2) All other personnel in the cargo compartment will be seated and secured using personnel restraint device or passenger combat loading procedures. (T-2) Crew members with valid duties (such as scanning) to perform are not required to be seated. (T-2) **Note:** Users will provide their own personal restraint device. If user does not provide their own restraining devices, secure personnel using passenger combat loading procedures. (T-2)

A2.1.4.1. Loadmasters. Loadmasters are normally positioned in the paratroop door and secured in a troop door seat or with a modified restraint belt or Swiss Seat for takeoff and landings when using infil/exfil procedures.



A2.1.4.2. Drivers. All vehicle drivers will wear NVGs when driving vehicles on or off the aircraft under blacked-out conditions or when cargo compartment EL/NVG lighting is in use. (T-2) If a vehicle driver does not have NVGs, the vehicle will be pushed or winched on/off the aircraft. (T-2)

A2.1.4.3. Aerial Delivery System (ADS). ADS arms will be disconnected/ disengaged at the 10-minute warning. (T-2) Reconnect/reengage ADS arms after takeoff as soon as mission requirements permit. (T-2) **Note:** If airdrop operations are to be conducted over the ramp after the ADS arms have been disconnected/disengaged, loadmasters will check the ramp/door in the ADS position (to facilitate checking the ADS/no-go light) prior to taking off/departure, if mission requirements allow . (T-2)

A2.1.4.4. Ramps. Canary slide ramps or auxiliary ground loading ramps may be installed in-flight and remain installed during all phases of flight. **Note:** It may be impossible to remove the auxiliary ground loading ramps from the outboard fittings with the ramp rails installed and the ramp on the ground. If this occurs, raise the ramp to horizontal to remove the loading ramps.

#### A2.1.5. Prohibited Actions.

A2.1.5.1. Open carriage vehicles such as: quads, mules (6-wheeler), motorcycles and mini-bikes will not allow drivers on vehicles for takeoffs and landings. (T-2)

A2.1.5.2. Personnel will not be inside helicopters for takeoff or landings. (T-2)

A2.1.5.3. For loads that have an item restrained to both the cargo floor and cargo ramp, open only the cargo door until the aircraft comes to a complete stop. The cargo ramp will not be lowered until the aircraft arrives at the offload point and all restraints are removed. (T-2)

A2.1.5.4. Vehicles will not be started in-flight. (T-2) **CAUTION:** To prevent the possibility of carburetor vapor-lock, vehicles will not be started in-flight. (T-2)

A2.1.5.5. The cargo ramp will not be lowered below horizontal until the aircraft comes to a complete stop at the offload point. (T-2)

A2.1.5.6. Vehicles will not be unloaded/offloaded while the center anchor cable supports are in the installed position. (T-2)

A2.1.5.7. Vehicle IR lights will not be used in or around aircraft. (T-2)

A2.1.5.8. Personnel will not loiter between vehicles while on the aircraft. (T-2)

A2.1.5.9. Personnel will not sit or extend arms or legs under vehicles. (T-2)

A2.1.5.10. Chemical lights attached to side escape hatch/crew entrance door handle will not be removed in-flight at any time. (T-2)

#### A2.1.6. Ordnance Procedures.

A2.1.6.1. 2.75-inch rockets and other missile-type arms may be taken out of shipping containers and shipping tubes. Safety rings must remain attached. (T-2) They may be secured in the vehicle for storage or maintained by the user.

A2.1.6.2. Machine gun/Gatling gun ammunition may be kept readily available but will not be breached (chambered) until exiting the aircraft. (T-2)

A2.1.6.3. Troops may maintain their own small arms ammunition, but weapons will not be breached (chambered) until exiting the aircraft. (T-2)

A2.1.6.4. All weapons will be cleared and on SAFE with muzzles pointing down prior to boarding the aircraft. (T-2)

#### A2.1.7. Fuel Limitations.

A2.1.7.1. Vehicle fuel tanks will not exceed 75% full when positioned on the cargo floor. Fuel tanks for vehicles transported on the cargo ramp will not exceed 50% full. (T-2)

A2.1.7.2. The H-6 series helicopters' main and auxiliary tanks will not exceed 75% full. (T-2)

A2.1.7.3. Spare gas cans (DOT 5L, jerry type) must have serviceable rubber gaskets in place and be secured inside the vehicle. (T-2) **Exception:** Some types of vehicles provide for the storage of spare fuel cans outside of the vehicle. They will be secured to prevent puncture in the event of contact with the aircraft or another vehicle. (T-2) In all cases, do not place fuel cans on the front or rear bumpers. Spare gas cans may be filled to their capacity. If placed on the aircraft floor, metal-to-metal contact is not allowed. (T-2) **Note:** Total combined fuel quantity for a vehicle and DOT 5L jerry cans cannot exceed twice the vehicle fuel tank capacity. (T-2)

A2.1.8. Aircraft Configuration. See AFMAN 11-2EC/MC-130J, Vol 3, and Addenda A as required. **Note:** Due to the unique requirements needed to perform infiltration/exfiltration procedures sound judgment and coordination with user personnel will dictate specific aircraft configuration beyond the basic aircraft configurations. Cargo ramp and minimum necessary canary slides/ground loading ramps should be left extended until the latest possible time to facilitate bump plans at the intermediate staging base (ISB).

#### A2.1.9. General Considerations.

A2.1.9.1. Tape chemical lights to emergency exit handles to allow a small amount of light to shine through. **WARNING:** Chemical lights attached to exit doors and emergency escape hatch handles will remain in place until mission completion. (T-2)

A2.1.9.2. Tape may be used on the cargo compartment floor and tie-down rings to mark vehicle locations and tie-down points for exfil operations. **Note:** Tape is usually installed at the ISB during static loading for exfil operations.

A2.1.9.3. Tying pairs of auxiliary ground loading ramps together with 1/2-inch tubular nylon or 550 cord can expedite closing operations.

A2.1.9.4. The following are considerations for H-6 series helicopters.

A2.1.9.4.1. Remove paratroop door jump platforms to prevent the tail/tail rotor from contacting them on rapid onload/offload operations.

A2.1.9.4.2. If dual rails are unable to be removed from the aircraft due to short notice tasking/mission requirements, up to three H-6 series helicopters may be loaded safely (if not equipped with modified tail boom). Extreme caution is needed during loading

to ensure the tail/tail rotor of the last aircraft will not contact the cargo door and ramp/canary slides or ground loading ramps when in the closed position. (T-2)

A2.1.9.4.3. Restraint Requirements. All vehicles/helicopters will be restrained IAW **Table A2.1**. (T-2)

**Table A2.1. Restraint Requirements.**

Weight of Vehicle (pounds)	Restraint Required
Less than 5,000	4 x 5,000-/10,000-pound straps (2 forward/2 aft)
5,001 to 7,500	6 x 5,000-pound straps (4 forward/2 aft) or 4 x 10,000-pound straps/chains and devices (2 forward/2 aft)
7,501 to 11,500	6 x 10,000-pound straps/chains and devices (4 forward/2 aft)
11,501 to 12,100	10 x 10,000-pound straps/chains and devices (6 forward/4 aft)
<b>Note:</b>	
The rapid all-terrain vehicle (RATV) will be restrained using a minimum of six 5,000/10,000 pound tie-down straps (four forward and two aft). The tie-down attachment points on the RATV are only rated at 5,000 pounds. (T-2)	

A2.1.9.5. Restrain motorcycles, quads, and mini-bikes with one 5,000 pound tie-down strap each. Restrain quads weighing more than 1,500 pounds with three 5,000 pound tie-down straps. (The vertical strap centered over the seat will be left on during taxi. The forward and aft straps may be removed after 80 knot call). (T-2)

A2.1.9.6. Motorcycle, quad and mini-bike restraint may be attached to a prepositioned chain connected to the aircraft sidewall tie-down rings.

A2.1.9.7. Restrain H-6 series helicopters with five 5,000 pound tie-down straps (two forward, two aft, and one tail boom, or as identified by the user). **Note:** 10,000 pound straps may be used in-lieu of the 5,000 pounds straps for H-6 series helicopters. Users will provide straps when the 10,000 pound strap is used. (T-2) **WARNING:** Chains positioned across side emergency exits will be connected to the sidewall tie-down ring with a tie-down device to expedite removal in case of emergency egress. (T-2)

A2.1.9.8. Leave approximately 24 inches of slack in the excess portion of the tie-down strap if possible. After the vehicle is restrained, the excess strap will be rolled and taped. (T-2) Do not tape the excess portion to the taut side of the strap. **Exception:** The 5,000 pound straps used to tie-down H-6 series helicopters will have slack folded and taped to the taut side of the strap with enough slack to allow removal/installation. (T-2)

A2.1.10. Static Load Training. Conduct static load training prior to all infil/exfil operations. Conduct static load training during daylight (or white lights), blacked-out, and high noise environments (e.g., APU, cheek rack blowers). For training, conduct static load training to your situation (e.g., day rapids only require day static load training). **Note:** Ensure vehicle and passenger configuration/load sequence is thoroughly validated by user and loadmaster.

A2.1.10.1. Generation IV ground loading ramps/bi-fold ramps (canary slides) will be used. (T-2) Canary slide ramps are primary for helicopter onload/offload but facilitate

on/offloading for all types of cargo. During helicopter onload use a full set of canary slides or five ground loading ramps if canary slides are not available. Five auxiliary ground loading ramps or three canary slide ramps will be used unless mission requirements allow fewer numbers to be used. (See TO 13C10-8-1, *Bi-Fold Auxiliary Ramp* for limitations and preflight inspection requirements.) (T-3)

A2.1.10.2. Install/stow ramps using a minimum of two people.

A2.1.10.3. Ramp intermediate roller conveyors should not be installed when canary slides are being used.

A2.1.10.4. Ensure canary slides do not contact the cargo door during opening or closing.

A2.1.10.5. The loadmaster will notify personnel at 60, 30, 20, 10, 6, 1 minute(s), and immediately prior to landing. (T-2) The 1 minute will be initiated when the CSO calls "2 MILES" or "EXPECT DESCENT IN 1 MILE." Give a "PREPARE TO LAND" call when the CSO calls "MINIMUMS" or "100 FEET ABOVE TOUCHDOWN." (See TO1C-130(M)J-1 for expanded Infil/Exfil Checklist.) (T-2)

#### A2.1.11. Aircraft Egress, Familiarization and Destruction Training.

A2.1.11.1. Aircraft egress, familiarization and destruction training will be conducted with the user participating in infil/exfil operations. (T-2) This training is mandatory for all personnel prior to the mission and will be conducted during static load training. (T-2) The aircraft loadmasters are responsible for conducting this training on their aircraft. (T-2) **Note:** In cases where the crew which performed static load/egress training does not fly the mission, another crew from the same MDS may execute the mission, provided a detailed face-to-face briefing is conducted prior to execution with the original crew and the user.

A2.1.11.2. Egress drills will be conducted during static load training. (T-2) They will be conducted during daylight (or white light) and blacked-out/minimum EL/NVG lighting conditions. (T-2)

A2.1.11.3. All user personnel will practice the use of emergency exits and equipment. (T-2) **CAUTION:** When demonstrating the use of overhead emergency exits, ensure user personnel are fully briefed on equipment that may be damaged during egress.

#### A2.1.12. Offload Operations.

A2.1.12.1. Vehicles will be backed onto the aircraft. (T-3) Park vehicles in lowest gear (neutral for diesel powered). Put automatic vehicles in park. (T-2)

A2.1.12.2. Loadmasters will pass time warnings/advisories to the troop commander/departure airfield controlling officer (DACO). (T-2)

A2.1.12.3. All personnel will prepare for landing at the 6-minute advisory. (T-2)

A2.1.12.4. A loadmaster will remain on headset at all times (normally the left side loadmaster). (T-2)

A2.1.12.5. Loadmasters will use NVGs for all infil/exfil operations. (T-2)

A2.1.12.6. Cargo compartment EL/NVG lighting will be adjusted to the minimum setting required at the 6-minute advisory. (T-2) Aircraft not equipped with EL/NVG lighting will turn the red lights off at the 6-minute advisory. (T-2) Do not turn off/readjust lights until

the troop commander/DACO confirms checks are complete. (T-2) **Note:** EL/NVG lighting may be adjusted to minimum setting prior to the 6-minute advisory, provided the user is notified.

A2.1.12.7. User personnel will initiate their “80-knot” procedures upon hearing the “80-KNOT” call or when the aircraft ramp and door start to open. (T-2)

A2.1.12.8. All restraint devices except one forward and one aft (opposite corners) may be removed during taxi to the offload point (one strap over seat for motorcycles, quads, and mini-bikes will remain installed). Self-propelled vehicles must have drivers in place with brakes set prior to removing restraints. (T-2) **Exception:** All restraints will remain on helicopters except for the tail boom until the aircraft has come to a complete stop. (T-2)

A2.1.12.9. Do not position the cargo ramp below horizontal until the aircraft comes to a complete stop at the offload point. For areas where ground threats or mission requirements dictate minimum time on the ground, the loadmaster and the AC will brief a countdown for movement of the ramp below horizontal. (T-3) Caution must be exercised to ensure the ramp does not contact the ground before the aircraft stops.

A2.1.12.10. Do not deploy canary slides/ground loading ramps until the ramp is positioned below horizontal and the aircraft has stopped.

A2.1.12.11. Clearance to offload: A loadmaster will be positioned on the vehicle driver’s side of the cargo ramp and raise both arms to signal clearance to offload. (T-2) The loadmaster will drop both arms to signal vehicle drivers to halt offload operations. (T-2)

A2.1.12.12. Offload vehicles and personnel as trained during statics.

A2.1.12.13. Clear a stalled vehicle immediately to the aircraft right (engines 3 and 4) or as static trained to allow the offload to continue. **Note:** If a time delay occurs before onloading/departure, turn off all EL/NVG lighting and raise the ramp approximately 12 inches to allow the aircraft to be taxied in the event of an emergency.

#### A2.1.13. Onload Operations.

A2.1.13.1. A loadmaster will remain on headset at all times (normally the left side loadmaster). (T-2)

A2.1.13.2. Loadmasters will use NVGs for all infil/exfil operations. (T-2)

A2.1.13.3. EL/NVG lighting will be adjusted as required for the onload. (T-2)

A2.1.13.4. A loadmaster will be positioned on the vehicle driver’s side of the cargo ramp. (T-2) The loadmaster will advise the troop commander/DACO when ready for loading. (T-2) The troop commander/DACO will not clear personnel or vehicles to load until cleared by the loadmaster. (T-2)

A2.1.13.5. A loadmaster will be in the cargo compartment to marshal vehicles into position with IR chem-lights. (T-2)

A2.1.13.6. Load vehicles and personnel as trained during statics.

A2.1.13.7. The loadmaster will coordinate with the troop commander/DACO to confirm all personnel and equipment are onboard and the onload is complete. (T-2)

A2.1.13.8. When the loadmaster has determined sufficient restraint has been applied to the load, (minimum of one forward and one aft) and it is safe to do so, the loadmaster will advise the crew "CLEAR TO TAXI." (T-2) Once the ramp and door are closed and locked, the cargo compartment EL/NVG lights may be turned to the maximum setting (if required). After all cargo and personnel restraint is checked, the loadmaster will advise the crew "SECURE." (T-2)

### Attachment 3

#### HOT REFUELING/FARP PROCEDURES

**A3.1. General.** This attachment provides Forward Area Refueling Point (FARP)/hot refueling guidance for MC-130J aircraft. The guidance in this attachment supplements the procedures outlined in TO 00-25-172, *Ground Servicing and Static Grounding/Bonding*, and AFI 11-235, *Specialized Fueling Operations*. A comprehensive mission briefing and strict compliance with these procedures will ensure an expeditious safe refueling operation. (T-2)

A3.1.1. FARP and Hot Refueling Equipment. Refueling aircraft while engines are running requires specific equipment and inspections prior to commencing operations. Only equipment approved IAW TO 00-25-172, TO 37A9-7-2-1, and in the System Safety Engineering Analysis (SSEA) shall be used. This equipment is unique in that it provides for an internal bond that is not provided for with conventional refueling equipment. If unapproved equipment is used, the refueling operation must be accomplished without engines running (cold refueling). See AFI 11-235 for required equipment for personnel that will have direct contact with fueling equipment during fueling operations.

A3.1.2. Weather Requirements. For training operations and exercises, stop fuel servicing when high winds or reduced visibility exists or when an electrical storm is within a five mile radius of the hot refueling site. For real world operations, consider the distance of the storm from the refueling site, direction it is traveling, and its intensity, and use good judgment to determine when to suspend fueling operations.

A3.1.3. Safety. Because of the inherent dangers with the ground refueling and rearming of aircraft, safety cannot be overemphasized. Safety is the responsibility of all personnel and is considered before, during, and after all refueling operations. Any person observing an unsafe situation, practice, or procedure should immediately inform all personnel, and all refueling and rearming operations will immediately stop until the unsafe condition can be eliminated.

A3.1.4. Fire Protection:

A3.1.4.1. Personnel involved in servicing operations will be trained in the use of portable fire extinguishers. (T-2)

A3.1.4.2. One Halon 1211 extinguisher positioned between the refueling equipment and the refueling supervisor's position. An ARFF vehicle will be on standby posture. (T-2) The Base Fire Chief determines positioning for optimum response.

A3.1.4.3. For exercises or contingencies where a crash fire vehicle cannot be provided, a minimum of one 20-pound dry chemical extinguisher will be positioned at the receiver Single Point Refueling (SPR) and the refueling source. (T-2)

A3.1.5. Heat exhaustion and carbon monoxide inhalation: Heat exhaustion and carbon monoxide inhalation, although not serious problems are two factors that can affect a crew's ability to perform at their peak. You can suffer heat exhaustion or minor burns from the heat of the engines combined with wind conditions. You may also inhale carbon monoxide from the engine exhausts. The following are suggestions of how to minimize the effects of heat and carbon monoxide if the tactical situation will permit:

A3.1.5.1. Keep drinking water available, and drink large quantities of water to help prevent dehydration.

A3.1.5.2. Raising the aircraft flaps may reduce the exhaust being placed on the loadmaster. Wind direction, temperature, location and environment are all factors to be considered.

A3.1.6. General Ordnance Procedures. Aircraft may be refueled with engines running with live ordnance aboard; however, upload/download of ordnance and refueling of aircraft will normally be conducted as separate operations; a separate area should be established at least 300 feet from the hot refueling site. (T-2) During combat or contingency operations, concurrent refueling and upload/download of ordnance may be authorized when, in the judgment of the mission commander, operational necessity and benefits of reducing ground time outweigh the risks involved.

A3.1.7. Electronic Emissions:

A3.1.7.1. Inertial navigational systems (INS or INU) may remain energized.

A3.1.7.2. Radar and ECM equipment will not be operated within the refueling area. (T-2)

A3.1.7.3. Any handheld radios used within the Fuel Servicing Safety Zone (FSSZ) must be intrinsically safe. (T-2)

A3.1.7.4. HF radio transmissions are not allowed within the FSSZ during refueling operations. (T-2)

A3.1.7.5. Internal Communications. During ground operations, communications can be difficult due to aircraft noise levels. Interphone discipline is essential so emergency calls may be relayed clearly. All unnecessary voice communication is prohibited for safety reasons. (T-2) Voice communication contact between the loadmaster and cockpit will be maintained at all times. The loadmaster does not have to maintain interphone contact while positioning/repositioning refueling equipment, but will be on interphone any time the refueling nozzle is connected to the aircraft. (T-2)

**A3.2. Hot Refueling.** For MC-130J aircrews, basic hot refueling is the transfer of fuel (refuel or defuel) at sites where all required equipment is provided at that site. MC-130J aircrews qualified in hot refueling may refuel/defuel at fixed-sites, refuel/defuel with approved fuel trucks and receive fuel from a fixed-wing tanker at FARP sites.

A3.2.1. Planning Factors: Planners must be aware of factors which limit hot refueling employment and should consider the following when including a hot refueling option in an exercise or contingency:

A3.2.1.1. Passengers. Personnel and equipment may be off-loaded or on-loaded in conjunction with refueling operations. Personnel movement on or off the aircraft should be monitored to maintain accountability in case of an emergency.

A3.2.1.2. Hot Refueling Sites. Depending on the sister service or host nation there can be several different types of hot refueling sites. Some of the different types of sites are as follows:



A3.2.1.2.1. Forward Area Refueling Equipment (FARE). FARE sites are normally setup by the Army using blivets to refuel aircraft. Hot refueling qualified crews may conduct refueling/defueling operation at these sites.

A3.2.1.2.2. Forward Area Refueling Point (FARP). FARP sites are normally established for aircraft to aircraft refueling. Hot refueling qualified crews may conduct receiver operations at these sites. **Note:** Refueling trucks may conduct refueling/defueling operations to a single aircraft at FARP sites.

A3.2.1.2.3. Hot Refueling Site. Hot refueling site is a generic term used for a site that refuels/defuels aircraft with engines running from a fixed source or a fuel truck. Hot refueling qualified crews may conduct operations at these sites. **Note:** All hot refueling sites will have a current site survey and meet the minimum unobstructed egress distance required by the survey to ensure the aircraft can taxi from the site in the event of an emergency. (T-2) If the egress distance is less than the required minimum or the egress area is obstructed, tanker/receiver aircraft will perform refueling/defueling in a cold environment only. (T-2)

A3.2.1.2.4. Planners must verify equipment at the intended hot refueling location is approved for use in hot refueling operations. (T-2) Refer to TO 00-25-172, TO 37A9-7-2-1, *Forward Area Manifold Cart*, and SSEA for approved equipment.

A3.2.2. Responsibilities. Only current and qualified crew members will be allowed to occupy a primary crew position on hot refueling missions. (T-2) **Note:** The pilot, copilot, and Combat Systems Operator (CSO) will remain on the flight deck in the event of an emergency taxi, i.e., moving the aircraft. (T-2)

A3.2.2.1. The Pilot in Command (PIC) is responsible for the overall safety of the crew and the aircraft hot refueling operations. The PIC relies on the Loadmaster to announce any unusual situations and to recommend the best course of action. The PIC ensures the crew is briefed IAW this manual prior to commencing hot refueling operations. The aircraft commander will: (T-2)

A3.2.2.1.1. Ensure approval has been granted by the proper authority prior to conducting hot refueling operations.

A3.2.2.1.2. Ensure all crew members are briefed on their specific responsibilities.

A3.2.2.1.3. Analyze runway availability prior to landing to determine braking action. Unnecessary or heavy braking could delay hot refueling operations.

A3.2.2.1.4. Analyze planned hot refueling area for hazards and sufficient taxi clearances.

A3.2.2.1.5. Determine fuel requirements to include estimated on-load and off-load.

A3.2.2.2. The CSO/Copilot (CP) will:

A3.2.2.2.1. Control fuel distribution and the SPR drain pump. (T-2)

A3.2.2.3. Loadmaster (LM). The LM is responsible for supervising fuel servicing operations. The loadmaster will:

A3.2.2.3.1. Ensure compliance with all safety procedures. (T-2)

A3.2.2.3.2. Immediately inform the pilot and advise the crew on recommended course of action, in the event of a hazardous situation/emergency. (T-2)

A3.2.2.3.3. Ensure all required equipment is onboard prior to and after hot refueling operations. (T-2)

A3.2.2.3.4. Operate the ramp and door or paratroop door as required.

A3.2.2.3.5. Complete the hot brake/hung flare check prior to commencing hot refueling operations. (T-2)

A3.2.2.3.6. Ensure that all personnel are properly briefed on fueling procedures.

A3.2.2.3.7. Perform leak check at SPR panel. (T-2)

A3.2.2.3.8. Secure aircraft for departure after all equipment and personnel are aboard.

A3.2.3. Emergency Procedures. Emergency procedures are published in the applicable checklist. They will be reviewed by all crew members and briefed by the PIC prior to commencing hot refueling operations. (T-2) All personnel, including ground controllers, will know the ground evacuation plans. (T-2) Stop all hot refueling operations immediately when a leak, unsafe condition or system malfunction occurs. Correct the deficiency before resuming hot refueling operations.

**A3.3. Forward Area Refueling Point (FARP).** FARP is a tactical aircraft-to-aircraft ground refueling operation primarily performed with engine's running. FARP operations are normally conducted by MC-130 and special operations forces (SOF) attached C-17 aircraft.

A3.3.1. Planning Factors: Planners must be aware of factors which limit FARP employment and should consider the following when including a FARP option in an exercise or contingency: (T-2)

A3.3.1.1. All FARP sites will have a current site survey and meet the minimum unobstructed egress distance required by the survey to ensure the aircraft can taxi from the site in the event of an emergency. (T-2) If the egress distance is less than the required minimum or the egress area is obstructed, tanker/receiver aircraft will perform refueling/defueling in a cold environment only. (T-2) **Note:** Refueling trucks may conduct refueling/defueling operations to a single aircraft at FARP sites.

A3.3.1.2. Ensure fire protection equipment is available IAW AFI 11-235 and meets the requirements of TO 00-25-172, Ground Servicing and Static Grounding/Bonding.

A3.3.1.3. Ensure all AF personnel involved are trained IAW appropriate command directives.

A3.3.1.4. Passengers. Personnel and equipment may be off-loaded or on-loaded in conjunction with refueling operations. Personnel movement on or off the aircraft should be monitored to maintain accountability in case of an emergency.

A3.3.1.5. Rotate the Hot Refueling Supervisor (HRS) and Panel Operator (PO) positions approximately every 30 minutes as needed to minimize the PO exposure to carbon monoxide.

A3.3.2. Responsibilities. Only current and qualified crew members will be allowed to occupy a primary crew position on hot refueling missions. (T-2)

A3.3.2.1. Hose deployment personnel - one per refueling point, and one (if available) to operate the Forward Area Manifold (FAM) cart. **Note:** The pilot, copilot, and CSO will remain on the flight deck in the event of an emergency taxi, i.e., moving the aircraft. (T-2)

A3.3.2.2. The PIC is responsible for the overall safety of the crew and the aircraft hot refueling operations. The PIC relies on the Loadmaster to announce any unusual situations and to recommend the best course of action. The PIC ensures the crew is briefed IAW this manual prior to commencing FARP operations. The aircraft commander will:

A3.3.2.2.1. Ensure approval has been granted by the proper authority prior to conducting FARP operations.

A3.3.2.2.2. Ensure all crew members are briefed on their specific responsibilities.

A3.3.2.2.3. Analyze runway availability prior to landing to determine braking action. Unnecessary or heavy braking could delay FARP operations.

A3.3.2.2.4. Analyze planned FARP area for hazards and sufficient taxi clearances.

A3.3.2.2.5. Determine fuel requirements to include estimated on-load and off-load.

A3.3.2.3. The CSO/CP will:

A3.3.2.3.1. Control fuel distribution and the SPR drain pump.

A3.3.2.4. HRS. The HRS is responsible for supervising fuel servicing operations and ensures that all personnel are properly briefed on fueling procedures.

A3.3.2.4.1. The HRS will monitor the positioning and layout of hoses and equipment. (T-2) After the equipment is deployed, the HRS will direct FARP operations. (T-2)

A3.3.2.4.2. The HRS instructs the PO/CSO when to dispense or shutoff fuel flow by interphone or hand signals, monitors for fuel leaks and periodically scans the tanker wings. The HRS will be positioned so as to have an unobstructed view of the entire operation. (T-2)

A3.3.2.4.3. In the event of a hazardous situation/emergency, the HRS will immediately inform the pilot and advise the crew on recommended course of action. (T-2)

A3.3.2.4.4. When the FARP is complete, the HRS assists the Hose Deployment Personnel (HDPs) with the tear down of the FARP site and PO assumes primary interphone contact.

A3.3.2.5. Panel Operator (PO). The PO operates the Rapid Ground refueling (RGR)/SPR panel.

A3.3.2.5.1. The PO deploys the tanker end of the refueling hose and connects the nozzle to the RGR/SPR receptacle IAW applicable directives.

A3.3.2.5.2. The PO will perform a leak check at the RGR/SPR panel. (T-2)

A3.3.2.5.3. **Note:** The HRS, PO and HDP at each refueling point will perform an on-scene inspection of the pressurized system for leaks, slippage of fuel hoses from hose couplings and general condition of hoses. Hoses that leak or have blistering, saturation

or cuts/abrasions which expose the reinforcement material shall be removed from service.

A3.3.2.5.4. Once hose layout is complete, the PO will position the fire extinguisher and water container in a readily accessible location near the aircraft. (T-2)

A3.3.2.5.5. The PO assumes primary interphone contact when the HRS assists the HDPs in evacuating hoses/tear down.

A3.3.2.5.6. Secure aircraft for departure after all equipment and personnel are aboard.

A3.3.2.6. Hose Deployment Personnel (HDP). AF fuels personnel (AFSC 2F0X1) will be included in the FARP crew and will deploy/redeploy fuel hoses. Minimum HDPs will be one person for each receiver point. (T-2) The personnel designated as HDPs will deploy hoses from the aircraft and set up the refueling points. (T-2)

A3.3.3. FARP Equipment. The FARP mission requires specific equipment and inspections prior to commencing operations. Only equipment approved IAW TO 00-25-172, TO 37A9-7-2-1, and in the SSEA shall be used. (T-2) This equipment is unique in that it provides for an internal bond that is not provided for with conventional refueling equipment. If unapproved equipment is used, the refueling operation must be accomplished without engines running (cold refueling). (T-2)

A3.3.3.1. Unisex Couplings. Each coupler has a two-position handle for Flow or No Flow. Connection and disconnection are only possible when the handles of both couplers are in the No Flow position. In the No Flow position, the internal ball valve is locked close to prevent fuel spillage. Approximately 15cc of fuel may spill when disconnecting the coupler assembly. The Unisex coupling provides the following unique features:

A3.3.3.1.1. Provides fuel shut off and disconnects with dry break capability at each coupling.

A3.3.3.1.2. Eliminates the concern for male/female connection relationship of FARP components.

A3.3.3.1.3. Fuel spillage during set up and take down of equipment is minimized to less than 15cc fluid loss when couplings are disconnected.

A3.3.3.1.4. The couplings cannot be connected or disconnected while either valve is open. Handle dual safety lock prevents inadvertent valve opening while disconnected and pressurized.

A3.3.3.1.5. Valve design provides straight through flow for maximum flow rate with minimal pressure loss. Valves can be opened with full line pressure when connected. Valves can be shut off while the system is pressurized should it be necessary to isolate or bypass any section of the FARP.

A3.3.3.1.6. Dust caps provide a seal against dust and dirt when installed. Common face seal used on caps may be used as a spare should coupling seal become damaged. Caps will be connected together for seal and dirt protection when not connected to coupling.

A3.3.3.1.7. **Note:** The dust cap seal and coupling seal have a tendency to stick together. When removing dust cap, check that only one seal is installed in coupling. Failure to adhere to this note will make other connections difficult or impossible.

A3.3.3.1.8. Electrical conductivity is provided throughout the connected system.

A3.3.3.2. Fueling Hose. The hose is a lay-flat, lightweight, continuous length, flexible design with an abrasive resistant sheath cover. The hose features a khaki green color polyurethane elastomer tube. The textile reinforcement contains 4 continuous length copper wires to provide an electrical bond between the hose and end couplings. The abrasion resistant outer sheath is woven from polyester and is coated with black polyurethane to increase abrasion resistance and provide the required flat black color. Operating pressure for the hose is 300 psi with a burst pressure of 600 psi. Hoses that have been recoupled must maintain 90 percent of original length.

A3.3.3.3. **Note:** Avoid crimping a pressurized hose and dragging it on the crimped end. This will cause damage to the hose.

A3.3.3.3.1. Kinks and short loops in refueling hose shall be avoided.

A3.3.3.3.2. Do not drag fuel nozzles and hose couplers along the ground unnecessarily.

A3.3.3.3.3. **Note:** Each continuous length hose assembly has a Unisex ball coupler. Hoses can be connected to nozzles and hose reels by aligning the coupler lugs and rotating. Dust caps are supplied and must be connected together to prevent contamination.

A3.3.3.3.4. **Note:** Hoses that have abrasion through the sheath (detected by seeing the khaki green underlying hose) will be repaired by replacing the sheath. (T-2) Hoses that have been cut and re-coupled must maintain 90 percent of original length. (T-2)

A3.3.3.3.5. **Note:** The dust cap seal and coupling seal have a tendency to stick together. When removing dust cap, check that only one seal is installed in coupling. Failure to adhere to this note will make other connections difficult or impossible.

A3.3.3.4. Unisex Fittings. The “T”, “X” and “Y” fittings are used for connecting hoses together and directing fuel flow. Each fitting has a coupling with a two position handle for flow/no flow. Connect/disconnect is possible only when the handles of both coupling halves are in the no flow position. In the no flow position, the internal ball valve is locked closed to prevent fuel spillage. An interlock pm locks the coupling halves together to prevent accidental disconnect and fuel spillage. No more than 15cc of fuel will spill when disconnecting these items. Each coupling has identical manually operated ball valves on each end of the assembly. Coupling assemblies are connected by aligning lugs and rotating. Dust caps will be attached and in place when hose assembly is stored. Ensure face seals are in place and undamaged. Spare face seals are carried on the face of the dust cover.

A3.3.3.5. The Single Point Refueling (SPR) nozzle. The SPR nozzle provides a leak tight connection for aircraft fueling. Nozzles that are attached to the tanker aircraft will have a 60-mesh strainer. This is the only means of filtering out solid particles of contamination before they reach the receiver aircraft. If the nozzle is to be used as a tanker nozzle, remove the strainer. This reduces the pressure drop and prevents contamination from collecting

outside on the strainer element and inadvertently being pumped into a receiver aircraft at a later date.

A3.3.3.5.1. To connect the nozzle to the aircraft receptacle remove the dust cap from the nozzle face, connect the nozzle to the adapter and turn clockwise. Turn the nozzle handle to the FLOW position. To disconnect the nozzle, turn the handle to the NO FLOW position, turn the nozzle counterclockwise and remove it from the adapter. Place the dust cap on the nozzle face down to secure it to the nozzle. Nozzle bonding plugs will be connected to bonding receptacles prior to connecting/inserting the nozzle to receiver aircraft.

A3.3.3.5.2. Always bond the nozzle to the aircraft before the fill cap is removed. This connection should remain in place until after the cap is replaced. Failure to perform this procedure can cause a static spark at the tank fill opening.

A3.3.3.5.3. **Note:** Prior to applying fuel pressure to the system, ensure the nozzle is securely locked by manually attempting to remove the nozzle with the valve in the open position. If the nozzle can be removed, it is defective and must be removed from service. (T-2)

A3.3.3.6. Open Port/Over Wing Nozzle. The over wing nozzle contains a 60 mesh strainer and an automatic shutoff feature. It is regulated to 25 PSI maximum (20 Gallons per Minute max output). Remove dust cap and lift handle to dispense fuel. Automatic shutoff feature must be tested prior to deployment by partially filling a grounded drip pan with the nozzle immersed in fuel. The automatic shut-off device should stop fuel flow. If shutoff feature fails, nozzle will be removed from service.

A3.3.3.7. External Drain Pump. This pump has a 28 volt DC 1/2 HP electric motor and is used for defueling the last 200 feet of hose by pumping the fuel from the hoses into the tanker aircraft.

A3.3.3.8. Squeegees. Squeegees are used to ensure all residual fuel is removed from the hose. Squeegees should be used to evacuate fuel from the hose. The squeegee consists of two rollers attached to a three foot handle. It is manually pulled along the length of the hose. When squeegees are not available, walking and rolling the hose will suffice as an alternate method of draining. This alternate method will leave more residual fuel in the hose.

A3.3.3.9. Fire Extinguisher. A 20 lb dry chemical fire extinguisher will be placed near each tanker and receiver refueling point. (T-2) An infrared chemlight will be placed on each receiver water container indicating that the refueling point is ready for operation. (T-2)

A3.3.3.10. Water Container. A 5 gallon water container will be placed near each tanker and receiver refueling point. (T-2)

#### A3.3.4. Equipment Maintenance.

A3.3.4.1. Hydrostatic Testing. FARP hoses will be hydrostatic tested upon receipt, annually and after any hose repair or coupler replacement. (T-2) The entire system, (hoses, couplers, etc.) is connected to a hydrostatic hose tester, and pressurized to 75 PSI. Operating pressure for the hose is 300 PSI and burst pressure is 600 PSI.

A3.3.4.2. Hose Maintenance. Defective fuel hoses may have 10 percent of a hose length removed without replacing it with a new hose. Defective hoses that are less than 90 percent of original length will be removed from service. (T-2)

A3.3.4.3. Ohms Check. The FARP equipment bonds the tanker and receiver aircraft. Bonding is accomplished by internal conductors within the hoses. The ohms (resistance) check is critical as the equipment provides the only means of bonding between the tanker aircraft and the receiver aircraft. An ohms check will be performed on each hose using a multi-meter prior to each FARP mission and each time the equipment is reconfigured during that mission. (T-2) **Exception:** when nozzles or hoses are changed out during the actual FARP operation.

A3.3.4.3.1. Total resistance values will be as follows:

A3.3.4.3.2. The maximum allowable resistance for a 100-foot hose with couplers is 100 ohms.

A3.3.4.3.3. The maximum allowable resistance for a 200-foot hose with couplers is 200 ohms.

A3.3.4.3.4. The maximum allowable resistance for a 240-foot hose with couplers is 240 ohms.

#### A3.3.5. Hose Deployment from Aircraft Floor/Ramp.

A3.3.5.1. When deploying a three point system, the center point proceeds directly aft from the aircraft. Left and right points angle 45 degrees from center.

A3.3.5.1.1. Refueling hoses should only be pulled from over the shoulder while walking forward, not backwards.

A3.3.5.1.2. Depending on terrain features/obstacles, personnel may not be able to deploy hoses 45 degrees from center. This may not be identified during the crew briefing; however, in the event this cannot be accomplished proceed directly aft of the aircraft and turn left or right when obstructions permit.

A3.3.5.1.3. While deploying hoses, after sufficient resistance is met, lay down hoses and return to the aircraft for another length. Repeat this step as necessary until positioning is complete. Minimize the dragging of connections/valves to prevent damage.

A3.3.5.2. After positioning the hoses the full distance, the nozzle end is brought back approximately 25 feet (50 feet when refueling fixed-wing aircraft). HDPs will walk the length of the hoses back to the aircraft checking for kinks, twists, and dry break positions. (T-2)

A3.3.5.3. After HDPs have finished walking the hoses, they will notify the HRS with a thumbs up signal that the line check is complete. (T-2) HDPs will return to the aircraft for the fire extinguishers and water containers and return to the "X" fitting. (T-2) He will then wait for fuel pressurization to the points. (T-2)

A3.3.5.4. After the hoses are pressurized, the HDPs will perform a leak check taking the water bottle and fire extinguisher along. (T-2) When the leak check is complete, the fire extinguisher and water container is positioned alongside the refueling nozzle at the

refueling point. The HDP will place an infrared chemlight on the fire extinguisher, then kneel indicating the point is ready for operation. (T-2)

A3.3.5.5. **Note:** If the point becomes non-operational, remove the chemlight from the fire extinguisher.

A3.3.5.6. HDPs will remain at the refueling point to act as fire guard after passing the refueling nozzle to the receiver crew member. (T-2)

A3.3.5.6.1. Bonding will be accomplished by inserting the bonding plug from the refueling nozzle into the aircraft's external receptacle prior to any other action. (T-2) Once the bond has been made, the HDP will not place the hose on the ground or touch the receiver aircraft until the bonding wire is removed. (T-2)

A3.3.5.7. After the final receiver is fueled, the HDPs will position themselves at each refueling point to drain the hose. (T-2) Stretch hoses to their full length, starting at the SPR/CCR nozzle, and attach the squeegee to drain that segment of hose. After running the squeegee over the length of hose and reaching a connection, close both sides of the valve and disconnect hose. Install dust caps. Roll that segment of hose. Repeat steps for each section of hose. Return hoses to the aircraft floor.

A3.3.5.7.1. Squeegees should be used to drain hoses. When squeegees are not available, walking and rolling the hoses will suffice as an alternate method of draining. This alternate method will leave more residual fuel in the hoses and will increase tear down time. When reaching the fittings, raise the hose and let fuel drain from the fitting into the next hose, close both valves while in raised position. When reaching the cross connection, only close the valve that is designated for the hose you evacuated.

A3.3.6. Emergency Procedures. Emergency procedures are published in the applicable checklist. They will be reviewed by all crew members and briefed to the crew by the HRS/PO prior to commencing FARP operations. (T-2) All personnel, including ground controllers, will know the ground evacuation plans. (T-2) Stop all FARP and hot refueling operations immediately when a leak, unsafe condition or system malfunction occurs.



## Attachment 4

### COMBAT OFFLOAD PROCEDURES

**A4.1. General Procedures.** The method of combat offload will be determined by the aircrew based on the conditions at the offload site. (T-2)

**A4.2. Procedures.** Cargo pallets, airdrop platforms and CDS containers can be offloaded without damage to the aircraft with the cargo ramp in the horizontal position. Use the following methods for combat offload operations.

A4.2.1. Method A. Use this method to offload single, multiple, ramp or married pallets, airdrop platforms and CDS containers. Pallets, platforms or CDS may be offloaded in a train like fashion or one-by-one as the situation dictates. **Note:** When quickly offloading fragile items (such as computers), loadmasters may install ground loading ramps and lower the ramp to a position approximately 18 inches above the ground to lessen the chances of damage. As a technique, loadmasters can restrain the load with a drift strap while the pilot slowly taxis from underneath the load. **WARNING:** Many explosive items have specific "drop" criteria that, if exceeded, render the item useless or dangerous to the user. With the exception of small arms ammunition (hazard class and division 1.4), explosives and munitions shall not be combat offloaded without approval of MAJCOM/A3. **Exception:** Explosives and munitions rigged for airdrop may be combat offloaded without MAJCOM/A3 approval. **CAUTION:** A taxiway or ramp at least 500 feet long is required; however, 1,000 feet is desired to provide a margin of safety. When pallets, platforms or containers are offloaded one at a time, use a longer taxiway based on the number to be offloaded.

A4.2.1.1. Single or double/triple married pallets may be offloaded, without ballast, using this method provided their weight does not exceed 12,000 pounds, and the height of the pallets fall within cargo height jettison limit in section III of the flight manual or **Chapter 5** of the cargo loading manual.

A4.2.1.2. Airdrop rigged platforms up to 24 feet in length may be offloaded, without ballast, using this method provided their weight does not exceed 12,000 pounds. **Note:** Single or married pallets and airdrop rigged platforms over 12,000 pounds may be offloaded using this method, provided ballast or cargo equal to the difference between 12,000 pounds and the weight of the pallets or platforms (to be offloaded) remains in C through F compartments during offload. **EXAMPLE:** A 17,000 pound married pallet or airdrop platform requires 5,000 pounds of ballast or cargo to remain in C through F compartments during the offload.

A4.2.1.3. CDS bundles may be combat offloaded using this method. The static line retriever will be used via manual activation; manual gate cut may be done if the retriever is inoperative. (T-2) With the Centerline Vertical Restraint (CVR), offload must be accomplished one side at a time if the total bundle weight exceeds 12,000 pounds. Non-CVR single stick may be offloaded if the total weight is less than 12,000 pounds. Without the CVR, if the total weight of the bundles exceeds 12,000 pounds, bundles should be restrained in groups of four or less and offloaded one group at a time. For the unplanned combat offload of non-CVR bundles, restrain the bundles as described above. Perform an initial offload via the static line retriever, and on sequential off-load remove aft restraint before clearing the pilot to taxi. Consider the slope of the offload site, which may cause

bundles to roll aft upon removal of restraint. (T-2) **CAUTION:** When using method "A" on excessively rough, sharply undulating, or battle-damaged surfaces, damage to the aircraft ramp may occur. Reducing forward taxi speed on these surfaces will reduce aircraft oscillation. The PIC must determine if the offload area will permit the offload operation to be conducted without damage to the aircraft or equipment. (T-2)

A4.2.2. Method B. Use this method to offload married pallets that do not fit the category for method A or for which no ballast is available for married pallets weighing between 12,000 to 15,000 pounds. Use four serviceable steel 55-gallon drums under each pallet to be offloaded. The correct number of steel drums needed to complete this type of offload must be available at the offload site or must accompany the load when conditions at the offload site are unknown. (T2) **WARNING:** The maximum weight for pallets to be offloaded across the ramp at any one time when using method B is 15,000 lbs. **WARNING:** Do not use method B for airdrop-rigged platforms to prevent binding the platform under the vertical restraint rails.

A4.2.3. Method C. Use this method to offload additional options to download palletized cargo when MHE is not available, when other Combat Offload methods are not possible due to their requirements (i.e., ramp/taxiway space), or when cargo requirements dictate. This procedure is not to be confused with Method "A" procedures. Unlike Method "A" procedures, this method's process is: stop, lower the ramp, download, raise the ramp, taxi forward (approximately 88-inches), stop and repeat the process for each pallet to be downloaded. MC-130J P/CP will use existing Combat Offload checklists. (T-2) MC-130J Loadmasters will use attached checklists. (T-2)

A4.2.3.1. Once the aircraft is positioned and stopped at the offload site, Loadmasters will place the ramp on the ground and install the ground loading ramps. (T-2) Make sure to install the ground loading ramps at an equal distance from BL 0. Dunnage will be used for the first pallet to be offloaded. See [Figure A4.1](#), [Figure A4.2](#) and [Figure A4.3](#) for the three authorized ground loading ramp and dunnage configurations. If dunnage is not available, use an "anti-tip strap."

A4.2.3.2. Once the ramp is preloaded and the ground loading ramps are in place, Loadmasters will place a piece of dunnage on the outboard side of each ground loading ramp, unless otherwise noted. (T-2) The dunnage will overlap the ground loading ramp by at least 24-inches. (T-2) Once the dunnage and/or anti-tip strap is in place, remove the vertical restraint and the locks of the pallet to be offloaded then slowly push aft to the ramp crest. Once over the ramp crest, stay clear of the pallet and drift strap then allow to gravity extract. If the anti-tip strap is taut, it may be necessary to cut the anti-tip strap, otherwise remove the strap and proceed. After downloading the first pallet, raise the ramp approximately 2-inches above the ground and taxi forward, leaving enough room for the next pallet to be offloaded, then repeat the process. Dunnage and/or anti-tip straps are not required for remaining pallets at the same offload site.

A4.2.3.3. **Note:** When dunnage is not available for the first pallet to be offloaded, Loadmasters will use an "anti-tip strap". (T-2) To make an "anti-tip strap", use a length of 1-inch tubular nylon. Make a 6-inch loop on each end so that the overall length from loop to loop is 330-inches. Attach a carabineer to each loop. Attach one carabineer to the dual rail tiedown ring at F.S. 617 and attach the other carabineer to a tiedown ring on the pallet. Drift-straps will not be used with this method. (T-2)

Figure A4.1. Side View (1 of 2).



Figure A4.2. Side View (2 of 2).



**Figure A4.3. Aft View.**

A4.2.3.4. Cargo to be offloaded using Method "C" procedures must meet the below criteria:

A4.2.3.4.1. One 463L pallet (88" x 108") will be offloaded at a time.

A4.2.3.4.2. Pallets are limited to 90" vertical height and 8,500 pounds.

A4.2.3.4.3. Airdrop platforms/CDS will not be offloaded using this procedure. (T-2)

#### A4.2.4. Aircrew Procedures:

A4.2.4.1. Prior to commencing combat offload operations, the pilot will brief each crew member on the method to be used. (T-2) Specific procedures are in the expanded checklist. (T-2)

A4.2.4.2. All crew members participating in the offload will refer to the checklist. Report any problem to the pilot immediately. (T-2)

A4.2.4.3. If other individuals must be aboard to assist the crew in an unusual circumstance, give them a thorough safety and procedures briefing for the entire offload sequence. (T-2)

A4.2.4.4. The loadmaster will maintain constant interphone contact with the PIC and is the only crew member authorized to operate the dual rail locks during combat offload operations. (T-2) **WARNING:** During the entire offload operation, no one is permitted behind or beside the load unless the loadmaster checks that all rail locks are locked and engaged in the pallet detents or secures each pallet to aircraft tie-down rings to ensure positive aft restraint.

**Figure A4.4. Combat Offload Method C Checklist (1 of 2).**

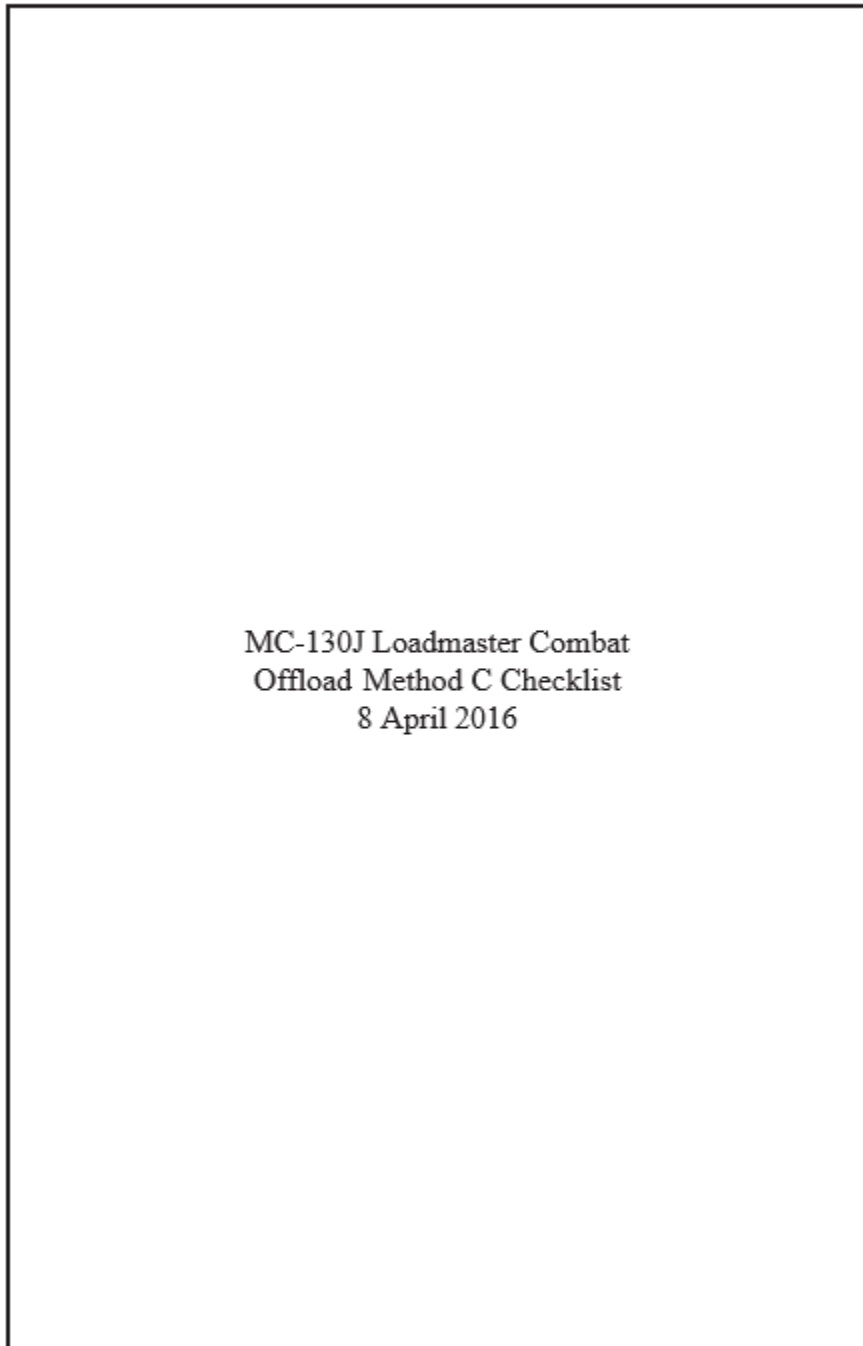

MC-130J Loadmaster Combat  
Offload Method C Checklist  
8 April 2016

Figure A4.5. Combat Offload Method C Checklist (2 of 2).

MC-130J Loadmaster Combat Offload Method C 8 Apr 16

**Combat Offload Method C**

1. ADS Latch Handles – Disengaged
2. Ramp – Lowered
3. Ground Loading Ramps – Installed
4. Dunnage Positioned
5. Area aft of aircraft – Clear
6. Locks – Unlocked
7. Pallets – Offloaded
8. Ramp – Readjusted
9. Notify Pilot – “Clear to taxi” (LM)
10. Notify Pilot – “Stop taxi” (LM)

**Note:** Repeat steps 6-10 for remaining pallets.

11. CNI-MU PAYLOAD – Adjusted (as required)
12. Ramp and door – Closed and locked
13. ADS arms – Reengaged
14. Offload Checks – “Complete”

Re-enter the INFIL/EXFIL On the Runway Checklist at step 7.

**Attachment 5**  
**BRIEFING GUIDE**

**A5.1. General.** MC-130J Briefing Guides are posted in unit In-Flight Guides.

**Figure A5.1. (Sheet 1 of 20) .**

<b>MC-130J AFSOC BRIEFING GUIDE</b>	
This briefing guide is a quick reference guide for Tactical Mission sorties. Expanded briefing items are included in the appropriate Technical Order. Units may locally reproduce this guide double sided on card stock to provide a more durable product for the checklist binder inserts.	
<b>TABLE OF CONTENTS:</b>	
AIRCREW MISSION BRIEFING	2
AIRDROP BRIEFING	6
HAAR/TAAR BRIEFING	8
SELF-CONTAINED APPROACH BRIEFING	10
AAR BRIEFING	12
PILOT-LOADMASTER/JUMPMaster/TROOP COMMANDER BRIEFING	13
CSO MISSION BRIEFING	16
FORMATION BRIEFING	18
DAY PRIOR ROUTE STUDY	20



Figure A5.2. (Sheet 2 of 20) .

2
<b><u>AIRCREW MISSION BRIEFING</u></b>
1. Roll Call
2. Time Hack
3. Mission Classification
4. Weather
a. Departure, en route, objective, recovery/alternates
b. Sun/moon rise/set, illumination, azimuth
c. Space weather products/effects on communications
d. BASH/BAM
5. NOTAMs
6. Intelligence
a. Bullseye
b. Prebriefed Threats
c. Aircraft Defensive Systems
(1) Type Load (Flares or Chaff)
(2) Settings
(3) Arming Procedures/ROE
d. Threat Reactions
(1) Terminology for Threat Advisories
(2) Reactions to Threat Advisory Calls
(3) Command/Control
7. Mission purpose
8. Mission description
a. Sequence of Events

Figure A5.3. (Sheet 3 of 20) .

	3
<b><u>AIRCREW MISSION BRIEFING (Continued)</u></b>	
9. Participating units	
a. Specific roles of units	
10. Aircraft status and location	
11. Load information	
a. Configuration	
b. Type load	
c. Load time	
12. Taxi and Prop Overspeed Governor Test	
13. Simulated Emergencies	
14. Ground/In-Flight emergencies	
a. Emergency ground egress	
b. Crash landing/ditching	
15. Crew Coordination	
a. Two Challenge/Time Out / Knock It Off	
b. Head-down/Head-up	
c. Transfer of Aircraft Control	
d. Time Nav – Lateral/Vertical/TOT	
e. Nav System Checks – within 10 mins	
f. Use of RADAR	
(1) GND MAP – OAPs	
(2) WX	
g. TAC Plots	
h. Off Course Maneuvering	

Figure A5.4. (Sheet 4 of 20) .

4
<b><u>AIRCREW MISSION BRIEFING (Continued)</u></b>
i. POS Alert Settings - .03/.05
16. Communications
a. Security
b. Authentication
c. IFF/SIF
17. Frequencies and call signs
a. Start/taxi/takeoff
b. En route
c. Objective areas
d. Recovery
e. Rescue (escape and evasion)
f. Command and control
g. Escorts
18. Mission Events
a. Airdrop (See Pg 6)
b. HAAR/TAAR (See Pg 8)
c. SCA (See Pg 10)
d. AAR (See Pg 11)
e. Pilot-Loadmaster/Jumpmaster (See Pg 12)
f. FARP
19. ORM Worksheet / SII / FCIF
20. Personal Equipment / Rings / Dog Tags / ID Cards

Figure A5.5. (Sheet 5 of 20) .

5
<b><u>AIRCREW MISSION BRIEFING (Continued)</u></b>
21. Mission summary
a. Stations time
b. Departure time
c. Aborts
d. Times for AC/LM/JM/Troop CC briefings
e. After landing procedures
f. Flying safety
g. Questions
h. Commander's comments

Figure A5.6. (Sheet 6 of 20) .

6			
<b><u>AIRDROP BRIEFING</u></b>			
1. Airdrop			
a. Type of Drop			
<b>Chute Type Exit Times.</b>			
<b>Extraction Chute Type</b>	<b>Exit Time</b>	<b>Extraction Chute Type</b>	<b>Exit Time</b>
Non-Towplate (All Chutes)	5.0 sec	Towplate (15' Chute)	2.7 sec
Towplate (22' Chute)	3.5 sec	Towplate (28' Chute)	3.4 sec
Towplate (2x28' Chutes)	3.2 sec		
b. TOT/TOA c. Opening ramp and door/paratroop doors d. Slowdown Type e. CARP/HARP location (if required) f. DZ identification g. Altitude/Airspeed/Heading h. Forecast winds/sea state/drop limits i. Jumpmaster directed airdrop procedures j. HALO/HAHO			
2. Use of checklists			
3. Load Info			
a. Weight			
b. Chutes			
c. FS Position			

Figure A5.7. (Sheet 7 of 20) .

7
<b><u>AIRDROP BRIEFING (Continued)</u></b>
d. Hazardous Materials / Nonstandard Loads
4. Formation procedures (if applicable)
5. Communication assignments
6. PF/PM/CSO duties
7. Use of Automation
8. Drop MSL altitude, and airspeed review
9. Use of jump lights/ADS button
10. Automatic or Manual release at CARP/HARP
11. Discontinuing a drop in progress
12. No-drop parameters
13. No-drop procedures/multiple passes
a. Crew acknowledgment
b. OVERRIDE/MANUAL selection
14. Defensive System Settings
15. Objective Area Considerations (LMP/NMP)
16. Escape
17. Emergency airdrop procedures
a. Salvo racetrack direction
b. Specific crew emergency actions

Figure A5.8. (Sheet 8 of 20) .

8
<b><u>HAAR/TAAR BRIEFING</u></b>
1. Receiver call sign/Type/Number
2. Refueling track/Direction
3. Type rendezvous
4. ARCT
5. Altitudes
a. Joinup
b. Refueling
c. MSA
6. Communications:
a. Deviation calls
b. Radar contact and contact lost calls
c. Range and bearing calls
d. Threat calls
e. Clearance to move hoses (silent vs. pilot's command)
f. EMCON
7. Radio configuration
a. Frequencies
b. Secure vs. plain
c. TACAN (Air-to-Air)
8. Altimeter setting
9. Hose configuration (Single vs. Dual) / Drogue Configuration
10. Simultaneous operations
11. Offload

Figure A5.9. (Sheet 9 of 20) .

	9
<b><u>HAAR/TAAR BRIEFING (Continued)</u></b>	
12. Crew Coordination	
a. Waypoint Sequencing – AUTO/MAN	
b. CNI-MU POD Control Page – PM	
c. Use of Automation	
13. Bingo fuel	
14. Divert base	
15. External lighting	
16. Missed rendezvous procedures	
a. Contact lost	
b. No visual contact	
c. Lost visual contact	
17. Door configuration	
18. Defensive System Settings	
19. Objective Area Considerations	
20. Emergency Procedures	



Figure A5.10. (Sheet 10 of 20) .

10
<b><u>SELF-CONTAINED APPROACH BRIEFING</u></b>
1. Use of checklist: <ul style="list-style-type: none"><li>a. NVG or non-NVG procedures</li><li>b. TOLD</li><li>c. Type landing/flap setting/bleed air</li></ul>
2. Formation procedures (if applicable)
3. Communication assignments
4. Runway/LZ <ul style="list-style-type: none"><li>a. Surface, markings, lighting</li></ul>
5. Crew member responsibilities
6. Slowdown Type / Location
7. Airspeed and MDA review
8. Exterior and interior lighting
9. Defensive System Settings
10. Objective Area Considerations
11. Go-around procedures
12. Ground operations <ul style="list-style-type: none"><li>a. Use of ramp and door</li><li>b. Taxi / Parking / MOG</li><li>c. Off/onload requirements</li><li>d. FARP briefing update</li></ul>
13. Takeoff and departure procedures

Figure A5.11. (Sheet 11 of 20) .

11
<b><u>SELF-CONTAINED APPROACH BRIEFING (Continued)</u></b>
14. Emergency procedures
a. Loss of NVGs
b. Emergency Brakes

Figure A5.12. (Sheet 12 of 20) .

12
<b><u>AAR BRIEFING</u></b>
b. Emergency Brakes
1. Number and call sign of tankers and receivers
2. Refueling track name and location
3. Type rendezvous/procedures
4. Tanker/receiver altimeter settings and rendezvous/refueling altitudes
5. Formation procedures (if applicable)
6. Scheduled onload
7. Use of radios and NAVAIDS
a. Tanker/receiver frequencies
b. Air-to-Air TACAN setting
c. Mandatory radio calls
d. Communication assignment
8. Defensive System Settings
9. Emergency procedures
a. Line Rupture
b. Leak

Figure A5.13. (Sheet 13 of 20) .

13
<b><u>JUMPMaster/TROOP COMMANDER BRIEFING</u></b>
1. Manifest
2. Type load, number/weight of bundles/personnel
a. Weight
b. Chutes
c. FS Position
d. Markings
3. Dangerous materials/Nonstandard loads
4. Control times
a. Load
b. Stations
c. Departure
d. En route time to objective
e. TOT/TOA
5. Warnings and advisories
6. Visual and verbal signals
7. Cabin lighting and jump light intensity and use
8. Loadmaster/jumpmaster/troop commander responsibility regarding movement in the aircraft
9. Airdrop
a. Type checklist
b. Opening ramp and door/paratroop doors
c. IP Location
d. Slowdown Type
e. Altitude/Airspeed/Heading

Figure A5.14. (Sheet 14 of 20) .

Figure A5.15. (Sheet 15 of 20) .

<b>15</b>
<b><u>JUMPMaster/TROOP COMMANDER BRIEFING</u></b>
<b><u>(Continued)</u></b>
10. Rapid offload/onload operations
a. Taxi plan/offload location
b. Aircraft parking location
c. Aircraft ground time
d. Onload procedures/departure plan
11. Defensive System Settings
12. Objective Area Considerations
13. Emergency procedures
a. Malfunctions during airdrop/minimum bailout altitude
b. Manual gate cut
c. Load jettison procedures
d. Fouled parachutist procedures
e. Decompression sickness
f. No drop/salvo procedures
g. Emergency taxi escape route (infil/exfil)

Figure A5.16. (Sheet 16 of 20) .

16
<b><u>CSO MISSION BRIEFING</u></b>
1. Departure time
2. Latest takeoff time
3. Departure routing
4. En route
a. Altitude profile
b. ESA location
c. Speeds
d. Turn point constraints
e. Start climb points and climb angle
f. Route adjustments
g. Highest terrain/obstacles en route
h. Special use airspace/no fly zones
i. Coast in/coast out points
j. En route weather penetration
k. Warning times and locations
l. Lead changes
5. Control points (push times, RZ/ARCT, TOTs, TOAs)
6. Objective area (DZ/LZ)
a. Recognition
b. Size, shape, elevation
c. Type and weight of load
d. Type of drop or approach
e. Inbound course and DZ/LZ axis

Figure A5.17. (Sheet 17 of 20) .

17
<b><u>CSO MISSION BRIEFING (Continued)</u></b>
f. Drop/approach altitude
g. Drop/approach airspeed
h. Approach MDA
i. Forecast wind vector
j. CARP/HARP data
k. Duration of green light or anticipated ground time
l. Salvo area
m. Obstructions and surrounding terrain
n. Multiple passes (racetracks)
o. Escape/go-around procedures
7. Destination recovery procedures
8. Deconfliction of routes and target area
9. Navigation equipment abort items
10. Emergency landing fields
11. Crew coordination items (RADAR range, cursor & EO/IR use, fuel transfers, communications, etc.)

Figure A5.18. (Sheet 18 of 20) .

18
<b><u>FORMATION BRIEFING</u></b>
1. Call Signs
2. Parking Locations
3. Comm Check: <ul style="list-style-type: none"><li>a. Primary/Secondary: VHF/UHF</li><li>b. Primary crew position assigned</li><li>c. Call sign: Push/Go</li></ul>
4. Start/Taxi/Route
5. Takeoff Procedure: <ul style="list-style-type: none"><li>a. Type: Interval/Feed-On</li><li>b. Ready Signal:</li><li>c. Abort Call: Sympathetic Intentions: Delay/Continue</li><li>d. Airspeed:</li><li>e. Altitude:</li><li>f. Heading:</li><li>g. Lighting:</li></ul>
6. IMC Break Procedures: Call Sign, Heading, Base Altitude, <u>Airspeed</u>
7. Power Settings: 1000HP either side (1.5 knob with)
8. Impromptu Rendezvous: Lead will be directive!
9. En Route Lighting: Covert – Form Lights <ul style="list-style-type: none"><li>a. #2 carries Overt Strobe for training</li></ul>
10. Radio Procedures: DZ/LZ/HAAR/TAAR/AAR:
11. E-TCAS: TA Only – Wingmen Operate w/ATC – OFF



Figure A5.19. (Sheet 19 of 20) .

19
<b><u>FORMATION BRIEFING (Continued)</u></b>
12. Formation Geometry: <ul style="list-style-type: none"><li>a. Fluid Trail:</li><li>b. Radar Trail:</li></ul>
13. Formation Threat Calls: Radio/Lost Sight
14. Use of "BLIND" and "KNOCK IT OFF" Calls
15. Formation Contracts: <ul style="list-style-type: none"><li>a. Lead leads</li><li>b. Wingmen always climb to avoid lead</li><li>c. Lead should never have to descend to avoid a conflict</li><li>d. Wingman never flies under or in front of lead</li><li>e. Lead will use distance-to-go from next WP to identify rally point for reassembling the formation</li></ul>

Figure A5.20. (Sheet 20 of 20) .

20
<b><u>DAY PRIOR ROUTE STUDY</u></b>
Objective: Insure Charts, Flight Plan, SCA plates, CARPs and Set-up Sheets agree.
<b>Flight Plan:</b>
1. Turn Points
2. Constraints
a. Airspeed
b. Altitudes
c. C/Ds
3. TOT/TOAs
<b>Route Study:</b>
1. Route ESA
2. Turn point MSAs
3. Start Climb Points
a. TAC Plots Associated
4. Cursor Targets
a. OAPs
5. 20/10 Minute Warnings
6. Major Deviations off the white line
a. Threat locations
7. Formation
a. Lead changes
b. IMC Breaks
c. Slow Downs

## Attachment 6

### AIRDROP OPERATIONS

**A6.1. General.** This attachment provides Airdrop guidance for specialized loads for MC-130J aircraft. The guidance in this attachment supplements the procedures outlined in AFI 13-217, *Drop Zone and Landing Zone Operations*, and AFI 11-231, *Airdrop Operations*.

**A6.2. Military Free Fall (MFF).** For drops conducted via high altitude low opening (HALO) or high altitude high opening (HAHO), positive identification of the drop zone area must be confirmed electronically or visually prior to calling the release. For MFF, all available navigational aids will be used to assist in positioning the aircraft over the HARP. (T-2)

A6.2.1. To the maximum extent possible on training and exercise missions, unless prevented by airspace restrictions or other mission factors, update the preflight winds at each altitude used to compute the HARP. Obtain these winds as near the DZ as possible.

A6.2.2. Drop scores should be obtained after each pass in order to ascertain the presence or previously unobserved wind phenomena (i.e., wind shear) or other environmental considerations in the vicinity of the drop zone. Aircrews conducting military free fall training operations should coordinate with drop zone control personnel to obtain drop scores after each pass in order to make any necessary adjustments to subsequent passes. Crews will pass this information to the jumpmasters for consideration prior to each subsequent pass. (T-3)

A6.2.3. Aircrew will ensure all aspects of MFF airdrops are discussed in detail at the aircrew/jumpmaster briefing. (T-3) Insist on positive feedback when discussing HARP location and wind data as well as resolving what items will be passed to the jumpmaster during flight. Terminology should be clear and unambiguous.

A6.2.4. For MFF training operations, crews will plan with either a safety factor no larger than 80% or an approach/safety altitude of not less than 1,000 feet. (T-2)

A6.2.5. For all MFF operations, CSOs will provide the jumpmaster with a magnetic course  $\pm 5^\circ$  and a distance from the release point to the drop zone. In-flight changes to the HARP location or significant wind changes will be relayed to the jumpmaster as soon as possible. (T-3)

A6.2.6. During all MFF drops once the green light is on, crews may delay turning on the red light until they reach the trailing edge of the updated LAR, minus an appropriate safety percentage, if applicable. During crew directed drops the green light shall be turned on at the computed release point or at a point coordinated with the jumpmaster, provided it falls on or within the LAR. During JMD drops the crew will turn on the green light upon entering the leading edge of the updated LAR, or as coordinated with the Jumpmaster. At any point during the airdrop sequence if the crew believes the drop may occur outside safe parameters, turn on the red light. (T-2)

**A6.3. Calculating a HARP.** The MC-130J Mission Computer has an internal capability to calculate a LAR and may be used in conjunction with the following alternate procedures for mission planning and execution of MFF:

A6.3.1. The MC-130J has a hard coded 20.8 for Forward Drive in the CNI-MU; the CNI Safety Factor derived from the "LAR calculator" will calculate the proper ratio based on the

actual FD of the parachute being dropped when entered into the CNI-MU. Due to the performance capability of newer generation chutes, the "LAR calculator" may generate a safety factor > 99%. In this case, when full use of the LAR is desired (maximum offset), aircrew should use a tac plot to depict the accurate size of the LAR generated by the "LAR calculator" on navigation displays. When the center of the aircraft on the NAV Radar is fully inside the tac plot, the green light may be turned on.

A6.3.2. **HALO** , use the following procedures to compute the release point and LAR:

A6.3.2.1. Compute the High Velocity (Freefall) vector using the D=KAV procedures in AFI 11-231. This results in a drift distance in meters.

A6.3.2.2. Compute the Deployed Drift Effect using the following formulas adapted from AFI 11-231, where:

DWE = DEPLOYED WIND EFFECT VECTOR, IN METERS

DDD = DEPLOYED DRIVE DISTANCE VECTOR, IN METERS

A = ACTUATION ALTITUDE (AGL), IN FEET

SF = SAFETY FACTOR, IN FEET (A SAFETY BUFFER FROM EXIT TO ASSEMBLY OF PARACHUTISTS UNDER CANOPY AND FOR ASSEMBLY AT A CERTAIN ALTITUDE ONCE THE "FLIGHT" ARRIVES OVER THE DROP ZONE, NORMALLY 2,000; 1,000 FEET FOR ASSEMBLY AND 1,000 FEET FOR APPROACH). AIRCREW WILL CONFIRM WITH THE JUMPMaster PRIOR TO EXECUTION.

FD = FORWARD DRIVE OF PARACHUTE IN KNOTS (REFERENCE APPROVED BALLISTIC DATA)

V = AVERAGE DEPLOYED WIND VELOCITY, IN KNOTS

K = BALLISTIC CONSTANT FOR THE PARACHUTE BEING USED (REFERENCE THE  $K^4$  COLUMN FROM THE HAHO TAB PERSONNEL BALLISTIC DATA, AFMAN 11-411, *SPECIAL FORCES MILITARY FREE-FALL OPERATIONS*, OR REFERENCE NATICK-APPROVED BALLISTICS)

1852 = CONSTANT TO CONVERT NAUTICAL MILES TO METERS

**\*\*NOTE THAT WHILE THE EQUATIONS BELOW ARE FOR A HALO AIRDROP, YOU MUST USE THE *HAHO* “K” FACTOR LISTED IN THE PERSONNEL BALLISTIC DATA, AFMAN 11-411 OR APPROVED BALLISTICS\*\***

DEPLOYED WIND EFFECT VECTOR:

$$DWE = \left[ \frac{(A - SF) \times (V)}{K \times 1000} \right] \times 1852$$

DEPLOYED DRIVE DISTANCE VECTOR:

$$DDD = \left[ \frac{(A - SF) \times (FD)}{K \times 1000} \right] \times 1852$$

A6.3.2.3. Plotting instructions:

A6.3.2.3.1. Select the properly scaled chart (1:250,000 scale or larger is recommended).

A6.3.2.3.2. Plot the deployed wind effect vector (upwind of the high velocity).

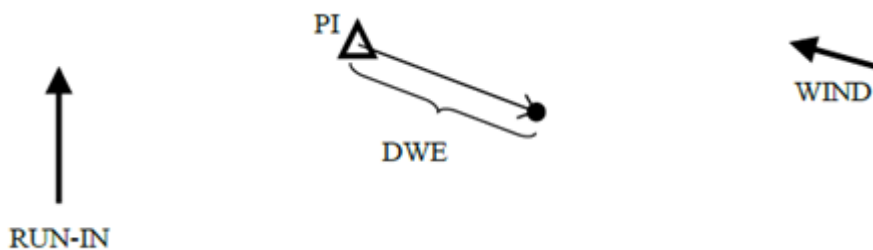

A6.3.2.3.3. Plot the high velocity vector upwind of the point of impact.

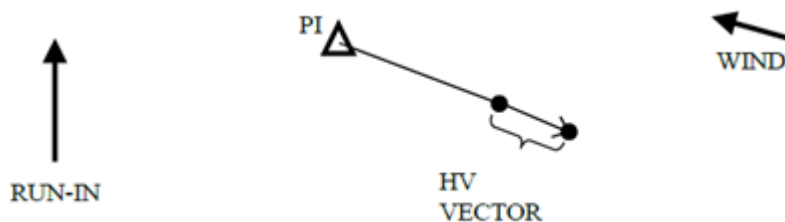

A6.3.2.3.4. Plot the computed Forward Travel Distance (FTD) in the reciprocal direction of the run-in course to compensate for forward travel of the jumpers immediately following aircraft exit. This is the HARP.

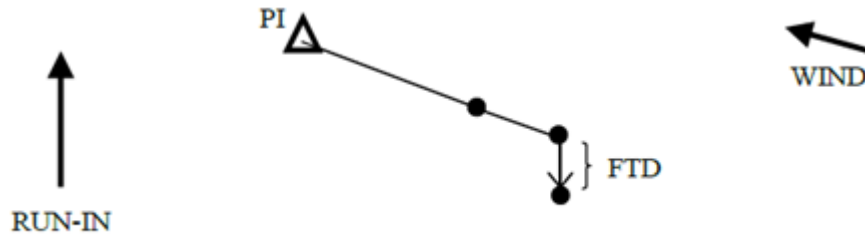

A6.3.2.3.5. Plot the deployed drive distance vector. Starting at the end of the FTD plot, use the drive distance as a radius and plot a circle. This circle represents the LAR. A HALO release can be made from any point in or on this circle.

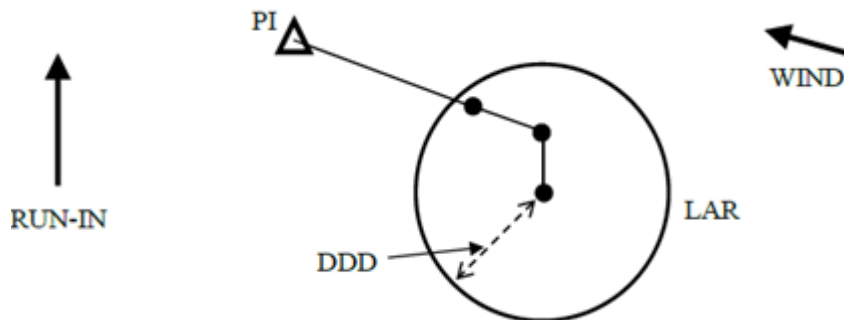

A6.3.2.4. **WARNING:** Dropping at the edge of the LAR puts the parachutists at their maximum theoretical drive distance. In the interest of safety, a percentage of the computed parachute drive distance should be used. Use a safety factor of no more than 80% in training, unless an approach/safety altitude of 1,000 feet or more was used, to account for jumper proficiency, DZ size, and non-uniform winds.

A6.3.2.5. Compute the maximum LAR stopwatch time by using the following formula:

$$\left[ \left( \frac{\text{Groundspeed (knots)}}{1.94} = \frac{\text{DDD (meters)}}{\text{Stopwatch Time (seconds)}} \times 2 \right) \times \text{Safety \%} \right]$$

A6.3.2.6. This represents the maximum amount of time the green light may remain illuminated, with the HARP located halfway to this time. For example, if the maximum LAR stopwatch time is 24 seconds, the airplane will enter the adjusted LAR 12 seconds prior to the HARP, pass through the HARP, and will leave the adjusted LAR 12 seconds after the HARP. Note that if jumper offset is desired and the crew does not pass through the computed HARP, actual green light time will be less than the maximum above.

A6.3.2.7. If Jumper offset is desired, select the desired release point inside the LAR and the desired red light point inside or on the LAR. Measure the distance between these points and use the formula below to compute the green light time:

$$\frac{\text{Groundspeed (knots)}}{1.94} = \frac{\text{LAR Travel Distance (meters)}}{\text{Stopwatch Time (seconds)}}$$

A6.3.2.8. Crews may use the “LAR CALCULATOR” excel spreadsheet released with the personnel ballistic tables to perform the above computations. Once plotted, crews will select a desired release point inside the LAR and confirm the release point with aircraft avionics.

A6.3.3. **HAHO** , use the following procedures to compute the release point and LAR:

A6.3.3.1. Do not compute a high velocity vector. Begin by computing the deployed drift effect using the following formulas, where:

DWE = DEPLOYED WIND EFFECT VECTOR, IN METERS

DDD = DEPLOYED DRIVE DISTANCE VECTOR, IN METERS

A = ACTUATION ALTITUDE (AGL), IN FEET

SF = SAFETY FACTOR, IN FEET (A SAFETY BUFFER FROM EXIT TO ASSEMBLY OF PARACHUTISTS UNDER CANOPY AND FOR ASSEMBLY AT A CERTAIN ALTITUDE ONCE THE "FLIGHT" ARRIVES OVER THE DROP ZONE, NORMALLY 2,000; 1,000 FEET FOR ASSEMBLY AND 1,000 FEET FOR APPROACH). AIRCREW WILL CONFIRM WITH THE JUMPMaster PRIOR TO EXECUTION.

FD = FORWARD DRIVE OF PARACHUTE IN KNOTS (REFERENCE APPROVED BALLISTIC DATA)

V = AVERAGE DEPLOYED WIND VELOCITY, IN KNOTS

K = BALLISTIC CONSTANT FOR THE PARACHUTE BEING USED (REFERENCE THE  $K^4$  COLUMN FROM THE HAHO TAB PERSONNEL BALLISTIC DATA, AFMAN 11-411 OR REFERENCE NATICK-APPROVED BALLISTICS)

1852 = CONSTANT TO CONVERT NAUTICAL MILES TO METERS

DEPLOYED WIND EFFECT VECTOR:

$$DWE = \left[ \frac{(A - SF) \times (V)}{K \times 1000} \right] \times 1852$$

DEPLOYED DRIVE DISTANCE VECTOR:

$$DDD = \left[ \frac{(A - SF) \times (FD)}{K \times 1000} \right] \times 1852$$

#### A6.3.3.2. Plotting instructions.

A6.3.3.2.1. Select the properly scaled chart (1:250,000 scale or larger is recommended).

A6.3.3.2.2. Plot the deployed wind effect vector upwind of the high velocity.

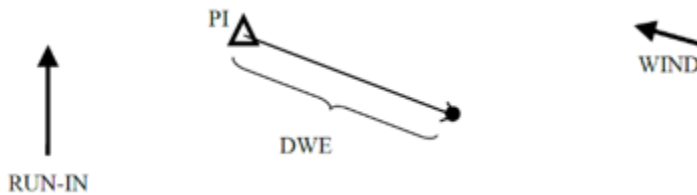

A6.3.3.2.3. From the deployed wind effect vector, plot the computed FTD in the reciprocal direction of the run-in course to compensate for forward travel of the jumpers immediately following aircraft exit. This is the HARP.

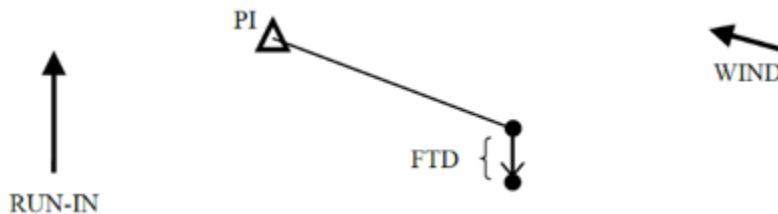

A6.3.3.2.4. Plot the deployed drive distance vector. Starting at the end of the forward travel distance plot, use the drive distance as a radius and plot a circle. The circle represents the LAR. A HAHO release can be made from any point in or on this circle.

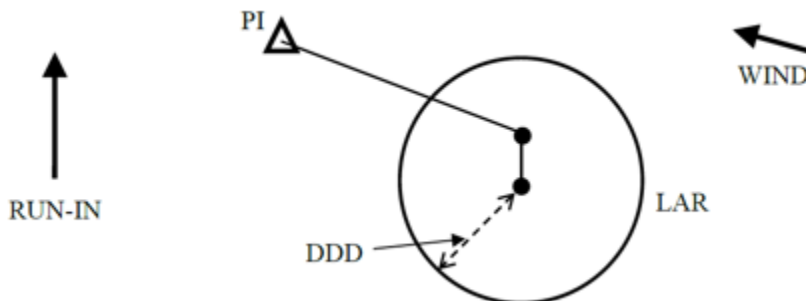

A6.3.3.2.5. **WARNING:** Dropping at the edge of the LAR puts the parachutists at their maximum theoretical drive distance. In the interest of safety, a percentage of the



computed parachute drive distance should be used. Use a safety factor of no more than 80% in training, unless an approach/safety altitude of 1,000 feet or more was used, to account for jumper proficiency, DZ size, and non-uniform winds.

A6.3.3.3. Compute the maximum LAR stopwatch time by using the following formula:

$$\left[ \left( \frac{\text{Groundspeed (knots)}}{1.94} = \frac{\text{DDD (meters)}}{\text{Stopwatch Time (seconds)}} \right) \times 2 \right] \times \text{Safety \%}$$

A6.3.3.4. This represents the maximum amount of time the green light may remain illuminated, with the HARP located halfway to this time. For example, if the maximum LAR stopwatch time is 24 seconds, the airplane will enter the adjusted LAR 12 seconds prior to the HARP, pass through the HARP, and will leave the adjusted LAR 12 seconds after the HARP. Note that if jumper offset is desired and the crew does not pass through the computed HARP, actual green light time will be less than the maximum above.

A6.3.3.5. If Jumper offset is desired, select the desired release point inside the LAR and the desired red light point inside or on the LAR. Measure the distance between these points and use the formula below to compute the green light time:

$$\frac{\text{Groundspeed (knots)}}{1.94} = \frac{\text{LAR Travel Distance (meters)}}{\text{Stopwatch Time (seconds)}}$$

A6.3.3.6. Crews may use the “LAR CALCULATOR” excel spreadsheet released with the personnel ballistic tables to perform the above computations. Once plotted, crews will select a desired release point inside the LAR and confirm the release point with aircraft avionics.

A6.3.3.7. For larger distances, measurement in nautical miles instead of meters may be desired. In these cases, divide the appropriate distance by 1852 to convert the measurement from meters to nautical miles.

**A6.4. Combat Rubber Raiding Craft (CRRC)/Rigging Alternate Method Zodiac (RAMZ) specific Procedures.** *WARNING:* The aircraft tends to pitch up as the load exits the aircraft. This pitch must be anticipated and controlled to allow no more than 2 or 3° additional pitch. Do not over control to the point that negative G forces are encountered. (T-3)

A6.4.1. CRRCs may be dropped in a stacked configuration allowing up to four CRRCs to be dropped on a single pass. One CRRC platform can be dropped using the standard CDS or CRS checklist. When two CRRC platforms are dropped on a single pass, use the CDS checklist. Two CRRC platforms with up to 18 personnel or one CRRC platform with up to 19 personnel can be airdropped on one pass. Rigged IAW TO 13C7-51-21, *Airdrop of Supplies and Equipment: Rigging Loads for Special Operations*. If aircraft gross weight exceeds 120,000 pounds, use 140 KCAS flap setting chart. **Exception:** For combination drops use 130 KCAS and 130 KCAS flap setting chart.

A6.4.1.1. Emergency procedures. Use CDS airdrop emergency procedures when dropping a CRRC.

A6.4.1.2. Training and Exercises. One or more recovery boats will be in position to recover platforms, parachutes and personnel. (T-2) The boat should be displaced 400 yards

or more from the DZ axis. The CSO or PM can confirm the release point and offset distance visually or by using radar returns.

A6.4.1.3. DZ Axis. Unless requested different by the user, the DZ axis will be into the drop altitude wind ( $\pm 30^\circ$ ) when the wind is 5 knots or greater. The jumpmaster will be advised if this cannot be done. (T-3)

A6.4.1.4. Backup Drop Platform. The raiding party exits when the pilot chute deploys. In operational employments, a second platform may be carried as a backup in case the main chute fails following pilot chute deployment. Backup platform release point and aircrew or raiding party communication and procedures will be coordinated prior to the mission. (T-3) Procedures and tactics will also be coordinated for airdrop of a second platform and party, if applicable. (T-3)

A6.4.1.5. The following will apply when dropping two CRRCs in one pass: (T-2)

A6.4.1.5.1. The forward release gate must be manually cut by the loadmaster.

A6.4.1.5.2. The second loadmaster must be positioned in the paratroop door prior to completion of the ten-minute warning. (T-2)

A6.4.1.5.3. NVGs are required for the airdrop of two CRRCs on one pass at night.

A6.4.2. RAMZ. The RAMZ consists of a deflated Zodiac F470 combat rubber raiding craft. The RAMZ engine is configured in a plywood box and secured in a standard A-22 container using two T-10 parachutes. When rigged, the RAMZ package weighs between 600 and 1,000 pounds.

A6.4.2.1. Emergency Procedures. Follow either the CDS emergency procedures or fouled parachutist procedures.

A6.4.2.2. Aircraft Preparation. Aircraft preparation will be in accordance with TO 1-C-130J-9. The RAMZ package will be delivered rigged and prepared for loading. The loadmaster is responsible for aircraft rigging, attaching the static line and securing the package. When the bundle is used in conjunction with SAR operations, it is not uncommon for the STS or Pararescue (PJ) team to require the flexibility to determine method of deployment (static line or MFF) after they determine weather conditions at the recovery site. In this case, the loadmaster should prepare the aircraft to allow for either option and complete all bundle rigging with the exception of static line attachment. In-flight prior to the 20 minute warning, the team along with the crew will determine the method of deployment. At this point, the loadmaster will attach the anchor cable to the appropriate static line and comply with **Paragraph 17.16.6.8** (In-flight Rigging Procedures). The package is rigged and dropped using normal CDS combination procedures, or rigged on the ramp using CRL procedures.

A6.4.2.3. Deployment. Checklist items up to and including the six-minute advisory may be accomplished prior to identifying the target. Accomplish the slowdown using normal slowdown procedures.

A6.4.2.4. DZ Axis. If possible, the DZ axis will be into the wind ( $\pm 30^\circ$ ) for MFF drops if drop altitude wind is 5 knots or greater. The jumpmaster will be advised when this cannot be complied with. Release for static line deployments can be either into the wind or

downwind. **WARNING:** MFF jumpers will not exit until RAMZ static lines have been retrieved. (T-2)

A6.4.2.5. Release Point. The CSO determines the release point. If the bundle is rigged using ramp bundle procedures the loadmaster will manually cut the RAMZ bundle loose which will signal the jumpers they are clear to jump. MFF jumpers will exit approximately 6 seconds after load release. Static line jumpers will exit immediately after the load release. (T-2)

### **A6.5. Joint Precision Airdrop System (JPADS) Procedures.**

A6.5.1. The term JPADS refers to GPS-guided equipment and I-CDS airdrops that are planned using the Consolidated Airdrop Tool (CAT).

A6.5.2. JPADS certified aircrews are authorized to use the CAT laptop and software (a stand-alone system) to calculate release points for JPADS/I-CDS operations.

A6.5.2.1. MFF airdrops only, aircrews can input dropsonde collected winds into onboard airdrop systems, utilize the Air Force Weather Agency forecast/model during mission planning and incorporate dropsonde collected winds when calculating HARP in MAJCOM approved airdrop planning software for personnel.

A6.5.2.2. The collected winds may be entered into the wind/temperature summary layer for use in HARP calculation. **Note:** Drop sonde winds are collected in magnetic or true so winds may require conversion to true before entry into mission computers.

A6.5.3. JPADS certified crews are authorized JPADS/I-CDS airdrop operations in VMC and IMC above 3,000 feet AGL without the use of a Radar Beacon or Ground Radar Aerial Delivery System.

A6.5.4. During the drop sonde release, use of zero flaps at speeds between 170 – 180 KCAS is required to preclude drop sonde tail strikes. Loadmasters should release the drop sondes from the corners of the cargo ramp.

A6.5.5. Wind Limits. Wind limitations are unrestricted for drop sonde operations, and as published for all other parachutes.

A6.5.6. For all training drops the drop sonde will be planned to land in the intended impact/drop area using the release point determined by the JPADS-MP. (T-2) The planned release point may be programmed in the CNI-MU into the mission computer as a normal (non-drop) leg, or as a CARP in the MSN pages with a non-steerable chute selected and enter 0.0 for FTT, 000/0 for BALLISTIC WIND, and verify CARP PROG 1/2 CARP reads 0/0. Aircraft position will be confirmed either by GPS with a FOM of 4 or better or via aircraft sensor updates. (T-2)

A6.5.7. Equipment Drops. Aircraft position will be confirmed either by GPS with a FOM of 4 or better or via aircraft sensor updates. (T-2) For non-GPS guided drops CSOs will validate the JPADS-MP release point via normal CARP procedures. (T-2)

**A6.6. Low Cost Aerial Delivery System (LCADS):** The Low Cost Aerial Delivery System is a one-time use, stand-alone airdrop system consisting of a modular suite of low cost airdrop items, and be comprised of parachutes, containers, platforms, and other air items configured for low-velocity, high-velocity and free-fall drop aerial delivery of loads.

#### A6.6.1. Low Cost Aerial Delivery System-Low Velocity (LCADS-LV).

A6.6.1.1. LCADS-LV Ballistics. LCADS-LV will be dropped using the ballistics IAW AFI 11-231 or published Air Transportation Test Loading Agency (ATTLA) memorandum. (T-2) Minimum and maximum altitudes will be IAW ATTLA CDS & Door Bundle Parachute Drop Limits. (T-2)

A6.6.1.2. Rigging. Breakaway static lines will be used regardless of altitude. The static line break tie will be full strength type III nylon (550) cord for all LCADS-LV parachutes. (T-2) **Note:** Use of gutted type III nylon (550) cord will result in chute deployment failure. Joint airdrop inspectors will ensure proper static line configuration, including anti-oscillation ties. (T-2)

#### A6.6.2. Low Cost Aerial Delivery System-High Velocity (LCADS-HV).

A6.6.2.1. LCADS-HV is not authorized for training use. LCADS-HV is authorized for contingency missions and developmental/Developmental Test and Evaluation/(OT&E) missions.

A6.6.2.2. LCADS-HV will be dropped using the ballistics IAW AFI 11-231 or published Air Transportation Test Loading Agency (ATTLA) memorandum. Minimum and maximum altitudes will be IAW ATTLA CDS & Door Bundle Parachute Drop Limits.

A6.6.2.3. LCADS-HV Parachutes are factory-rigged in a breakaway static line configuration and must always be rigged for breakaway on the aircraft regardless of drop altitude. Failure to use breakaway will result in damage to the aircraft. The static line break tie will be gutted Type III nylon (550) cord for all LCADS-HV parachutes. Joint airdrop inspectors will be vigilant and ensure proper static line configuration, including anti-oscillation ties. (T-2)

#### A6.6.3. Low Cost Aerial Delivery System-Low-Altitude (LCLA).

A6.6.3.1. LCLA is one of the Army's low cost airdrop systems. LCLA was designed to provide very low-altitude aerial resupply using small fixed-wing and rotary-wing aircraft.

A6.6.3.2. LCLA parachutes are compatible with A-7A and A-21 containers. Containers may be rigged with a single parachute or with clusters of up to three parachutes. LCLA parachutes will be rigged with non-breakaway static lines. (T-2)

A6.6.3.3. Use personnel/container ramp load checklist procedures. **Exceptions:**

A6.6.3.3.1. Use 50 percent flaps for all LCLA drops.

A6.6.3.3.2. Position anchor cable stops at FS 803. (T-2)

A6.6.3.4. For airdrops below approved en route low-level altitudes, descent to drop altitude will begin no earlier than the IP. (T-2)

A6.6.3.5. All LCLA parachutes will be rigged non-breakaway. When multiple parachutes are rigged on a bundle, ensure that the static lines are taped together with masking tape in 18-inch intervals. If the time between airdrops does not allow for removal of static line clevis/snap hook, you may leave the clevis/snap hook attached for the next airdrop as long as you cut the static lines free (combat operations only). It is advisable to ensure that the anchor line cable clips are facing outboard and are taped to avoid static line entanglement.

Anchor cable arms will not be lowered during LCLA operations. Immediate turns (escape) just after the airdrop, prior to static line retrieval, may cause static lines to wrap around the opposite anchor cable. When cutting static lines away (combat operations only) with the door open, they have historically wedged themselves along the longeron and can interfere with the flight controls. Below are some options to choose from when cutting away static lines. Option 1. First retrieve the static lines after "Load Clear." Close the cargo door and leave the ramp down. Then cut the static lines, throw them out of the aircraft and continue with normal ramp and door closure procedures. Option 2. Retrieve the static lines and close the ramp and door. Cut the static lines and throw them out of the aircraft while opening the ramp and door on the next drop.

**A6.7. 2K HALO.** 2K HALO, also referred to as 2-stage equipment, is a 2-stage, unguided cargo delivery system that nearly free falls under a stabilization chute until an activation device deploys a cargo parachute.

A6.7.1. 2K HALO can be rigged with a variety of parachutes. Maximum drop altitude will be IAW applicable ATTLA Parachute Drop limits for the stabilization chute. (T-2) Minimum drop altitude will be 2000 feet AGL with an activation altitude no lower than 200 feet plus the minimum drop altitude for the applicable second-stage chute, until incorporated into AFI 13-217. (T-2) This accounts for iWAD activation error (+/-200') and allows time for the activation device to deploy the cargo parachute and the load to stabilize under that parachute.

A6.7.2. The integrated wireless activation device (iWAD), is the MAJCOM approved activation device. (T-2) If any other activation device is used, the user will accept all responsibility for damage to equipment or personnel prior to conducting airdrop operations.

A6.7.3. HARP Pro 2S is authorized for calculating the HARP. (T-2) Aircrews will use the most accurate weather data available from approved weather sources for preflight calculations. (T-2) Airdrops conducted in training should be recalculated in flight using winds collected from on board aircraft sources.

A6.7.4. Aircrews will conduct a collateral damage estimate (CDE) of the early activation of the iWAD device to ensure bundle/bundles will not impact populated areas in the event of a malfunction. If the CDE displayed falls off DZ or outside of a restricted area, operations may continue with SQ/CC or deployed equivalent approval provided the CDE with reasonable depiction for wind error does not show the bundle impacting populated areas. (T-2) This function is available in HARP Pro 2S.

A6.7.5. Minimum drop zone size when conducting AF unilateral training will be IAW AFI 13-217, High Altitude Airdrop Resupply System (HAARS) CDS. During combat or contingency operations, the supported force determines the minimum DZ size.

A6.7.6. Conduct 2K HALO CDS airdrops at 130 KCAS when at or below 120,000 lbs. gross weight and 140 KCAS when above 120,000 lbs. gross weight. Use the low speed/CDS airdrop checklist. In all cases, a flap setting will be calculated based on aircraft gross weight to achieve a 7 degree nose up attitude to allow for a gravity extraction. Aircrews should give appropriate consideration to stall margins when conducting heavy airdrops in a nose up attitude at higher altitudes. Breakaway static lines are to be used regardless of altitude. The static line break tie will be full strength Type III nylon (550) cord for all 2K HALO CDS parachutes. Use of gutted

Type III nylon (550) cord will result in chute deployment failure. Joint Airdrop Inspectors will be vigilant and ensure proper static line configuration, including anti-oscillation ties.

A6.7.7. Conduct 2-stage door bundle and combination drops at 130 KCAS, use the low speed/Personnel airdrop checklist. Door bundles are to be rigged IAW applicable rigging manual. Equipment dropped from the paratroop doors will be equipped with non-breakaway static lines, bundles dropped from the ramp and door will be equipped with breakaway static lines. For all combination drops the equipment will be the first object to exit the aircraft. Calculate separate 2-stage equipment and personnel release points, ensure that there is an adequate LAR available for jumpers to exit the aircraft after the equipment. Use the equipment exit time as the interval between the equipment and personnel HARP. If the HARP is on the downwind side of the LAR, coordinate with the jumpmaster to ensure HARP is acceptable for personnel. Activation altitude may be modified to adjust the equipment HARP position within the personnel LAR, but must always be lower than the planned personnel actuation altitude.

**A6.8. Extracted Container Deliver System-High Speed/Low Speed (XCDS-HS/LS).** XCDS-HS airdrop will be executed with A-24 containers. XCDS-LS can be executed with A series containers listed in the interim rigging manual. XCDS-HS may be dropped with a tow-plate or direct deployment. XCDS-LS may only be dropped with a tow-plate. Minimum/Maximum load rigged weight, minimum/maximum stick rigged weights and minimum/maximum altitudes will be IAW ATTLA approved ballistic tables and drop limits.

A6.8.1. Crews will use surface winds limits for XCDS-HS/LS of 17 knots when using 45 foot parachutes and unrestricted when using 28 foot Ring Slot parachutes.

A6.8.2. Minimum DZ size for XCDS-HS is IAW AFI 13-217 limits for High Speed Low Level Aerial Delivery System (HSSLADS). During combat or contingency operations, the supported force will determine the minimum DZ size.

A6.8.3. Crews may drop between 1-8 bundles in a single pass when loaded and dropped in a single stick. Double stick XCDS-HS/LS airdrops are not approved, although two sticks may be rigged and loaded as long as they are dropped on separate passes.

A6.8.4. If dropping a single A-24 container, the bundle must have a total rigged weight of 1850lbs; if dropping two to eight A-24 containers, the minimum stick weight is 1,600 lbs. and the maximum is 16,000lbs.

A6.8.5. Crews must be aware that loading, rigging, and completing a Joint Airdrop Inspection (JAI) for XCDS can take significantly longer than conventional CDS. Experience during flight test has shown that it takes approximately 60-90 minutes to complete loading and JAI for XCDS. This delay will be even more significant when loading two sticks since the rigging of the belly band is more difficult with two sticks loaded in the aircraft.

A6.8.6. When dropping more than four XCDS bundles, the aircraft nose will pitch up noticeably during the extraction, similar to a heavy equipment extraction. Since the bundles are gravity extracted once the belly band is cut during the extraction sequence, crews are advised to let the nose of the aircraft rise during extraction to ensure that the aircraft maintains sufficient deck angle to facilitate extraction. This will cause the aircraft to climb between 50-100 feet, though airdrop accuracy should not be negatively affected.

Attachment 7

FIGURE A7.1. COMMUNICATION, NAVIGATION AND SURVEILLANCE/ AIR TRAFFIC MANAGEMENT (CNS/ATM) SYSTEMS AND PROCEDURES.

MC-130J	Certified	Operational Approval	Pilot Training Required	180J Designation (Block 10)	180J Designation (Block 18) Note 1	180J Designation Explained Additional Notes & Cautions	Required Equipment Note 2 Note 3	Reference
<b>Equipment</b>								
FM Immune	Yes	Yes	No	Not Applicable	Not Applicable	Not Applicable	Not Applicable	Not Applicable
8.33 Kilo/lo	Yes	Yes	No	Y	Not Applicable	Not Applicable	Not Applicable	-1-Section 18A
Enhanced Mode 5	Yes	Yes	No	/N	Not Applicable	DOWNLINK selected on	Not Applicable	-1-Section 18B
<b>Enroute Airspace</b>								
RNAV 1	Yes	Yes	Yes	R	02 - RNAV 1 GNSS	02 - Ship solution set to GPS-based solution	02 - 1X Operable TACAN to provide AAIM	
					04 - RNAV 1 DME/DME/RN	04 - Ship solution set to INS/RAD	04 - 2X Operable TACAN	
RNAV 2 (US Q&R Traffic)	Yes	Yes	Yes	R	C2 - RNAV 2 GNSS	C2 - Ship solution set to GPS-based solution	C2 - 1X Operable TACAN to provide AAIM	
					C4 - RNAV 2 DME/DME/RN	C4 - Ship solution set to INS/RAD	C4 - 2X Operable TACAN	
RNAV 5 (RNAV)	Yes	Yes	Yes	R	B2 - RNAV 5 GNSS	B2 - Ship solution set to GPS-based solution	B2 - 1X Operable TACAN to provide AAIM	
					B5 - RNAV 5 INS or INS DME/DME/RN	B5 - Ship solution set to INS/RAD	B5 - 2X Operable TACAN	
RNAV 10 (RNP-10 (WAIR, PACOT, NOPAC))	Yes	Yes	Yes	R	A1	Ship solution may be set up with either a GPS-based solution or INS/RAD	If GPS - 1X Operable TACAN to provide AAIM If INS/RAD - 2X Operable TACAN	
MNPS (Including NAT/OTS and NAW)	Yes	Yes	Yes	X	Not Applicable	Ship solution may be set up with either a GPS-based solution or INS/RAD	If GPS - 1X Operable TACAN to provide AAIM If INS/RAD - 2X Operable TACAN If NAT ops - 2 CW-59	-1-Section 18B -1-Section 3
RISM	Yes	Yes	Yes	W	Not Applicable	Not Applicable	See RISM section in 11-2C-12019	
RNAV point-to-point routing	Yes	Yes	No	Z	NAV/RNAV2	Random routing can be entered by Waypoint Name, Lat/Long (LL), or Point/Bearing/Distance (PBD). RNAV Always should be retrieved from database, can be entered by Waypoint Name, but not by LL or PBD.	Not Applicable	
<b>Arrival/Terminal Area/Departure</b>								
RNAV STARS	Yes	Yes	Yes	Z	NAV/RNAV1	Ship solution may be set up with either a GPS-based solution or INS/RAD. RNAV STARS must be retrieved from the database.	If GPS - 1X Operable TACAN to provide AAIM If INS/RAD - 2X Operable TACAN	-1-Section 18B
RNAV DP & SDB-Note 4	Yes	Yes	Yes	Z	NAV/RNAV1	Ship solution may be set up with either a GPS-based solution or INS/RAD. RNAV SDB must be retrieved from the database.	If GPS - 1X Operable TACAN to provide AAIM If INS/RAD - 2X Operable TACAN	-1-Section 3
<b>Not Authorized</b>								
WAAC, LAAC, RNAV (RNP) approaches, RNAV (GS) approaches, LNAV/VNAV approaches, LPV, and procedures or airspace								
<b>Notes</b>								
Note 1: See General Planning Chapter 4 for further guidance filling out 180J & DP-175s. This list is not all inclusive for 180J designation requirements.								
Note 2: In all instances TACANs must be set to AUTOTUNE.								
Note 3: For all situations, the aircraft is required to have a current navigation database and an operable Flight Director/autopilot.								
Note 4: RNAV solution for rnp0 NAV/OTS or rnp001 NAV 11-202A.								