

**BY ORDER OF THE
SECRETARY OF THE AIR FORCE**



AIR FORCE MANUAL 11-218

5 APRIL 2019

**AIR EDUCATION AND TRAINING
COMMAND
Supplement**

02 AUGUST 2019

Flying Operations

**AIRCRAFT OPERATIONS AND
MOVEMENT ON THE GROUND**

COMPLIANCE WITH THIS PUBLICATION IS MANDATORY

ACCESSIBILITY: Publications and forms are available on the e-Publishing website at <http://www.e-publishing.af.mil/> for downloading or ordering.

RELEASABILITY: There are no releasability restrictions on this publication.

OPR: AFFSA/XOF

Certified by: AF/A30
(Mr. Steven A. Ruehl)

Supersedes: AFI11-218, 28 October 2011

Pages: 46

(AETC)

OPR: 19 AF/DOV

Certified by: 19 AF/DO
(Colonel Gary Eilers)

Supersedes: AFI 11-218_AETCSUP,
01 May 2014

Pages: 3

This manual implements Air Force Policy Document 11-2, *Aircrew Operations*, by prescribing rules for the operation, movement, and control of aircraft on the ground. This instruction applies to the ground operations of all Air Force aircraft operating on an aircraft apron, ramp, or movement area at any airfield, whether military, civilian, or foreign; it applies to individuals at all levels who operate Air Force aircraft on the ground, whether military, civilian, or contractor, including the Regular Air Force, Air Force Reserve, and Air National Guard, except where noted otherwise. Ensure all records created as a result of processes prescribed in this publication are maintained in accordance with Air Force Manual 33-363, *Management of Records*, and disposed of in accordance with the Air Force Records Disposition Schedule located in the Air Force Records Information Management System. Refer recommended changes and questions about this publication to the Office of Primary Responsibility (OPR) using the AF Form 847, *Recommendation for Change of Publication*; route AF Forms 847 from the field through the

appropriate functional chain of command. This publication may be supplemented at any level, but all supplements must be routed to the OPR of this publication for coordination prior to certification and approval. The authorities to waive wing/unit level requirements in this publication are identified with a Tier (“T-0, T-1, T-2, or T-3”) number following the compliance statement. See Air Force Instruction (AFI) 33-360, *Publications and Forms Management*, for a description of the authorities associated with the Tier numbers. Submit requests for waivers through the chain of command in accordance with [paragraph 1.2](#) of this manual. The use of the name or mark of any specific manufacturer, commercial product, commodity, or service in this publication does not imply endorsement by the Air Force.

(AETC) AFMAN 11-218, *Aircraft Operations and Movement on the Ground*, is supplemented as follows: This supplement establishes Air Education and Training Command (AETC) rules for the operation, movement, and control of aircraft on the ground. It applies to all AETC flying training units. With the exception of the associate instructor pilot program, this supplement does not apply to Air Force Reserve Command or Air National Guard units. Units may supplement this instruction as needed to address unique mission requirements. Unit supplements will not be less restrictive than the basic AFMAN or this supplement. Forward proposed unit-level supplements to this instruction to 19 AF/DOV for coordination before publication. Submit suggested improvements to this supplement via AF Form 847, *Recommendation for Change of Publication*, through command Stan/Eval channels to the 19 AF/DOV workflow email. The authorities to waive wing/unit level requirements in this publication are identified with a Tier (“T-0, T-1, T-2, T-3”) number following the compliance statement. See AFI 33-360, *Publications and Forms Management*, for a description of the authorities associated with the Tier numbers. Unless otherwise specified, 19 AF/DO is the waiver authority for this supplement. Ensure that all records created as a result of processes prescribed in this publication are maintained in accordance with AFMAN 33-363, *Management of Records*, and disposed of in accordance with Air Force Records Disposition Schedule located in the Air Force Records Information Management System.

SUMMARY OF CHANGES

This document has been substantially revised and must be completely reviewed. Major changes include: (1) reducing directive guidance as directed by the Secretary of the Air Force, (2) re-tiering directive guidance, (3) correcting administrative and grammatical errors, (4) and adopting AF Form 679, *Air Force Publication Compliance Item Waiver Request/Approval*.

(AETC) This document has been substantially revised and must be thoroughly reviewed. Major changes include: (1) deleting MAJCOM guidance for the training and evaluation requirements of personnel involved in aircraft movement on the ground; authorized to start, run, or test engines; or authorized to taxi. (2) deleting the reference to a marshalling test (3) deleting taxi and towing distances waiver authority delegation wording.

Chapter 1—OVERVIEW	4
1.1. General.....	4
1.2. Waivers.	4

AFMAN11-218_AETCSUP 02 AUGUST 2019	3
Chapter 2—ROLES and Responsibilities	5
2.1. General.....	5
2.2. Wing Commander or Equivalent.	5
2.3. Aircraft Marshalls.	7
2.3. Aircraft Marshalls.	7
2.4. Aircraft Operators.	7
Chapter 3—AIRCRAFT MOVEMENT ON THE GROUND	8
3.1. General.....	8
Figure 3.1. General Areas on an Airfield.	8
3.2. Runway Safety Area (RSA).....	8
3.3. Controlled Movement Area (CMA).....	8
3.4. Non-CMA.	9
3.5. Aircraft Surface Operations.	9
3.6. Transponder.	9
3.7. Taxi and Towing Clearance.	9
Figure 3.2. Wing Tip and Tail Growth.....	9
3.8. Air Traffic Control Light Signals.	9
Figure 3.3. Air Traffic Control Light Signals.	10
3.9. Position Lights.	10
3.10. Anti-collision or Strobe Lights.	10
3.11. Crew Requirements.....	11
Chapter 4—AERONAUTICAL LIGHTING AND OTHER AIRFIELD VISUAL AIDS	12
4.1. General.....	12
4.2. Low Visibility Operations.....	12
Figure 4.1. Airfield Markings.	12
Figure 4.2. Airfield Signs.	13
Figure 4.3. Example Airfield Lighting, Marking, and Signage.....	14
Attachment 1—GLOSSARY OF REFERENCES AND SUPPORTING INFORMATION	16
Attachment 2—AIRCRAFT MARSHALLING SIGNALS	19

Chapter 1

OVERVIEW

1.1. General. This instruction provides broad guidance for aircraft movement on the ground. It cannot address every possible situation; therefore, wing commanders should establish appropriate guidance to ensure safe aircraft movement on the ground as directed in [paragraph 2.2](#). This instruction does not apply to specialized maintenance procedures normally conducted away from aircraft aprons, ramp, and movement areas (e.g. engine runs conducted in approved sound suppressors).

1.2. Waivers. Refer to AFI 33-360. The Director of Operations, AF/A3O, is the approval authority for any non-tiered directive guidance in this manual. MAJCOMs (or subordinate units for Tier 2 and Tier 3 waivers) initiate and staff all waiver packages. Coordination through the Air Force Flight Standards Agency Flight Directives division (AFFSA/XOF), hqaffsa.xof@us.af.mil, is required for Tier 0 and Tier 1 waivers, and recommended for Tier 2 and Tier 3 waivers.

1.2.1. All Tier 0 statements are referenced to Federal Aviation Administration (FAA) Title 14, Code of Federal Regulations, Part 91, *General Operating and Flight Rules*, FAA Order JO 7110.65, *Air Traffic Control*, International Civil Aviation Organization (ICAO), Annex 2, *Rules of the Air*, or ICAO Annex 14 Volume 1, *Aerodrome Design and Operations*.

1.2.2. AFFSA/XOF pursues external agency concurrence for Tier 0 waivers and provides results to the requesting MAJCOM (e.g., an exemption to the Code of Federal Regulations).

1.2.3. Accomplish all waivers using the AF Form 679, *Air Force Publication Compliance Item Waiver Request/Approval*. Once approved, wings will send an informational copy to MAJCOM Standardization/Evaluation and AFFSA/XOF within five duty days. **(T-1)**.

Chapter 2

ROLES AND RESPONSIBILITIES

2.1. General. Wing commanders or equivalent may reference current or future revisions of the following documents when developing training, guidance, and operational execution procedures to comply with the intent of this instruction. **Note:** See [Attachment 1](#) for versions referenced at the time this manual was written.

- 2.1.1. Advisory Circular (AC) 00-34, *Aircraft Ground Handling and Servicing*,
- 2.1.2. AC 120-57, *Surface Movement Guidance and Control System*,
- 2.1.3. AC 150/5300-13, *Airport Design*,
- 2.1.4. AC 150/5210-20, *Ground Vehicle Operations to include Taxiing or Towing an Aircraft on Airports*,
- 2.1.5. AC 150/5340-1, *Standards for Airport Markings*,
- 2.1.6. AC 150/5340-18, *Standards for Airport Sign Systems*,
- 2.1.7. AC 150/5340-30, *Design and Installation Details for Airport Visual Aids*,
- 2.1.8. AFI 11-202 Volume 3, *General Flight Rules*,
- 2.1.9. AFI 13-204 Volume 3, *Airfield Operations Procedures and Programs*,
- 2.1.10. AFI 13-213, *Airfield Driving*,
- 2.1.11. AFI 21-101, *Aircraft and Equipment Maintenance Management*,
- 2.1.12. FAA-H-8083-25, *Pilot's Handbook of Aeronautical Knowledge*,
- 2.1.13. International Civil Aviation Organization (ICAO) Doc 9476-AN/927, *Manual of Surface Movement Guidance Control Systems (SMGCS)*,
- 2.1.14. UFC 3-260-01, *Airfield and Heliport Planning and Design*,
- 2.1.15. UFC 3-260-04, *Airfield and Helicopter Markings*, and
- 2.1.16. UFC 3-535-01, *Visual Air Navigation Facilities*.

2.2. Wing Commander or Equivalent. Wing Commanders will establish:

- 2.2.1. Training and evaluation requirements of personnel who are involved with aircraft movement on the ground; authorized to start, run, or test engines; or authorized to taxi. **(T-3)**.
- 2.2.2. Supervision and training requirements when authorizing programs that allow unqualified personnel to occupy a pilot seat during taxi (see [paragraph 3.11](#)); include briefing requirements, emergency procedures, and egress procedures. **(T-3)**.
- 2.2.3. Personal protective equipment requirements in accordance with AFMAN 91-203, *Air Force Occupational Safety, Fire, and Health Standards*, and AFI 48-127, *Occupational Noise and Hearing Conservation Program*. **(T-1)**.

2.2.4. Procedures for operating aircraft when waiving the 25-foot or 10-foot horizontal clearance requirements directed in **paragraph 3.7 (T-1)**. **Note:** These waivers are considered operational waivers as defined in Unified Facilities Criteria (UFC) 3-260-01, *Airfield and Heliport Planning and Design*, and are not waivers to airfield criteria or standards.

2.2.5. Any necessary airfield specific marshalling signals **(T-3)**.

2.2.5.1. **(Added-AETC)** Personnel operating T-38 aircraft will form an upright “T” by extending one hand opened horizontally over the other one hand opened vertically before moving any flight control surface. When all personnel and equipment are clear, the ground crewmember will repeat the “T” signal, which signals the operator that trim and control surface response may be checked. Once safe operation of primary flight control surfaces have been briefed, the ground crewmember will signal the operator to lower the flaps, using the “clear to lower flaps” hand signal. After the operator lowers the flaps full down and has repositioned them to the 60 percent mark, the ground crew will verify the proper horizontal tail trim position by repeating the “T” signal again followed by a thumbs up or affirmative signal.

2.2.5.2. **(Added-AETC)** T-38 Landing Gear Door Open. The pilot cups both hands in front, fingertips touching and palms separated, and then rapidly opens both hands from the wrist and straightens fingers.

2.2.5.3. **(Added-AETC)** T-38 Landing Gear Door Closed. The pilot holds both hands separated with fingers straight down and then swings both hands together and cups them to touch fingers in front of body.

2.2.5.4. **(Added-AETC)** Rotating Lights Check. The pilot or ground crewmember holds the left hand horizontally with palm down and makes a circular motion with the right index finger (finger below extended palm). The ground crewmember gives the affirmative signal if lights are operational or a negative signal (thumbs down) if lights are inoperative. The ground crewmember indicates the condition of individual lights by pointing to the location and giving the appropriate signal for affirmative or negative.

2.2.5.5. **(Added-AETC)** Hands Clear. This special signal is used when ground crewmember wants the pilot to clear both hands to prevent inadvertent switch or lever activation. The ground crewmember extends both arms with hands straight out and 30 degrees above horizon. After completing the task, he or she repeats the signal and drops both arms rapidly to the side.

2.2.5.6. **(Added-AETC)** Diverter Valve. To signal diverter valve changeover on a T-38 launch, position the left hand horizontally in front of the body with the palm down and fingers extended. Clasp the right hand into a fist, position it vertically under the left palm, and rotate the fist with the thumb going inward and right.

2.2.5.7. **(Added-AETC)** Rudder Movement. To signal rudder movement, extend the right hand forward horizontally from the elbow (palm vertical) and move the hand left or right in conjunction with movement of the rudder.

2.2.5.8. **(Added-AETC)** Aileron Movement. To signal aileron movement, extend both hands forward horizontally from the elbow (palms down) and move hands up and down in conjunction with the movement of the ailerons.

2.2.5.9. **(Added-AETC)** Horizontal Stabilizer. To signal horizontal stabilizer or elevator movement, extend both hands forward horizontally from the elbow (palms down) and move hands up and down in conjunction with the horizontal stabilizer or elevator control surface movement.

2.2.6. **(Added-AETC)** Units will develop and publish local procedures for use of radios during engine starts **(T-3)**.

2.2.7. **(Added-AETC)** Units will develop and publish local procedures and contingency plans to provide adequate fire protection while the tower or ground control is off the air **(T-3)**.

2.3. Aircraft Marshalls. Aircraft marshalls shall provide standard marshalling signals to aircraft in a clear and precise manner using the signals described in [Attachment 2](#) **(T-3)**.

2.3. (AETC) Aircraft Marshalls. When Air Force ground marshalls are not available, the pilot flying cargo or transport-type aircraft may use crewmembers or crew chiefs as marshalls only if the crewmembers can deplane safely with engines running and they are familiar with the basic marshalling signals **(T-3)**.

2.3.1. Personnel will not marshal an aircraft unless trained and qualified to carry out the functions of an aircraft marshaller **(T-3)**.

2.3.2. Aircraft marshalls will be clearly identifiable to the aircraft operator **(T-3)**. **Exception:** Flight crew personnel deplaned by the pilot in command to perform marshalling duties are not required to wear a distinctive fluorescent outer garment unless available on the aircraft.

2.3.3. Daylight-fluorescent wands will be used for signaling by all participating ground personnel during daylight hours. **(T-3)**. Illuminated wands will be used at night or in low visibility. **(T-3)**. **Exception:** Flight crew personnel deplaned by the pilot in command to perform marshalling duties are not required to use wands unless available on the aircraft; however, they should keep their hands and arms visible to the pilot in command.

2.3.4. Aircraft marshalls will ensure the area is clear of obstructions prior to marshalling an aircraft. **(T-3)**. **Note:** The design of many aircraft is such that the path of the wing tips, engines, and other extremities cannot always be monitored visually from the flight deck while the aircraft is being maneuvered on the ground.

2.3.5. When not in verbal communication with aircraft operators, aircraft marshalls will repeat the signal given by the operator when it is safe to operate that aircraft system. **(T-3)**.

2.4. Aircraft Operators.

2.4.1. Personnel operating aircraft shall take action as required by the marshalling signals **(T-3)**. When not in verbal communication with aircraft marshalls, personnel operating aircraft will initiate all signals regarding the operation of aircraft systems (speed brakes, flaps, etc.) in a clear and precise manner as shown in [Attachment 2](#) **(T-3)**.

Chapter 3

AIRCRAFT MOVEMENT ON THE GROUND

3.1. General. An airfield consists of three areas with respect to aircraft movement on the ground: the runway safety area (RSA), controlled movement area (CMA), and non-CMA (Figure 3.1).

Figure 3.1. General Areas on an Airfield.

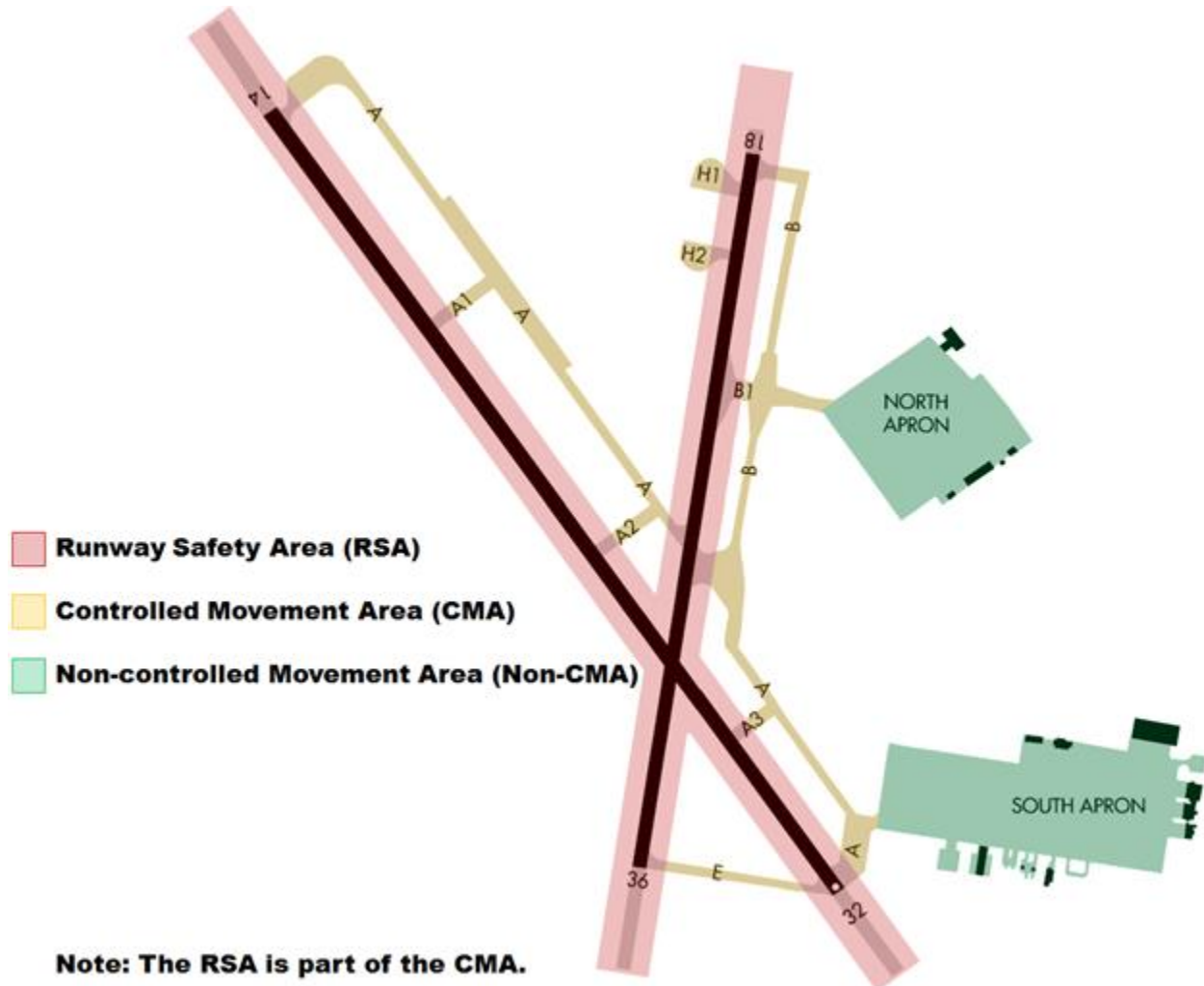

3.2. Runway Safety Area (RSA). The RSA is an area surrounding the runway intended for use by aircraft in emergency situations; it is measured from the runway ends and centerline. The RSA may extend up to 500 feet from the runway centerline and 1,000 feet beyond the runway ends. **Note:** The RSA is part of the CMA.

3.3. Controlled Movement Area (CMA). The CMA includes the surfaces of an airfield used for take-off, landing, and taxiing of aircraft, excluding aircraft ramps, aprons, and parking areas. Do not operate aircraft on the CMA without air traffic control clearance (T-0).

3.4. Non-CMA. Ramps, aprons, and parking areas not under air traffic control. Local guidance may dictate a ramp authority to contact or procedures to follow.

3.5. Aircraft Surface Operations. An aircraft operating on the CMA shall stop and wait at all lighted stop bars until the lights are switched off (T-1). Do not operate aircraft beyond runway holding position markings or within the RSA unless cleared by air traffic control (T-0). **Note:** Refer to [Chapter 4](#) for airfield markings. In case of potential collision between two aircraft operating on an airfield the following applies:

3.5.1. Approaching head on, or approximately so, each aircraft shall stop or alter its course to the right to keep well clear (T-1).

3.5.2. On a converging course, the aircraft with the other on its right shall give way (T-1).

3.5.3. An aircraft that is being overtaken by another aircraft shall have the right-of-way and the overtaking aircraft shall keep well clear of the other aircraft (T-1). **Note:** An overtaking aircraft is an aircraft that approaches another from the rear and is unable to see the aircraft's port or starboard navigation lights.

3.6. Transponder. Aircraft operating on the CMA or RSA must have the transponder on in the altitude reporting mode and Automatic Dependent Surveillance – Broadcast (ADS-B) Out transmissions enabled (if equipped) (T-2). **Exception:** The wing commander or equivalent may specify transponder operations on airfields under their authority.

3.7. Taxi and Towing Clearance. Personnel should plan taxi and towing operations so that no part of an aircraft is within 25 horizontal feet of an obstruction; account for wing tip and tail growth during turns ([Figure 3.2](#)). Do not operate aircraft within 25 horizontal feet of any obstruction without wing walkers (T-3). Do not operate aircraft within 10 horizontal feet of any obstruction (T-3). **Exception:** USAF Air Demonstration Squadron aircraft marshalled by qualified team members may taxi within 10 feet of obstructions.



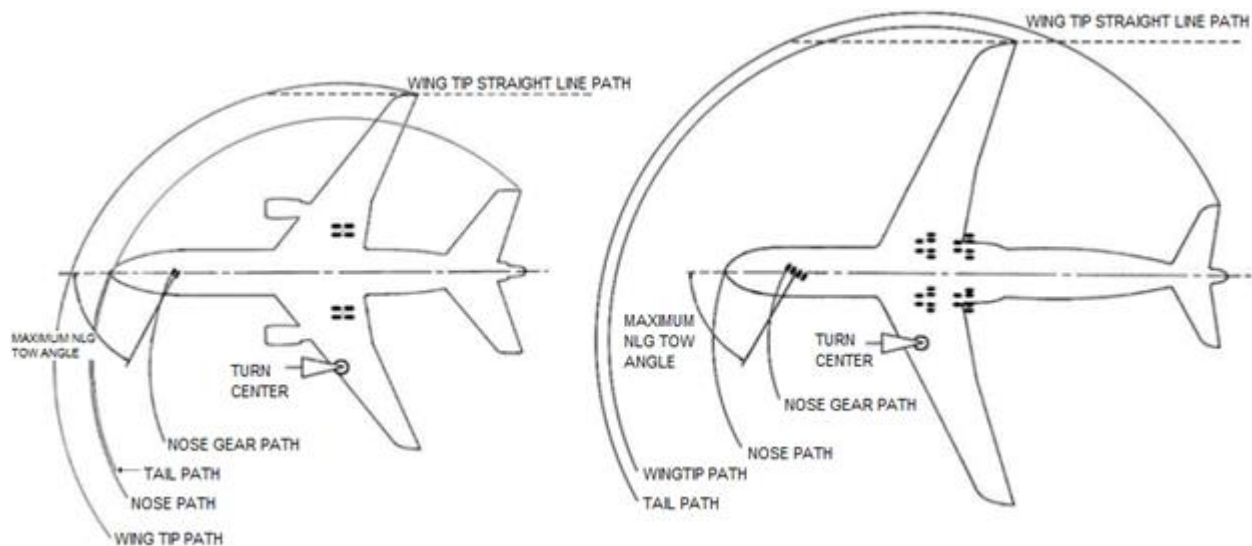



Figure 3.2. Wing Tip and Tail Growth.



3.8. Air Traffic Control Light Signals. Air traffic control towers may use the following procedures to control aircraft, ground vehicles, equipment, and personnel not equipped with a

radio or if radio contact cannot be established. Air traffic control personnel use a directive traffic control signal that emits an intense narrow light beam of a selected color (i.e., red, white, or green) when controlling traffic by light signals (Figure 3.3).

Figure 3.3. Air Traffic Control Light Signals.

<h1>Light Gun Signals</h1>	
Color and Type of Signal	Aircraft on the Ground
STEADY GREEN 	Cleared for Takeoff
FLASHING GREEN 	Cleared to Taxi
STEADY RED 	STOP
FLASHING RED 	Taxi Clear of the Runway in Use
FLASHING WHITE 	Return to Starting Point on Airport
ALTERNATING RED/GREEN 	Exercise Extreme Caution

3.8.1. Between sunset and sunrise, a person operating an aircraft on the ground wishing to attract the attention of the control tower should turn on a landing light and taxi the aircraft into a position, clear of the active runway, so that light is visible to the tower. The landing light should remain on until appropriate signals are received from the tower.

3.8.2. Acknowledge tower instructions during daylight hours by moving the ailerons or rudder; acknowledge instructions at night by blinking the landing or navigation lights. Watch the tower for light signals if a radio malfunction occurs after departing the parking area.

3.9. Position Lights. Turn on position lights between sunset and sunrise when starting or running an engine, while being towed, or when parked in an area likely to create a hazard unless clearly illuminated by an outside source (T-0). **Exception:** Aircraft that do not have power available before start shall turn them on as soon as power is available (T-0). Wing commanders will establish required procedures and lighting for towing unpowered aircraft between sunset and sunrise (T-2).

3.10. Anti-collision or Strobe Lights. Turn on anti-collision or strobe lights prior to engine start; do not turn them off until after engine shutdown (T-0). **Exception:** Aircraft that do not

have power available before engine start shall turn anti-collision or strobe lights on as soon as power is available (**T-0**). **Note:** Flashing lights may be turned off or reduced in intensity if they adversely affect the performance of duties or subject an outside observer to harmful dazzle.

3.11. Crew Requirements. Authorized personnel must occupy both seats during taxi operations if an aircraft requires two pilots for flight (**T-2**). **Exception:** Wing commanders may establish incentive, indoctrination, and orientation programs that allow unqualified personnel to occupy a pilot seat during taxi in accordance with AFI 11-401, *Aviation Management*.

Chapter 4

AERONAUTICAL LIGHTING AND OTHER AIRFIELD VISUAL AIDS

4.1. General. Personnel involved with aircraft movement on the ground should be familiar with aeronautical lighting and other airfield visual aids (**Figure 4.1**, **Figure 4.2**, and **Figure 4.3**). Additional information is available in **Chapter 2** of the *Aeronautical Information Manual*, available from the Federal Aviation Administration (FAA) website at <http://www.faa.gov/>.

4.2. Low Visibility Operations. A surface movement guidance and control system (SMGCS) plan provides guidance to and control of aircraft and ground vehicles on the airfield. Do not operate aircraft on the ground at locations where a SMGCS plan or low visibility operations are in effect without MAJCOM-developed training (**T-2**). Non-trained personnel must request a “follow me” vehicle or delay taxi operations until visibility conditions improve (**T-2**). Personnel must use the low visibility taxi route chart published for the airfield when low visibility operations are in effect (**T-1**). **Note:** Low visibility taxi route charts are not published in Department of Defense flight information publications but may be available from the State’s *Aeronautical Information Publication* or commercial vendors (Jeppesen®, etc.).

Figure 4.1. Airfield Markings.







EXAMPLE	TYPE OF MARKING	LOCATION/CONVENTION
	Holding Position.	Located across centerline within 10 feet of hold sign on taxiways and on certain runways.
	Instrument Landing System (ILS) Critical Area	Located on taxiways where the taxiways enter the ILS critical area or where aircraft on taxiway would violate ILS approach airspace.
	Taxiway/Taxiway Holding Position.	Used at airports where needed to hold traffic at a taxiway/intersection. Located to ensure wing clearance for taxiing aircraft.
	Non-CMA Boundary.	Located on boundary between CMA and non-CMA. Located to ensure wing clearance for taxiing aircraft.
	Taxiway Edge.	Located along taxiway edge where contiguous shoulder or other paved surface NOT intended for use by aircraft.
	Dashed Taxiway Edge.	Located along taxiway edge where contiguous shoulder or other paved surface is intended for use by aircraft.
	Surface Painted Holding Position.	Supplements elevated holding position signs. Required where hold line exceeds 200'. Also useful at complex intersections.
	Enhanced Taxiway Centerline	Taxiway centerlines are enhanced 150' prior to a runway holding position marking.
	Surface Painted Taxiway Direction.	Located left side for turns to left. Right side for turns to right. Installed prior to intersection.
	Surface Painted Taxiway Location.	Located right side. Can be installed on left side if combined with surface painted hold sign.

Figure 4.2. Airfield Signs.







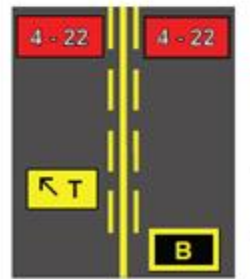



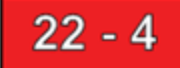



EXAMPLE	TYPE OF SIGN	LOCATION/CONVENTION
	Mandatory: Hold position for taxiway/runway intersection.	Located <u>left side</u> of taxiway within 10 feet of hold position markings.
	Mandatory: Holding position for runway/runway intersection.	Located <u>left side</u> of runway prior to intersection, and <u>right side</u> if runway more than 150' wide, used as taxiway, or has "land & hold short" ops.
	Mandatory: Holding position for runway approach area.	Located on taxiways crossing thru runway approach areas where an aircraft would enter an RSA or approach/departure airspace.
	Mandatory: Holding position for ILS critical area/precision obstacle free zone.	Located on taxiways where the taxiways enter the ILS critical area or where aircraft on taxiway would violate ILS approach airspace.
	Mandatory: No entry.	Located on paved areas that <u>aircraft</u> should not enter.
	Taxiway Location.	Located along taxiway by itself, as part of an array of taxiway direction signs, or combined with a runway/taxiway hold sign.
	Runway Location.	Normally located where the <u>proximity of two runways</u> to one another could cause confusion.
	Runway Safety Area and Runway Approach Area Boundary.	Located on taxiways on <u>back side</u> of certain runway/taxiway holding position signs or runway approach area signs.
	ILS Critical Area.	Located on taxiways on <u>back side</u> of ILS critical area signs.
	Direction: Taxiway.	Located on <u>left side, prior to intersection</u> , with an array left to right in clockwise manner.
	Runway Exit.	Located on same side of runway as exit, prior to exit.
	Outbound Destination.	Located on taxi routes to runway(s). <u>Never</u> collocated or combined with other signs.
	Inbound Destination.	Located on taxi routes to airport destinations. <u>Never</u> collocated or combined with other types of signs.
	Information.	Located along taxi routes or aircraft parking/staging areas. May not be lighted.
	Taxiway Ending Marker.	Installed at taxiway end or far side of intersection, if visual cues are inadequate.
	Distance Remaining.	Located along the sides of runways at 1000' increments.

Figure 4.3. Example Airfield Lighting, Marking, and Signage.

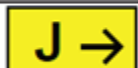

MARK D. KELLY, Lt Gen, USAF
Deputy Chief of Staff, Operations

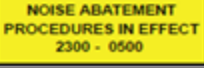
(AETC)

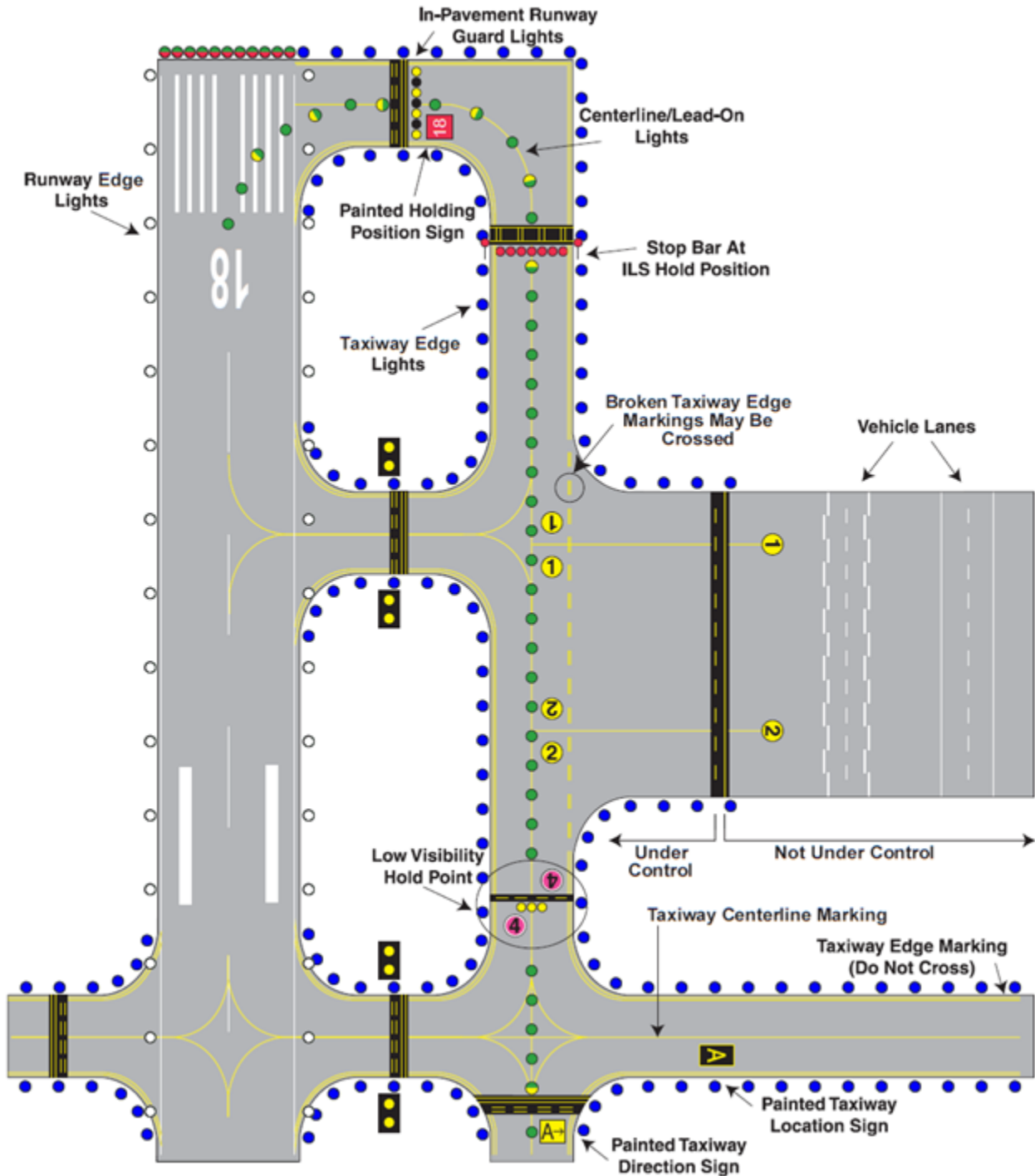
CRAIG D. WILLS, Maj Gen, USAF
Commander, 19th Air Force

Attachment 1**GLOSSARY OF REFERENCES AND SUPPORTING INFORMATION*****References***

- Advisory Circular (AC) 00-34A, *Aircraft Ground Handling and Servicing*, 29 July 1974
- AC 120-57A, *Surface Movement Guidance and Control System*, 19 December 1996
- AC 150/5300-13A, *Airport Design*, 26 February 2014
- AC 150/5210-20A, *Ground Vehicle Operations to include Taxiing or Towing an Aircraft on Airports*, 1 September, 2015
- AC 150/5340-1L, *Standards for Airport Markings*, 27 September 2013
- AC 150/5340-18F, *Standards for Airport Sign Systems*, 16 August 2010
- AC 150/5340-30J, *Design and Installation Details for Airport Visual Aids*, 12 February 2018
- Aeronautical Information Manual*, 13 September 2018
- AFI 11-202 Volume 3, *General Flight Rules*, 10 August 2016
- AFI 11-401, *Aviation Management*, 10 December 2010
- AFI 13-204 Volume 3, *Airfield Operations Procedures and Programs*, 1 September 2010
- AFI 13-213, *Airfield Driving*, 1 June 2011
- AFI 21-101, *Aircraft and Equipment Maintenance Management*, 21 May 2015
- AFI 33-360, *Publications and Forms Management*, 1 December 2015
- AFI 48-127, *Occupational Noise and Hearing Conservation Program*, 26 February 2016
- (Added-AETC)** AFMAN 33-363, *Management of Records*, 01 March 2008
- AFMAN 91-203, *Air Force Occupational Safety, Fire, and Health Standards*, 11 December 2018
- FAA-H-8083-25B, *Pilot's Handbook of Aeronautical Knowledge*, 2016
- International Civil Aviation Organization (ICAO) Doc 9476-AN/927, *Manual of Surface Movement Guidance Control Systems (SMGCS)*, 1986
- ICAO Annex 2, *Rules of the Air*, July 2005
- ICAO Annex 14 Volume 1, *Aerodrome Design and Operations*, July 2016
- The Air Almanac 2018*, 2017
- Order JO 7110.65X, *Air Traffic Control*, 12 October 2017
- UFC 3-260-01, *Airfield and Heliport Planning and Design*, 17 November 2008
- UFC 3-260-04, *Airfield and Helicopter Markings*, 16 May 2018
- UFC 3-535-01, *Visual Air Navigation Facilities*, 11 April 2017

Adopted Forms

AF Form 679, *Air Force Publication Compliance Item Waiver Request/Approval*

AF Form 847, *Recommendation for Change of Publication*

Abbreviations and Acronyms

AC—Advisory Circular

ADS-B—Automatic Dependent Surveillance – Broadcast

(Added-AETC) AETC—Air Education and Training Command

AFFSA/XOF—Air Force Flight Standards Agency Flight Directives

AFRIMS—Air Force Records Information Management System

AFI—Air Force Instruction

AFMAN—Air Force Manual

CMA—Controlled Movement Area

FAA—Federal Aviation Administration

ICAO—International Civil Aviation Organization

ILS—Instrument Landing System

MAJCOM—Major Command

OPR—Office of Primary Responsibility

RDS—Records Disposition Schedule

RSA—Runway Safety Area

SMGCS—Surface Movement Guidance and Control System

UFC—Unified Facilities Criteria

Terms

Airfield—An area on land or water that is used or intended to be used for the landing and takeoff of aircraft; includes its buildings and facilities, if any. The FAA term “airport” and the ICAO term “aerodrome” may be used interchangeably with airfield for the purposes of this instruction.

Civil Twilight—The moments at which the geometric center of the Sun’s disk is at most six degrees below the horizon, published in the *Air Almanac*, converted to local time. Morning civil twilight ends at sunrise. Evening civil twilight begins at sunset.

Day—The time between sunrise and sunset, published in the *Air Almanac*, converted to local time.

Horizontal Clearance—The distance between an obstruction and the closest extremity of an aircraft as measured across the ground.

Controlled Movement Area (CMA)—The runways, taxiways, and other areas of an airfield which are utilized for taxiing, hover taxiing, air taxiing, takeoff, and landing of aircraft,

exclusive of aprons, ramps, and aircraft parking areas. Specific approval for entry onto the CMA is required at airfields with an operating control tower. The FAA term “movement area” and the ICAO term “maneuvering area” may be used interchangeably with CMA for the purposes of this instruction.

Night—The time between the end of evening civil twilight and the beginning of morning civil twilight, published in the *Air Almanac*, converted to local time.

Non-controlled Movement Area (Non-CMA)—Ramps, aprons, and parking areas not under air traffic control. Local guidance may dictate a non-air traffic control ramp authority or procedures. The FAA term “non-movement area” and the ICAO term “movement area” may be used interchangeably with non-CMA for the purposes of this instruction.

Obstruction—An existing object that violates airfield clearances. Fixed obstructions include natural and man-made features such as buildings, trees, rocks, and terrain irregularities. Mobile obstructions include parked aircraft, parked and moving vehicles, and similar equipment.

Operate—General term to describe taxi or towing operations for the purposes of this instruction.

Operational Waiver—A waiver to address airfield safety/risk considerations and operational mitigations for the design of existing airfield facilities. The Service authority who owns the airfield determines the requirements needed to safely operate on the existing facilities.

Overtake—An overtaking aircraft is an aircraft that approaches another from the rear and is unable to see the aircraft’s port or starboard navigation lights.

Right-of-way—The legal right of an aircraft to proceed with precedence over others.

Runway Safety Area (RSA)—An area surrounding the runway intended for use by aircraft in emergency situations; it is measured from the runway ends and centerline. The runway safety area may extend up to 500 feet from the runway centerline and 1,000 feet beyond the runway ends.

Sunrise and Sunset—The moments when the Sun’s upper edge touches the horizon, published in the *Air Almanac*, converted to local time. Within Alaska, the end of evening civil twilight and the beginning of morning civil twilight, as defined for each locality.

Taxi—Movement of an aircraft under its own power on the surface of an airfield.

Tow—Movement of an aircraft under the power of a ground vehicle on the surface of an airfield.

Wingtip and Tail Growth—Occurs during turns when an aircraft’s wingtip or tail describes an arc greater than its wingspan due to its geometry and the arrangement of its landing gear.

Attachment 2

AIRCRAFT MARSHALLING SIGNALS

A2.1. General. These signals are designed for use by the aircraft marshaller facing the aircraft in a position where the aircraft marshaller can best be seen by the pilot. The aircraft marshaller will have wands illuminated at night or low visibility to facilitate observation by the pilot.

Figure A2.1. Signals for All Aircraft.

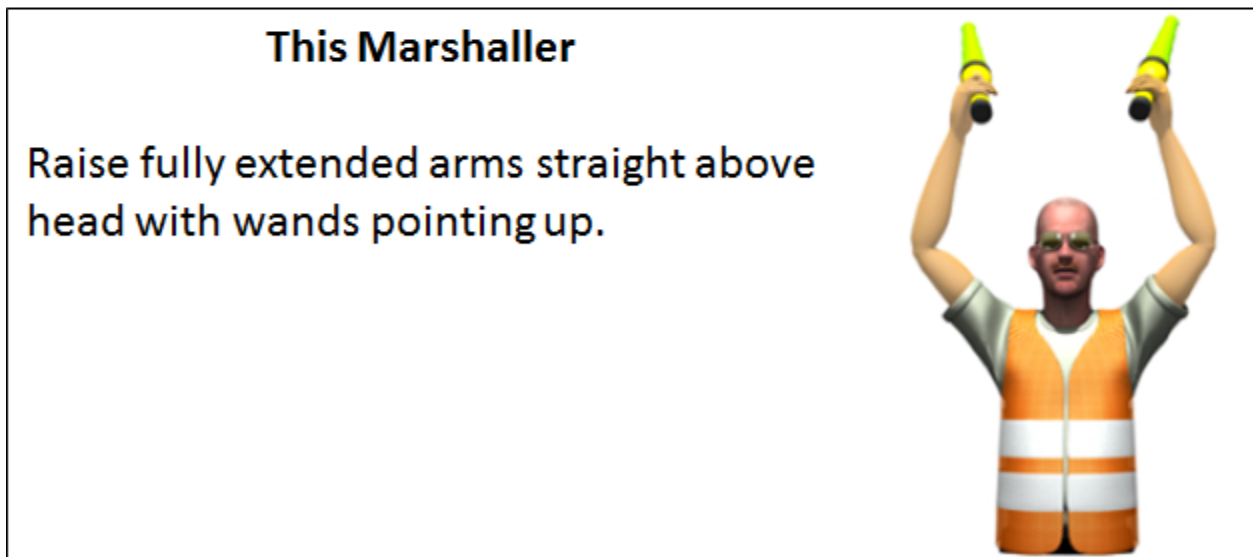
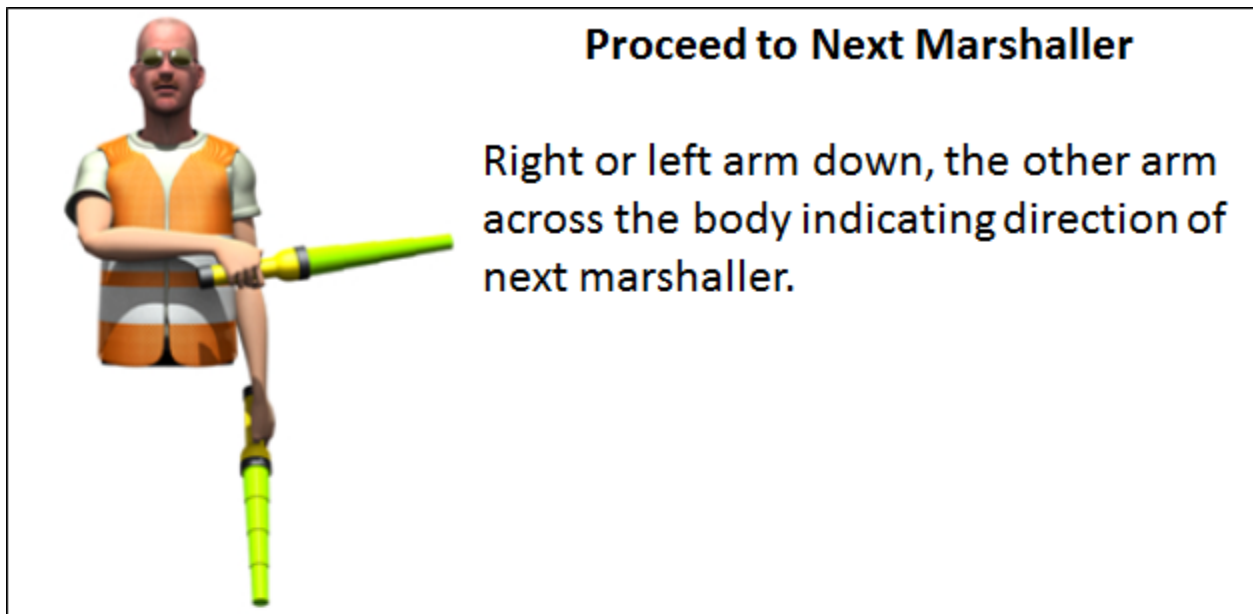

Move Forward



Bend extended arms at elbows, move hands up and down from shoulder height to head.

Turn Right / Left (from Pilot's Point of View)

Make "Move Forward" signal with one arm while extending the other downward to indicate direction of turn.

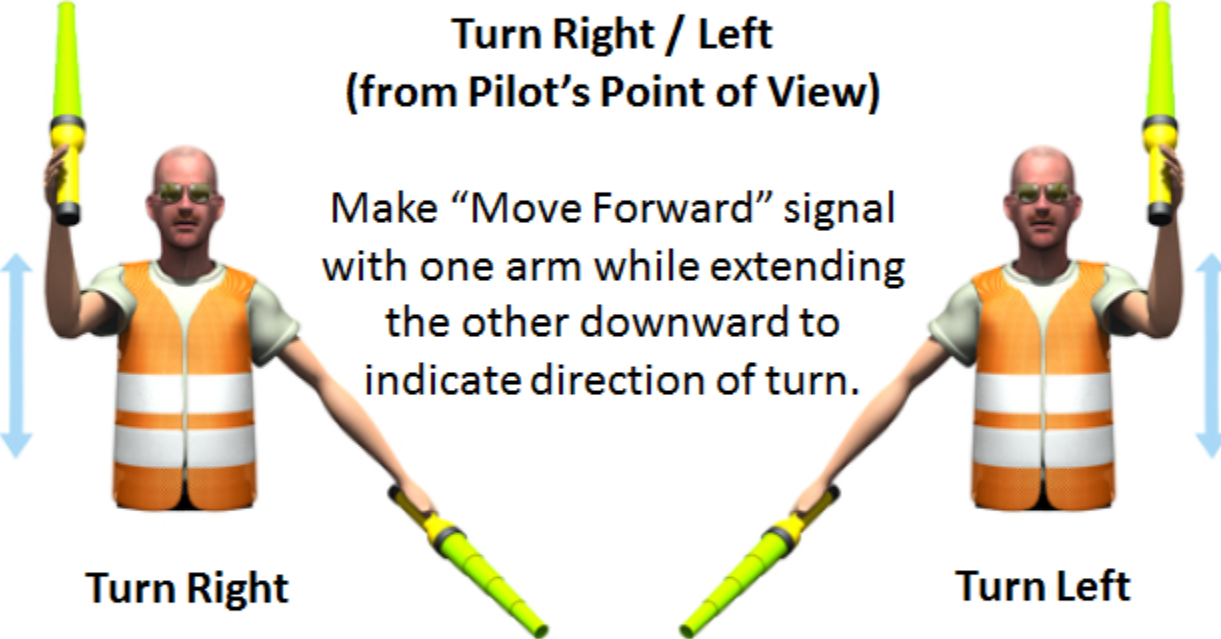

Turn Right **Turn Left**

Stop



Fully extend arms and wands at a 90-degree angle to sides, slowly move hands up until wands cross.

Move Backward

With arms down and wands toward ground, sweep arms forward and upward repeatedly to shoulder height. Do not bend arms at elbow.



Turn While Backing (from Pilot's Point of View)

Make a "Move Backward" signal with one arm while extending the other downward to indicate direction of turn.

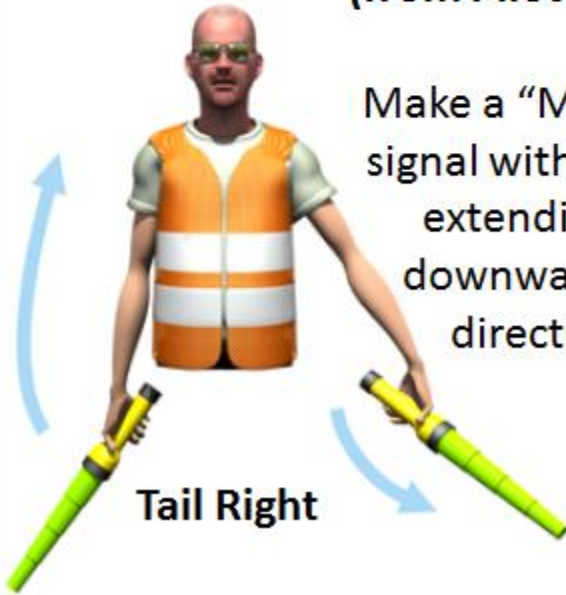

Slow Down

Extend arms down and move wands up and down from waist to knees in a “patting” gesture.



Slow Down Engine(s) on Indicated Side

With arms down and wands toward ground, wave either right or left wand up and down indicating engine(s) on left or right side respectively should be slowed down.





Start Engine(s)

Circular motion of right hand at head level with left arm pointing to engine.

**Feather / Fuel Shut Off
(Propeller Aircraft Only)**

Make a chopping motion with one hand slicing into the other.



Cut Engine(s) / Rotor

Extend arm forward of the body at shoulder level; move hand to the top left shoulder and draw hand to top of right shoulder in a slicing motion across throat.



Engine or APU Fire

Make rapid horizontal figure-eight motion with one wand, point other to source of fire.



Hot Brakes

Arms extended with forearms perpendicular to ground.



Hot Brakes – Only One Side (from Pilot's Point of View)

One arm extended with forearm perpendicular to ground, other hand points to wrist indicating aircraft side with hot brakes.



Abandon Aircraft

Marshaller first gives “cut engines” signal followed by pantomiming unfastening and throwing seat belt and shoulder straps up and off.



Request / Clearance for Personnel to Approach Aircraft

Make a beckoning motion with right hand at eye level.

Personnel Approach the Aircraft

Left hand raised vertically overhead, other hand indicates to personnel concerned and gestures towards aircraft.

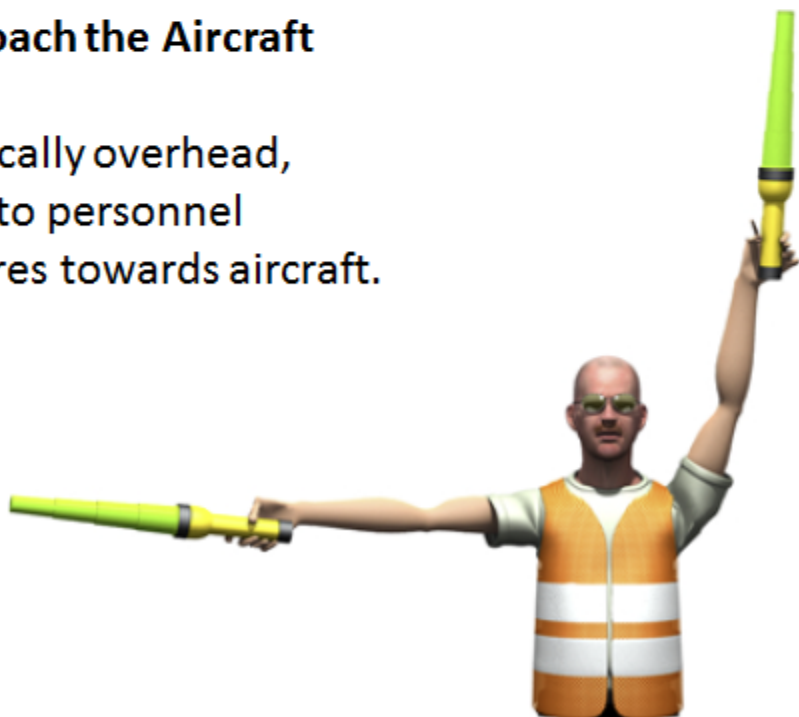



Brakes On

Arms above head with wands uncrossed then crossed.



Brakes Off

Arms above head with wands crossed then uncrossed.

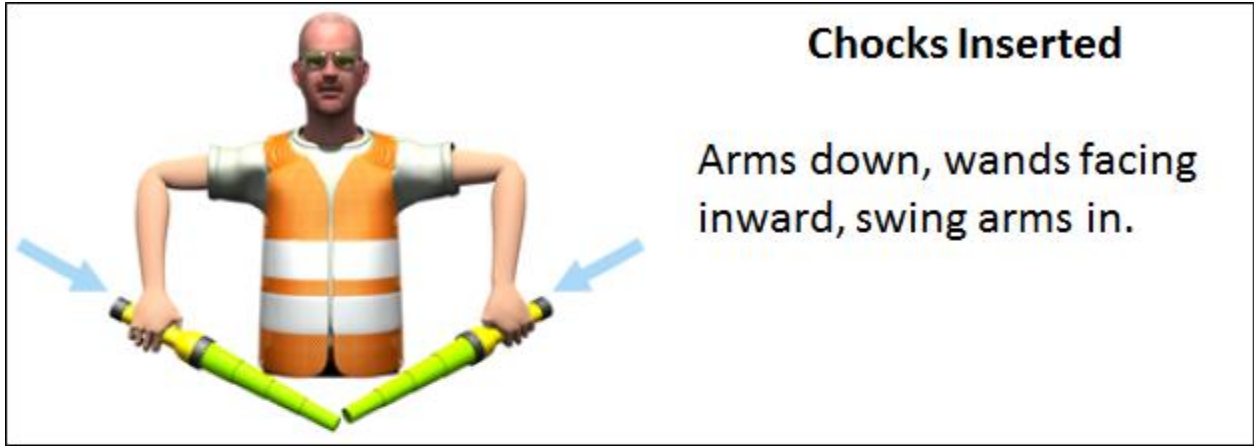

Down Locks / Landing Gear Pins Installed

Arms above head, right wand held horizontally across left wrist.



Down Locks / Landing Gear Pins Removed

Arms and wands start in “installed” position, then swing right wand up.





Lower Wing Flaps or Flaps Are Extended

Hands in front, wands together, then opened vertically from the wrist.

Raise Wing Flaps or Flaps Are Retracted

Hands in front, wands open vertically from the wrists, then suddenly closed.



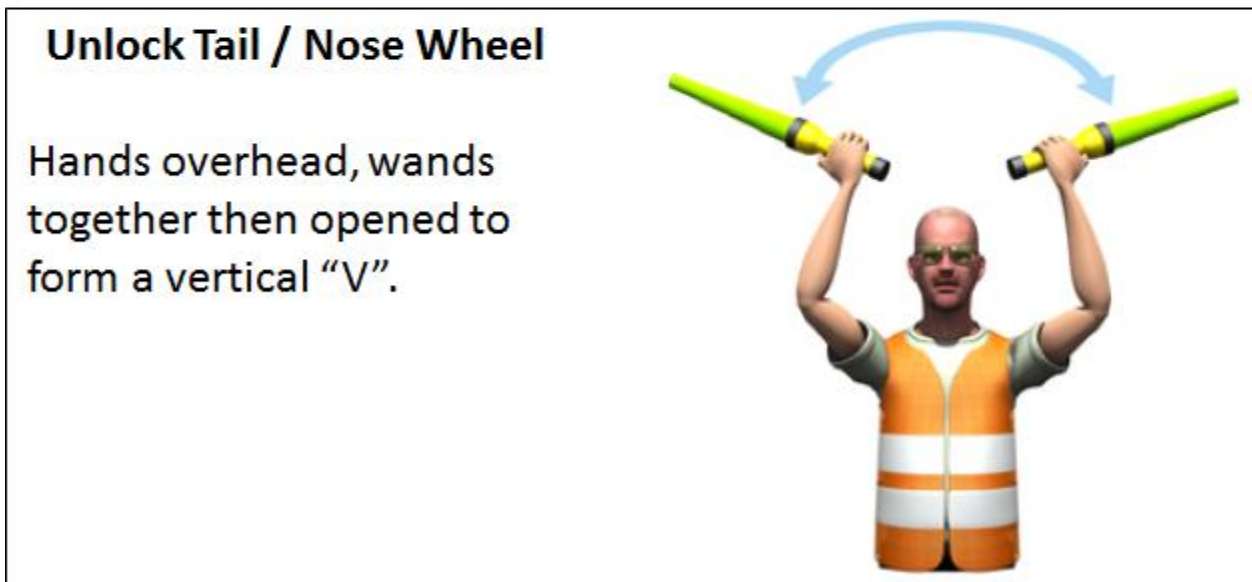

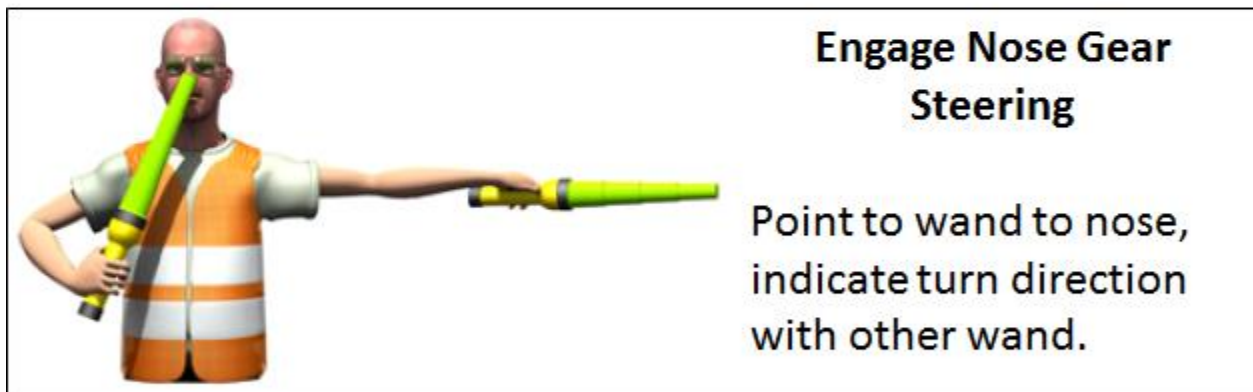
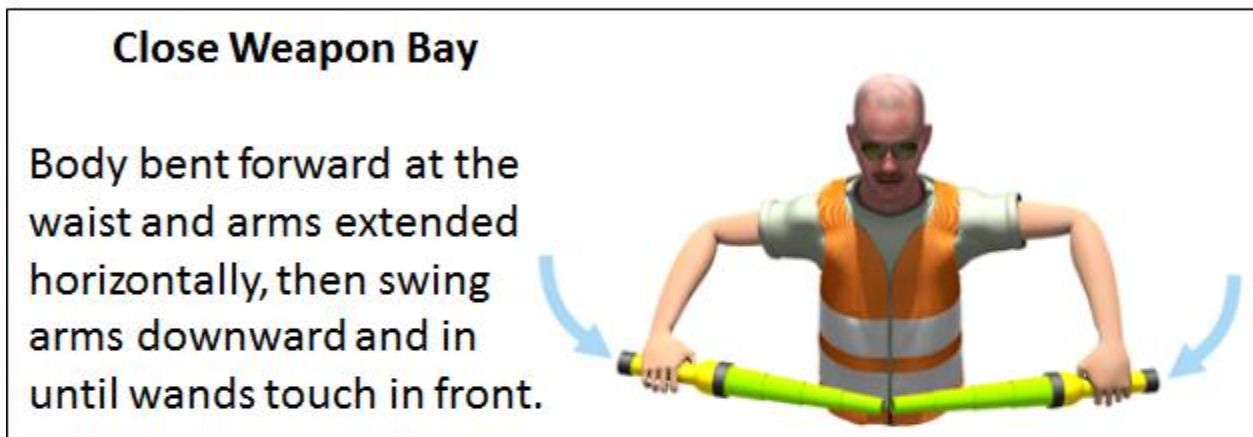
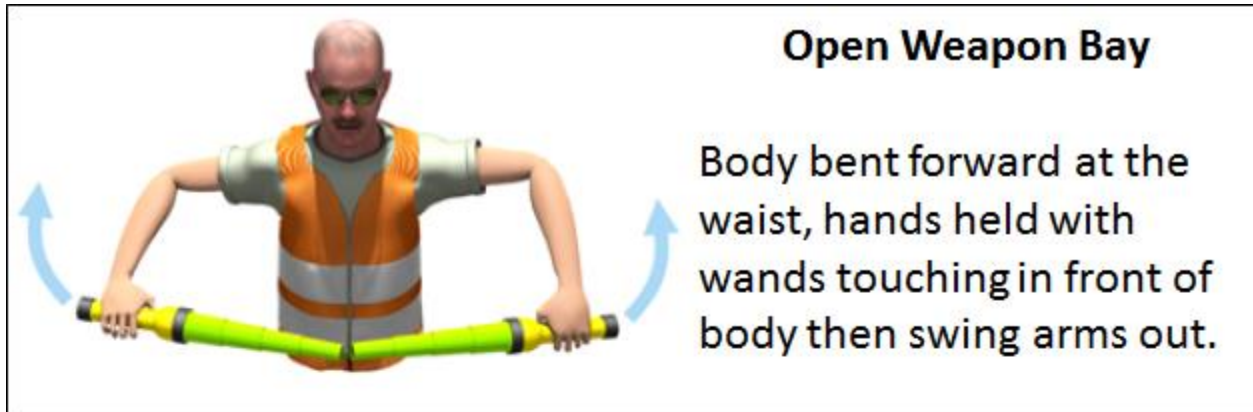

Fold Wings / Helicopter Blades / Sweep Wings Aft

Arms straight out at sides, then swept forward and hugged around shoulders.



Spread Wings / Helicopter Blades / Sweep Wings Forward

Arms hugged around shoulders, then swept straight out to the sides.



Lock Wings / Helicopter Blades

Right wand raised, point left wand to right elbow.



**Open Air / Speed Brakes or
Air / Speed Brakes Are Open**

Hands in front, wands held together, then opened horizontally from the wrists.



**Close Air / Speed Brakes or
Air / Speed Brakes Are Closed**

Hands in front, wands open horizontally from the wrists, then suddenly closed.



Up Tail Hook



Right hand, wand extended upward, raised suddenly to meet horizontal wand held in left hand.

Down Tail Hook

Right fist, wand extended downward, lowered suddenly to meet horizontal wand held in left hand.



Affirmative (All Clear) or Negative (Not Clear)

Right hand raised, wand pointed up or down to indicate response.



Affirmative



Negative





Auxiliary Power Unit Connected

Hands above head, left fist partially clenched, right hand moved toward left hand with first two fingers extended and inserted into circle made by fingers of the left hand.

Auxiliary Power Unit Disconnected

Hands above head, left fist partially clenched, right hand moved away from left hand, withdrawing first two fingers from circle made by fingers of the left hand.

External Starting Air Connected

Hands above head, left hand cupped, right fist fully clenched, right fist moved in direction of left hand and inserted into cup made by left hand.

External Starting Air Disconnected

Hands above head, left hand cupped, right fist moved away from left hand withdrawing fist from cup made by left hand.

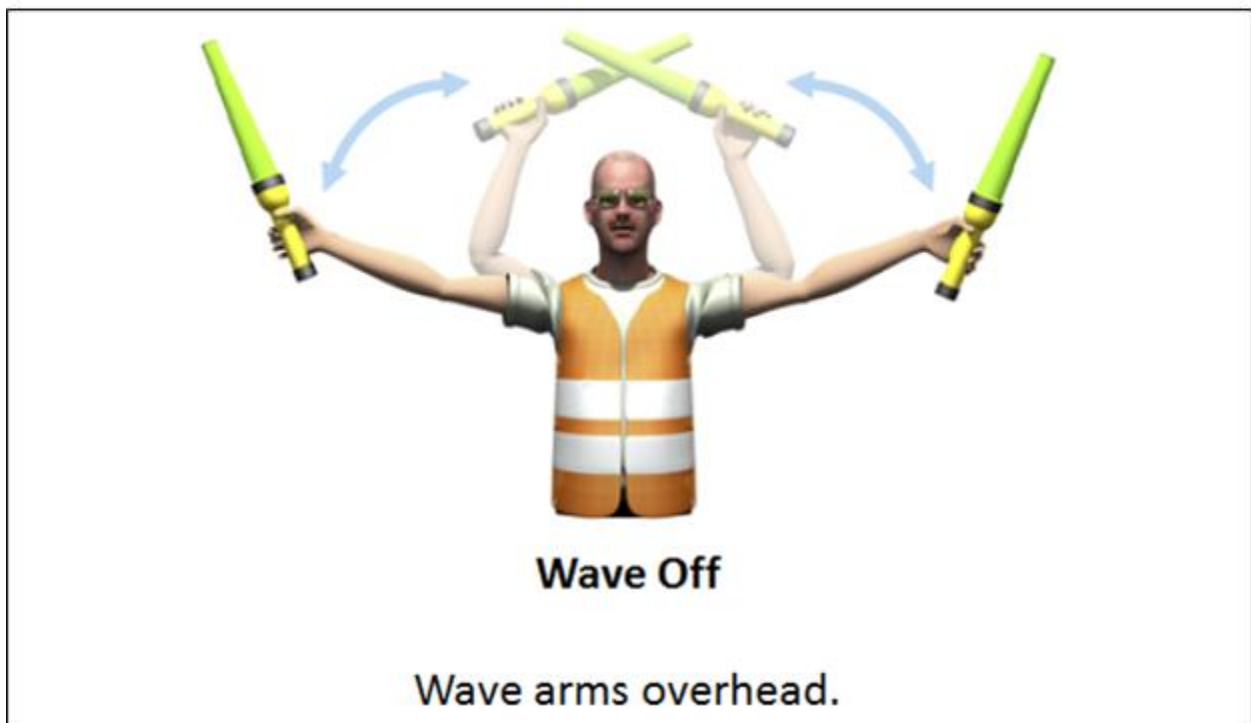
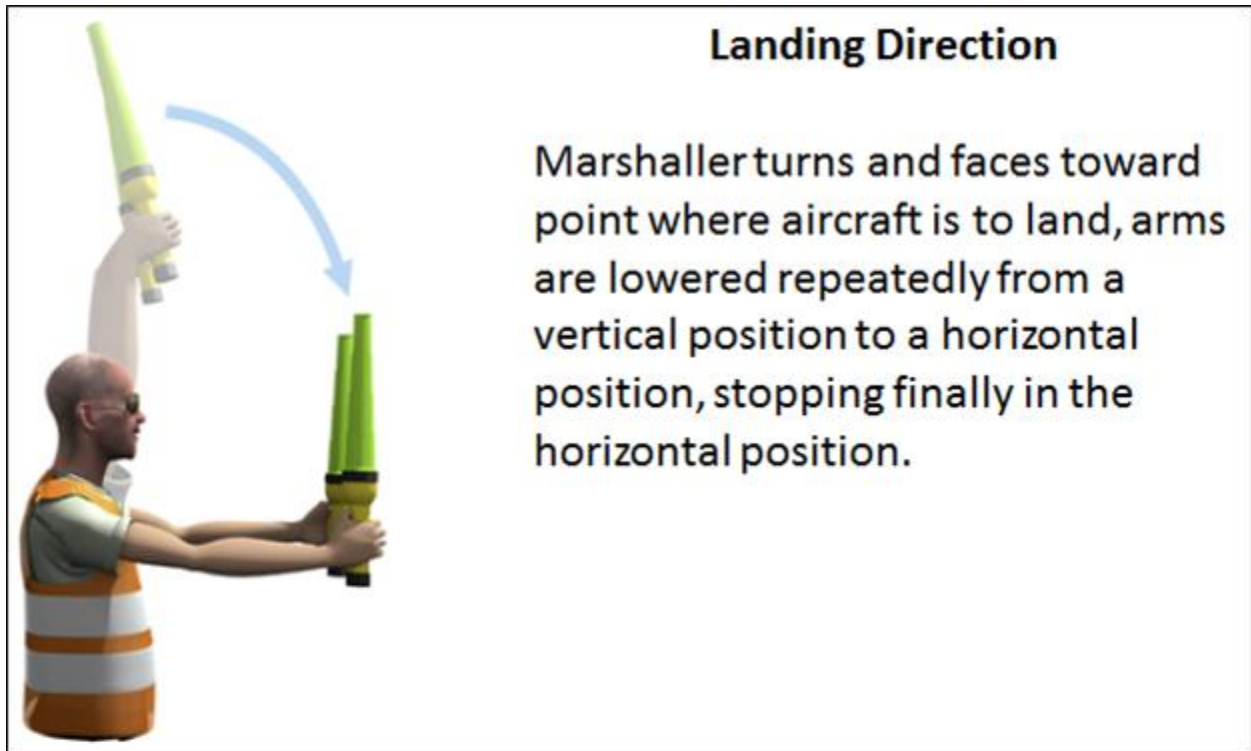

Figure A2.2. Additional Signals for Rotary Wing and Tilt Rotor Aircraft.



Vertical Movement – Move Upward

Arms extended horizontally sideways beckoning upwards with wands. Speed of movement indicates rate of ascent.



Vertical Movement – Move Downward

Arms extended horizontally sideways beckoning downwards with wands. Speed of movement indicates rate of ascent.



Horizontal Movement – Move Right

Left arm extended horizontally sideways
in direction of movement, other arm
swung over head repeatedly.



Horizontal Movement – Move Left

Right arm extended horizontally sideways
in direction of movement, other arm
swung over head repeatedly.

Release Load / Cut Cable

Left arm extended forward, move right hand in a slow slicing movement below the left hand. **Note:** Indicate “cut cable” with rapid slicing movement.



Load Not Released



Hold left wand across chest and right wand pointing up to the center of the left wand.

Down Cargo Hook

Hold left wand across waist and right wand pointing down to the center of the left wand, repeatedly raise and lower right wand.



Up Cargo Hook



Hold left wand across chest and right wand pointing up to the center of the left wand, repeatedly raise and lower right wand.

Winch Up

Wands horizontal in front of body at waist, raise right wand.



Winch Down

Wands horizontal in front of body at waist, lower right wand.



Wheels or Sling Load This High

Wands held parallel in front of chest. Distance between the wands indicates the height of the wheels or bottom of sling load above the ground.



Cargo Load Secure

Wands crossed at shoulder height.



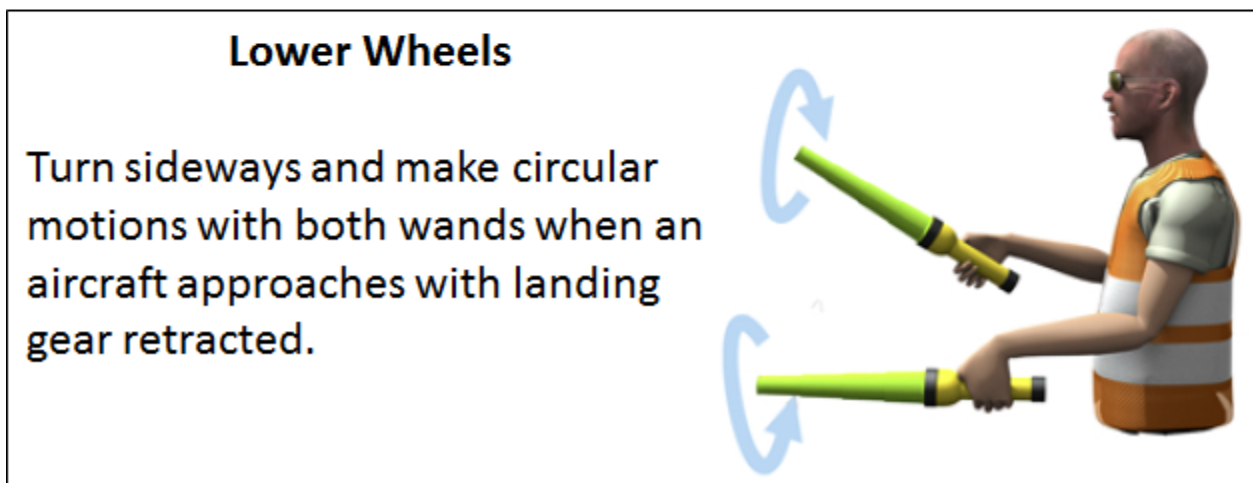
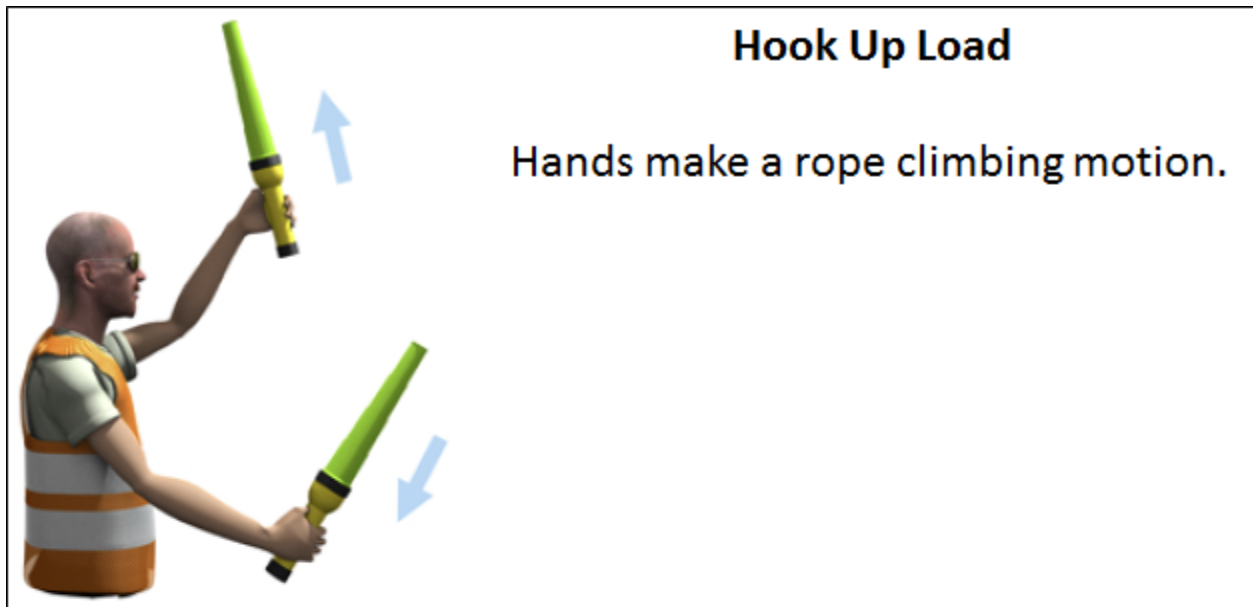

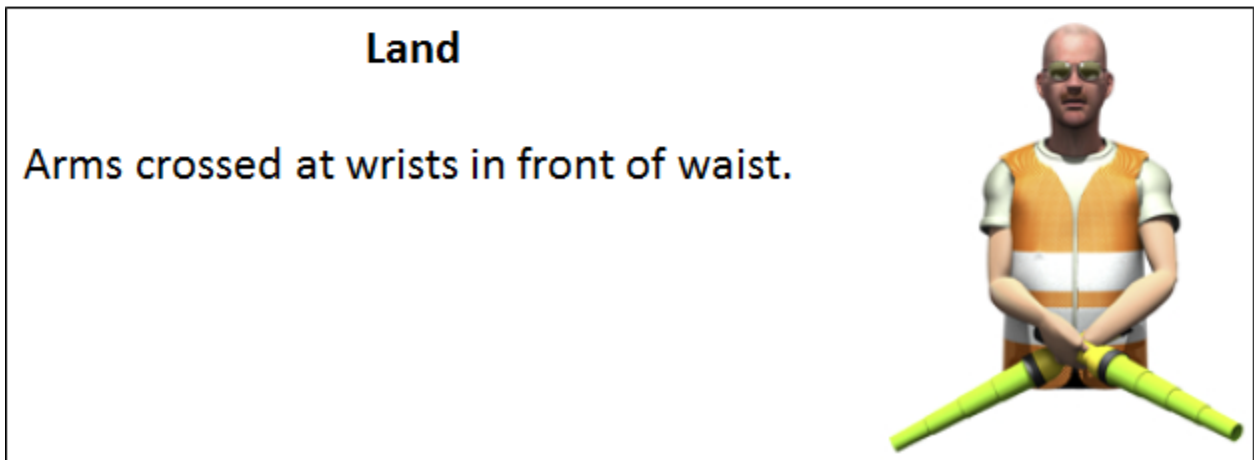
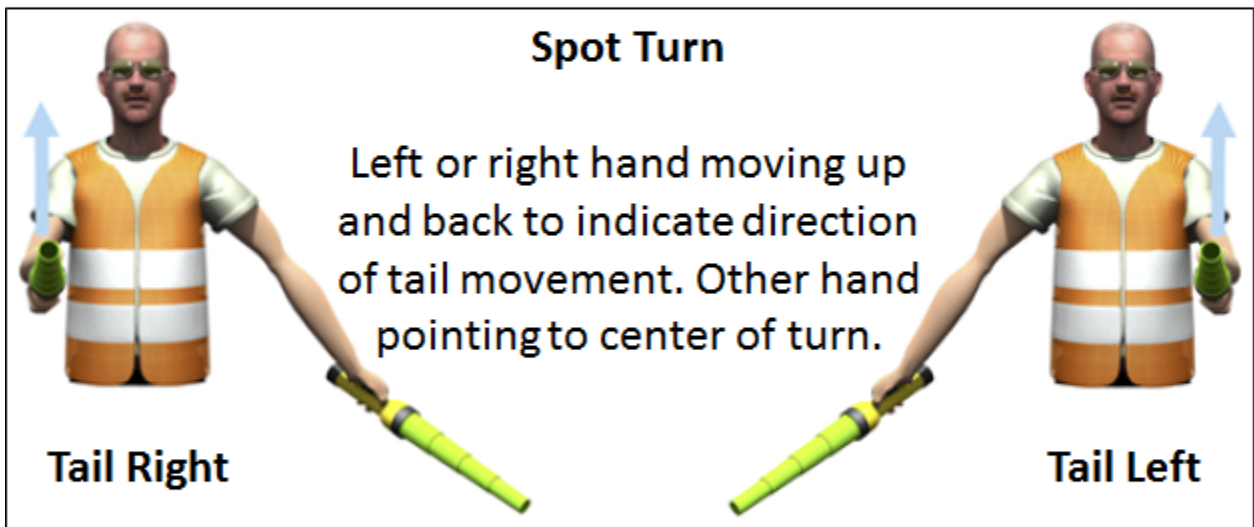
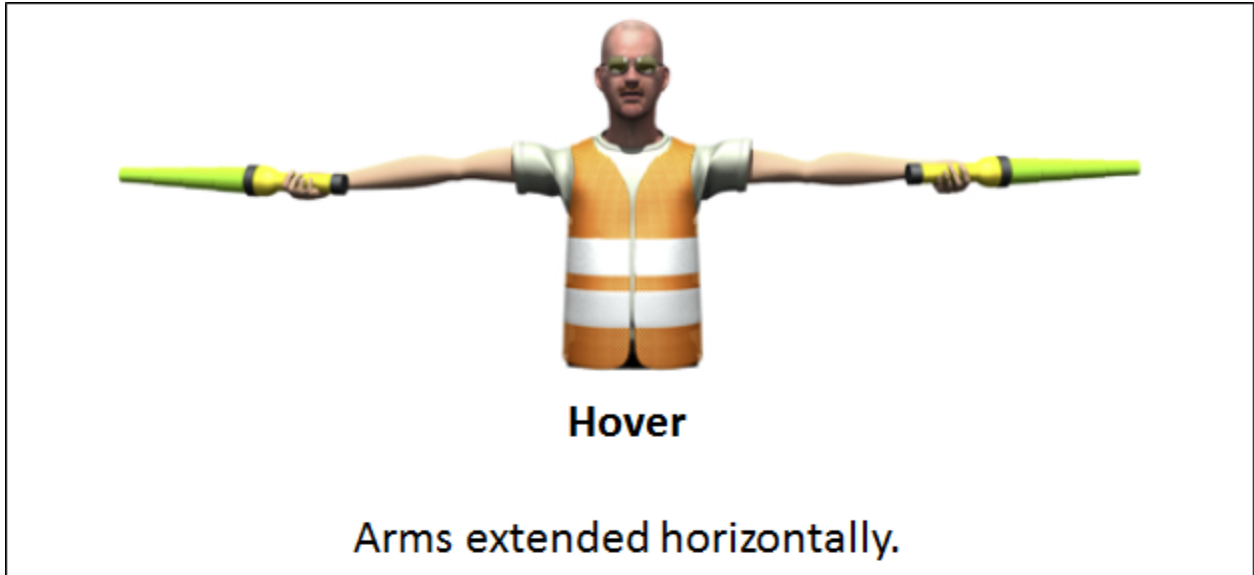

Droop Stops Out

Hands above head level,
wands pointing out.



Droop Stops In

Hands above head level,
wands pointing in.



Remove Blade Tie-Downs

Left hand above head, right hand pointing
to individual tie-downs for removal.

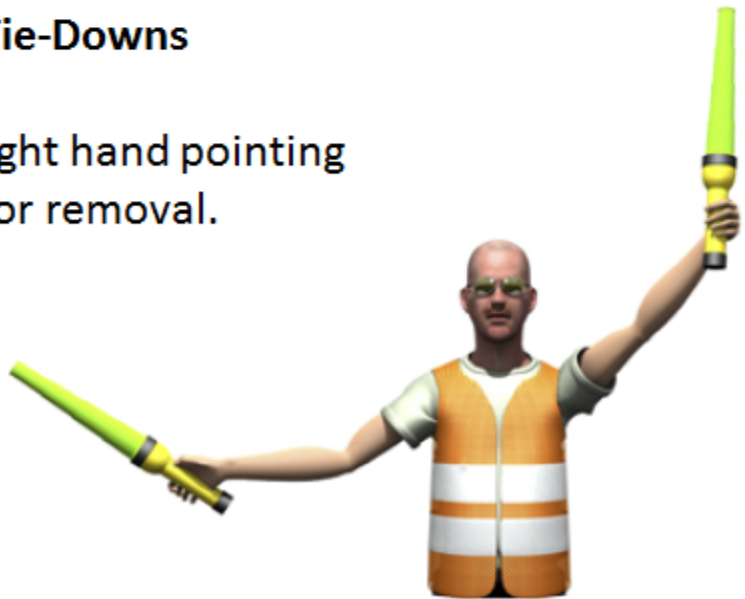

Takeoff This Way (at Pilot's Discretion)

Left wand behind back, right wand makes circular motion above head and points toward takeoff direction.

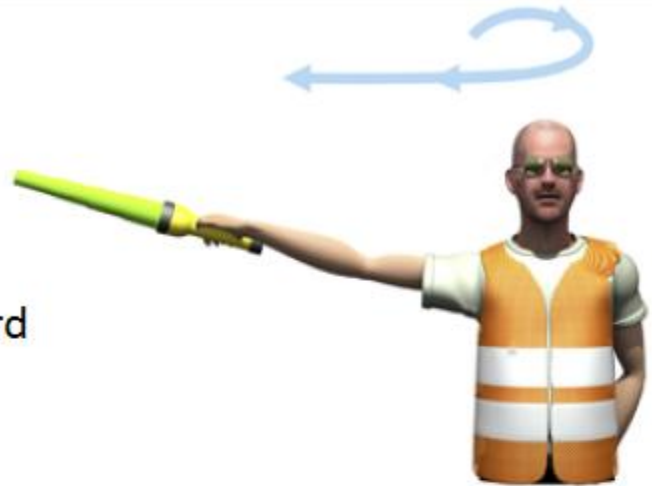

Engage Rotors

Left wand down, right wand makes circular motion above head.



