

**BY ORDER OF THE COMMANDER  
910TH AIRLIFT WING (AFRC)**



**DEPARTMENT OF THE AIR FORCE  
INSTRUCTION 31-218  
Supplement**

**26 February 2024**

**Security**

**MOTOR VEHICLE TRAFFIC  
SUPERVISION**

**COMPLIANCE WITH THIS PUBLICATION IS MANDATORY**

---

**ACCESSIBILITY:** Publications and forms are available on the e-Publishing website at [www.e-publishing.af.mil](http://www.e-publishing.af.mil) for downloading or ordering.

**RELEASABILITY:** There are no releasability restrictions on this publication.

---

OPR: 910 SFS/S5

Certified by: 910 SFS/CC  
(Capt. Robert R. Reader)

Supersedes: AFI 31-218\_910awsup  
06 November 2019

Pages: 32

This supplement implements Department of the Air Force Instruction (DAFI) 31-218 *Motor Vehicle Traffic Supervision*, current certified 10 December 2021, 31-1 *Air Force Policy Directive (AFPD)*, DAFI 31-101 *Integrated Defense*, and AFMAN 31-116 *Air Force Motor Vehicle Traffic Supervision*, DAFI 91-207 *The US Air Force Traffic Safety Program*. Compliance with this instruction is mandatory and applies to military and civilian personnel operating motor vehicles on Youngstown Air Reserve Station (YARS). It assigns responsibilities and establishes procedures for motor vehicle traffic supervision on YARS. This includes, but is not limited to granting, suspending, or revoking the privilege to operate a privately owned vehicle, snowmobiles, all-terrain vehicles (ATVs), bicycles, and motorcycles. Procedures apply to driver performance records; traffic supervision; and vehicle impoundment processes. The instruction includes a traffic system, point system, and legal consequences for violations. **NOTE:** All traffic laws of the State of Ohio apply at Youngstown Air Reserve Station. Ensure all records generated as a result of processes prescribed in this publication adhere to AFI 33-322, *Records Management and Information Governance Program*, and are disposed in accordance with (IAW) the Air Force Records Disposition Schedule, located in the Air Force Records Information Management System. Refer recommended changes and questions about this publication to the office of primary responsibility (OPR) using the DAF Form 847, *Recommendation for Change of Publication*; route DAF Forms 847 from the field through the appropriate functional chain of command. This publication may be supplemented at any level, but all supplements must be routed to the OPR of this publication for coordination prior to certification and approval. The authorities to waive wing, unit, delta, or garrison-level requirements in this publication are identified with a Tier (“T-0, T-1, T-2, T-3”) number following the compliance statement. Submit requests for waivers through the chain of command to the appropriate Tier waiver approval authority, or alternately, to the publication OPR for non-tiered compliance items. The use of the name or mark of any specific manufacturer, commercial product, commodity, or service in this publication does not imply endorsement by the Department of the Air Force.

***SUMMARY OF CHANGES:*** This instruction has been completely revised. A full review of this instruction is required. Significant changes include formatting, removal of non-essential acronyms, deletion of information already stated in other governing directives, removal of several compliance terms/statements, adding points for non-moving violations as derived from AFMAN 31-116

Chapter 1: PROGRAM MANAGEMENT.....	3
Chapter 2: DRIVING PRIVILEGES.....	4
Chapter 3: MOTOR VEHICLE REGISTRATION.....	6
Chapter 4: TRAFFIC PLANNING AND CODES.....	10
Chapter 5: AUTOMATED VEHICLES ON AIR FORCE INSTALLATIONS.....	14
Chapter 6: HEADPHONES, EARPHONES, AND CELLULAR PHONES.....	16
Chapter 7: RESTRAINT SYSTEM.....	16
Chapter 8: SPEED MEASURING DEVICES.....	16
Chapter 9: TRAFFIC ACCIDENT INVESTIGATION.....	20
Chapter 10: MAJOR TRAFFIC ACCIDENT INVESTIGATION REPORTS.....	21
Chapter 11: TRAFFIC VIOLATION REPORTS.....	21
Chapter 12: STANDARDS & PROCEDURES FOR PROCESSING INTOXICATED DRIVERS.....	22
Chapter 13: DETECTION, APPREHENSION AND TESTING OF INTOXICATED DRIVERS.....	22
Chapter 14: OFF INSTALLATION TRAFFIC ACTIVITIES.....	22
Chapter 15: COMPLIANCE WITH LOCAL AND STATE LAWS.....	22
Chapter 16: DRIVING RECORDS AND TRAFFIC POINT SYSTEM.....	23
<b>Attachment 1: GLOSSARY OF REFERENCES AND SUPPORTING INFORMATION.....</b>	<b>28</b>
<b>Attachment 2: DEPLOYED/TDY PARKING PERMIT (PART 1).....</b>	<b>30</b>
<b>Attachment 3: DEPLOYED/TDY PARKING PERMIT (PART 2).....</b>	<b>31</b>
<b>Attachment 4: DEPLOYED/TDY PARKING PERMIT (PART 3).....</b>	<b>32</b>
<b>Attachment 5: MINOR VEHICLE ACCIDENT WORKSHEET.....</b>	<b>33</b>

**1. PROGRAM MANAGEMENT.** This program implements policy, assigns responsibilities, and establishes procedures for motor vehicle traffic supervision on the installation.

1.1. This includes, but is not limited to:

1.1.1. Granting, suspending, or revoking the privilege to operate a privately owned vehicle (POV).

1.1.2. Administration of driver performance records.

1.1.3. Police traffic supervision. The base Defense Force Commander (DFC) can modify these policies and procedures when traffic operations under military supervision necessitate specific measures to meet mission unique requirements or to protect public safety. Safe and efficient movement of personnel and vehicles is the objective of every traffic control program. Program goals should focus on ways to reduce traffic-related deaths, injuries, and property damage.

## **1.2. Responsibilities.**

1.2.1. Installation Commander (AW/CC). Establishes and manages the installation traffic supervision program. The facility/installation Commander has broad authority to regulate the movement of traffic and personnel on the installation. The Commander develops local procedures to ensure safe pedestrian and vehicle traffic. To meet goals and objectives, the Commander integrates safety, engineering, legal, and law enforcement resources into the traffic review and planning process.

1.2.2. Defense Force Commander (DFC). The DFC, also known as the Security Forces commander, is the commander's principal advisor on issues pertaining to the safe movement of personnel and traffic. The DFC exercises staff responsibility for directing, regulating, and controlling traffic, and enforcing installation rules pertaining to traffic control.

1.2.3. Installation Safety Officer (ISO). The facility/installation Safety Officer develops traffic accident prevention initiatives in support of the traffic safety program. The safety officer also helps the DFC and other agencies with accident and incident investigation.

1.2.4. Installation Base Civil Engineer (BCE). The BCE plans, designs, constructs, and maintains streets highways and abutting lands. CE select, determine appropriate design, procure, construct, install, and maintain permanent traffic and parking control devices in coordination with the DFC and installation safety officer.

**1.3. Delegation of Authority.** The Installation Commander can delegate authority under this program to the Mission Support Group Commander (MSG/CC), or other appropriate official, in writing. Those selected for delegation must not occupy a law enforcement, investigative, or other position which might lead to a conflict of interest or the appearance of such conflict during their administration of the motor vehicle traffic supervision program. The Installation Commander must coordinate the letter of delegation through the installation Staff Judge Advocate.

## 2. DRIVING PRIVILEGES.

### 2.1. Requirements for driving privileges.

2.1.1. Driving a government owned vehicle (GOV) or privately owned vehicle (POV) on the installation is a privilege granted by the Installation Commander. If you accept that privilege, you must comply with the laws and instructions governing motor vehicle operation and registration on the installation. Consequently, everyone operating a motor vehicle on the installation must produce, upon request from security forces the following:

2.1.1.1. Proof of ownership or registration if required by the issuing authority.

2.1.1.2. A valid state motor vehicle operator license and AF Form (AF) 2293, US Air Force Motor Vehicle Operator's Identification Card supported by a US Armed Forces Identification Card. Locally generated Defense Biometrics Identification card (DBIDS) or Common Access Card (CAC) is acceptable identification media for civilian personnel and contractors.

2.1.1.3. Proof of current vehicle insurance.

**2.2. Stopping and Inspecting Personnel or Vehicles.** Security forces may stop vehicles on military installations based on the Installation Commander's authority. The following principles govern the stopping of motor vehicles:

2.2.1. DAFI 31-101, *Integrated Defense*, and DAFI 31-145, *Antiterrorism*, local command instructions, and policies established by the commander will detail stop, inspection, search, and impoundment of motor vehicles at the Installation entry points and in Air Force Restricted Areas.

2.2.2. On-base traffic stops and inspections (other than at Installation Access Control Points (IACP) and Restricted Areas) of POVs is authorized when there is a reasonable basis to believe it is necessary to enforce a traffic regulation or when there is suspicion of criminal activity.

**2.3. Implied Consent to Blood, Breath, or Urine Tests.** Drivers give consent to evidential tests for alcohol or other drug content of their blood, breath, and/or urine as a condition of accepting installation driving privileges. This consent applies when lawfully detained, apprehended, or cited for an impaired driving offense committed while driving or in physical control of a motor vehicle on the installation.

**2.4. Implied Consent to Vehicle Impoundment.** As a condition of accepting installation driving privileges, drivers must give their consent for the removal and temporary impoundment of their POV. To impound a vehicle will be made by the installation commander or designee, IAW paragraph 3.6 of this publication.

2.4.1. Drivers also agree to reimburse an authorized agency or contractor for the cost of towing, storage, and disposal should a need arise to remove or impound their motor vehicle because of a situation described above.

**2.5. Suspension or Revocation of Driving Privileges.** For lawful reasons, both related and unrelated to traffic violations or safe vehicle operations, the Installation Commander will follow administrative due process established and published in DAFI31-218(I) for determination and/or execution of suspension/revocation of driving privileges.

### 2.5.1. Suspensions

2.5.1.1. The Installation Commander may suspend driving privileges for serious violations or when lesser measures fail to improve a driver's performance. The commander may also suspend or revoke licenses for up to 12 months if a driver continually violates installation parking standards, or habitually violates other standards considered non-moving in nature. (i.e., performing unauthorized repair; failure to register or insure vehicles; unauthorized modifications or alterations; failure to maintain safety standards, etc.).

2.5.1.2. The Installation Commander has discretionary authority and may withdraw anyone's authorization to operate a GOV or POV on the installation.

2.5.2. Revocations. The Installation Commander will immediately revoke driving privileges for a period of not less than one year in the following circumstances:

2.5.2.1. A person is lawfully detained for intoxicated driving and refuses to submit to or complete tests to measure blood alcohol or drug content as required by law of the jurisdiction, installation traffic code, or this instruction.

2.5.2.2. A conviction, nonjudicial punishment, or a military or civilian administrative action resulting in the suspension or revocation of a driver's license for intoxicated driving.

2.5.2.3. When a serious incident involving a motor vehicle occurs and the Installation Commander determines revocation of driving privileges is required to preserve public safety or the good order and discipline of military personnel. Anyone with suspended or revoked privileges may petition the Installation Commander for partial or limited driving privileges.

## 2.6. Administrative Due Process for Suspensions and Revocations.

2.6.1. When considering suspending or revoking someone's driving privileges, notify that person in writing and tell them what action you are taking and the reason for it. Coordinate this notice with the installation legal office.

2.6.2. Except for incidents outlined in para. 2.5.1. and 2.5.2., do not suspend or revoke a person's driving privileges until they are notified (or a reasonable attempt made) and offered an administrative hearing. The Installation Commander determines when a suspension or revocation takes effect once making or attempting this written notice.

2.6.3. Any suspension of driving privileges will follow the administrative due process for suspensions detailed in AFI 31-218(I).

## 3. MOTOR VEHICLE POLICIES AND IDENTIFICATION.

**3.1. Identification.** Individuals who possess an appropriate federal ID or DBIDS generated ID card (YARS specific) will be granted access to the installation. Vehicles operators must possess and be prepared to show a valid state driver's license, proof of vehicle insurance, and proper vehicle registration to enter the installation.

3.1.1. POV's entering the installations are subject to search and/or inspection at all times. Random numbers are assigned each week to establish which vehicles are inspected, utilizing the Random Anti-terrorism Formula (RAM). During the inspection process, vehicles

operators will be required to show a valid state driver's license, proof of vehicle insurance, and proper vehicle registration to operate a motor vehicle on the installation.

3.1.2. Other than Trumbull County Sheriff's Office/Vienna Police Department who have jurisdiction authority on YARS and may request assistance, unannounced civilian police, ambulances, or fire trucks must be checked for a need to enter the installation by verification through Emergency Control Center (ECC). Announced emergency vehicles may proceed directly on the installation after a quick cursory check.

3.1.3. Air Force Office of Special Investigations (AFOSI) vehicles are usually unmarked. AFOSI agents show their AFOSI credentials or valid DBIDS Generated ID Card to gain entry onto the installation.

**3.4. Commercial Operations.** Commercial vehicles must produce a valid Bill of Lading to the Installation Access Controller to gain entry onto the installation. The Access Controller will direct the vehicle operator to proceed to Pass and Registration at Building 102, Visitor Control Center, to get the proper clearance to enter. During the inspection process vehicles operators will be required to show a valid state driver's license, proof of vehicle insurance, provide a valid need to enter the installation and proper vehicle registration to operate a motor vehicle on the installation.

3.4.1. All commercial vehicles, regardless of size or entry time, are to be inspected in the vehicle inspection facility, building 103, prior to entering the installation. Commercial vehicles with hazardous material placards will not be inspected within the vehicle inspection facility. The inspections will take place in the open overflow lane at the Installation Access Control Point.

### **3.5. Visitor procedures.**

3.5.1. When the Pass and Registration office is staffed, all visitors will be directed to building 102. All visitors must possess and produce a valid state driver's license, proof of vehicle insurance, and proper vehicle registration. Valid International driver's licenses will be recognized and authorized for use on the installation. When pass and registration is not staffed the Installation Access Controller may issue either a DBIDS generated pass, AFJIS generated pass or an AF Forms 75, *Visitor/Vehicle Pass*, for up to a 72-hour period. Visitors/contractors who require passes for more than 72 hours will be issued a 72-hour pass by the Installation Access Controller and directed to go to Pass and ID inside Bldg. 102, on the business day to

**3.6. Standards for Impoundment.** The on-duty SF Flight Chief, or above, will determine when the vehicle will be driven or moved without owner's consent if the owner cannot be contacted or the owner refuses and conditions in AFI 31-218 are present.

3.6.1. A vehicle should not be impounded unless it interferes with traffic, threatens public safety or convenience, is involved in criminal activity, contains evidence of criminal activity, or is stolen or abandoned.

3.6.2. The impoundment of vehicles is inappropriate if other reasonable alternatives exist. When possible, attempt to locate the owner of the POV and have the vehicle removed. If

reasonably feasible, allow another responsible person to drive or tow the POV, if they have provided proof of permission from the owner, operator, or person empowered to control the vehicle. However, in such cases, Security Forces (or towing contractor) is not responsible for safeguarding the vehicle. Impounding of POVs is justified when any of the following conditions exist:

- 3.6.2.1. The vehicle is illegally parked.
  - 3.6.2.2. On a street or is double-parked and interferes with the orderly flow of traffic.
  - 3.6.2.3. On a sidewalk, within an intersection, on a crosswalk, in a fire lane, or is blocking a driveway so that the vehicle interferes with operations or creates a safety hazard to other roadway users or the general public.
  - 3.6.2.4. When blocking an emergency exit door of any public place.
  - 3.6.2.5. In a “tow-away” zone that is so marked with signs.
  - 3.6.2.6. When left unattended or abandoned in or adjacent to a Restricted or Controlled area.
  - 3.6.2.7. The vehicle interferes with or engages in one of the following.
    - 3.6.2.7.1. Street cleaning or snow removal operations after attempts to contact the owner fail.
    - 3.6.2.7.2. Emergency operations during a natural disaster, fire, or other emergency
  - 3.6.2.8. The vehicle was used in a crime or contains evidence of criminal activity.
  - 3.6.2.9. The owner or person in charge of the vehicle is apprehended and therefore unable (or unwilling) to arrange removal of the vehicle.
  - 3.6.2.10. The POV is mechanically defective and is a menace to others using the public roadways.
  - 3.6.2.11. The POV is disabled by a traffic accident and the operator is unavailable or physically incapable of having the vehicle towed to a place of safety for storage or safekeeping.
  - 3.6.2.12. Law enforcement personnel reasonably believe the vehicle is abandoned.
  - 3.6.2.13. When a licensed driver is absent from the scene
- 3.6.3. Towing, Storage, and Impounding:
- 3.6.4.1. Procedures for Impoundment:
    - 3.6.4.1.1. Unattended POVs:
      - 3.6.4.1.1.1. Conspicuously place DD Form 2507, *Abandoned Vehicle Notice* (See DODD 5525.4), on POVs considered abandoned or improperly unattended. Document this action with an entry in the security forces blotter.

3.6.4.1.1.2. Allow the owner three days (72 hours) from the date the POV is tagged to remove the vehicle, except for cases where the vehicle is interfering with or impeding military operations, creating a safety hazard, disabled by incident, or left unattended in a restricted or controlled area. Security Forces is authorized to have the vehicle impounded if not moved within the allotted time.

3.6.4.1.1.3. IAW DAFI 31-218, After the vehicle is removed, Security Forces completes the DD Form 2506, *Vehicle Impoundment Report* (See DODD 5525.4), as a record of action taken.

3.6.4.1.1.4. Security Forces will forward DD Form 2507, *Notice of Vehicle Impoundment* (See DODD 5525.4), by certified mail to the address of the last known owner of the vehicle to advise the owner of the impoundment action and request information concerning the owner's intentions concerning the vehicle.

3.6.4.2. Stolen POVs or vehicles involved in criminal activity:

3.6.4.2.1. Release recovered stolen POVs to the registered owner, unless held for evidentiary purposes, or to the law enforcement agency reporting the vehicle stolen, as appropriate.

3.6.4.2.2. At times, civilian law enforcement or civilian government agencies will request the Air Force impound an on-base vehicle for reasons not related to military issues. Staff such requests through the Staff Judge Advocate (SJA) and DFC. When appropriate, comply and support such requests and impound the vehicle for a reasonable period. Release the vehicle if civil authorities do not take custody of the vehicle within a reasonable period as determined by the Installation Commander.

3.6.5. Search Incident to Impoundment Based on Criminal Activity: Search of a POV in conjunction with impoundment based on criminal activity will likely occur in one of the following situations:

3.6.5.1. The owner or operator is not present. This situation could arise during traffic and crime-related impoundments. Do not search the vehicle unless evidence or contraband is in plain view or is readily discernible on the outside as evidence of criminal activity. When in doubt, obtain proper search authority before searching.

3.6.5.2. The owner or operator is present. This situation can occur during a traffic or criminal incident or if the owner is apprehended for a crime or serious traffic violation and sufficient probable cause exists to seize the vehicle. In some cases, the operator is present but is unwilling, incapacitated, or otherwise unable to make adequate arrangements to safeguard the vehicle. As a general rule, you may search vehicle without search authority when there is reasonable danger to Security Forces or public, there is a risk of destruction of evidence, or the search is reasonable under rules governing search incident to apprehension.

3.6.6. Disposition of Vehicles After Impoundment:

3.6.6.1. 910th Security Forces will not hold a vehicle after impoundment. Vienna Police Department or Trumbull County Sheriff's Department may hold an impounded vehicle for as long as necessary for evidentiary, law enforcement, or other legal purposes.

## 4. TRAFFIC PLANNING AND CODES

### 4.1. Traffic Planning.

4.1.1. Safe and efficient movement of traffic on the installation requires traffic supervision. A strong supervision program includes sound traffic circulation planning, supervision, and control of motor vehicle traffic. Proactive publication and enforcement of traffic laws and regulations together with timely and professional investigation of motor vehicle accidents are also important.

4.1.2. The Installation Commander develops the traffic circulation plan that provides for the safest and most efficient use of primary and secondary roads. The base traffic engineer, DFC, safety officer, and other concerned agencies develop the traffic circulation plan. Planning is usually conducted at the Environmental Safety and Occupational Health (ESOH).

### 4.2. Installation Traffic Codes.

4.2.1. The Installation Commander establishes a traffic code for operation of motor vehicles on the installation. Installation traffic codes contain the base rules of the road and will, to the degree possible conform to the code of the state of Ohio. The DFC is responsible for developing the traffic code and for ensuring it meets all local and legal requirements.

#### 4.2.2. MOTOR VEHICLE LAWS

**4.2.2.1. COMPLIANCE WITH ORDER OF SECURITY FORCES; FLEEING FROM SECURITY FORCES AFTER A SIGNAL TO STOP.** No person shall fail to comply with any lawful order or direction of any SF personnel invested with authority to direct, control, or regulate traffic. No person shall operate a motor vehicle to willfully elude or flee SF personnel after receiving a visual or audible signal to bring his/her vehicle to a stop.

**4.2.2.2. EMERGENCY VEHICLES TO PROCEED CAUTIOUSLY PAST STOP SIGN.** The driver of any emergency vehicle when responding to an emergency call, upon approaching any stop sign shall slow down as necessary for safety to traffic but may proceed cautiously past the stop sign with due regard for the safety of all persons using the street.

**4.2.2.3. EMERGENCY VEHICLES EXEMPTED FROM SPEED LIMITS.** The speed limitations do not apply to emergency vehicles or public safety vehicles when they are responding to emergency calls, are equipped with, and displaying at least one flashing, rotating, or oscillating light visible to the front of the vehicle and when the drivers thereof sound audible signals by siren, or vehicle horn. This section does not relieve the driver of an emergency vehicle from the duty to drive with due caution for the safety of all persons using the street or highway.

**4.2.2.4. LANES OF TRAVEL UPON ROADWAYS.** Upon all roadways of sufficient width, a vehicle shall be driven upon the right half of the roadway, except as follows:

4.2.2.4.1. When overtaking and passing another vehicle proceeding in the same direction or when making a left turn under rules governing such movements.

4.2.2.4.2. When an obstruction exists making it necessary to drive to the left of the center of the roadway and person doing so shall yield right of way to all vehicles traveling in the

proper direction upon the unobstructed portion of the highway within such distances as to constitute an immediate hazard.

4.2.2.4.3. When driving upon a roadway designated and posted with signs for one-way traffic.

4.2.2.4.4. This section shall not be construed as prohibiting the crossing of the centerline in making a left turn into or from a parking lot or driveway.

**4.2.2.5. VEHICLES TRAVELING IN OPPOSITE DIRECTIONS.** Operators of vehicles proceeding in opposite directions shall pass each other to the right.

**4.2.2.6. RULES FOR TURNS AT INTERSECTIONS.** The driver of a vehicle intending to turn at an intersection shall be governed by the following rules:

4.2.2.6.1. Approach for a right turn and a right turn shall be made as close as practicable to the right-hand curb or edge of the roadway.

4.2.2.6.2. At any intersection where traffic is permitted to move in both directions on each roadway entering the intersection, an approach for a left turn shall be made in that portion of the right half of the roadway nearest the center line.

**4.2.2.7. USE OF SIGNALS FOR STOPPING, TURNING, DECREASING SPEED, MOVING LEFT OR RIGHT; LIMITATIONS.** No person shall turn a vehicle or move right or left upon a roadway unless and until such person has exercised due care to ascertain that the movement can be made with reasonable safety nor without giving an appropriate signal.

4.2.2.7.1. When required, a signal of intention to turn or move right or left shall be given continuously during not less than the last one hundred feet traveled by the vehicle before turning.

4.2.2.7.2. No person shall stop or suddenly decrease speed of a vehicle without first giving an appropriate signal when there is an opportunity to give a signal. Any stop or turn signal required by this section shall be given either by means of the hand and arm or signal lights that clearly indicate to both approaching and following traffic intention to turn or move right or left.

**4.2.2.8. HAND AND ARM SIGNALS.** All signals required when given by hand and arm shall be given from the left side of the vehicle in the following manner, and such signals shall indicate as follows:

4.2.2.8.1. Left turn, hand and arm extended horizontally.

4.2.2.8.2. Right turn, hand and arm extended upward.

4.2.2.8.3. Stop or decrease speed, hand and arm extended downward.

**4.2.2.9. DRIVING IN RESPONSE TO STOP OR YIELD SIGN.** Except when directed to proceed by security forces, every driver of a vehicle approaching a stop sign shall stop at a clearly marked stop line, but if none, before entering the crosswalk on the near side of the intersection, or, if none, then at the point nearest the intersection roadway where the driver has a view of approaching traffic on the intersecting roadway before entering it. After having

stopped, the driver shall yield the right-of-way to any vehicle in the intersection or approaching on another roadway.

4.2.2.9.1. The driver of a vehicle approaching a yield sign shall slow down to a speed reasonable for existing conditions and, if required for safety to stop at clearly marked stop line, but if none, before entering the crosswalk on the near side of the intersection, or, if none, then at the point nearest the intersecting roadway where the driver shall yield the right-of-way to any vehicle in the intersection.

4.2.2.9.2. Whenever a driver is involved in a collision with a vehicle in the intersection or junction of roadways, after driving past a yield sign without stopping, the collision shall be evidence of the driver's failure to yield the right-of-way.

**4.2.2.10. ENTERING ROADWAY FROM ANY PLACE OTHER THAN ANOTHER ROADWAY; DUTY TO YIELD.** The operator of a vehicle about to enter or cross a roadway from anyplace other than another roadway shall yield the right-of-way to all traffic approaching on the roadway.

**4.2.2.11. RIGHT-OF-WAY OF EMERGENCY VEHICLES.** Upon approaching an emergency vehicle, equipped with at least one flashing, rotating or oscillating light and the driver is giving audible signal by siren, or vehicle horn, the driver of every other vehicle shall immediately drive to a position parallel to, and as close as possible to, the right edge or curb of the roadway and stop and remain in such position until the emergency vehicle has passed, except when otherwise directed by SF personnel. This section does not relieve the driver of an emergency vehicle from the duty to drive with due regard for the safety of all persons and property on the roadway.

**4.2.2.12. PEDESTRIAN YIELD—EMERGENCY VEHICLE.** Upon the immediate approach of an emergency vehicle, every pedestrian shall yield the right-of-way to the emergency vehicle.

**4.2.2.13. RIGHT-OF-WAY OF PEDESTRIAN ON CROSSWALK; LIMITATIONS.** When traffic control signals are not in place or not in operation the driver of a vehicle, shall yield the right-of-way, slowing down or stopping, if need be, so to yield, to a pedestrian crossing the roadway. No pedestrian shall suddenly leave a curb or other place of safety and walk or run into the path of a vehicle, which is so close as to constitute an immediate hazard. Whenever any vehicle is stopped at a marked crosswalk or at any unmarked crosswalk at an intersection to permit a pedestrian to cross the roadway, the driver of any other vehicle approaching from the rear shall not overtake and pass the stopped vehicle.

**4.2.2.14. PEDESTRIANS WALKING ALONG ROADWAY.** Where a sidewalk is provided, any pedestrian walking along and upon a roadway shall walk only on the sidewalk.

4.2.2.14.1. Where a sidewalk is not available, any pedestrian walking along and upon a roadway shall walk only on a shoulder, as far as practical from the edge of the roadway.

4.2.2.14.2. Where neither a sidewalk nor a shoulder is available, any pedestrian walking along and upon a roadway shall walk as near as practical to an outside edge of the roadway, and, if on a two-way roadway, shall walk only on the left side of the roadway.

**4.2.2.15. PROHIBITION AGAINST CONSUMPTION IN MOTOR VEHICLE.** No person shall consume any beer or intoxicating liquor in a motor vehicle nor have an open container of alcohol or intoxicating liquor.

**4.2.3. DOD BICYCLE SAFETY RULES.** Bicycle and tricycle (non-motorized two and three wheeled vehicles) safety rules will be applied under the generic term bicycle for this AWI.

4.2.3.1. A person operating a bicycle shall not ride other than upon the permanent and regular seat attached thereto, nor carry any other person upon such bicycle other than upon a firmly attached and regular seat thereon.

4.2.3.2. No person operating a bicycle shall carry any package, bundle, or article that prevents the driver from keeping both hands on the handlebars.

4.2.3.3. A bicycle must be equipped with a headlight and rear reflectors at a minimum, when riding the bicycle after dark.

4.2.3.4. (Added) (910 AW). All personnel (including dependents, contractors, retirees, etc.) who ride bicycles on the installation must wear an approved (i.e., American National Standards Institute [ANSI] or Snell Memorial Foundation) bicycle helmet except during duties on the flight line.

## 5. MOTORIZED VEHICLES ON AIR FORCE INSTALLATIONS

**5.1. Motorcycles, Mopeds, and Motor-Scooters.** Operators must comply with specific requirements when driving motorcycles, mopeds, motor-scooters or other two or three wheeled motorized vehicles. Refer to DAFI 91-207, *The Traffic Safety Program*, for helmet, eye, and clothing safety requirements.

5.1.1. Personal Protective Equipment (PPE) requirements as outlined in DoDI 6055.04, *DoD Motor Vehicle and Traffic Safety*, and DAFI 91-207.

5.1.2. Failure to wear the PPE or comply with licensing or operator training requirements may be considered in making line-of-duty (LOD) determinations if the injury is from such nonuse of PPE or noncompliance.

**5.2. ATV's and Snowmobiles.** An All-Terrain Vehicle (ATV) is a motorized vehicle with three or four wheels, low pressure tires, a wheelbase of 50 inches or less, an overall weight of 600 pounds or less, a handlebar for steering, and seat designed to be straddled. A snowmobile is a motorized vehicle designed to operate on snow surfaces. No snowmobiles are authorized to operate at the Youngstown Air Reserve Station.

5.2.1. Off-road vehicle operators must wear protective devices in accordance with AFI 91-207 to include knee/shin guards and padded full finger off-road vehicle gloves.

5.2.2. No passengers will ride on an ATV.

5.2.3. Any use of an ATV certified to transport munitions must comply with AFMAN 91-201, *Explosive Safety Standards*.

**5.3. Operator Safety Requirements.** When operated on the installation, in both on-and-off road modes, all Government or privately owned Motorcycles, Mopeds, Motor Scooters and ATVs must have headlights turned on at all times.

**5.4. Off-Road Vehicle Training Course.** This course provides basic riding techniques and strategies necessary for government off-road vehicle operators. Units purchasing these vehicles for official use must ensure operators complete an applicable safety course that includes hands-on training and skill and knowledge evaluations. Purchasing units must develop safety requirements for mission and tactical operational training involving motorcycles and ATVs and integrate those requirements into tactics, techniques, and training. A Specialty Vehicle Institute of America (SVIA) course completion card is proof of course completion.

5.4.1. Attendees are all people who will use ATVs for official business, on or off DoD installations. Operators must complete training before operating a government owned ATV.

5.4.2. ATV Rider's Course: This course is modeled after the MSF motorcycle safety courses. It teaches riders proper protective gear selection; riding maneuvers such as sharp turns, climbing, descending; and traveling hills and surmounting obstacles. By the end of six hours participants are ready for a supervised trail ride during which they demonstrate their skills and earn a certificate of proficiency.

### **5.5. Golf-Cart Type Vehicles (GOVERNMENT OFF-ROAD VEHICLES (GORV):**

5.5.1. AFRC recognizes that several units have purchased and used golf cart-type vehicles in lieu of such motor vehicles as small trucks and automobiles. AFRC recognizes the economics of doing so and will support the continued use and operation of cart-type vehicles within the following parameters: AFI 91-207, Paragraph 2.2.4.3. requires an RM evaluation be completed prior to operating these vehicles on the installation.

5.5.2. Carts will be operated at 25 mph or less.

5.5.3. If the cart manufacturer states that the installation of occupant restraints would void the warranty on the cart, occupant restraints will NOT be installed.

5.5.4. Obviously, occupant restraints are preferred. But if the structural construction of the vehicle will not allow the proper functioning of a restraint, the restraint will not be installed.

5.5.5. Carts will be equipped with turn signals, headlight (s), a slow-moving vehicle emblem (the universally recognized orange triangle) and windshield wiper (s).

5.5.6. If carts are operated in winter and snowdrifts present a visibility problem at intersections, a brightly colored flag or ball shall be installed atop a standard and attached to the cart of sufficient height to be seen above the drifts.

5.5.7. Individuals newly gained to a work area who are expected to operate a cart must satisfactorily demonstrate ability to operate the cart before being tasked to do so. The individual's supervisor will be responsible to ensure the individual's installation driving privileges have not been suspended/revoked and that the test is completed. (NOTE): This does NOT mean that the supervisor must conduct the test. The Supervisor may designate any competent person to administer the "skills test".

### **5.6. Electric Powered Vehicles:**

5.6.1. The DoD, USAF, AFRC, and the 910th Airlift Wing have neither mandated or installed charging stations for POVs on the installation.

5.6.2. Until charging stations are installed for use for POVs on the installation, it is against wing policy to charge an electric POV on YARS and is an offense that can lead to issuance of a motor vehicle citation. As an exception, guests renting specifically designated Fam Camp spaces may charge electric vehicles, with the approval of Outdoor Recreation.

## **6. HEADPHONES, EARPHONES, AND CELLULAR PHONES**

**6.1. Headphones and earphones.** The wearing of headphones and earphones is prohibited while driving a motor vehicle on base, except when conditions and good judgment dictate, e.g. noise hazard area. This restriction does not apply to intercom systems worn by motorcycle operators and their passengers.

**6.2. Cell phones.** Cell Phones and electronic devices will not be used on the installation while operating a POV or a GOV except for utilizing a hands-free device.

## **7. RESTRAINT SYSTEMS**

7.1. Operators and passengers of all vehicles operated on the installation must wear restraint systems. In addition, operators, and passengers of GOVs must wear restraint systems when driving or riding off the installation as well.

7.2. U.S. Department of transportation requires approved infant/child restraint devices in POVs for children 4 years old or under and not exceeding 50 pounds in weight.

7.3. Cars manufactured after model year 1966 require a manufacturer-approved restraint system meeting federal traffic safety standards.

7.4. Operators using vehicles equipped with air bags must still wear the manufacturer's primary restraint system (seat belts).

## **8. SPEED MEASURING DEVICES**

8.1. **Using speed measuring devices.** Use speed measuring devices in traffic control studies and enforcement programs. Post signs to indicate the use of speed measuring devices.

8.2. The DFC reserves the right to purchase and initiate use of approved methods and devices in the future. If speed measuring devices are used, the qualification and training standards must be sufficient for readings to be admitted as reliable evidence by both military and civil authorities. Training will be coordinated with the staff judge advocate and local prosecutors.

### **8.3. SPEED LIMITS:**

- 25 MPH on all base roads unless otherwise posted.
- 15 MPH within the flight line restricted area.
- 15 MPH when entering/exiting any installation gate.
- 5 MPH within close proximity of any aircraft/when driving inside the restricted area.
- 5 MPH when towing aircraft.
- 5 MPH in all parking lots.

### **8.4. Traffic Flow.**

8.4.1. Normal traffic flow will enter/exit the Installation Access Control Points (IACP) with the left lane for through traffic and the right lane for overflow traffic.

8.4.1.1. Traffic flow in reference to lane assignments may be changed or altered by Security Forces at any time for mission requirements and force protection conditions.

8.4.2. Exigent circumstances may require the use of Gate #2 to effectively control large volumes of traffic or special events.

8.4.3. Traffic Control Points will be established at congested locations to provide for the maximum safe and efficient use of roadways during special events. Coordination with local law enforcement agencies will also be accomplished.

8.4.4. No privately owned vehicles are permitted to drive on the flight line unless they are displaying a 910 AW flight line authorization pass issued by the 910 AW Airfield Manager office.

**8.5. Parking.** Illegal parking contributes to congestion and slows traffic on the installation. Strong enforcement of parking rules results in better use of available parking while reducing traffic accidents and hazards.

8.5.1. Definition of terms:

8.5.1.1. Fire Lane: Fire lanes are those avenues adjacent to buildings which would be used by fire protection equipment in the event of fire. Fire lanes would include the roadways adjacent to and around buildings.

8.5.1.2. Loading Zone: Loading zones are areas set aside to allow individuals to load and unload vehicles.

8.5.1.3. Dual-Block Angle Parking: A parking spot containing two concrete blocks set on an angle to guide vehicles to proper alignment in the spot when both wheels touch the blocks.

8.5.1.4. Wide-Single Block Parking: A parking spot containing one single concrete block set to guide vehicles to a proper alignment in the spot when wheels touch the block.

8.5.2. Reserved or Assigned Parking Signs used on Youngstown Air Reserve Station (YARS):

8.5.2.1. Installation Commander: 910 AW/CC will have reserved slots in various lots to enable mobility in the performance of his or her duties.

8.5.2.2. Visitor Parking: Slots will be made available in various lots for visitors to the Youngstown Air Reserve Station in all parking lots.

8.5.2.3. Military Vehicles: Slots will be made available in various lots for specific government vehicles to enable mail pick-up and delivery and other official business to be conducted.

8.5.2.4. Handicapped Parking: Spaces will be made available for handicapped persons in selected lots used by the general public and lots adjacent to the areas in which handicapped persons are working.

8.5.3. Parking lot procedures:

8.5.3.1. Lots containing dual-block angle parking:

8.5.3.1.1. Pull into right angle slots so as to place right front wheel at extreme right of near block and left front wheel against left of far block.

8.5.3.1.2. Pull into left angle slots so as to place left front wheel at extreme left of near block and right front wheel against right of far block.

8.5.3.2. Lots containing wide single blocks:

8.5.3.2.1. Align vehicles so a square attitude exists.

8.5.3.2.2. Subsequent vehicles will align with first vehicle until a row is complete.

8.5.2.2.3. The same procedure will follow when forming the next row.

8.5.3.3. Lots where no parking blocks exist:

8.5.3.3.1. Align vehicles so a square attitude exists.

8.5.3.3.2. Subsequent vehicles will align with the first vehicle until a row is complete but leaving room on both ends for vehicles to pass.

8.5.3.3.3. The same procedure will follow when forming the next row.

8.5.3.4. Prohibited Parking:

8.5.3.4.1. In a space reserved for other specified vehicle.

8.5.3.4.2. Within 15 feet of a fire hydrant, street corner or intersection.

8.5.3.4.3. Within 25 feet of a building (unless already approved for parking).

8.5.3.4.4. In a fire lane.

8.5.3.4.5. When blocking an entrance or exit to a building.

8.5.3.4.6. On a street blocking one lane of traffic.

8.5.3.4.7. On a road shoulder.

8.5.3.4.8. On grass, unless parking is designated by the Installation Commander under expanded parking conditions due to an open house, large visiting groups, and other similar events.

8.5.3.4.9. On access aprons around hangers.

8.5.3.4.10. On sidewalks and curbing.

8.5.3.4.11. In areas designated as loading zones.

8.5.3.4.12. The above prohibited parking restrictions do not apply to the Fire Department and Security Forces in that area. This is due to the response requirement in an emergency.

8.5.3.4.13. All motor vehicles parked on the installation will be properly registered and plated as prescribed by state law.

## **8.6. Reserved or Assigned Parking Areas on YARS.**

8.6.1. Installation Commander (910 AW/CC). 910 AW/CC will have reserved slots in various lots to support TDY, deployed or mobilized personnel. The Commander can suspend or revoke licenses for prolonged violations of parking standards or non-moving violations.

8.6.1.1. Extended parking (more than 72 hours) is available at the following on-base locations:

8.6.1.1.1. Deployed lot adjacent to Building 208 and behind Building 205/206.

8.6.1.1.2. Lower parking lot of Building 128 as close to Arnold Road as possible.

8.6.2. Long term parking is at the risk of the deployed/TDY member and the 910th Airlift Wing incurs no liability whatsoever for vehicles parked on base during deployment activities. Complete a deployed/TDY parking permit (attachment 2 and 3) prior to departure and submit to 910 SFS/S5P, SFS/S5A or Emergency Control Center (Building 402). Contact Unit Deployment Managers for questions.

8.6.3. Units are encouraged to stress these protocols to TDY, deployed, or mobilized personnel, ensuring adherence, and contributing to a secure environment on YARS.

**8.6. Adverse Weather.** Provisions for adverse road and weather conditions affecting this installation and its employees are contained in the base Snow and Ice Control Plan and the 910 AW Comprehensive Emergency Management Plan (CEMP) 10-2. When the situation dictates, refer to the appropriate plan for specific instructions.

**8.7. Special Events.** Due to the small size of this installation and accessibility, large events such as air shows are exceedingly difficult to manage. Parking for large events requires the use of unpaved areas of the base such as grass-covered areas and fields. Weather permitting, all available space will be used for parking. Planning and coordination for specialized events will be conducted in meetings designated for the specific event.

**8.8. Control During FPCONS.** During periods of heightened security, traffic flow will be altered to protect personnel and resources from attack. Barriers will be placed at strategic locations to impede the normal flow of traffic. Heavy equipment or jersey barriers will be placed at the Main IACP to obstruct the normal flow of traffic coming on the installation. An emergency exit, other than the Main IACP, will be designated and used in the event a terrorist act occurs on this installation. This emergency exit will be used by all nonessential personnel and secured when they are safely off the installation.

## 9. TRAFFIC ACCIDENT INVESTIGATION

**9.1. Major Vehicle Accident.** Security Forces will complete a formal investigation and AF Form 1315 within 72 hours. Additionally, notifications will be made to SFS leadership, Wing Safety, and S5 Investigations. For GOV notify CP, and fatality OSHP. Major vehicle accidents include:

9.1.1. Accidents where government vehicle and property damage exceed \$10,000.

9.1.2. Accidents involving death or injuries.

9.1.3. Damage to a POV requiring towing, and

9.1.4. Suspicious accidents that are hard to explain.

**9.2. Minor vehicle accidents.** Minor Vehicle Accidents are all other accidents that do not fall into the major vehicle accident category. As a minimum, the blotter entry will include the type of

accident, time and date, location, name, driver's license number of operators, unit (or address when a civilian not affiliated with the military), vehicle description and damage. When security Forces note an obvious violation, a citation will be issued. At no time will the blotter assign blame for an accident.

## 10. MAJOR TRAFFIC ACCIDENT INVESTIGATION REPORTS

10.1. Anyone involved in an on-base vehicle accident must immediately report the incident to the security forces control center at 609-1277/1299.

10.2. Off installation vehicle accidents involving GOVs will be reported to local authorities and 910 LRS/LGV.

10.2.1. All other off installation vehicle accidents will be reported to local authorities.

10.3. Security forces will respond to all on-base major vehicle accidents to accomplish the following:

10.3.1. Render first aid and arrange for medical assistance.

10.3.2. Protect personal property.

10.3.3. Normalize traffic.

10.3.4. Identify witnesses and personnel involved.

10.3.5. Conduct a formal investigation.

10.3.6. Take photographs.

10.4. All minor vehicle accidents require at minimum a detailed entry in the security forces blotter, documentation on the *Vehicle Accident Information Worksheet*, (Attachment 3), issue of a, *Vehicle Accident Information Exchange Sheet*, (Attachment 4), photographs of the accident and notification to the Wing Safety Office at (330) 609-1313/1088.

## 11. TRAFFIC VIOLATION REPORTS

**11.1. Traffic Violations (DD Form 1408).** The Installation Commander establishes procedures for disposing of traffic violation cases through administrative or judicial action consistent with the Uniform Code of Military Justice (UCMJ) and federal law. Additionally, forward a copy of all violation reports on military personnel and DoD civilian employees apprehended for intoxicated driving to the Substance Abuse Office, Drug and Alcohol Control. When a DD Form 1408 (Armed Forces Traffic Ticket) is used, distribute the form as follows:

11.1.1. Provide the pink copy to the violator. Whether resulting in a traffic ticket or written warning, the unit commander will counsel Military Members. Violators will have 5 days to notify Police Services of their intent to rebut the citation.

11.1.2. Forward the white copy to the service member's commander, to the commander of the family member's sponsor, or to the civilian's supervisor or employer for administrative action within the unit/organization.

11.1.3. Forward the yellow copy to the Security Forces Administration (S5P) branch for processing and tracking until the white "action copy" is returned by the unit commander, section commander, or First Sergeant. When the white copy is received, review it for action taken; annotate the information in the Air Force Justice Information System (AFJIS) and data will be tracked by S5P (Pass and Registration) in the AFJIS module,

with the moving or non-moving violation and any points assessed. File the white and yellow copies in the S5P office.

## 12. STANDARDS & PROCEDURES FOR PROCESSING INTOXICATED DRIVERS

**12.1. Policy.** As a minimum, the DFC will ensure that installation law enforcement personnel are trained to do the following:

12.1.1. Recognize signs of alcohol and other drug impairment in persons operating motor vehicles.

12.1.2. Contact local authorities and request at a minimum a field sobriety test be conducted.

12.1.3. Prepare DD Form 1920, *Alcohol Incident Report*, or other form which adequately documents sobriety testing of an individual.

## 13. DETECTION, APPREHENSION, AND TESTING OF INTOXICATED DRIVERS

**13.1. Overview.** Often, SFS personnel will detect impaired drivers by observing unusual or abnormal driving behavior. Stop these drivers and determine the cause of their unusual driving behavior. If SFS personnel have reasonable suspicion the individual in control of the vehicle is impaired, they will contact local authorities and request field sobriety tests. The DD Form 1920, *Alcohol Influence Report*, will be used in examining, interpreting, and recording results of such tests.

## 14. OFF-INSTALLATION TRAFFIC ACTIVITIES

**14.1. Overview.** Civil authorities enforce traffic laws in areas not under military control. Likewise, security forces often investigate on-base accidents and incidents of interest to local authorities. Consequently, the 910 SFS will share and exchange information with civil authorities IAW established agreements and procedures. These agreements and procedures will comply with the Privacy Act. 910 SFS/S5 will be responsible for receiving, processing, and securing of traffic and related incident reports received from other investigative agencies.

## 15. COMPLIANCE WITH LOCAL AND STATE LAWS

**15.1. Overview.** The Installation Commander must ensure drivers comply with state and local laws when operating government vehicles on or off base. Commanders coordinate with the proper civil law enforcement agency before moving government property that requires special handling or exceed legal limits such as weight, length, width, or other standards.

15.3. The Installation Commander should maintain a close liaison with civil enforcement agencies and encourage the following:

15.3.1. When possible, the prompt release of government vehicles and operators involved in accidents or incidents.

15.3.2. Prompt notice to military authorities when military or drivers of government motor vehicles are involved in traffic accidents or detained for serious violations of civil traffic laws.

15.3.3. Prompt notice of any state or local action to suspend, revoke, or restrict the driving privileges of personnel assigned to the installation.

## 16. DRIVING RECORDS AND THE TRAFFIC POINT SYSTEM

16.1. **Driving Records.** AFJIS database will be utilized to record vehicle traffic accidents, moving and parking violations, suspension or revocation actions, and traffic point assessments involving military and DoD civilian personnel, their family members, and other personnel operating motor vehicles on the installation.

**Table 16.1 Suspension/Revocation of Driving Privileges (See notes 1 and 2)**

<p><b>Assessment: 1.</b> Two-year revocation is mandatory on determination of facts by Installation Commander.</p> <p><b>Violation:</b> Driving while driver's license or installation driving privileges are under suspension or revocation.</p>
<p><b>Assessment: 2.</b> One-year revocation is mandatory on determination of facts by Installation Commander.</p> <p><b>Violation:</b> Refusal to submit to or failure to complete chemical test (implied consent).</p>
<p><b>Assessment 3.</b> One-year revocation is mandatory on conviction.</p> <p><b>Violation:</b></p> <ol style="list-style-type: none"> <li>1. Manslaughter (or negligent homicide by vehicle) resulting from the operation of a vehicle.</li> <li>2. Driving or in physical control of a motor vehicle while under the influence of intoxicating liquor 0.08% or greater.</li> <li>3. Driving a motor vehicle while under the influence of any narcotic or while under the influence of any other drug (including alcohol) to the degree rendered incapable of safe vehicle operations.</li> <li>4. Use of a motor vehicle in the commission of a felony.</li> <li>5. Fleeing the scene involving death or personal injury (hit and run).</li> <li>6. Perjury or making a false statement or affidavit under oath to responsible officials relating to the ownership or operation of motor vehicles.</li> <li>7. Unauthorized use of a motor vehicle belonging to another, when the act does not amount to a felony.</li> </ol>
<p><b>Assessment: 4. Suspension</b> for a period of six months or less or revocation for a period not to exceed one year is discretionary.</p> <p><b>Violation:</b></p> <ol style="list-style-type: none"> <li>1. Mental or physical impairment (not including alcohol or other drug use) to the degree rendered incompetent to drive.</li> <li>2. Commission of an offense in another state which, if committed on the installation, would establish grounds for suspension or revocation.</li> <li>3. Permitting an unlawful or fraudulent use of an official driver's license.</li> <li>4. Conviction of fleeing or attempting to elude a police officer.</li> <li>5. Conviction of racing on the highway.</li> <li>6. Excessive parking and other non-moving violations.</li> </ol>

### NOTES:

1. When imposing a suspension or revocation because of an off-installation offense, the effective date is the same as the date of civil conviction or the suspension or revocation date of state driving privileges. This effective date can be retroactive.

2. No points are assessed solely for revocation or suspension actions. Except for implied consent violations, base revocations on a conviction by a civilian court, military courts-martial,

nonjudicial punishment under Article 15 of the UCMJ, or a separate hearing as otherwise addressed in this instruction. If revocation for implied consent is combined with another revocation such as one year for intoxicated driving, revocations may run consecutively (total of 24 months) or concurrently (total of 12 months). Apply the Installation Commander's policy systematically and not on a case-by-case basis.

**16.2. The Traffic Point System.** The traffic point system provides a uniform administrative device to impartially judge personnel's driving performance. This system is not a disciplinary measure or a substitute for punitive action. Further, this system is not intended to interfere in any way with the reasonable exercise of the Installation Commander's prerogative to issue, suspend, revoke, deny, or reinstate installation driving privileges.

16.2.1. Point system application. The use of the point system and procedures prescribed herein are mandatory. The point system applies to civilian personnel operating government vehicles on and off the installation and to their POVs driven on-base. It applies to military personnel operating GOVs and POVs on or off the installation and to dependents, civilian employees, and all other individuals subject to this program operating POVs on the installation. Unless an individual submits a rebuttal, assess points according to the table below. Also assess points to individuals found guilty by a military or civilian court, or upon payment of fine or forfeiture of pay and allowances or posted bond or collateral.

**Table 16-2 Point Assessment for Moving Violations (See Note 1)**

<b>Violation</b>	<b>Points assessed</b>
Reckless driving (willful and wanton disregard for the safety of persons or property).	6
Owner knowingly and willfully permitting a physically impaired person to operate the owner's motor vehicle.	6
Fleeing the scene (hit and run)-property damage only.	6
Driving vehicle while impaired (blood-alcohol content more than 0.05% and less than 0.08% or lesser amount when assimilating a local or state standard.	6
Speed contests (racing).	6
Speed too fast for conditions	2
Speed too slow causing potential safety hazard.	2
Failure of operator or occupants to use available restraint system devices while moving (operator assessed points).	2
Failure to properly restrain children in a child restraint system while moving (when child is 4 years of age or younger or the weight of the child does not exceed 50 pounds), where the state uses a more stringent standard, the Air Force will assimilate the more stringent standard. See note #3	2
1 to 10 miles per hour over the posted speed limit.	3
Over 10 but not more than 15 miles per hour over the posted speed limit.	4
Over 15 but not more than 20 miles per hour over the posted speed limit.	5
Over 20 miles per hour above the posted speed limit.	6
Following too closely	4
Failure to yield the right of way to emergency vehicle	4
Failure to yield to pedestrians in designated walkway/crosswalk See note #5	3
Failure to stop for school bus or school-crossing signals.	4
Failure to obey traffic signals or traffic instructions of an enforcement officer or traffic warden, or any official regulatory traffic sign or device requiring a full stop or yield of right of way; denying entry; or requiring direction of traffic.	4
Improper passing	4
Failure to yield (no official sign involved).	4

<b>Violation</b>	<b>Points assessed</b>
Improper turning movements (no official sign involved).	3
Wearing of headphones/earphones while driving motor vehicles (two or more wheels).	3
Failure to wear an approved helmet and/or eyewear while operating or riding on a motorcycle, MOPED, or a three or four-wheel vehicle powered by a motorcycle-like engine.	3
Improper overtaking	3
Other moving violations (involving driver behavior only).	3
Operating an unsafe vehicle (see note 2)	2
Using a cell phone, without hands free device, while operating a motor vehicle	2
Operating a radar detection device to indicate the presence of speed recording instruments or to transmit simulated erroneous speed (prohibited on DoD installations). See note #4	3
Driver involved in accident is deemed responsible (only added to points assessed for specific violations).	1

**NOTES:**

1. When two or more violations are committed on a single occasion, points may be assessed for each individual violation.
2. Use this measure for other than minor vehicle safety defects or when a driver or registrant fails to correct a minor defect (for example, a burned-out headlight not replaced within the grace period on a warning ticket).
3. Applies to not using or improper use of a child restraint device, i.e., car seat, infant carrier, booster seat, belt/strap modification (when required by manufacturer) etc. Assess four points when no restraint system of any kind is used.
4. When Violation occurs within an active school zone, add 1 point
5. Installation Commander may suspend driving privileges for 1<sup>st</sup> and subsequent offense.

**Table 16-2.1 Point Assessment for Non-Moving Violations (See Note 1)**

<b>Violation</b>	<b>Points Assessed</b>
Unattended Child under 12 years of age left in vehicle. Animals are included if a danger exists to the animal.	6
Improper Registration (fraudulent tags)	4
Misuse of handicap decal. See note #2	3
Illegally parked in a designated handicap area (no decal, license, or placard displayed).	3
Unattended Vehicle (While running)	3
Abandoned Vehicle	3
Improper Parking. See note #4	2
Improper Registration (expired or unregistered)	2

**NOTES:**

1. When two or more violations are committed on a single occasion, points may be assessed for each violation.
2. When a Vehicle has a handicap decal displayed, but the occupant is not the decal or placard registrant and is not dropping off or picking up the registrant with disabilities. Also includes parking in an area designated for "Van" access only, and handicap registrant has parked another vehicle class instead.
3. When designated in local parking plan (e.g., double parked, parked in reserved parking, against the flow of traffic and those areas designated for emergency vehicles).
4. When an incident report is also accomplished, revocation of driving privileges for one year is considered by the commander. **Example:** If Children or animals were left in dangerous conditions in vehicle, e.g., in hot weather where interior temperatures may reach dangerous levels, keys left accessible to children or where conditions are deemed hazardous by a reasonable person.
5. Emergency vehicles are authorized to park in any area deemed necessary to affect a response.

**16.3. Point System Procedures.** Consult DAFI 31-118, *Security Forces Systems and Administration* for processing and rebuttal information.

16.3.1. Reports of moving traffic violations recorded on DD Form 1408 will serve as a basis for determining point assessment.

16.3.2. On receipt of DD Form 1408, *US Armed Forces Traffic Ticket*, or other military law enforcement report of a moving violation (e.g., AF Form 3545, *Incident Report*) the unit commander or designated supervisor will conduct an inquiry. The commander will take or recommend proper discipline or administrative actions.

16.3.3. Distribute citation copies and process point assessments.

16.3.4. The Installation Commander may require the following driver improvement measures as appropriate:

16.3.4.1. Advisory letter through the unit commander or supervisor to any person who has acquired six traffic points within a six-month period.

16.3.4.2. Counseling or driver improvement interview by the unit commander of any person who acquires more than 6 points but less than 12 traffic points within a six-month period.

16.3.4.3. Referral for medical evaluation when a driver, based on a reasonable belief, appears to have mental or physical limits that had or may have an adverse effect on driving ability.

16.3.4.4. Attendance at a Driver Improvement Program (DIP) to improve driving skill, awareness, or attitude.

16.3.6. The Installation Commander may suspend, or revoke privileges as provided by this program regardless of whether these improvement measures are accomplished.

16.3.5. After coordination with the SJA, unit commanders will, for members deemed to be in military status, direct drug and/or alcohol testing within 24 hours of suspected alcohol related motor vehicle/traffic incidents or misconduct, episodes of aberrant or bizarre behavior or where there is reasonable suspicion of drug use and the member refuses to provide consent for testing. Commanders are also encouraged to ensure Blood Alcohol Tests (BAT) are taken as soon after the incident as possible to determine the level and intensity of alcohol involvement. For additional information refer to DAFI 31-218.

16.3.7. Notify in writing anyone whose driving privileges are suspended or revoked (for 1 violation or an accumulation of 12 traffic points within 12 consecutive months, or 18 traffic points within 24 consecutive months).

EDWARD J. SCHIERBERL III, Colonel, USAF  
Deputy Commander, 910th AW

**Attachment 1****GLOSSERY OF REFERENCES AND SUPPORTING INFORMATION*****References***

**AFPD 31-1**, *Integrated Defense*, 21 June 2018  
**AFMAN 31-116**, *Air Force Motor Vehicle Traffic Supervision*, 18 December 2015  
**AFMAN 32-1017**, *DoD Transportation Engineering Program*, 17 November 2003  
**DAFI 31-145**, *Antiterrorism (AT)*, 14 November 2022  
**DAFI 31-101**, *Integrated Defense*, 25 March 2020  
**DAFI 31-118**, *Security Forces Systems and Administration*, 15 November 2023  
**DAFI 31-218(I)**, *Motor Vehicle Traffic Supervision (Interservice)*, 22 May 2006  
**AFI 33-322**, *Records Management and Information Governance Program*, 28 July 2021  
**AFI 44-102**, *Medical Care Management*, 17 March 2015  
**AFI 44-121**, *Alcohol and Drug Abuse Prevention and Treatment (ADAPT) Program*, 18 July 2018  
**DAFI 91-207**, *The Traffic Safety Program*, 26 July 2019

***Adopted Forms***

**AF Form 75**, *Visitor/Vehicle Pass*  
**AF Form 1315**, *Accident Report*  
**AF Form 2293**, *US Air Force Motor Vehicle Operator Identification Card*  
**AF Form 3545**, *Incident Report*  
**CVB Form 1805**, *United States District Court Violation Notice*  
**DD Form 1920**, *Alcohol Influence Report*  
**DD Form 2507**, *Notice of Vehicle Impoundment*  
**DD Form 1408**, *Armed Forces Traffic Ticket*  
**DD Form 1920**, *Alcohol Influence Report*

***Abbreviations and Acronyms***

**AFJIS**—Air Force Justice Information System  
**AFOSI**—Air Force Office of Special Investigation  
**ATV**—All Terrain Vehicle  
**BCE**—Base Civil Engineer  
**DFC**—Defense Force Commander  
**DBIDS**—Defense Biometric Identification System  
**DoD**—Department of Defense  
**DoDD**—Department of Defense Directive  
**ECC**—Emergency Control Center  
**ESOH**—Environmental Safety and Occupational Health  
**FPCON**—Force Protection Condition  
**GOV**—Government Owned Vehicle  
**GORV**—Government Off Road Vehicle  
**IACP**—Installation Access Control Point

**MSF**—Motorcycle Safety Foundation

**MSG**—Mission Support Group

**POV**—Privately Owned Vehicle

**PPE**—Personal Protective Equipment

**SJA**—Staff Judge Advocate

**S5P**—910th Security Forces Police Services

**UCMJ** – Uniform Code of Military Justice

**Attachment 2  
Deployed/TDY Parking Permit  
(Part 1)**

<b>TDY PARKING PERMIT</b>			
<b>NAME</b>	<b>UNIT</b>	<b>DEPLOYMENT START</b>	<b>DEPLOYMENT END</b>
<b>EMERGENCY CONTACT</b>		<b>PHONE #</b>	
			
<b>VEHICLE KEYS WITH</b>			
<b>CAR MAKE/MODEL</b>	<b>LICENSE PLATE #</b>	<b>VIN #</b>	

**Attachment 3**  
**Deployed/TDY Parking Permit**  
(Part 2)

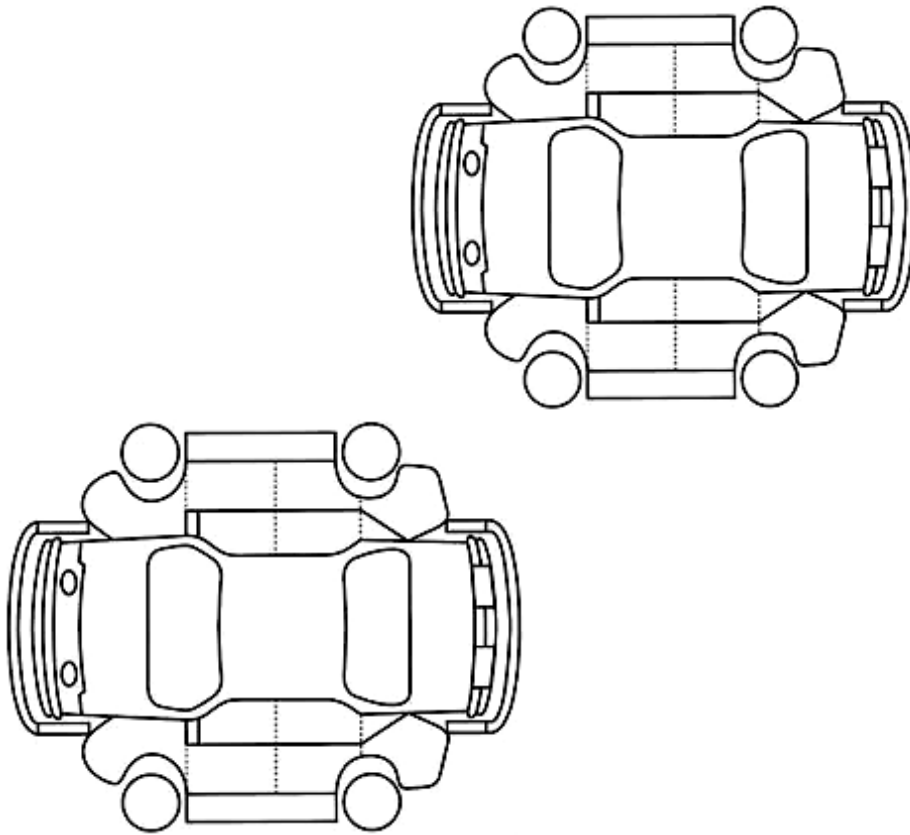

PRE-DEPLOYMENT CAR DAMAGE INSPECTION POST-DEPLOYMENT CAR DAMAGE INSPECTION

Inspectors signature/date: \_\_\_\_\_

Inspectors signature/date: \_\_\_\_\_

Owner Signature/date: \_\_\_\_\_

Owners Signature/date: \_\_\_\_\_

**Attachment 4  
Deployed/TDY Parking Permit  
(Part 3)**

# TDY PARKING PERMIT



**Place inside vehicle on dashboard. When back from TDY drop off pass with gate guard.**

---

